



Manufactured by:
Backyard Discovery
3305 Airport Drive, Pittsburg, KS
66762 800-856-4445

Basepoint Business Centre: Rivermead Drive, Westlea, Swindon SN5 7EX Phone: 0800-118-2476
J.P. Coenstraat 7, The Bridge, The Hague, 2595 WP, Netherlands Phone: 08005678990

ZALIE GREENHOUSE

MODEL # : 2304123

For Horticulture Use Only



Please visit www.backyarddiscovery.com

For the most up to date assembly manual, to register your product, or to order replacement parts *Para obtener instrucciones en español, visite* www.backyarddiscovery.com



EASY STEP-BY-STEP
3D INTERACTIVE INSTRUCTIONS
DOWNLOAD THE FREE APP



OWNER'S MANUAL - BASIC SETUP DIMENSIONS & ASSEMBLY NOTES

It is critically important that you start with square and level footings or concrete pad to attach your structure

- Pay close attention to the items needed for each step. Make sure you are using the correct hardware for each step. Using incorrect hardware may result in improper assembly
- Remember to double check for underground utilities and overhead electrical lines
- The hardware to attach the mounts to the ground is included.
- The hardware to mount the structure permanently to a concrete surface is not included.

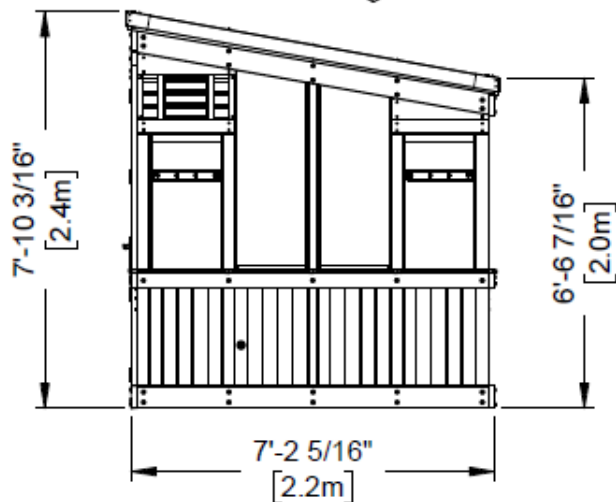
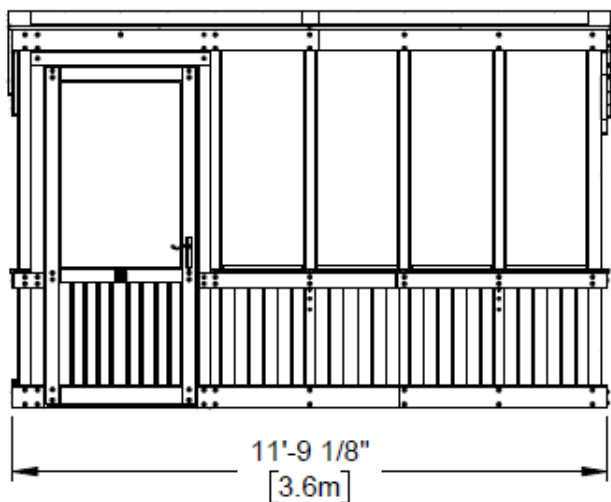
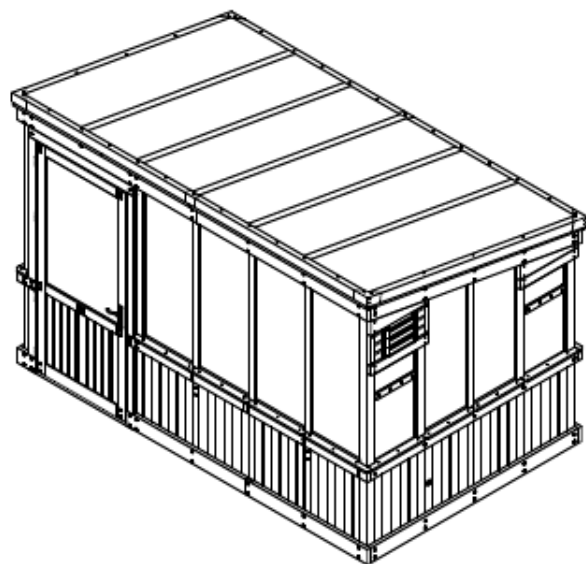
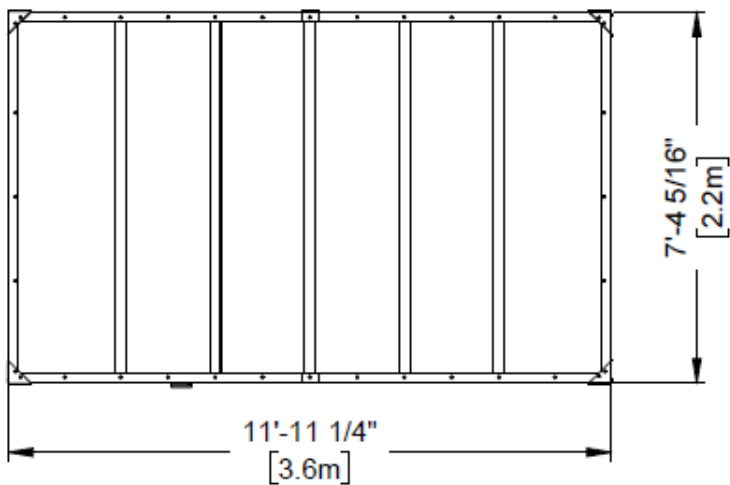

Bellerose Greenhouse

Site Location and Preparation

- A. Check your local building and city codes for permit requirements or restrictions, including any HOA restrictions.
- B. Select a location with lots of sun, good drainage, and the ability to create a level firm surface for your greenhouse.
 - A firm, level surface is critically important to the longevity of your greenhouse.
 - Ensure it is accessible on all sides to clean and conduct annual maintenance
 - Consider a site location with a close proximity to both water and electrical sources
 - Make sure site drains well and avoid low lying areas.
- C. Before preparing your surface – double check for possibility of any underground utilities (example: gas, cable, or sprinkler lines)
 - Remove any grass, dirt, landscaping to create a level, hard-packed surface
 - This may involve some digging to create a level spot, dependent on your site location.
- D. Determine your preferred site pad materials for your greenhouse
 - It is NOT recommended to set the greenhouse directly on soil or grass. This will shorten the lifespan of your greenhouse.
 - Site pad options include gravel, patio or brick pavers, concrete pad.
 - If building on a natural surface, such as gravel, see step 103.
 - If building on a concrete foundation see Step 104.

PRE-ASSEMBLY STEP 1 - SORTING PARTS

It is critical for ease of assembly that you take the time to sort and organize the wood and hardware.

WOOD PARTS:

- Organize wood parts by the three-digit, alpha-numeric number stamped on each board (ex. P01).
- If there are multiple boards with the same stamped number, stack those pieces together.
- Stamps can be found on the flat surface of the boards or on the end of the boards.
- Allow yourself plenty of room - the wood pieces can take up a significant amount of space.

NOTE: CARTONS ARE NOT ORGANIZED BY BOARD NUMBER.



HARDWARE PARTS:

- We recommend that you have a separate table to organize the hardware.
- Hardware bags are printed with a seven-digit, alpha-numeric part number.
- You can organize your hardware by part number or group by hardware type (i.e. bolts, nuts, etc.).
- During assembly you only need to reference the last four digits of the number.

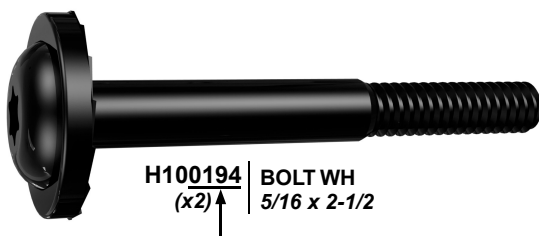

PRE-ASSEMBLY STEP 2 - TOOLS REQUIRED



Cordless Drill
or Electric Drill



Drill
Attachments:
Phillips Head



1/8", 3/16", 3/8" &
7/16" Drill Bits



Phillips Screw Driver

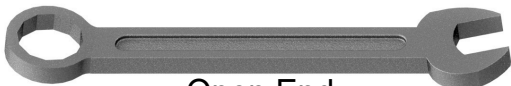

Open End
Wrenches 1/2" &
9/16"



3/8" Drive Ratchet, 1/2" &
7/16" STD Sockets 1/2" & 7/16"
Deep Sockets



Claw Hammer

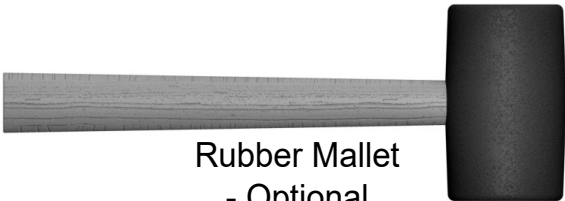

Rubber Mallet
- Optional

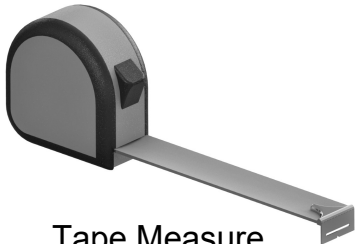

Tape Measure

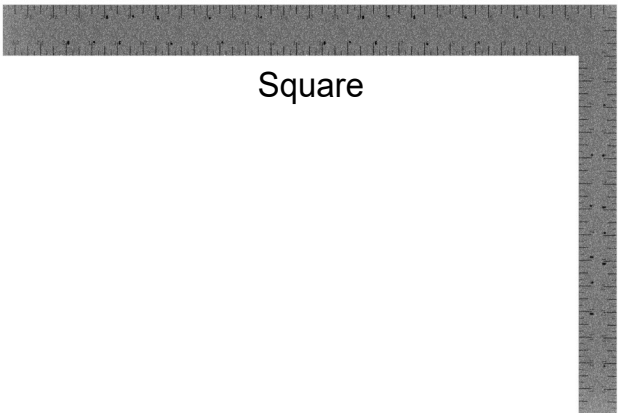

Square



Level 24"

PRE-ASSEMBLY STEP 3 - CHOOSE YOUR ASSEMBLY METHOD

There are several types of assembly instructions available to you.

1. Printed Assembly Manual included with your set
2. BILT APP - 3D interactive instructions
3. Combination of the Printed Manual and BILT APP (Note: Step numbers can differ between the two methods)



BILT.

Scan for easy
3D instructions

Download the BILT app
before you begin

Download on the
App Store

GET IT ON
Google Play

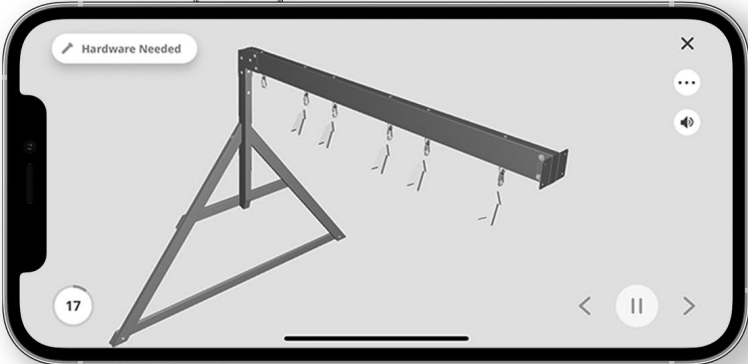

Hardware Needed

17

< || >

The image shows a smartphone screen displaying a 3D assembly instruction. The screen features a 3D model of a metal frame structure. At the top left, there is a button labeled 'Hardware Needed'. At the bottom left, the step number '17' is displayed. At the bottom right, there are navigation controls including a back arrow, a pause button, and a forward arrow. The entire advertisement is enclosed in a grey border.

OWNER'S MANUAL - PARTS IDENTIFICATION

WOOD COMPONENTS (NOT TO SCALE)



B01 POST - W4L18676
(x1) 3"x3"x89 5/16" (76x76x2269)

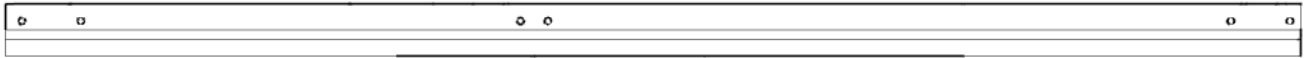

B02 POST - W4L18677
(x1) 3"x3"x74 3/8" (76x76x1889)



B03 POST - W4L18678
(x1) 3"x3"x74 3/8" (76x76x1889)



B04 POST - W4L18679
(x1) 3"x3"x89 5/16" (76x76x2269)



B05 VERTICAL UPRIGHT - W4L18686
(x1) 3"x3"x85 3/4" (76x76x2178)



B06 VERTICAL UPRIGHT - W4L18687
(x1) 3"x3"x78 3/4" (76x76x2000)



B07 POST - W4L18707
(x1) 3"x3"x89 5/16" (76x76x2269)



B08 POST - W4L18710
(x1) 3"x3"x89 5/16" (76x76x2269)



D01 BASE BOARD - W4L18684
(x1) 1 7/16"x5 1/4"x71 3/4" (36x134x1822)



D02 BASE BOARD - W4L18685
(x2) 1 7/16"x5 1/4"x83 7/16" (36x134x2119)



D03 HEADER - W4L18697
(x2) 1 7/16"x5 1/4"x23 1/4" (36x134x591)



D04 BASE BOARD - W4L18705
(x1) 1 7/16"x5 1/4"x49 5/16" (36x134x1252)



D05 BASE BOARD - W4L18706
(x1) 1 7/16"x5 1/4"x50 1/4" (36x134x1276)



D06 BASE BOARD - W4L18713
(x1) 1 7/16"x5 1/4"x7 3/8" (36x134x188)



D07 BASE BOARD - W4L18730
(x1) 1 7/16"x5 1/4"x71 3/4" (36x134x1822)

OWNER'S MANUAL - PARTS IDENTIFICATION

WOOD COMPONENTS (NOT TO SCALE)



E01 LEDGE BOARD - W4L18693
(x6) 1 7/16"x3 3/8"x22 7/16" (36x86x570)



E02 LEDGE BOARD - W4L18694
(x2) 1 7/16"x3 3/8"x19 15/16" (36x86x507)



E03 LEDGE BOARD - W4L18695
(x1) 1 7/16"x3 3/8"x19 15/16" (36x86x507)



E04 LEDGE BOARD - W4L18696
(x1) 1 7/16"x3 3/8"x19 15/16" (36x86x507)



E05 WINDOW TRIM - W4L18698
(x2) 1 7/16"x3 3/8"x23 1/4" (36x86x591)



E06 RUNNING BOARD - W4L18702
(x1) 1 7/16"x3 3/8"x72 1/2" (36x86x1842)



E07 RUNNING BOARD - W4L18703
(x1) 1 7/16"x3 3/8"x83 7/16" (36x86x2119)



E08 RUNNING BOARD - W4L18708
(x1) 1 7/16"x3 3/8"x50 1/16" (36x86x1272)



E09 RUNNING BOARD - W4L18709
(x1) 1 7/16"x3 3/8"x51" (36x86x1296)



E10 DOOR TRIM - W4L18711
(x1) 1 7/16"x3 3/8"x42 1/2" (36x86x1080)



E11 RUNNING BOARD - W4L18712
(x1) 1 7/16"x3 3/8"x7 3/8" (36x86x188)



E12 LEDGE BOARD - W4L18718
(x1) 1 7/16"x3 3/8"x26 1/4" (36x86x666)



E13 LEDGE BOARD - W4L18719
(x1) 15/16"x2 15/16"x21 3/4" (24x74x553)



E14 LEDGE BOARD - W4L18720
(x1) 15/16"x2 15/16"x21 3/4" (24x74x553)

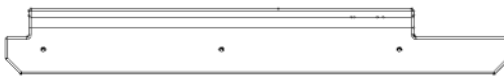

E15 LEDGE BOARD - W4L18721
(x1) 1 7/16"x3 3/8"x26 1/4" (36x86x666)



E16 LEDGE BOARD - W4L18722
(x1) 1 7/16"x3 3/8"x23 5/8" (36x86x600)



E17 LEDGE BOARD - W4L18723
(x1) 1 7/16"x3 3/8"x21 3/4" (36x86x553)



E18 LEDGE BOARD - W4L18724
(x1) 1 7/16"x3 3/8"x21 3/4" (36x86x552)



E19 LEDGE BOARD - W4L18725
(x1) 1 7/16"x3 3/8"x26 1/4" (36x86x666)



E20 RUNNING BOARD - W4L18731
(x1) 1 7/16"x3 3/8"x72 1/2" (36x86x1842)

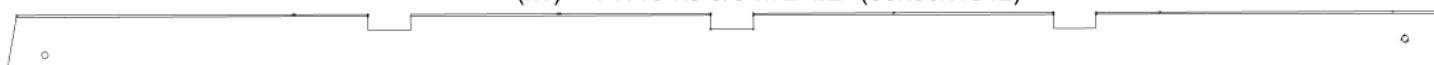

E21 RAFTER - W4L18736
(x4) 1 7/16"x3 3/8"x85 1/4" (36x86x2165)

OWNER'S MANUAL - PARTS IDENTIFICATION

WOOD COMPONENTS (NOT TO SCALE)

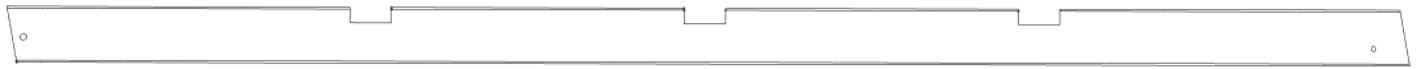

E22 RAFTER - W4L18740
(x1) 1 7/16"x3 3/8"x85 1/4" (36x86x2165)



E27 RUNNING BOARD - W4L18700
(x1) 1 7/16"x3 3/8"x83 7/16" (36x86x2119)



F01 VERTICAL UPRIGHT - W4L18680
(x4) 1 7/16"2 3/8"x74 3/8" (36x60x1889)



F02 VERTICAL UPRIGHT - W4L18681
(x1) 1 7/16"x2 3/8"x78 3/4" (36x60x2000)



F03 VERTICAL UPRIGHT - W4L18682
(x1) 1 7/16"x2 3/8"x82 1/4" (36x60x2089)



F04 VERTICAL UPRIGHT - W4L18683
(x1) 1 7/16"x2 3/8"x85 13/16" (36x60x2179)



F05 VERTICAL UPRIGHT - W4L18704
(x2) 1 7/16"2 3/8"x89 5/16" (36x60x2269)



F06 VERTICAL UPRIGHT - W4L18726
(x1) 1 7/16"2 3/8"x82 1/4" (36x60x2089)



F07 WINDOW LATCH BOARD - W4L18741 (x2) 1 7/16"x1 9/16"x17 1/4" (36x40x438) F08 TABLE FRAME BOARD - W4L18748 (x4) 1 7/16"x1 7/16"x13 1/8" (36x36x333) F09 DIAGONAL BRACE - W4L18749 (x8) 1 7/16"x2 3/8"x15 3/16" (36x60x385)



F10 VERTICAL UPRIGHT - W4L18674
(x1) 1 7/16"2 3/8"x89 5/16" (36x60x2269)



F11 VERTICAL UPRIGHT - W4L18675
(x1) 1 7/16"2 3/8"x74 3/8" (36x60x1889)



F12 VERTICAL UPRIGHT - W4L18699
(x1) 1 7/16"x2 3/8"x89 5/16" (36x60x2269)



F13 DOOR TRIM - W4L18727
(x1) 1 7/16"x1 7/16"x36 9/16" (36x60x928)



H01 FASCIA - W4L18671
(x4) 15/16"X3 3/8"X71 9/16" (24x86x1817)

















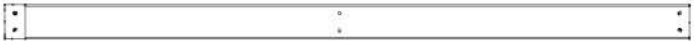









H03 FASCIA - W4L18673
(x2) 15/16"x3 3/8"x88 3/16" (24x86x2240)

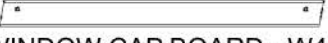
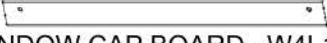

J07 PURLIN - W4L18738
(x2) 15/16"x2 3/8"x69 13/16" (24x60x1773)

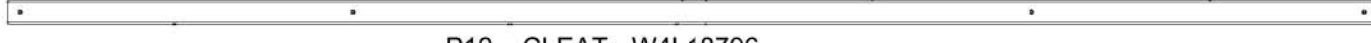
OWNER'S MANUAL - PARTS IDENTIFICATION

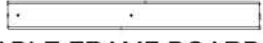
WOOD COMPONENTS (NOT TO SCALE)

- 
- J08 WINDOW HANDLE - W4L18810
(x4) 15/16"x2 3/8"x15 1/2" (24x60x394)
- 
- J10 WINDOW CAP BOARD - W4L18813
(x4) 15/16"x2 3/8"x16 9/16" (24x60x413)
- 
- J11 LOUVER TRIM - W4L18814
(x4) 15/16"x2 3/8"x17 1/2" (24x60x445)
- 
- J12 LEDGE BOARD - W4L18816
(x1) 15/16"x1 15/16"x4 15/16" (24x50x126)
- 
- J13 PURLIN - W4L19106
(x4) 15/16"x2 3/8"x47 3/8" (24x60x1203)
- 
- J14 PURLIN - W4L19107
(x2) 15/16"x2 3/8"x46 5/16" (24x60x1176)
- 
- M05 TABLE TRIM - W4L18806
(x1) 5/8"x3 3/8"x80 7/16" (16x86x2043)
- 
- M06 TABLE TRIM - W4L18807
(x1) 5/8"x3 3/8"x41 1/2" (16x86x1054)
- 
- M07 TABLE TRIM - W4L18808
(x2) 5/8"x3 3/8"x60 1/16" (16x86x1526)
- 
- M08 TABLE TRIM - W4L18809
(x1) 5/8"x3 3/8"x39 1/2" (16x86x1004)
- 
- M09 TABLE TRIM - W4L18817
(x1) 5/8"x3 3/8"x16 5/8" (16x86x423)
- 
- N01 HANGER BOARD - W4L18737
(x10) 5/8"x2 3/8"x42 15/16" (16x60x1090)
- 
- N05 WINDOW STOP - W4L18811
(x2) 5/8"x2 3/8"x16 9/16" (16x60x420)
- 
- M10 MOUNT BOARD - W4L18820
(x1) 5/8"x3 3/8"x20 15/16" (16x86x532)
- 
- N06 TABLE TRIM - W4L18818
(x1) 5/8"x16 5/8"x2 1/16" (16x52x423)
- 
- N07 HANGER BOARD - W4L18819
(x1) 5/8"x2 3/8"x80 7/16" (16x60x2043)
- 
- P02 DOOR TRIM - W4L18728
(x2) 15/16"x1 7/16"x79 15/16" (24x36x2030)
- 
- P03 WINDOW CAP BOARD - W4L18732
(x10) 1 7/16"x1 7/16"x19 7/8" (36x36x505)
- 
- P05 WINDOW CAP BOARD - W4L18734
(x2) 1 7/16"x1 7/16"x17 9/16" (36x36x446)
- 
- P06 WINDOW CAP BOARD - W4L18735
(x4) 1 7/16"x1 7/16"x17 7/8" (36x36x454)
- 
- P07 CLEAT - W4L18739
(x2) 1 7/16"x1 7/16"x76 3/4" (36x36x1950)
- 
- P12 CLEAT - W4L18796
(x1) 1 7/16"x1 7/16"x80 7/16" (36x36x2043)
- 
- P13 CLEAT - W4L18797
(x1) 1 7/16"x1 7/16"x39 15/16" (36x36x1014)
- 
- P16 TABLE FRAME BOARD - W4L18804
(x8) 1 7/16"x1 7/16"x13 1/8" (36x36x333)
- 
- Q01 WALL BOARD - W4L18688
(x50) 15/16"x4"x32 1/16" (24x98x814)
- 
- Q02 WALL BOARD - W4L18689
(x10) 15/16"x3 15/16"x32 1/16" (24x100x814)

OWNER'S MANUAL - PARTS IDENTIFICATION

WOOD COMPONENTS (NOT TO SCALE)



Q03 WALL BOARD - W4L18690
(x21) 15/16"x4 1/16"x32 1/16" (24x103x814)



Q05 WALL BOARD - W4L18692
(x1) 15/16"x3 3/4"x32 1/16" (24x95x814)



Q07 WALL BOARD - W4L18715
(x6) 15/16"x4 1/16"x9 3/16" (24x103x234)



Q09 WALL BOARD - W4L18717
(x2) 15/16"x4 1/16"x32 1/16" (24x103x814)



Q12 WALL BOARD - W4L18672
(x1) 15/16"x4 1/16"x32 1/16" (24x103x814)



Q14 WALL BOARD - W4L18733
(x2) 15/16"x3 7/16"x32 1/16" (24x87x814)



Q04 WALL BOARD - W4L18691
(x2) 15/16"x4 1/16"x32 1/16" (24x103x814)

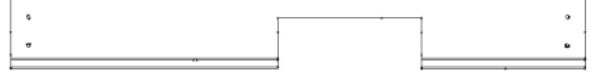

Q06 WALL BOARD - W4L18714
(x2) 15/16"x4 1/16"x32 1/16" (24x103x814)



Q08 WALL BOARD - W4L18716
(x6) 15/16"x4 1/16"x14 13/16" (24x103x377)



Q11 WALL BOARD - W4L18800
(x1) 15/16"x3 3/4"x32 1/16" (24x95x814)



Q13 WALL BOARD - W4L18701
(x2) 15/16"x3 7/16"x32 1/16" (24x87x814)



S01 LOUVER TRIM - W4L18815
(x4) 15/16"x15/16"x7 15/16" (24x24x202)

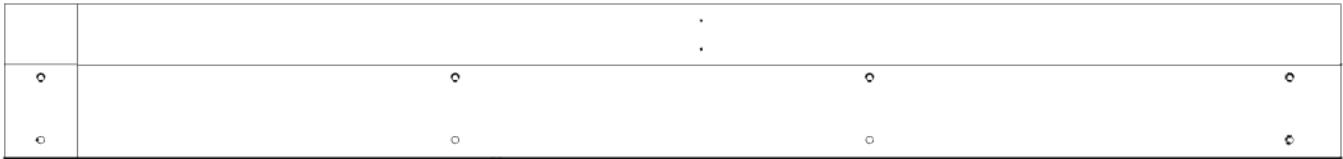

J01 HEADER - W2A03980
(x1) 1 7/16"x8 7/16"x72 1/2" (36x214x1842)



J02 HEADER - W2A03981
(x1) 1 7/16"x8 7/16"x72 1/2" (36x214x1842)

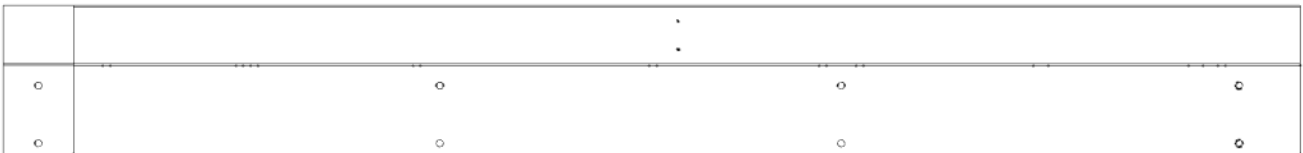

J03 HEADER - W2A03982
(x1) 1 7/16"x8 7/16"x72 1/2" (36x214x1842)

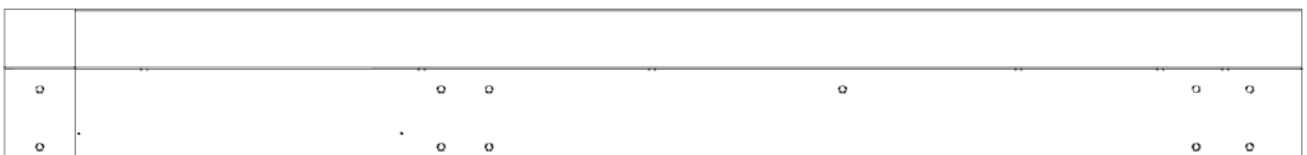

J04 HEADER - W2A03983
(x1) 1 7/16"x8 7/16"x72 1/2" (36x214x1842)

OWNER'S MANUAL - PARTS IDENTIFICATION

WOOD COMPONENTS (NOT TO SCALE)

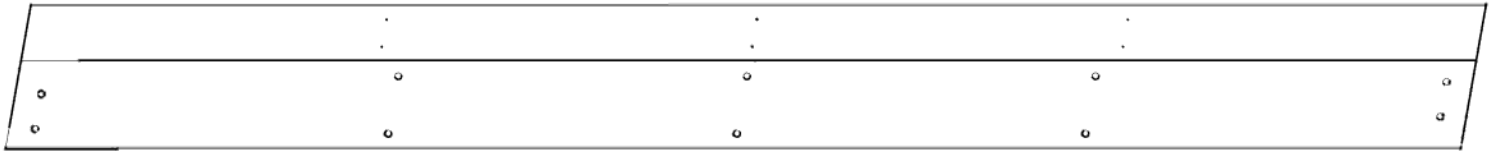

J05 HEADER - W2A03984
(x1) 1 7/16"x8 7/16"x86 1/4" (36x214x2190)

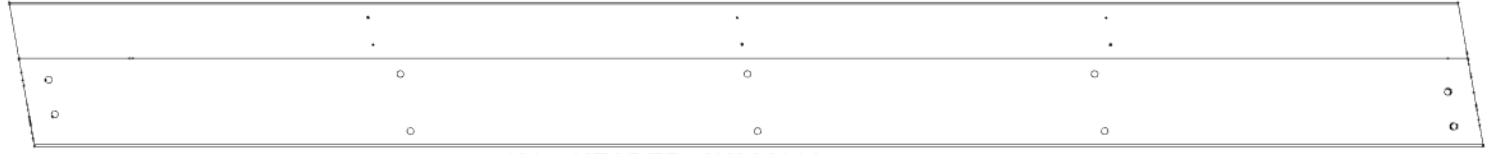

J06 HEADER - W2A03985
(x1) 1 7/16"x8 7/16"x86 1/4" (36x214x2190)

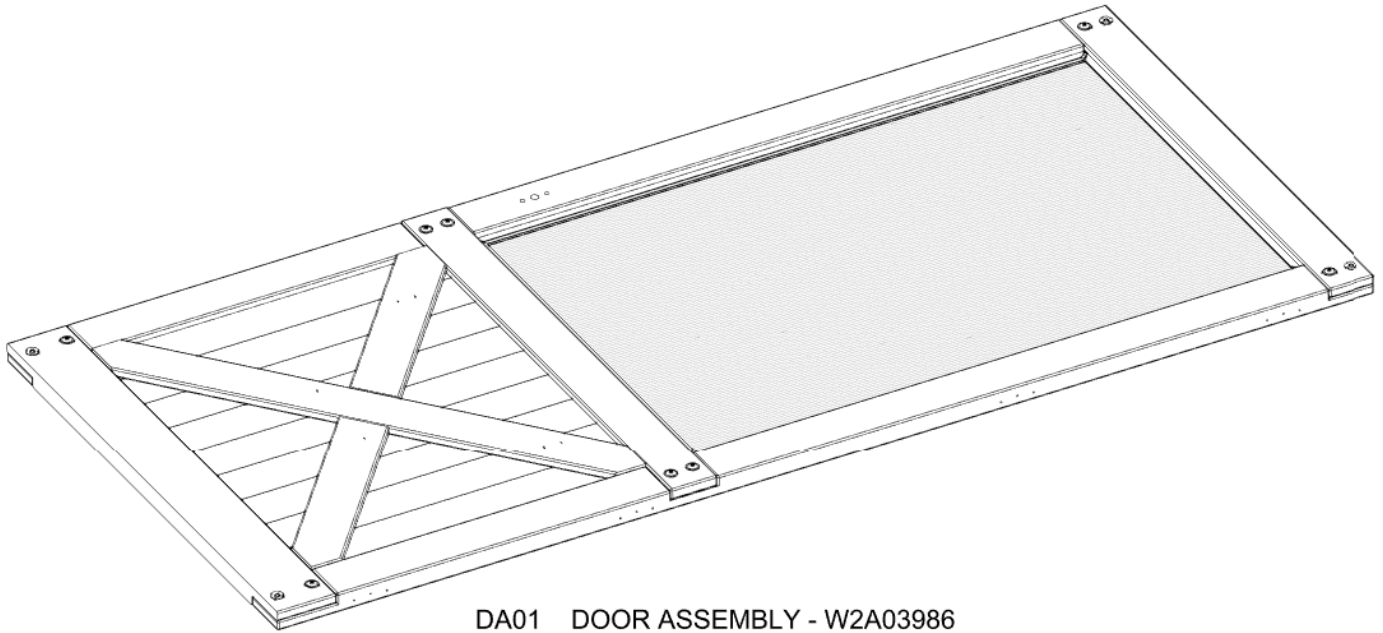

DA01 DOOR ASSEMBLY - W2A03986
(x1) 1 7/8"x35 13/16"x80" (48x910x2032)

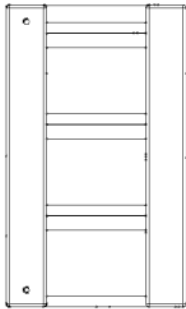

FT01 FAN TRIM ASSEMBLY - W2A03987
(x1) 1 7/16"x6 5/16"x10 9/16" (36x160x112)

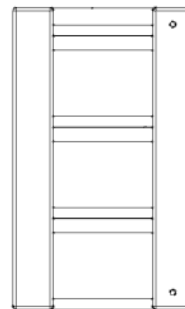

FT02 FAN TRIM ASSEMBLY - W2A03988
(x1) 1 7/16"x6 5/16"x10 9/16" (36x160x112)

OWNER'S MANUAL - PARTS IDENTIFICATION

WOOD COMPONENTS (NOT TO SCALE)

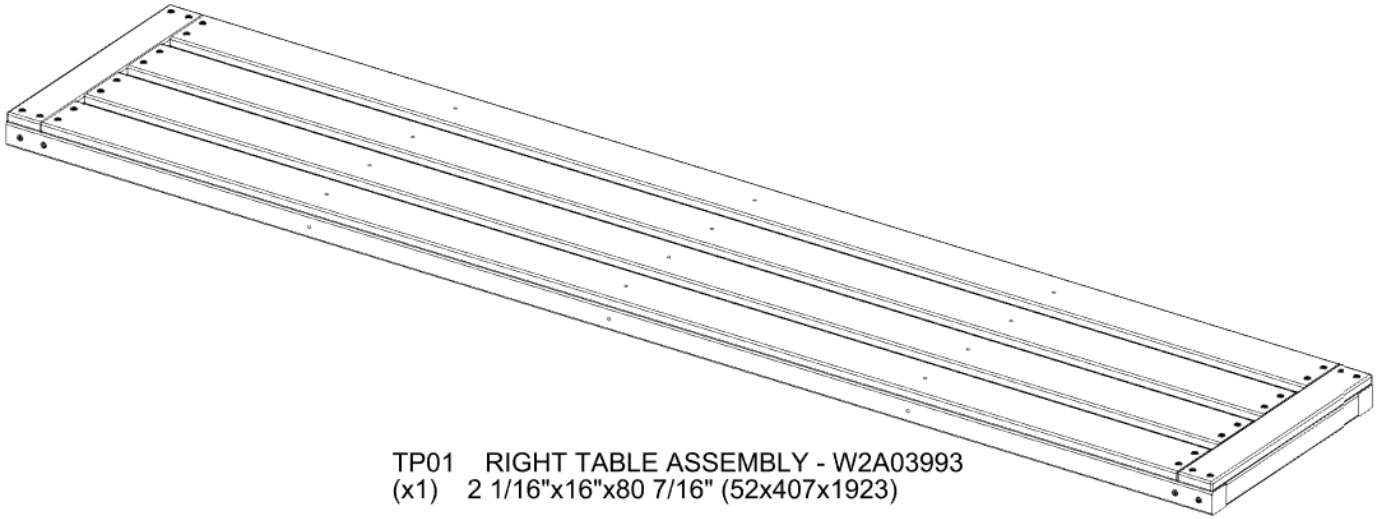

TP01 RIGHT TABLE ASSEMBLY - W2A03993
(x1) 2 1/16"x16"x80 7/16" (52x407x1923)

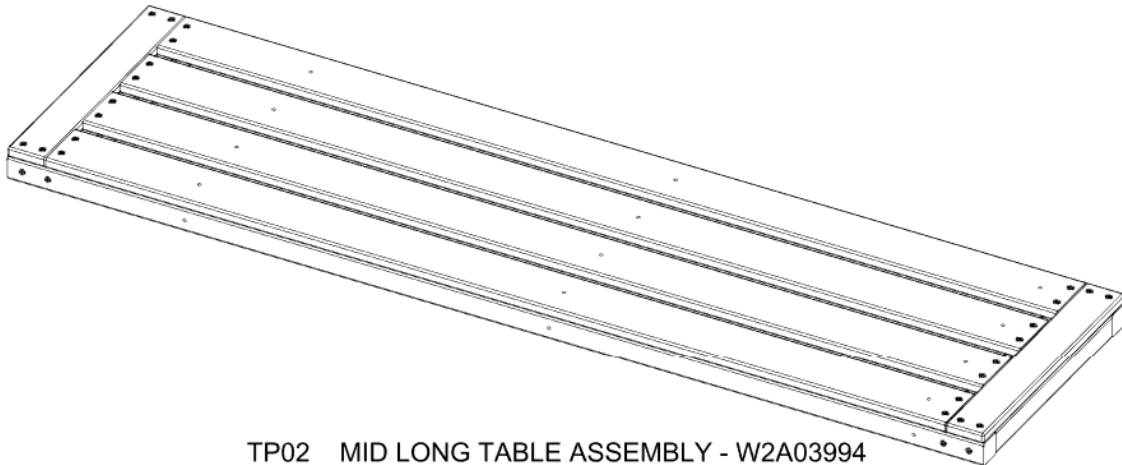

TP02 MID LONG TABLE ASSEMBLY - W2A03994
(x2) 2 1/16"x16"x60 1/16" (52x407x1406)

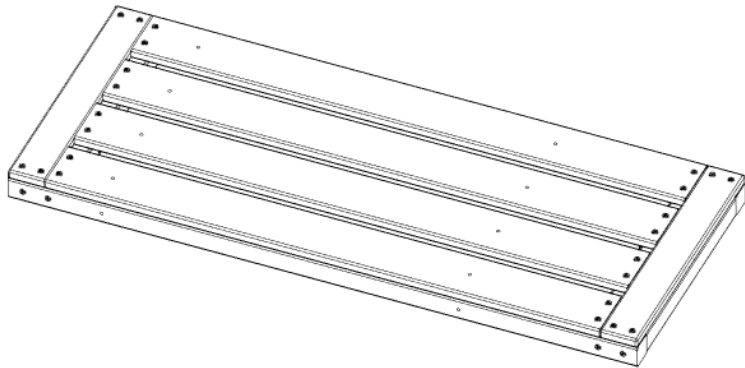

TP03 MID SHORT TABLE ASSEMBLY - W2A03995
(x1) 2 1/16"x16"x39 1/2" (52x407x884)

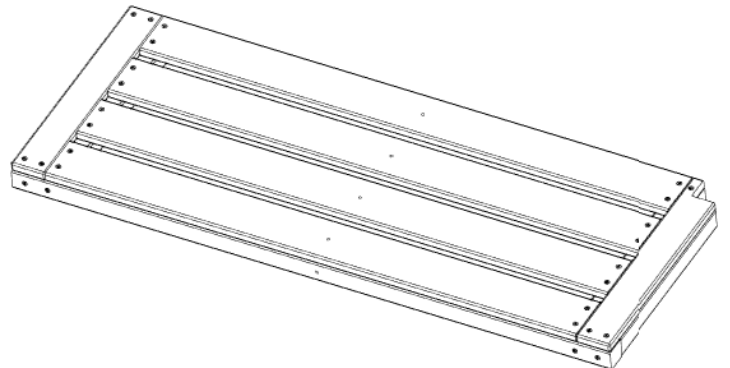

TP04 LEFT TABLE ASSEMBLY - W2A03996
(x1) 2 1/16"x16"x41 1/2" (52x407x934)

OWNER'S MANUAL - PARTS IDENTIFICATION

ACCESSORY COMPONENTS (NOT TO SCALE)



A6P00754 THERMOSTAT
(x1)

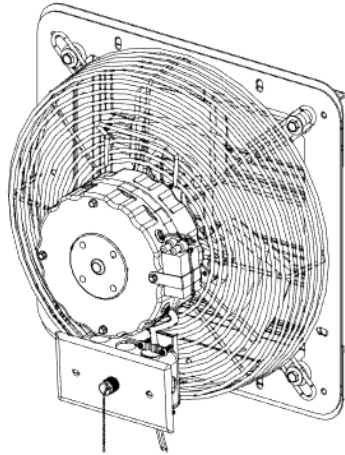

A4M02383 EXHAUST FAN
(x1)



9205413 ELECTRICAL ENCLOSURE
(x1)



A6P00692 CORD GROMMET
(x1)



A4M02158 BYD ID TAG
(x1)

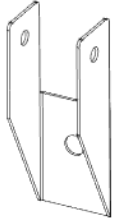

A4M02093 RAFTER BRACKET
(x10)

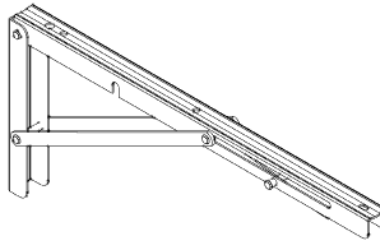

A4M02094 FOLDING TABLE BRACKET
(x6)

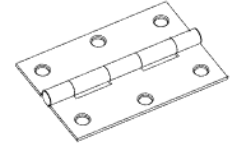

A4M00557 HINGE ASSEMBLY
(x4)

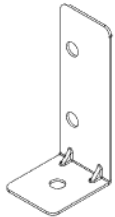

A4M02502 ANCHOR BRACKET
(x1)

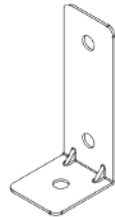

A4M02096 ANCHOR BRACKET
(x2)

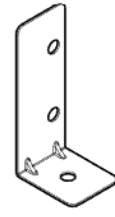

A4M02503 ANCHOR BRACKET
(x2)

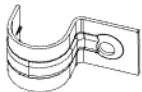

A4M02385 PIPE CLAMP
(x2)



A4M02091 GROUND STAKE
(x5)

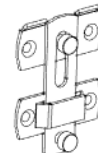

A4M02607 WINDOW LATCH
(x2)

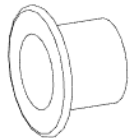

A6P00577 RUBBER GROMMET
(x1)

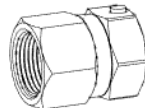

A6P00648 THREADED HOSE FITTING
(x1)

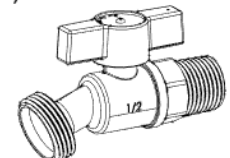

A4M02384 HOSE FAUCET
(x1)

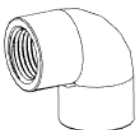

A6P00646 ELBOW 1/2" NPT
(x2)



A6P00645 PIPE 1/2" SCH40 X 24"
(x1)

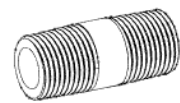

A6P00649 THREADED PIPE CONNECTOR
(x1)

OWNER'S MANUAL - PARTS IDENTIFICATION

ACCESSORY COMPONENTS (NOT TO SCALE)

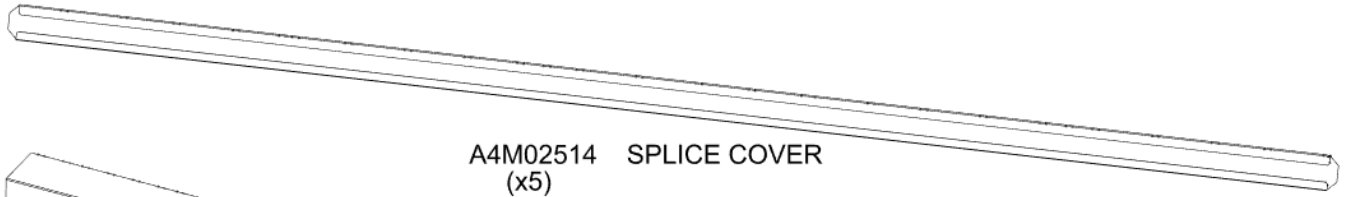

A4M02514 SPLICE COVER
(x5)

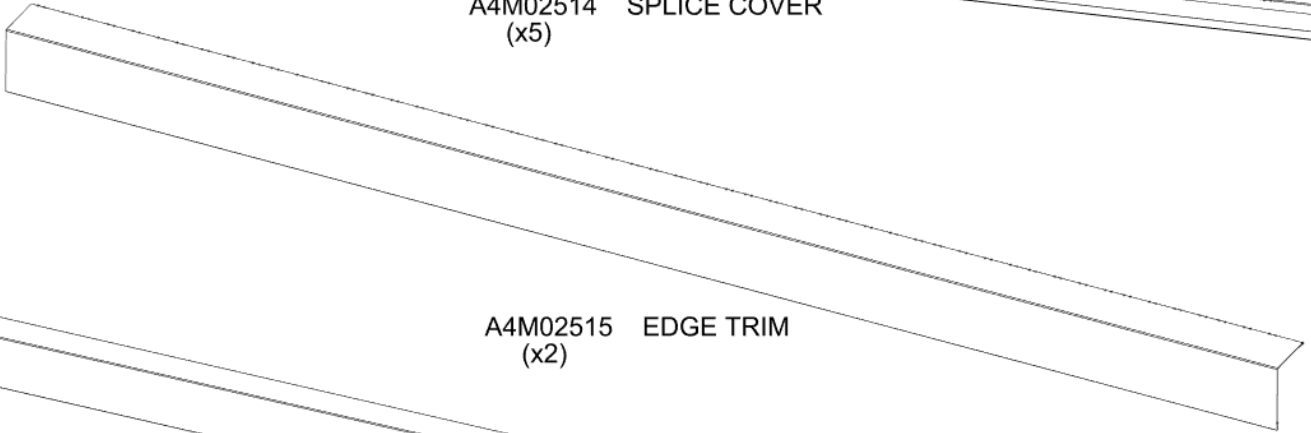

A4M02515 EDGE TRIM
(x2)

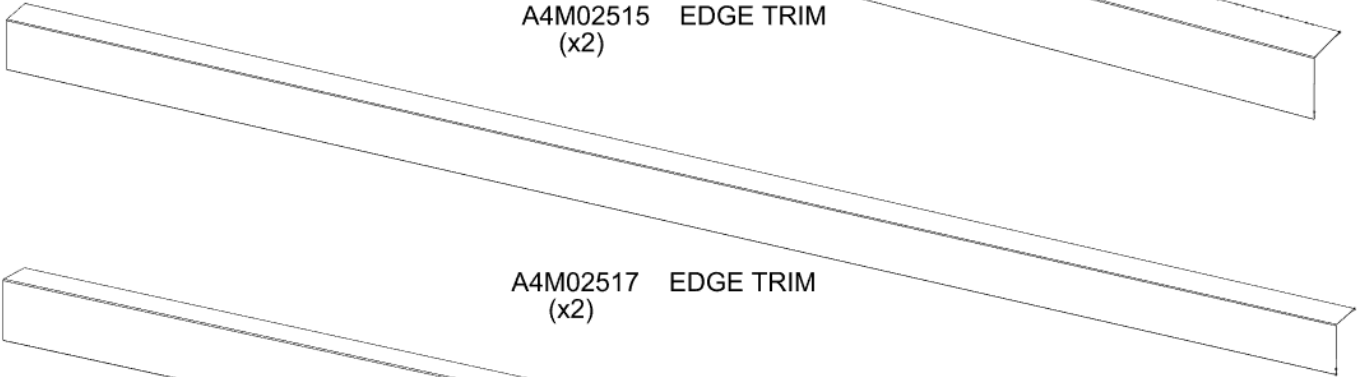

A4M02517 EDGE TRIM
(x2)

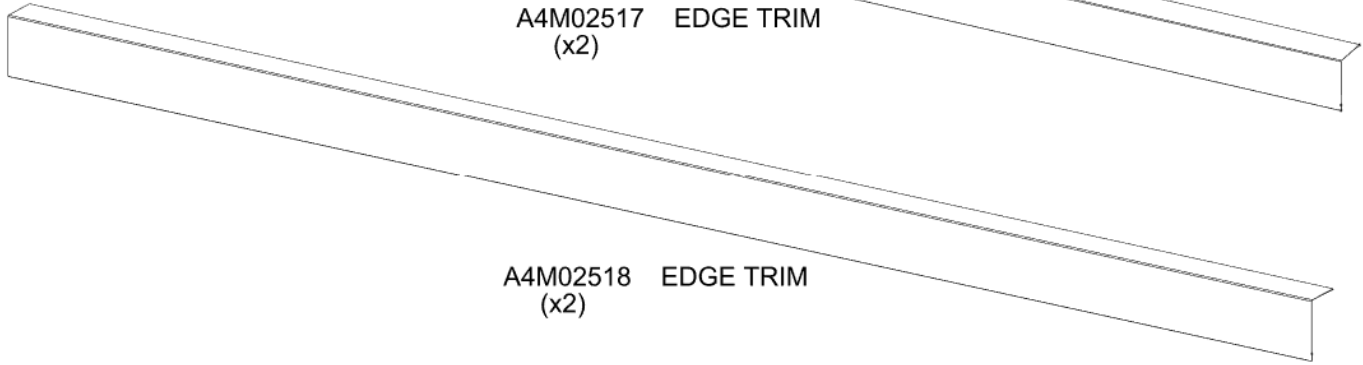

A4M02518 EDGE TRIM
(x2)

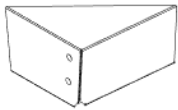

A4M02525 CORNER SPLICE TRIM LH
(x1)

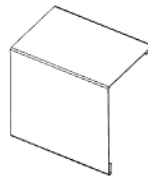

A4M02516 EDGE TRIM SPLICE
(x1)

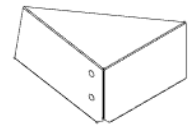

A4M02524 CORNER SPLICE TRIM LH
(x1)

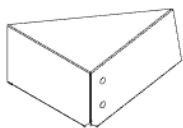

A4M02522 CORNER SPLICE TRIM RH
(x1)

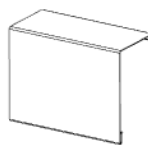

A4M02521 EDGE TRIM SPLICE
(x1)

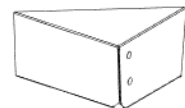

A4M02523 CORNER SPLICE TRIM RH
(x1)

OWNER'S MANUAL - PARTS IDENTIFICATION

ACCESSORY COMPONENTS (NOT TO SCALE)



A4M02411 DOOR PROTECTOR CHAIN
(x1)

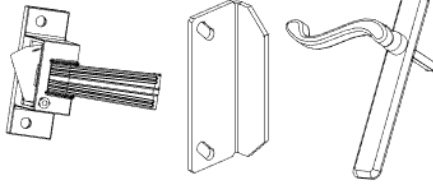

A4M02410 STORM DOOR HANDLE
(x1)

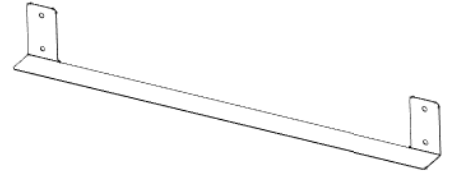

A4M02495 DOOR BRACKET
(x1)



A6P00813 DOUBLE SIDED TAPE
(x1)

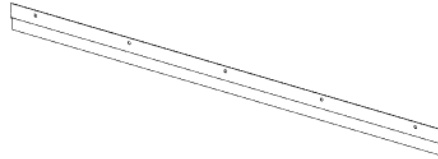

A6P00710 DOOR SWEEP
(x1)



A6P00690 DUST SEAL TAPE
(x2)



A6P00667 POLY CHANNEL
(x20)

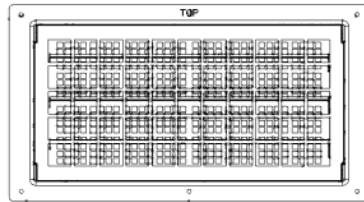

A6P00730 LOUVER
(x2)



A6P00668 POLY CHANNEL
(x8)

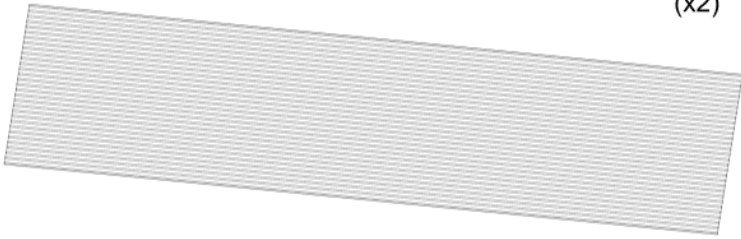

A6P00658 POLY ROOF SHEET
(x4)

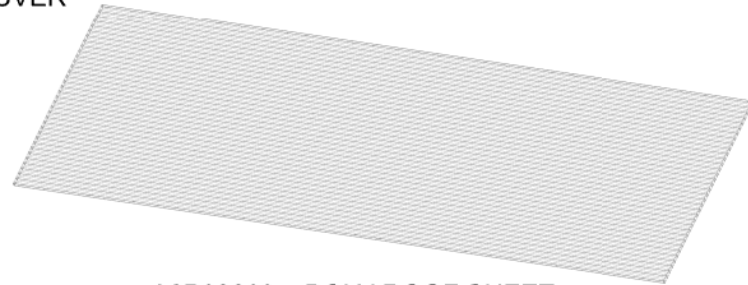

A6P00660 POLY ROOF SHEET
(x2)



A6P00659 POLY SHEET SPLICE
(x5)

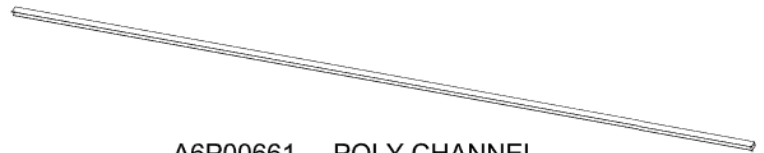

A6P00661 POLY CHANNEL
(x2)

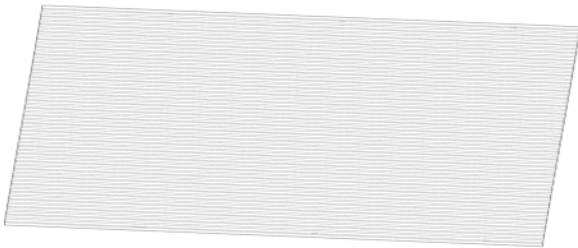

A6P00662 POLY WALL SHEET
(x6)

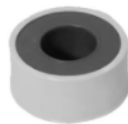

A6P00809 TEFLON TAPE ROLL
(x1)

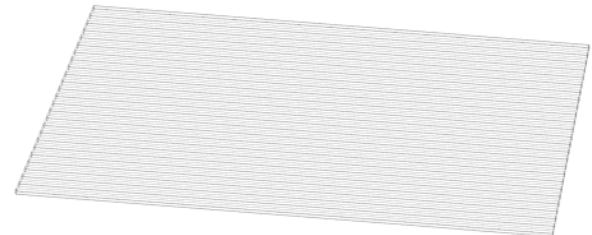

A6P00663 POLY WALL SHEET
(x1)

OWNER'S MANUAL - PARTS IDENTIFICATION

ACCESSORY COMPONENTS (NOT TO SCALE)

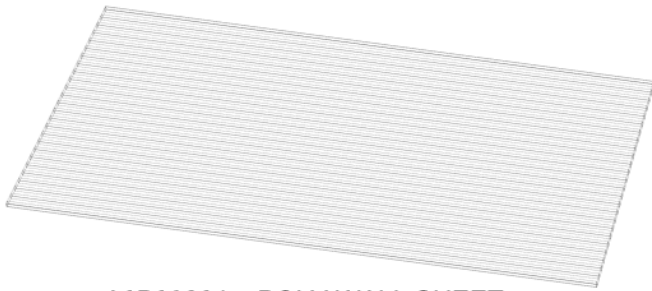

A6P00664 POLY WALL SHEET
(x1)

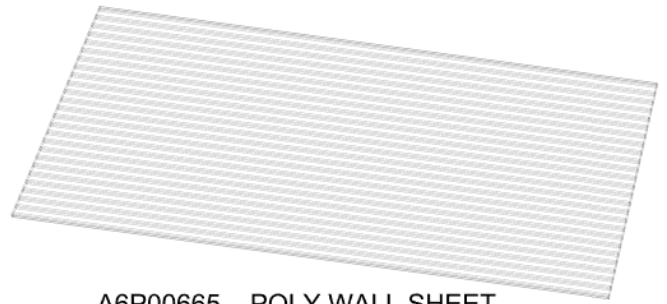

A6P00665 POLY WALL SHEET
(x1)



A6P00666 POLY WALL SHEET
(x1)

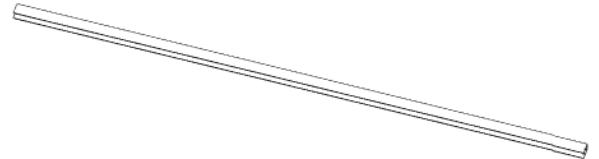

A6P00669 POLY CHANNEL WITH TAPE
(x12)



A6P00670 POLY CHANNEL WITH TAPE
(x1)



A6P00671 POLY CHANNEL WITH TAPE
(x3)



A6P00672 POLY CHANNEL WITH TAPE
(x4)



A6P00673 POLY CHANNEL WITH TAPE
(x3)



A6P00674 POLY CHANNEL WITH TAPE
(x1)



A6P00681 POLY CHANNEL WITH TAPE
(x8)

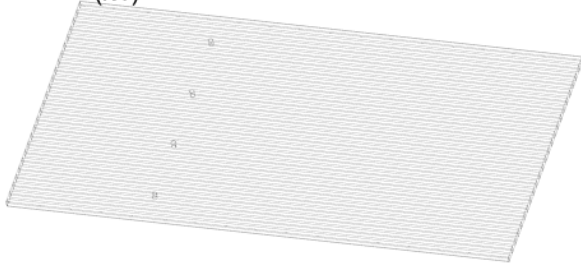

A6P00675 POLY WALL SHEET
(x2)

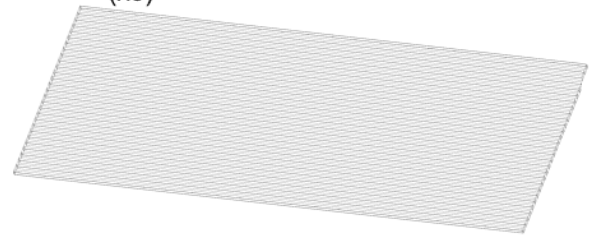

A6P00677 POLY WALL SHEET
(x4)

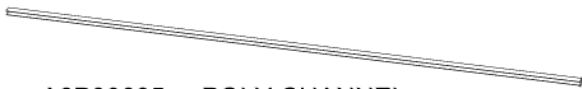

A6P00685 POLY CHANNEL
(x4)



A6P00709 POLY CHANNEL WITH TAPE
(x4)

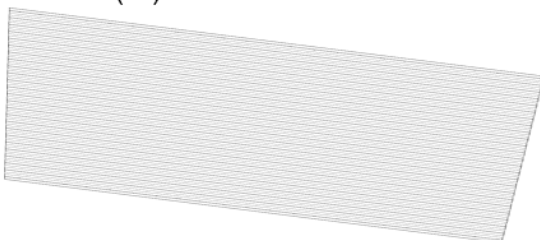

A6P00711 POLY WALL SHEET
(x1)



A6P00713 POLY CHANNEL
(x8)

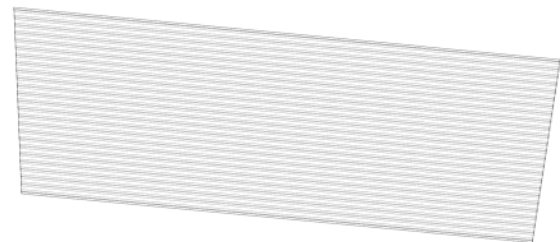

A6P00712 POLY WALL SHEET
(x1)

OWNER'S MANUAL - PARTS IDENTIFICATION

Hardware Components



H100513 | BOLT WH BLK
(x48) | 5/16x4-1/4

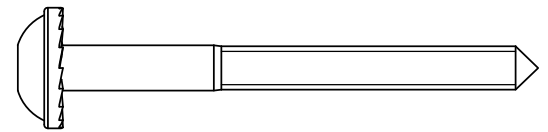

H100456 | LAG SCREW WH BLK
(x8) | 1/4x2-1/2

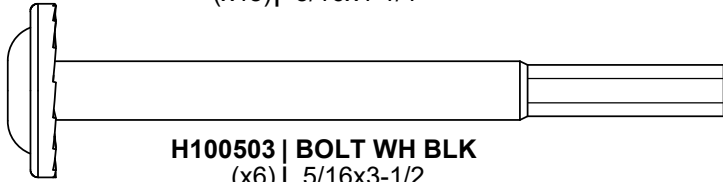

H100503 | BOLT WH BLK
(x6) | 5/16x3-1/2

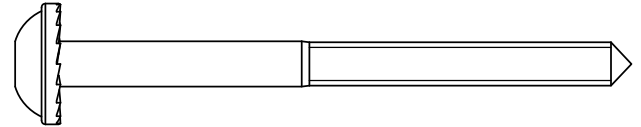

H100792 | LAG SCREW WH BLK
(x8) | 1/4x3

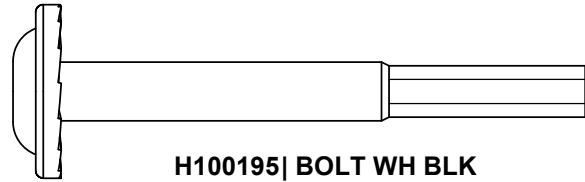

H100195 | BOLT WH BLK
(x75) | 5/16x2-3/4

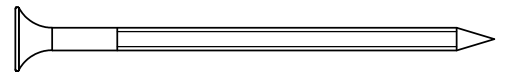

H100201 | SCREW PFH BLK
(x32) | 8x2-1/2

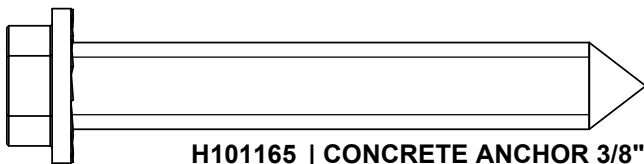

H101165 | CONCRETE ANCHOR 3/8"x3" BLK
(x5) | 3/8x3

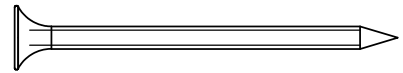

H100391 | SCREW PFH BLK
(x211) | 8x2

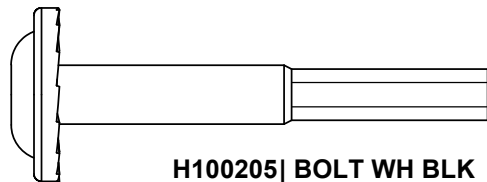

H100205 | BOLT WH BLK
(x4) | 5/16x2-1/4

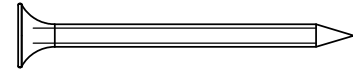

H100382 | SCREW PFH BLK
(x400) | 8x1-3/4

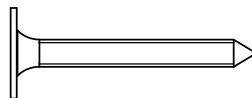

H101203 | SCREW PWH BLK
(x30) | 8x1 1/4

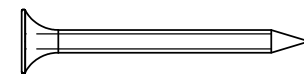

H100200 | SCREW PFH BLK
(x56) | 8x1-1/2

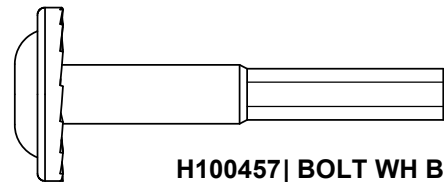

H100457 | BOLT WH BLK
(x9) | 5/16x2

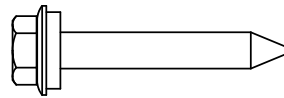

H101206 | SCREW WOODGRIP
(x36) | 10-16x1-1/4"

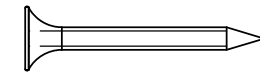

H100387 | SCREW PFH BLK
(x80) | 8x1-1/4

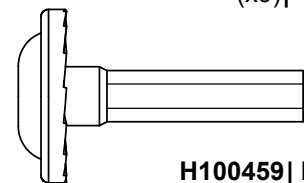

H100459 | BOLT WH BLK
(x1) | 5/16x1-1/4

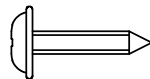

H100202 | SCREW PWH 8 x 5/8 BLK
(x4) | 8x5/8

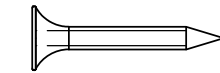

H100385 | SCREW PFH BLK
(x26) | 8x1

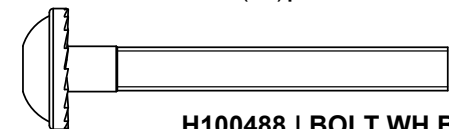

H100488 | BOLT WH BLK
(x36) | 1/4x2

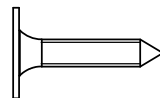

H101205 | SCREW PWH BLK
(x24) | 8x3/4

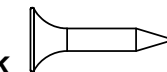

H100395 | SCREW PFH BLK
(x2) | 8x3/4

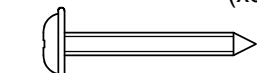

H100797 | SCREW PWH BLK
(x35) | 8x1



H100627 | SCREW PFH BLK
(x8) | 6x3/4

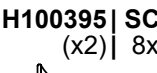

H100411 | SCREW PFH BLK
(x1) | 8x5/8

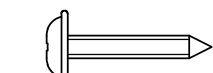

H100392 | SCREW PWH BLK
(x4) | 8x3/4

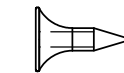

H100203 | SCREW PFH BLK
(x2) | 8x1/2

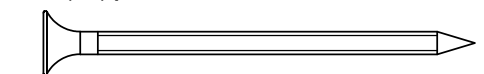

H100483 | SCREW PFH 8 x 2 1/4 BLK
(x70) | 8x2-1/4

OWNER'S MANUAL - PARTS IDENTIFICATION

Hardware Components

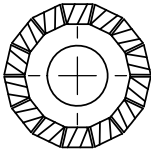

H100198 | WASHER LOCK EXT BLK
(x143) | 8x19

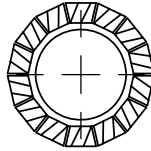

H100199 | WASHER LOCK EXT BLK
(x1) | 12x19

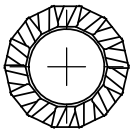

H100400 | WASHER LOCK EXT BLK
(x8) | 8x15

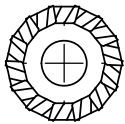

H100405 | WASHER LOCK EXT BLK
(x42) | 6x15

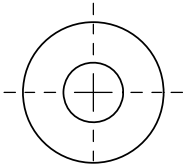

H100630 | WASHER FLAT BLK
(x28) | 8x19

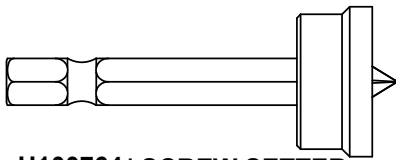

H100764 | SCREW SETTER
(x1)

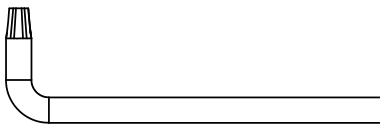

H100114 | TORX WRENCH
(x1) | T-30

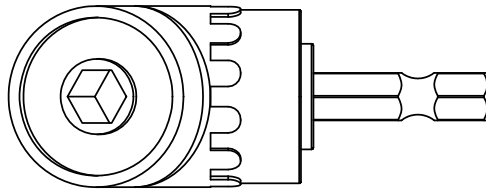

**H101114 | RIGHT ANGLE DRILL
ADAPTER**
(x1)

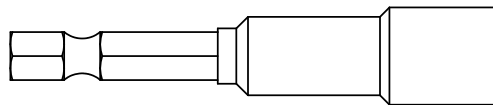

H101106 | SOCKET DRIVER
(x1)



H100193 | NUT BARREL WH BLK
(x19) | 5/16x1-1/2

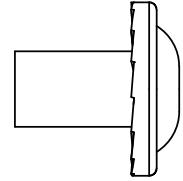

H100469 | NUT BARREL WH BLK
(x1) | 5/16x5/8

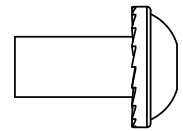

H100404 | NUT BARREL WH BLK
(x8) | 1/4x5/8

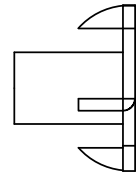

H100379 | T-NUT BLK
(x123) | 5/16



H100653 | NUT LOCK BLK
(x28) | 1/4

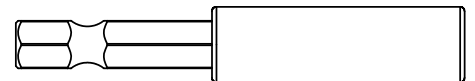

H101100 | MAGNETIC DRIVER
(x1)

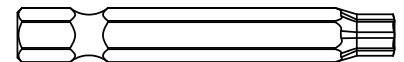

H100147 | TORX BIT
(x1) | T-30

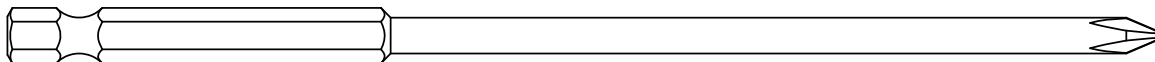

H101261 | PHILLIPS EXTENSION BIT
(x1)

STEP 1 - BACK FRAME

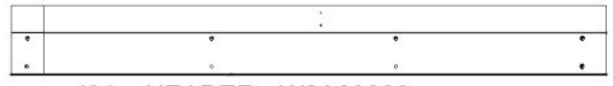

J01 HEADER - W2A03980
(x1) 1 7/16"x8 7/16"x72 1/2" (36x214x1842)



E06 RUNNING BOARD - W4L18702
(x1) 1 7/16"x3 3/8"x72 1/2" (36x86x1842)



D01 BASE BOARD - W4L18684
(x1) 1 7/16"x5 1/4"x71 3/4" (36x134x1822)

Qty	PART NUMBER	DESCRIPTION
10	H100195	BOLT WH 5/16 X 2 3/4 BLK
16	H100198	WASHER LOCK EXT 8X19 BLK
16	H100379	T-NUT 5/16 BLK
6	H100513	BOLT WH 5/16 X 4 1/4 BLK



F01 VERTICAL UPRIGHT - W4L18680
(x2) 1 7/16"x2 3/8"x74 3/8" (36x60x1889)



B03 POST - W4L18678
(x1) 3"x3"x74 3/8" (76x76x1889)

TIP: USE OF SAWHORSES IS RECOMMENDED DURING THE ASSEMBLY OF ALL WALL ASSEMBLIES.

NOTES:

- INSERT T-NUTS FIRST
- HAND TIGHTEN ONLY

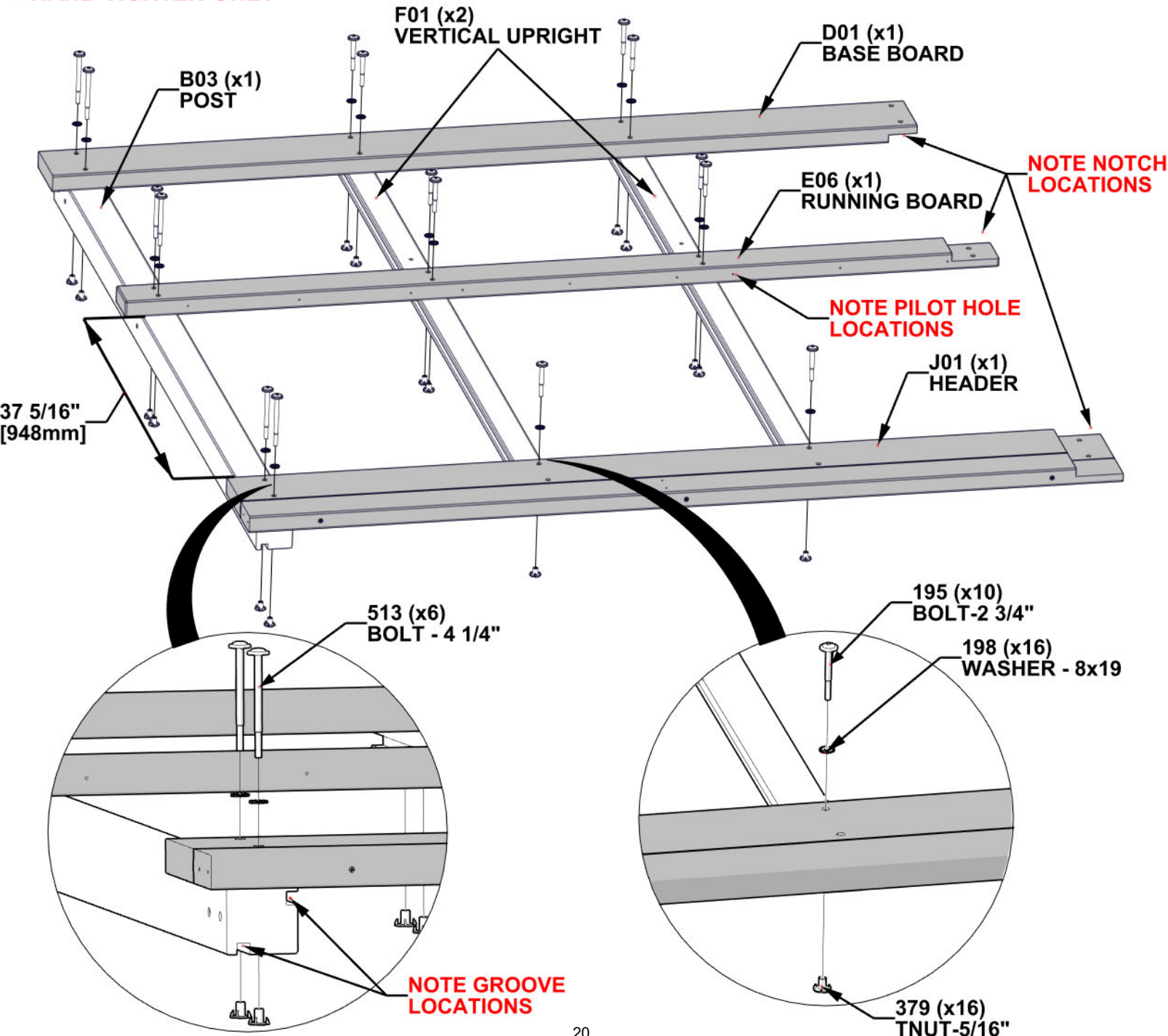

**SET STEP 1 ASSEMBLY
TO THE SIDE**

STEP 2 - BACK FRAME

Qty	PART NUMBER	DESCRIPTION
10	H100195	BOLT WH 5/16 X 2 3/4 BLK
16	H100198	WASHER LOCK EXT 8X19 BLK
16	H100379	T-NUT 5/16 BLK
6	H100513	BOLT WH 5/16 X 4 1/4 BLK

- J02 HEADER - W2A03981
(x1) 1 7/16"x8 7/16"x72 1/2" (36x214x1842)
- E20 RUNNING BOARD - W4L18731
(x1) 1 7/16"x3 3/8"x72 1/2" (36x86x1842)
- D07 BASE BOARD - W4L18730
(x1) 1 7/16"x5 1/4"x71 3/4" (36x134x1822)

- B02 POST - W4L18677
(x1) 3"x3"x74 3/8" (76x76x1889)
- F01 VERTICAL UPRIGHT - W4L18680
(x1) 1 7/16"2 3/8"x74 3/8" (36x60x1889)
- F11 VERTICAL UPRIGHT - W4L18675
(x1) 1 7/16"2 3/8"x74 3/8" (36x60x1889)

NOTES:
 • INSERT T-NUTS FIRST
 • HAND TIGHTEN ONLY

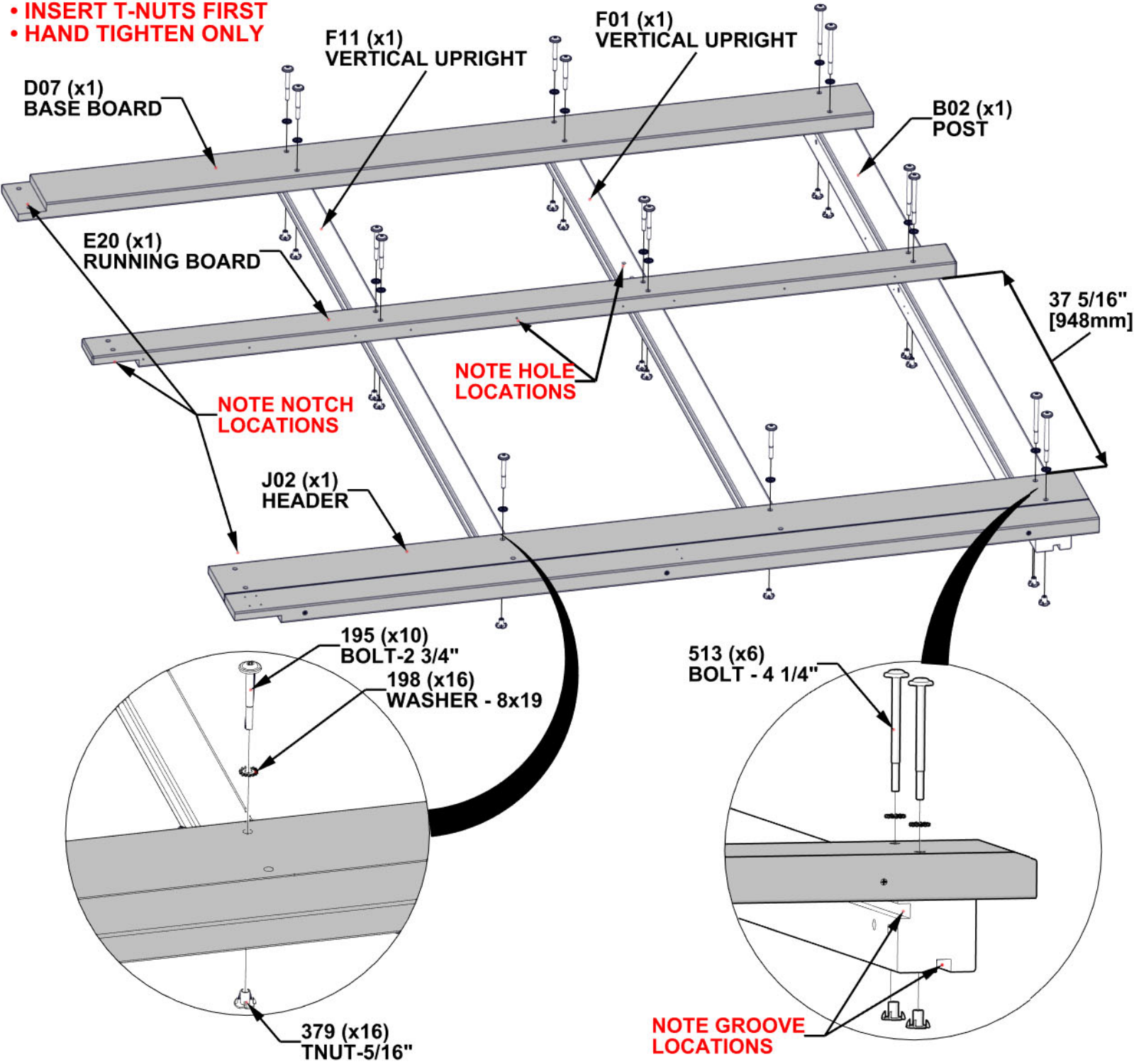

STEP 3 - BACK FRAME

Qty	PART NUMBER	DESCRIPTION
5	H100195	BOLT WH 5/16 X 2 3/4 BLK
5	H100198	WASHER LOCK EXT 8X19 BLK
5	H100379	T-NUT 5/16 BLK



F01 VERTICAL UPRIGHT - W4L18680
 (x1) 1 7/16" x 2 3/8" x 74 3/8" (36x60x1889)

- NOTES:**
- INSERT T-NUTS FIRST
 - HAND TIGHTEN ONLY

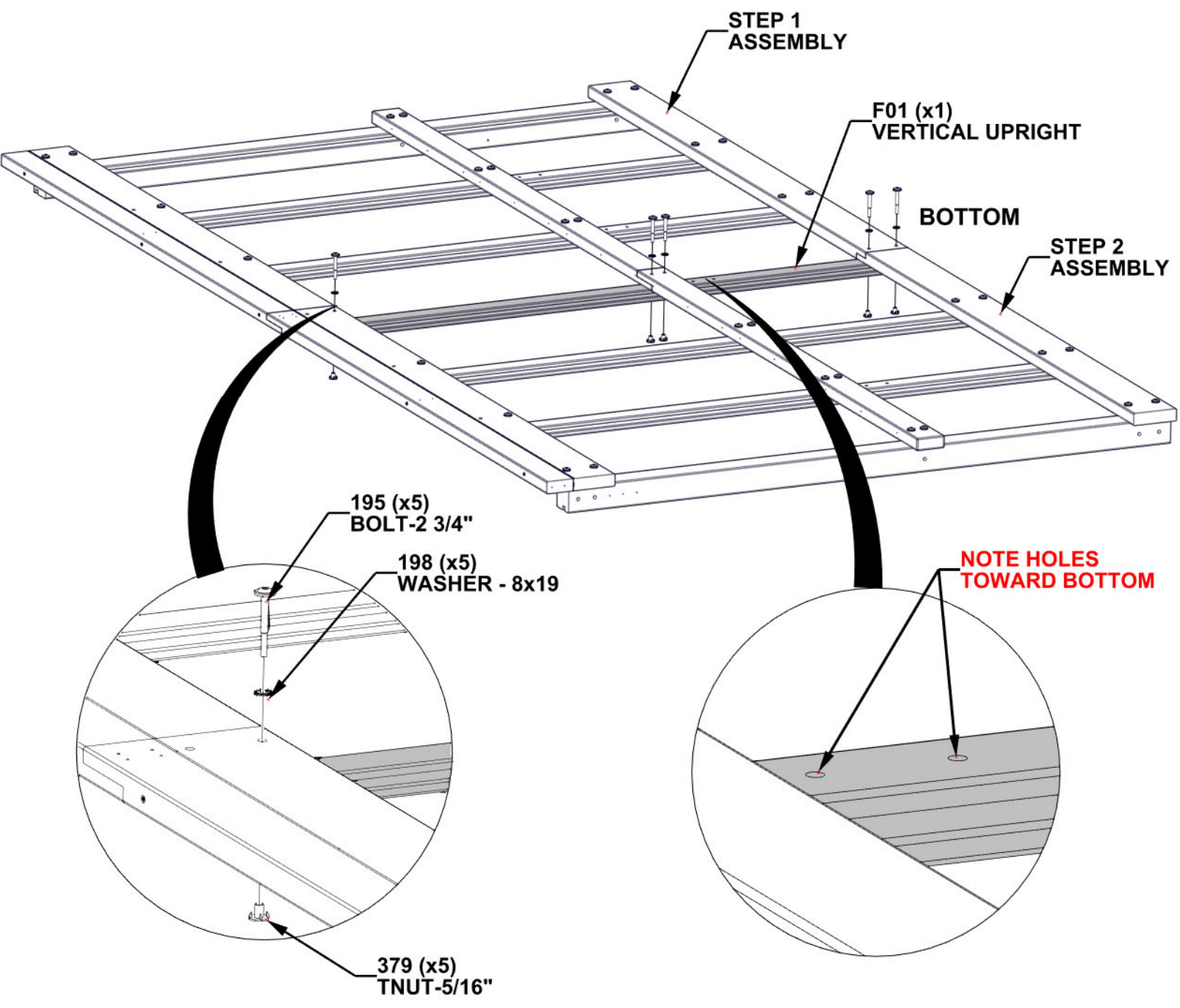

**SET STEP 3 ASSEMBLY
TO THE SIDE**

STEP 4 - LEFT FRAME

Qty	PART NUMBER	DESCRIPTION
15	H100195	BOLT WH 5/16 X 2 3/4 BLK
20	H100198	WASHER LOCK EXT 8X19 BLK
20	H100379	T-NUT 5/16 BLK
5	H100513	BOLT WH 5/16 X 4 1/4 BLK

- J05 HEADER - W2A03984
(x1) 1 7/16"x8 7/16"x86 1/4" (36x214x2190)
- E27 RUNNING BOARD - W4L18700
(x1) 1 7/16"x3 3/8"x83 7/16" (36x86x2119)
- D02 BASE BOARD - W4L18685
(x1) 1 7/16"x5 1/4"x83 7/16" (36x134x2119)
- F02 VERTICAL UPRIGHT - W4L18681
(x1) 1 7/16"x2 3/8"x78 3/4" (36x60x2000)

- B04 POST - W4L18679
(x1) 3"x3"x89 5/16" (76x76x2269)
- F04 VERTICAL UPRIGHT - W4L18683
(x1) 1 7/16"x2 3/8"x85 13/16" (36x60x2179)
- F03 VERTICAL UPRIGHT - W4L18682
(x1) 1 7/16"x2 3/8"x82 1/4" (36x60x2089)

NOTES:
 • INSERT T-NUTS FIRST
 • HAND TIGHTEN ONLY

NOTE PILOT HOLES UPWARD

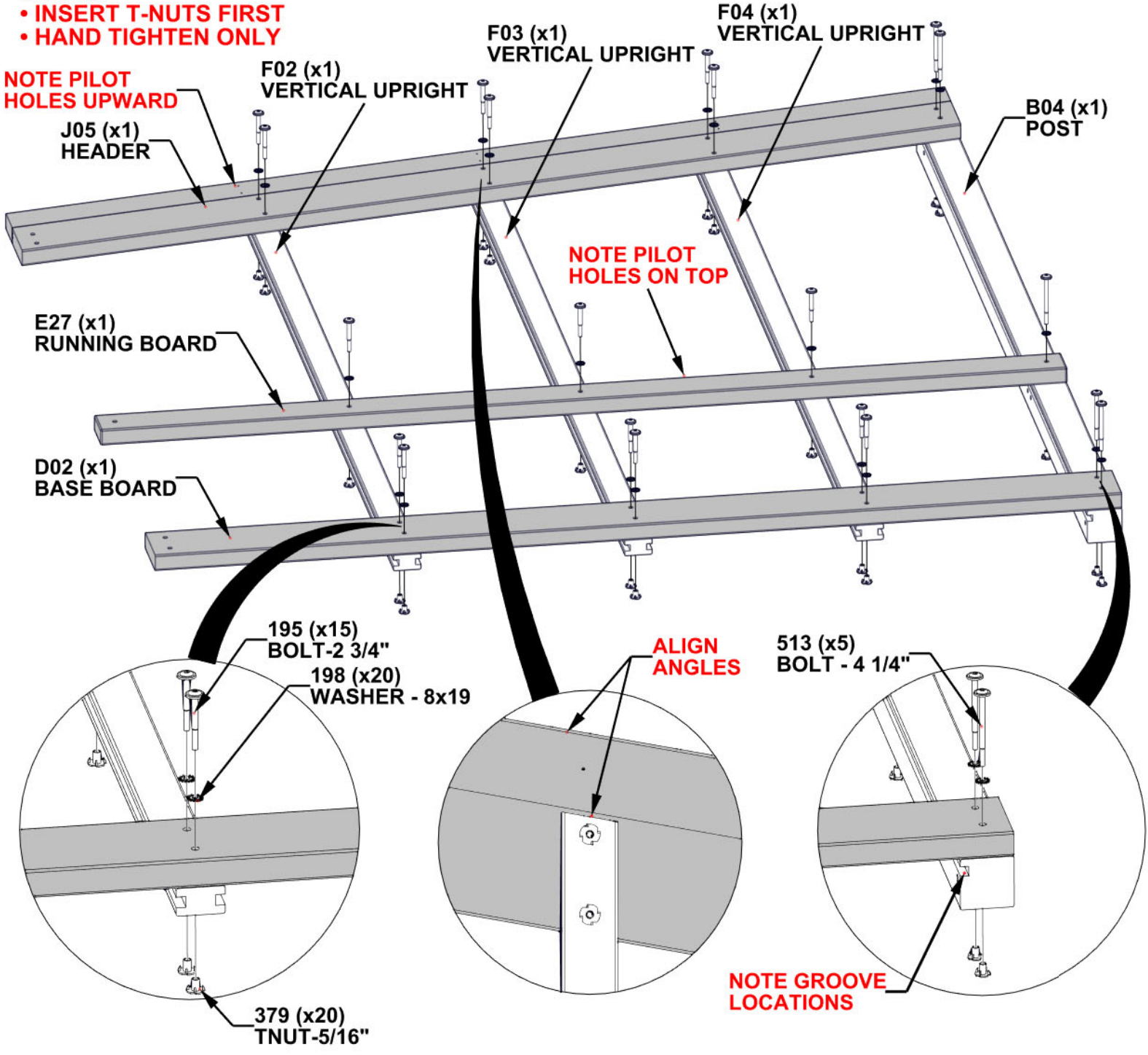

NOTE PILOT HOLES ON TOP

ALIGN ANGLES

NOTE GROOVE LOCATIONS

STEP 5 - FRAME ASSEMBLY

Qty	PART NUMBER	DESCRIPTION
2	H100193	NUT BARREL WH 5/16 X 1 1/2 BLK
5	H100198	WASHER LOCK EXT 8X19 BLK
3	H100379	T-NUT 5/16 BLK
2	H100503	BOLT WH 5/16 X 3 1/2 BLK
3	H100513	BOLT WH 5/16 X 4 1/4 BLK

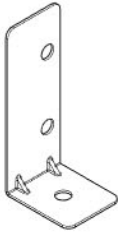

A4M02503 ANCHOR BRACKET
(x1)

- NOTES:**
- INSERT T-NUTS FIRST
 - HAND TIGHTEN ONLY
 - EXTRA PEOPLE NEEDED FOR THIS STEP

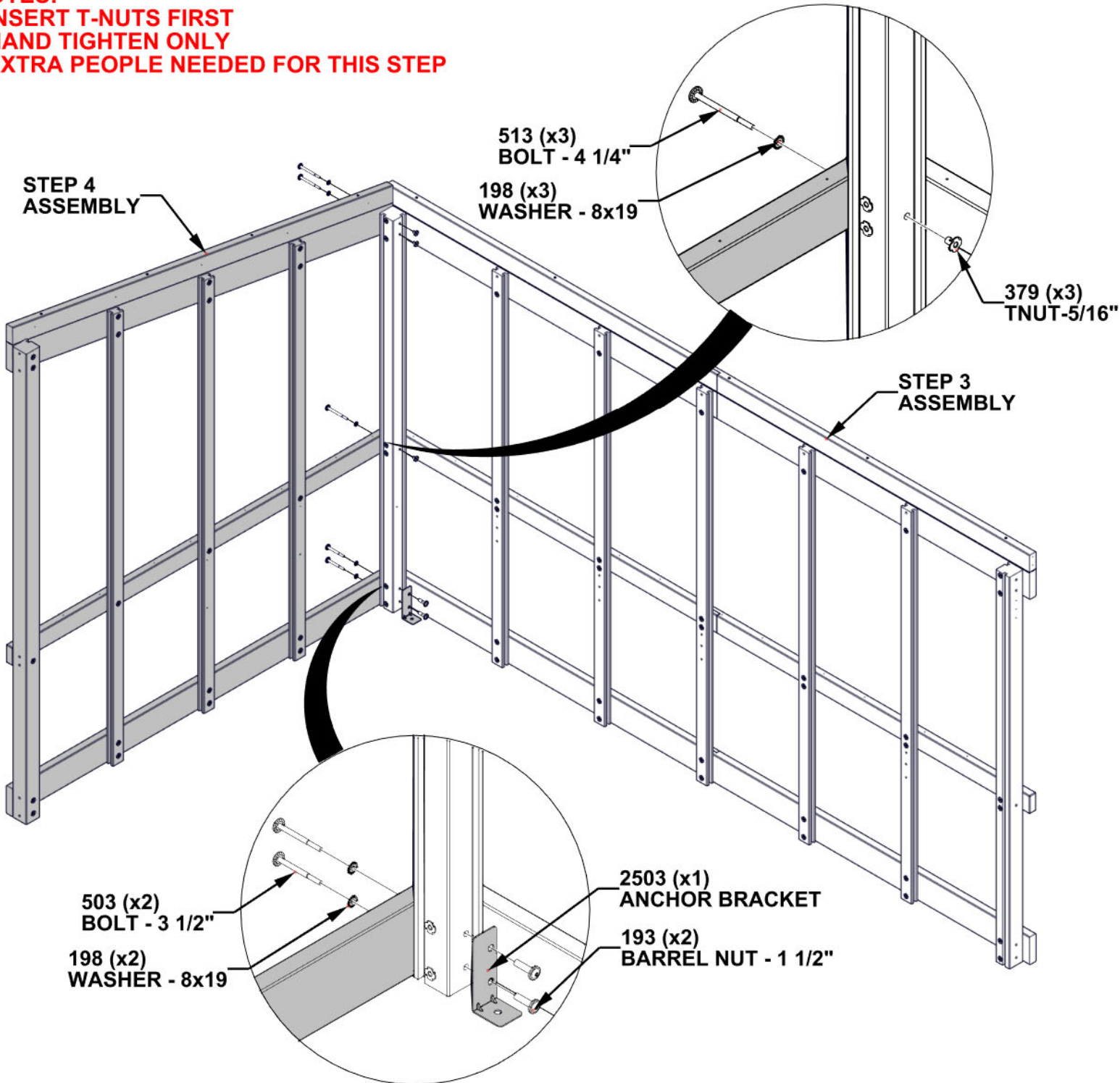

**SET STEP 5 ASSEMBLY
TO THE SIDE**

STEP 6A - RIGHT FRAME

Qty	PART NUMBER	DESCRIPTION
5	H100195	BOLT WH 5/16 X 2 3/4 BLK
15	H100198	WASHER LOCK EXT 8X19 BLK
15	H100379	T-NUT 5/16 BLK
10	H100513	BOLT WH 5/16 X 4 1/4 BLK



J06 HEADER - W2A03985
(x1) 1 7/16"x8 7/16"x86 1/4" (36x214x2190)



E07 RUNNING BOARD - W4L18703
(x1) 1 7/16"x3 3/8"x83 7/16" (36x86x2119)

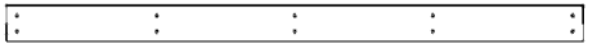

D02 BASE BOARD - W4L18685
(x1) 1 7/16"x5 1/4"x83 7/16" (36x134x2119)



B05 VERTICAL UPRIGHT - W4L18686
(x1) 3"x3"x85 3/4" (76x76x2178)



F06 VERTICAL UPRIGHT - W4L18726
(x1) 1 7/16"2 3/8"x82 1/4" (36x60x2089)



B06 VERTICAL UPRIGHT - W4L18687
(x1) 3"x3"x78 3/4" (76x76x2000)

- NOTES:**
- INSERT T-NUTS FIRST
 - HAND TIGHTEN ONLY

NOTE PILOT HOLE LOCATIONS

B06 (x1) VERTICAL UPRIGHT

F06 (x1) VERTICAL UPRIGHT

B05 (x1) VERTICAL UPRIGHT

J06 (x1) HEADER

E07 (x1) RUNNING BOARD

D02 (x1) BASE BOARD

NOTE PILOT HOLES ON TOP

NOTE PILOT HOLES ON B05 & B06 SHOULD BE FACING OUTWARD

ALIGN ANGLES

379 (x15) TNUT-5/16"

198 (x15) WASHER - 8x19

195 (x5) BOLT-2 3/4"

513 (x10) BOLT - 4 1/4"

STEP 6B - RIGHT FRAME

Qty	PART NUMBER	DESCRIPTION
2	H100193	NUT BARREL WH 5/16 X 1 1/2 BLK
5	H100198	WASHER LOCK EXT 8X19 BLK
3	H100379	T-NUT 5/16 BLK
2	H100503	BOLT WH 5/16 X 3 1/2 BLK
3	H100513	BOLT WH 5/16 X 4 1/4 BLK

B01 POST - W4L18676
 (x1) 3"x3"x89 5/16" (76x76x2269)

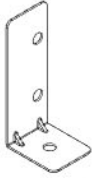

A4M02503 ANCHOR BRACKET
 (x1)

NOTES:
 • INSERT T-NUTS FIRST
 • HAND TIGHTEN ONLY

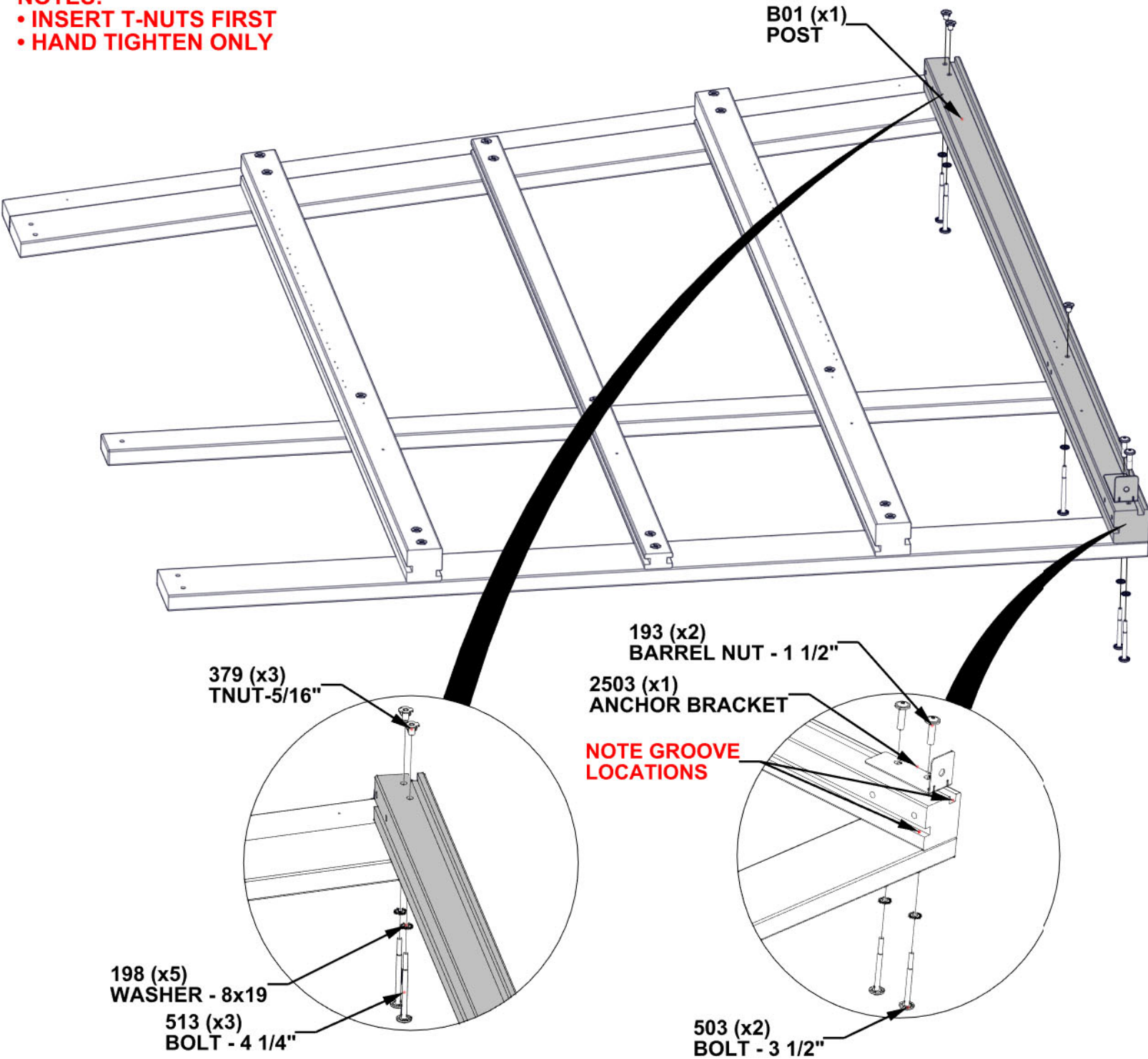

STEP 7 - FRAME ASSEMBLY

Qty	PART NUMBER	DESCRIPTION
2	H100193	NUT BARREL WH 5/16 X 1 1/2 BLK
5	H100198	WASHER LOCK EXT 8X'9 BLK
3	H100379	T-NUT 5/16 BLK
2	H100503	BOLT WH 5/16 X 3 1/2 BLK
3	H100513	BOLT WH 5/16 X 4 1/4 BLK

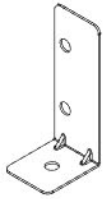

A4M02502 ANCHOR BRACKET
(x1)

- NOTES:**
- INSERT T-NUTS FIRST
 - HAND TIGHTEN ONLY
 - EXTRA PEOPLE NEEDED FOR THIS STEP

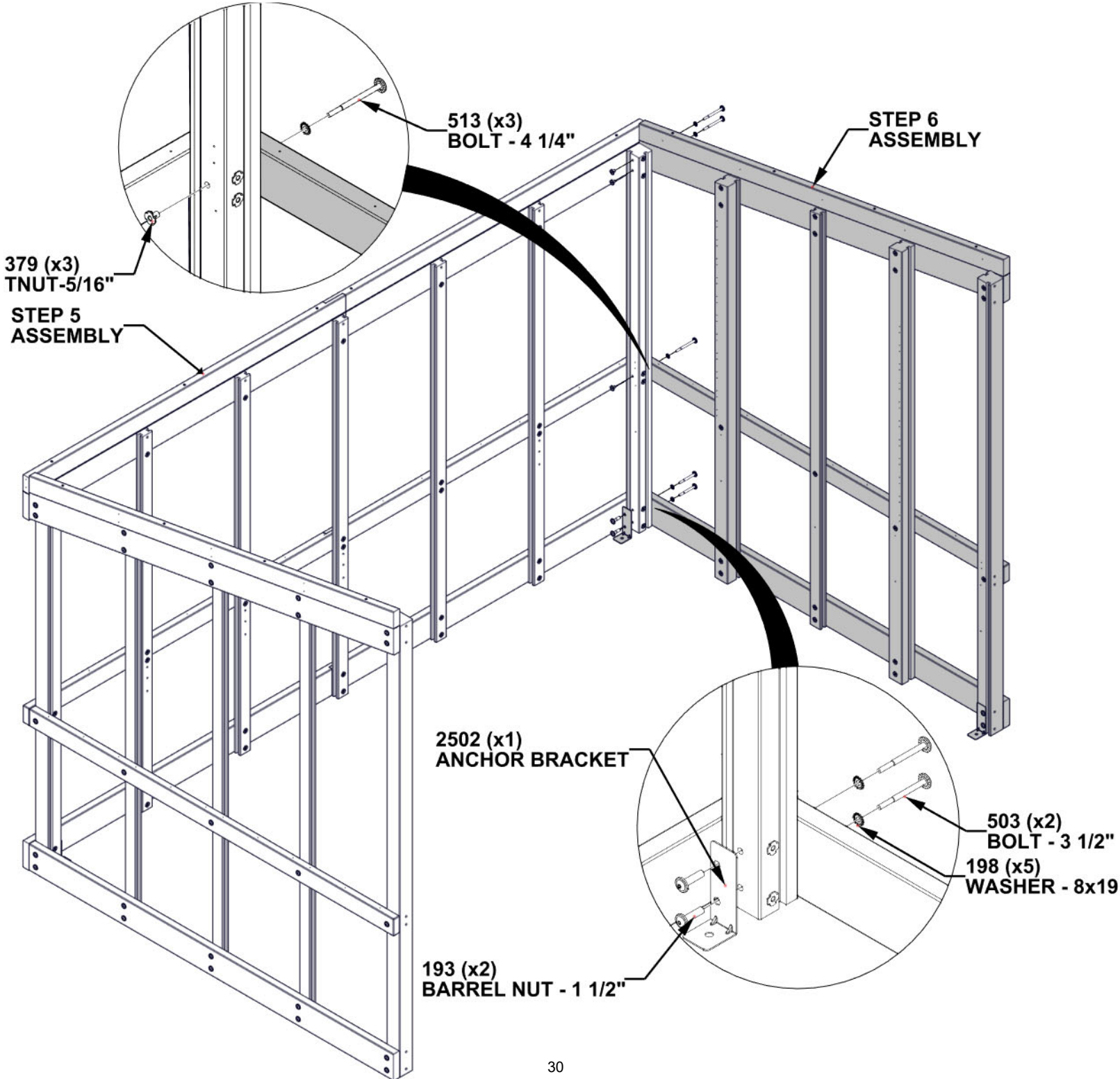

**SET STEP 7 ASSEMBLY
TO THE SIDE**

STEP 8A - FRONT FRAME

Qty	PART NUMBER	DESCRIPTION
2	H100193	NUT BARREL WH 5/16 X 1 1/2 BLK
10	H100195	BOLT WH 5/16 X 2 3/4 BLK
12	H100198	WASHER LOCK EXT 8X19 BLK
2	H100205	BOLT WH 5/16 X 2 1/4 BLK
10	H100379	T-NUT 5/16 BLK



F05 VERTICAL UPRIGHT - W4L18704
(x1) 1 7/16" x 2 3/8" x 89 5/16" (36x60x2269)

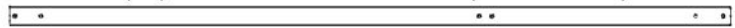

F10 VERTICAL UPRIGHT - W4L18674
(x1) 1 7/16" x 2 3/8" x 89 5/16" (36x60x2269)



B07 POST - W4L18707
(x1) 3"x3"x89 5/16" (76x76x2269)

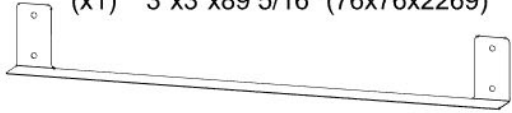

A4M02495 DOOR BRACKET
(x1)



A4M02096 BRACKET
(x1)



E09 RUNNING BOARD - W4L18709
(x1) 1 7/16" x 3 3/8" x 51" (36x86x1296)



D05 BASE BOARD - W4L18706
(x1) 1 7/16" x 5 1/4" x 50 1/4" (36x134x1276)

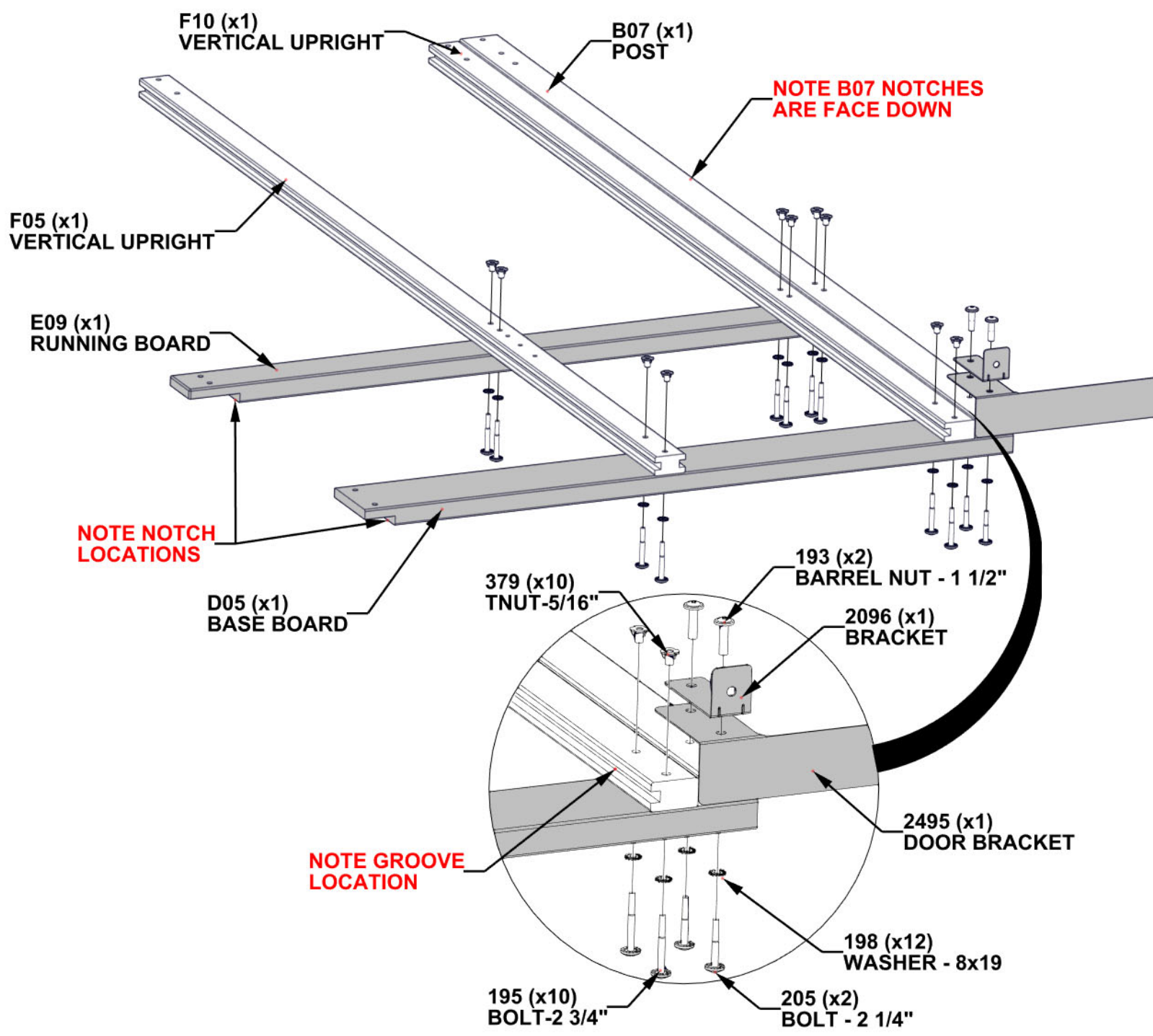

STEP 8B - FRONT FRAME

Qty	PART NUMBER	DESCRIPTION
2	H100193	NUT BARREL WH 5/16 X 1 1/2 BLK
9	H100195	BOLT WH 5/16 X 2 3/4 BLK
11	H100198	WASHER LOCK EXT 8X19 BLK
2	H100205	BOLT WH 5/16 X 2 1/4 BLK
9	H100379	T-NUT 5/16 BLK

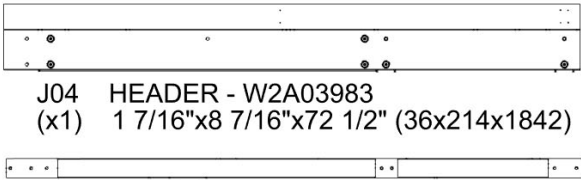

J04 HEADER - W2A03983
(x1) 1 7/16"x8 7/16"x72 1/2" (36x214x1842)

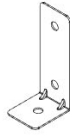

A4M02096 BRACKET
(x1)

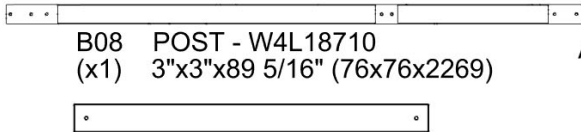

B08 POST - W4L18710
(x1) 3"x3"x89 5/16" (76x76x2269)



E10 DOOR TRIM - W4L18711
(x1) 1 7/16"x3 3/8"x42 1/2" (36x86x1080)



E11 RUNNING BOARD - W4L18712
(x1) 1 7/16"x3 3/8"x7 3/8" (36x86x188)

D06 BASE BOARD - W4L18713
(x) 1 7/16"x5 1/4"x7 3/8" (36x134x188)

- NOTES:**
 • INSERT T-NUTS FIRST
 • HAND TIGHTEN ONLY

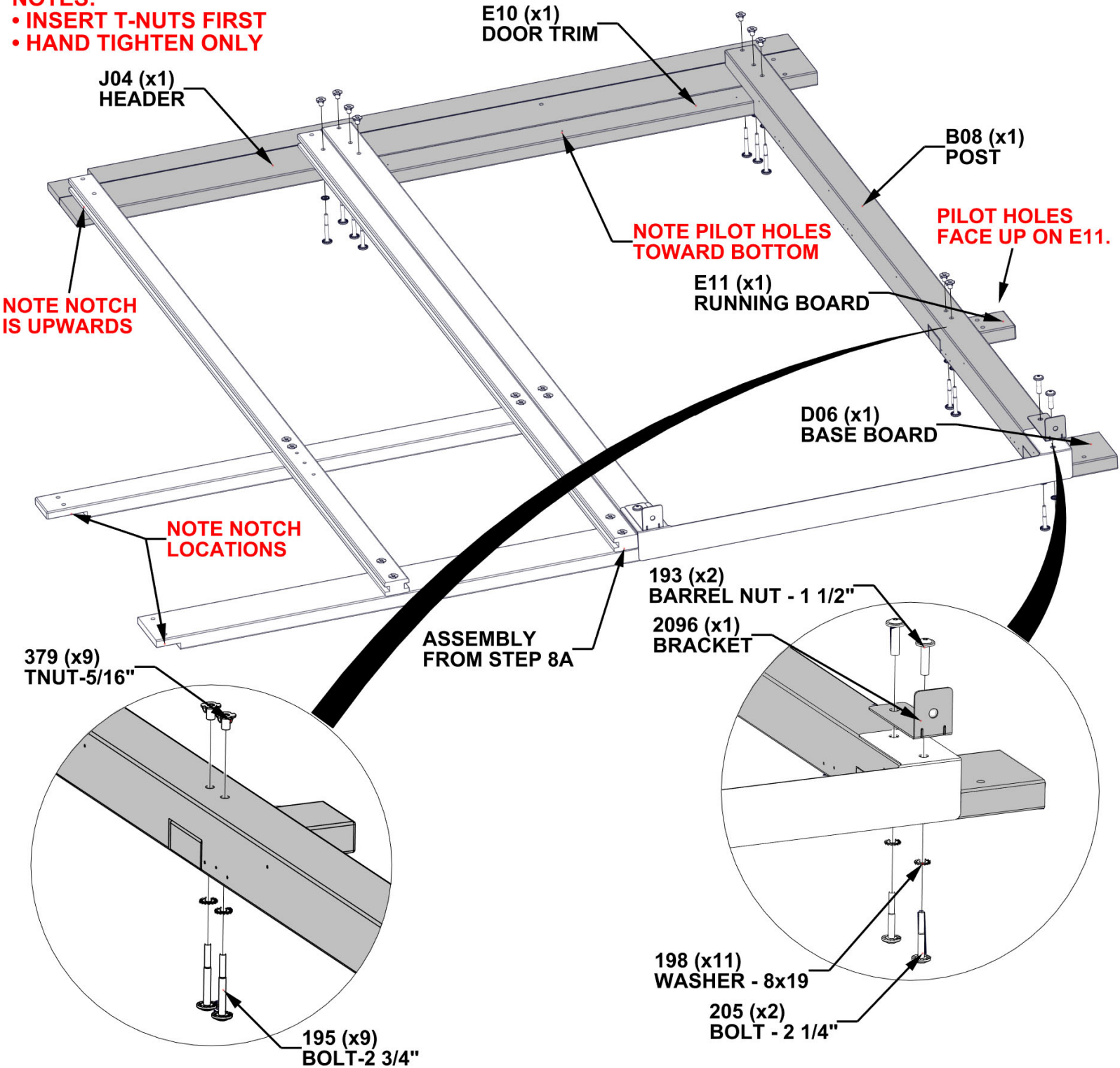

STEP 8C - FRONT FRAME

Qty	PART NUMBER	DESCRIPTION
11	H100195	BOLT WH 5/16 X 2 3/4 BLK
11	H100198	WASHER LOCK EXT 8X19 BLK
11	H100379	T-NUT 5/16 BLK

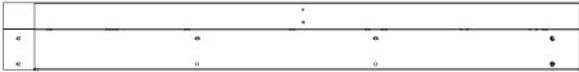

J03 HEADER - W2A03982
(x1) 1 7/16"x8 7/16"x72 1/2" (36x214x1842)



E08 RUNNING BOARD - W4L18708
(x1) 1 7/16"x3 3/8"x50 1/16" (36x86x1272)



D04 BASE BOARD - W4L18705
(x1) 1 7/16"x5 1/4"x49 5/16" (36x134x1252)



F05 VERTICAL UPRIGHT - W4L18704
(x1) 1 7/16"x2 3/8"x89 5/16" (36x60x2269)



F12 VERTICAL UPRIGHT - W4L18699
(x1) 1 7/16"x2 3/8"x89 5/16" (36x60x2269)

- NOTES:**
- INSERT T-NUTS FIRST
 - HAND TIGHTEN ONLY

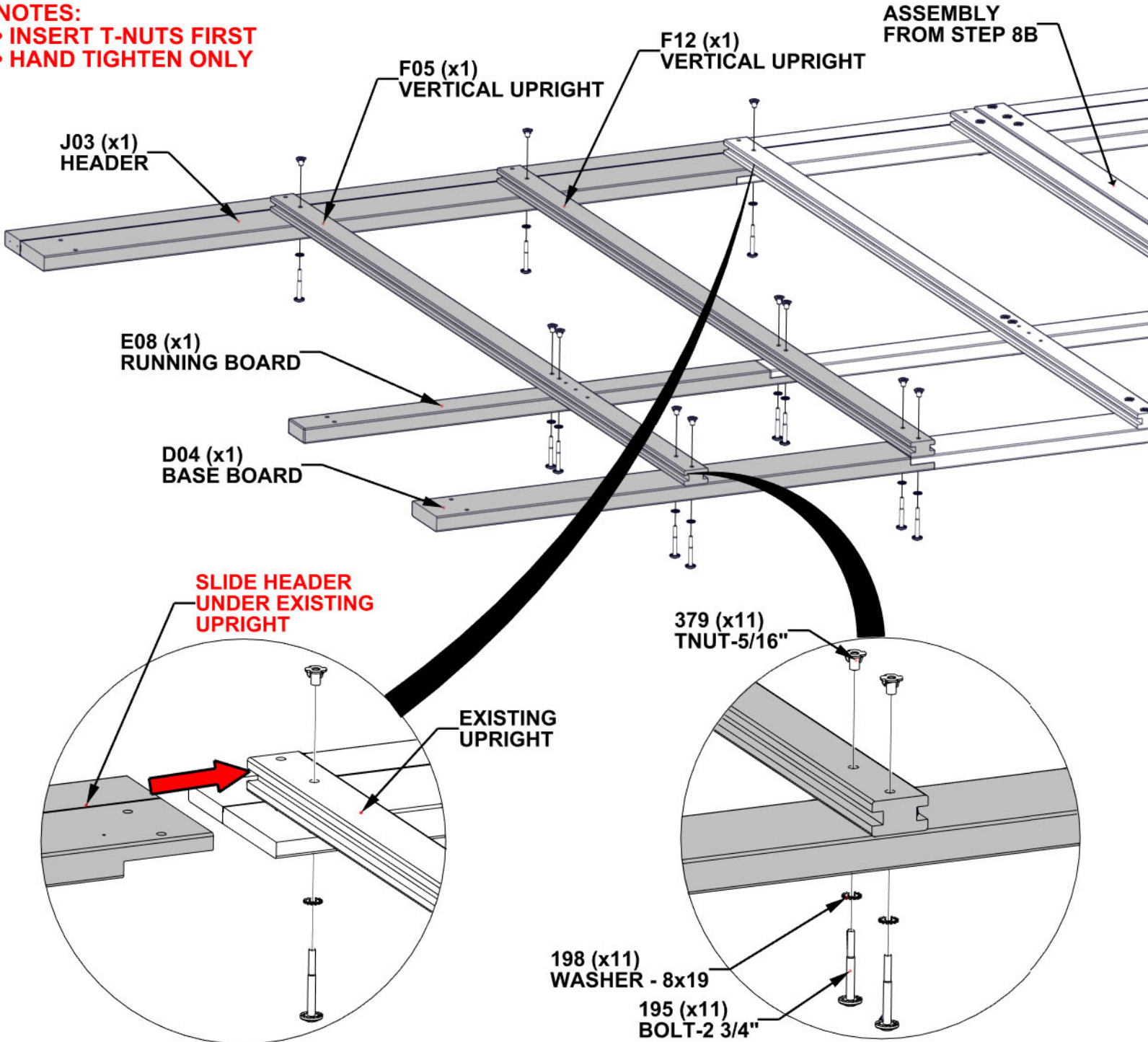

STEP 9 - FRAME ASSEMBLY

Qty	PART NUMBER	DESCRIPTION
12	H100198	WASHER LOCK EXT 8X19 BLK
12	H100379	T-NUT 5/16 BLK
12	H100513	BOLT WH 5/16 X 4 1/4 BLK

- NOTES:**
- INSERT T-NUTS FIRST
 - HAND TIGHTEN ONLY
 - EXTRA PEOPLE NEEDED FOR THIS STEP

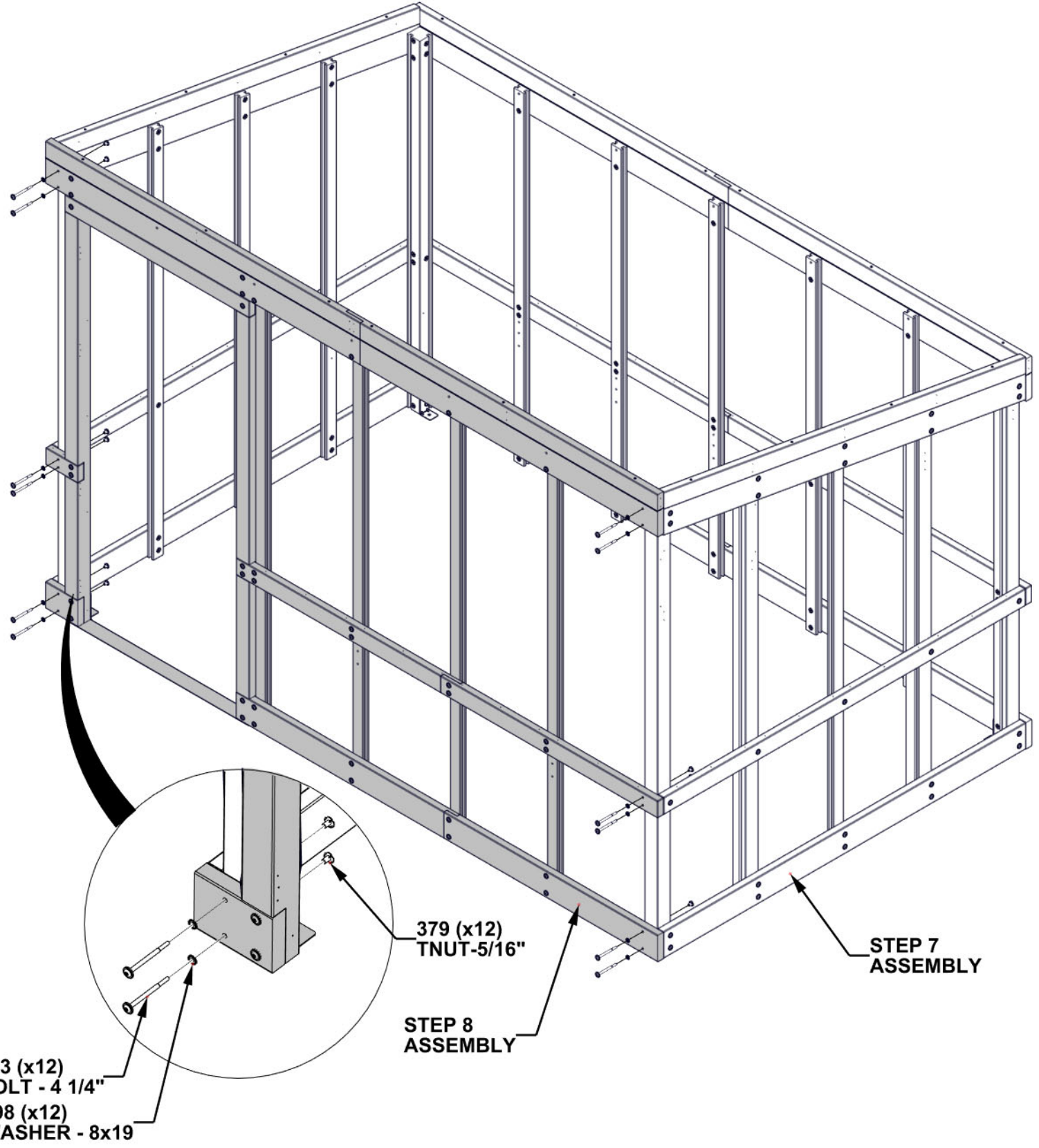

STEP 10 - SQUARE ASSEMBLY

CRITICAL!!

- CHECK TO MAKE SURE ALL UPRIGHTS ARE SQUARE.
- MEASURE FROM INTERIOR CORNER TO INTERIOR CORNER;
- IF SQUARE, DIMENSIONS WILL MATCH.
- ONCE CONFIRMED SQUARE, TIGHTEN ALL HARDWARE.

FAILURE TO MAKE UNIT SQUARE WILL IMPACT THE REMAINING SETUP PROCESS!

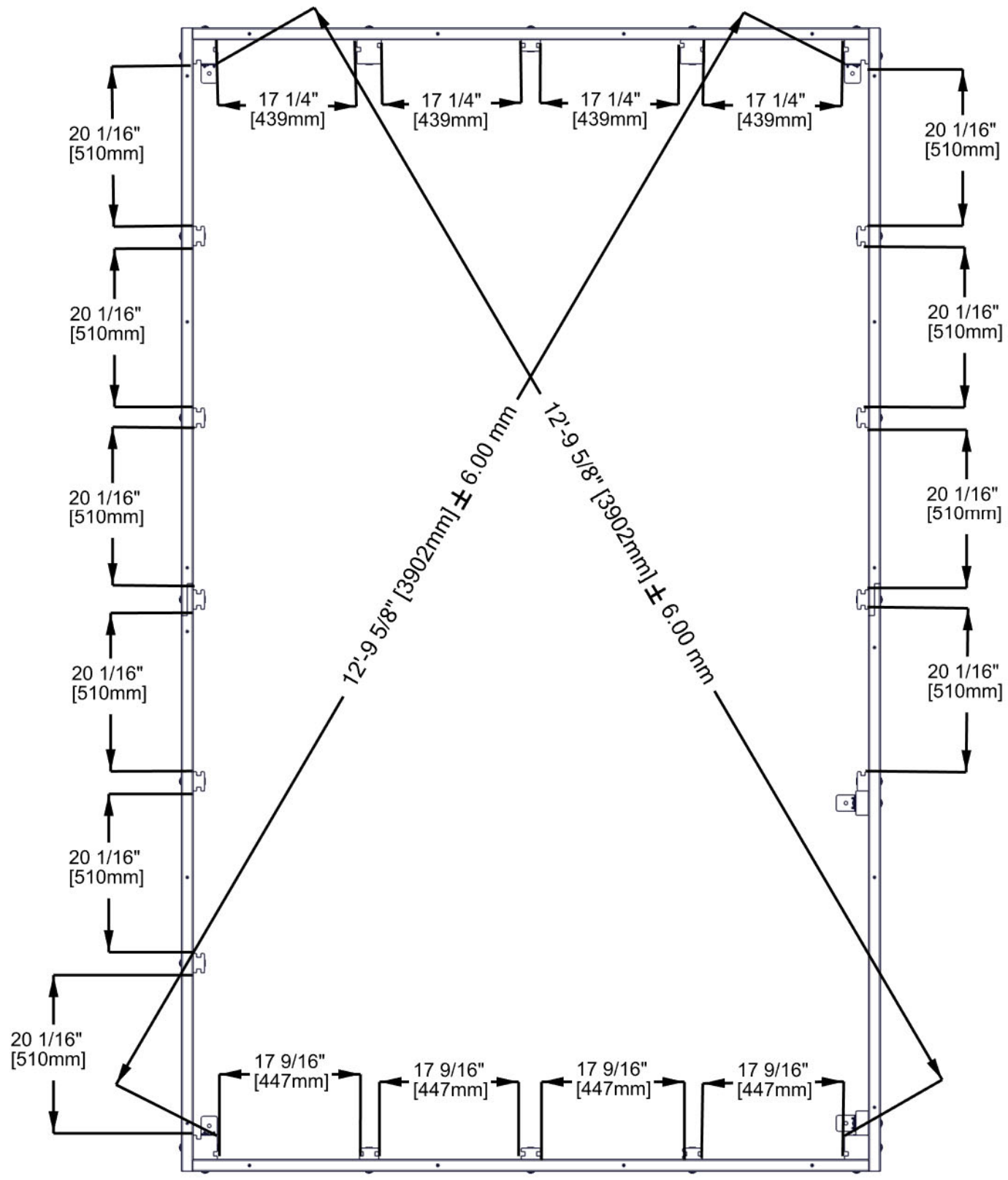

STEP 11 - BACK WALL BOARDS

Qty	PART NUMBER	DESCRIPTION
144	H100382	SCREW PFH 8 X 1 3/4 BLK



Q01 WALL BOARD - W4L18688
(x30) 15/16"x4"x32 1/16" (24x98x814)



Q02 WALL BOARD - W4L18689
(x6) 15/16"x3 15/16"x32 1/16" (24x100x814)

NOTES:
MAKE SURE BOARDS ARE FLUSH WITH RUNNING BOARD AND EVENLY SPACED BEFORE INSERTING SCREWS.

INSERT WALL BOARDS INTO GROOVE ON POST/UPRIGHTS

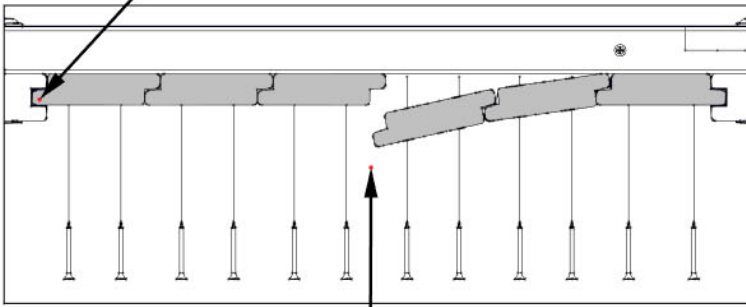

TO GET ALL BOARDS TO PROPERLY SEAT MAY REQUIRE POSITIONING BOARDS AS SHOWN AND INSERTING TONGUE INTO GROOVE.

Q02 (x6) WALL BOARD
Q01 (x30) WALL BOARD
RUNNING BOARD

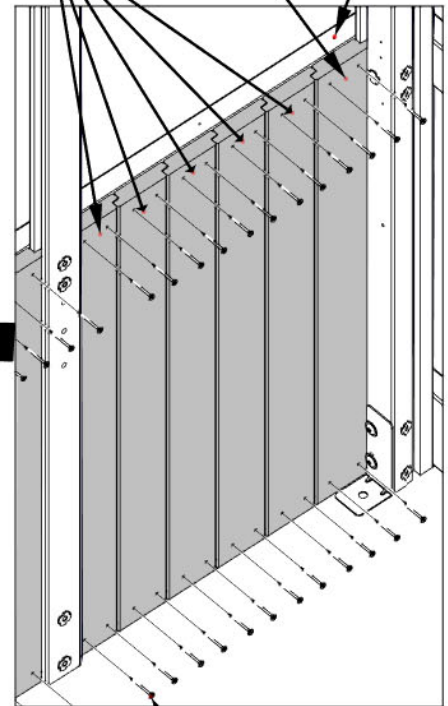

382 (x144) SCREW - 1 3/4"

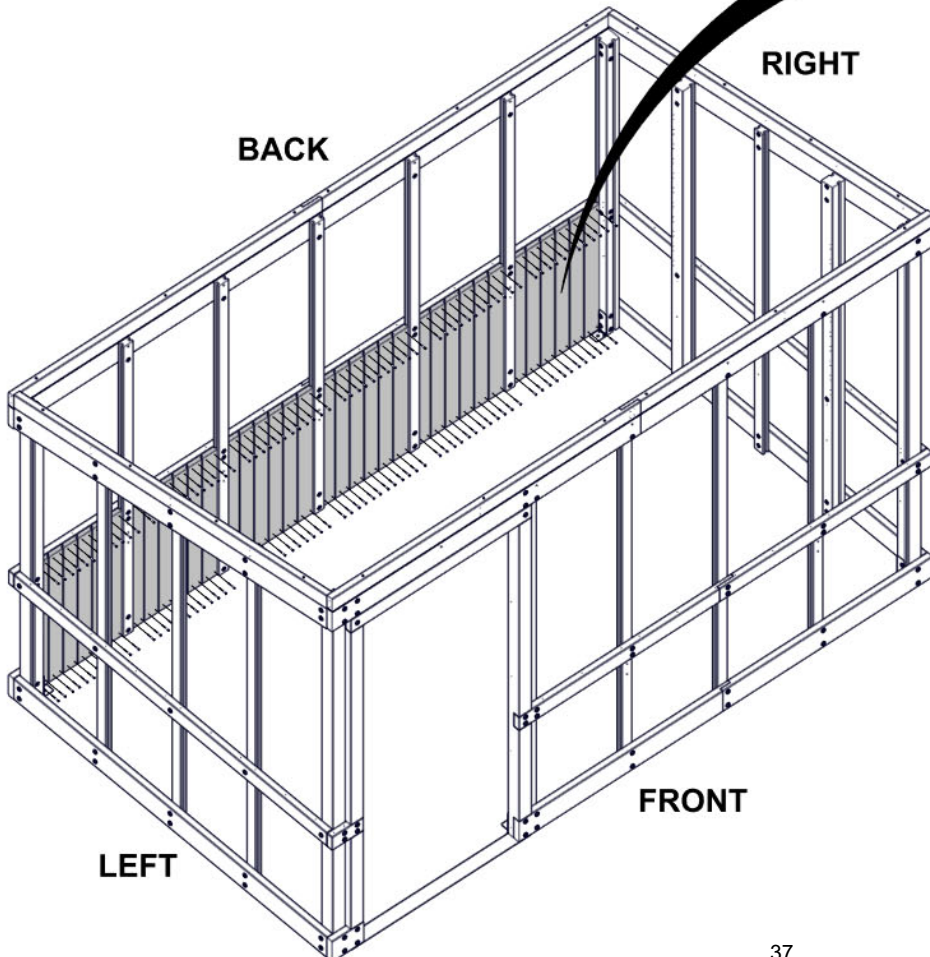

STEP 12A - LEFT WALL BOARDS

Qty	PART NUMBER	DESCRIPTION
40	H100382	SCREW PFH 8 X 1 3/4 BLK

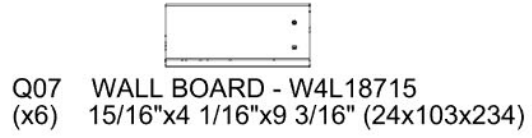
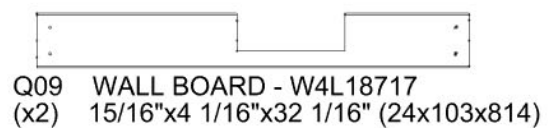
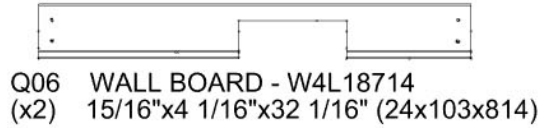

- NOTES:**
- INSTALL Q09 & Q06 FIRST, THEN INSTALL EVENLY SPACED Q07 LOWER BOARDS FLUSH WITH BOTTOM OF BASE BOARD.
 - INSTALL EVENLY SPACED Q08 UPPER BOARDS AND HOLD FLUSH WITH TOP HORIZONTAL WALL BOARD.
 - BEFORE ADDING SCREWS, CONFIRM THE DIMENSIONS REQUIRED FOR THE LOUVER.

HOLD DIMENSIONS FOR PROPER LOUVER FIT

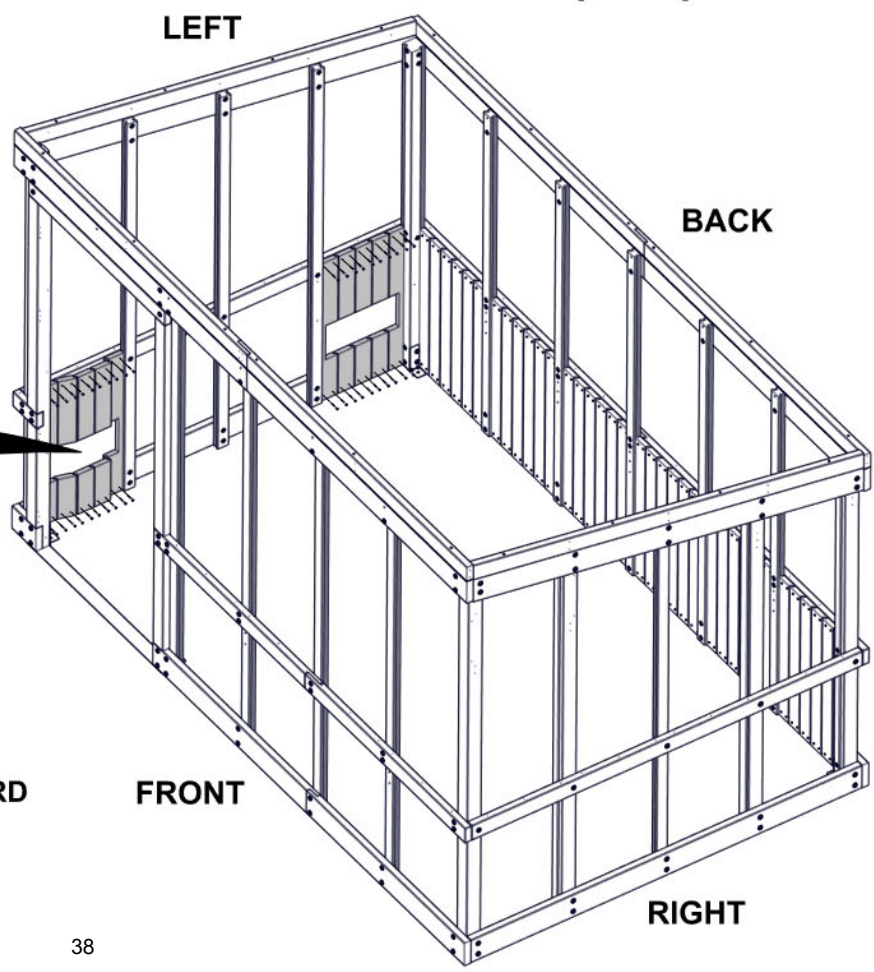
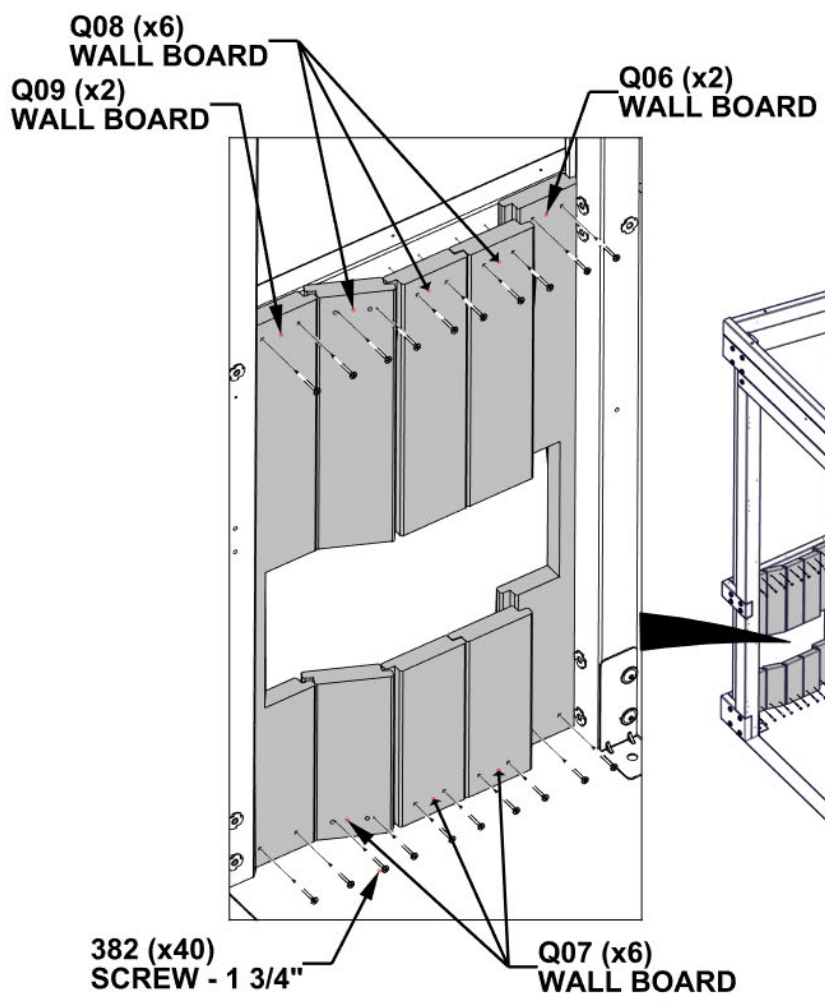
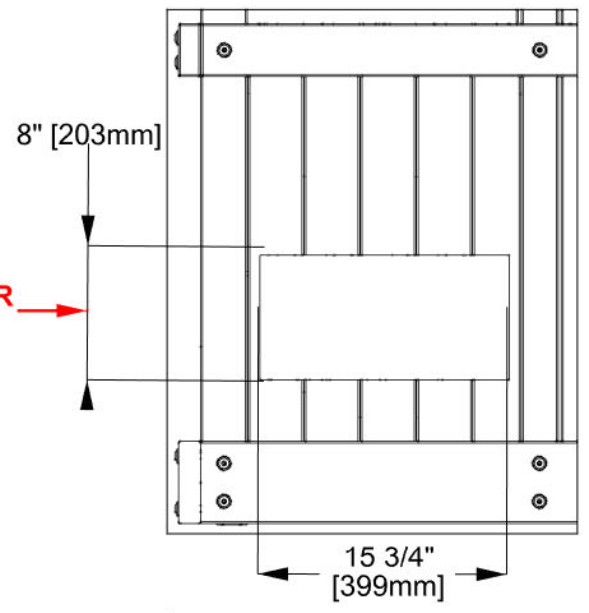

STEP 12B - LEFT WALL BOARDS

Qty	PART NUMBER	DESCRIPTION
40	H100382	SCREW PFH 8 X 1 3/4 BLK



Q04 WALL BOARD - W4L18691
(x2) 15/16"x4 1/16"x32 1/16" (24x103x814)



Q03 WALL BOARD - W4L18690
(x7) 15/16"x4 1/16"x32 1/16" (24x103x814)



Q12 WALL BOARD - W4L18672
(x1) 15/16"x4 1/16"x32 1/16" (24x103x814)

NOTES:
MAKE SURE BOARDS ARE FLUSH WITH RUNNING BOARD
AND EVENLY SPACED BEFORE INSERTING SCREWS.

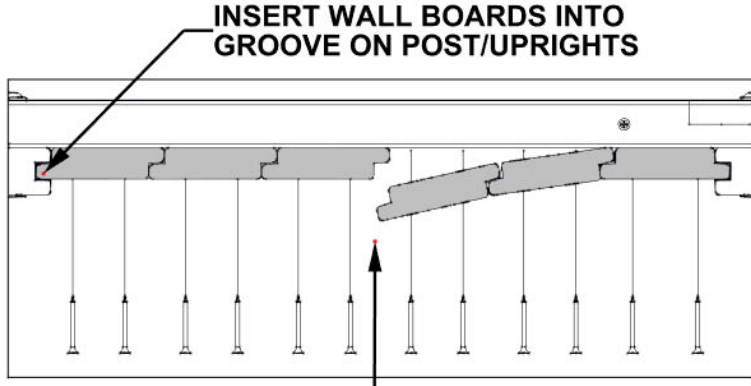

TO GET ALL BOARDS TO PROPERLY SEAT
MAY REQUIRE POSITIONING BOARDS AS
SHOWN AND INSERTING TONGUE INTO GROOVE.

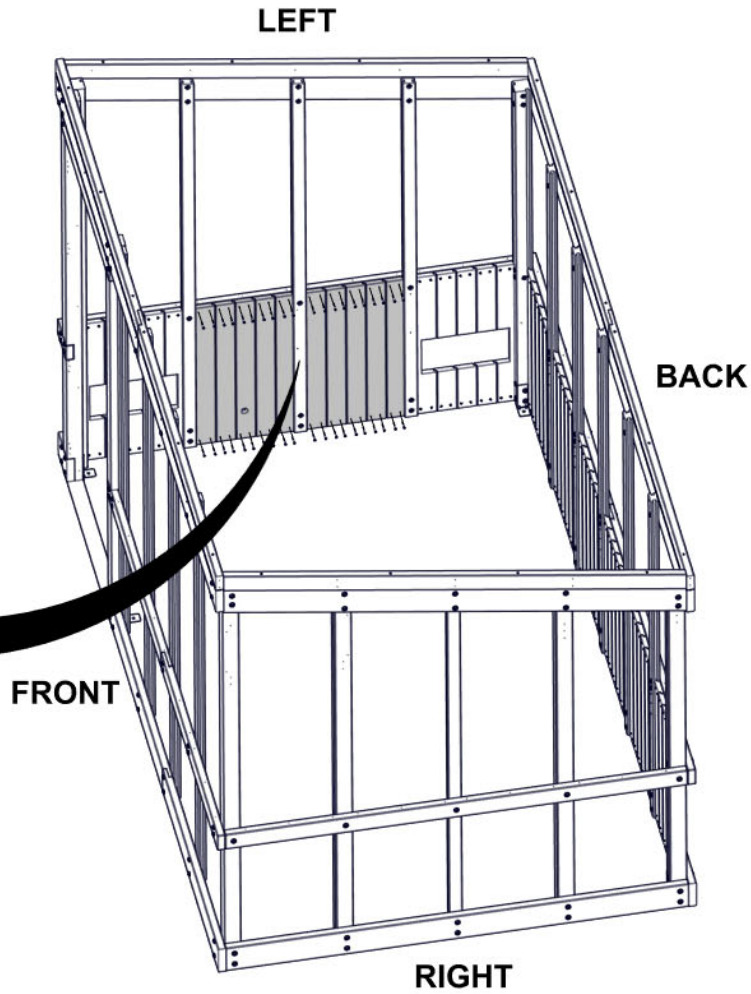
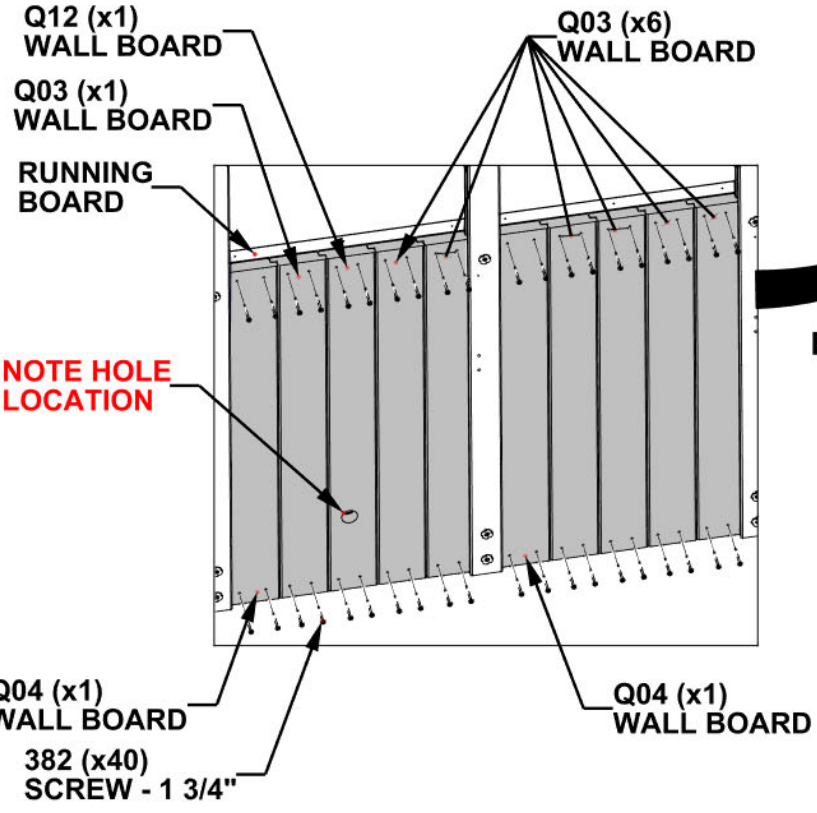

STEP 13A - RIGHT WALL BOARDS

Qty	PART NUMBER	DESCRIPTION
40	H100382	SCREW PFH 8 X 1 3/4 BLK



Q13 WALL BOARD - W4L18701
(x2) 15/16"x3 7/16"x32 1/16" (24x87x814)



Q03 WALL BOARD - W4L18690
(x6) 15/16"x4 1/16"x32 1/16" (24x103x814)



Q14 WALL BOARD - W4L18733
(x2) 15/16"x3 7/16"x32 1/16" (24x87x814)

NOTES:

- MAKE SURE BOARDS ARE FLUSH WITH RUNNING BOARD AND EVENLY SPACED BEFORE INSERTING SCREWS.
- BOARDS WILL BE INSERTED IN THE SAME ORDER FOR OPPOSITE CORNER.

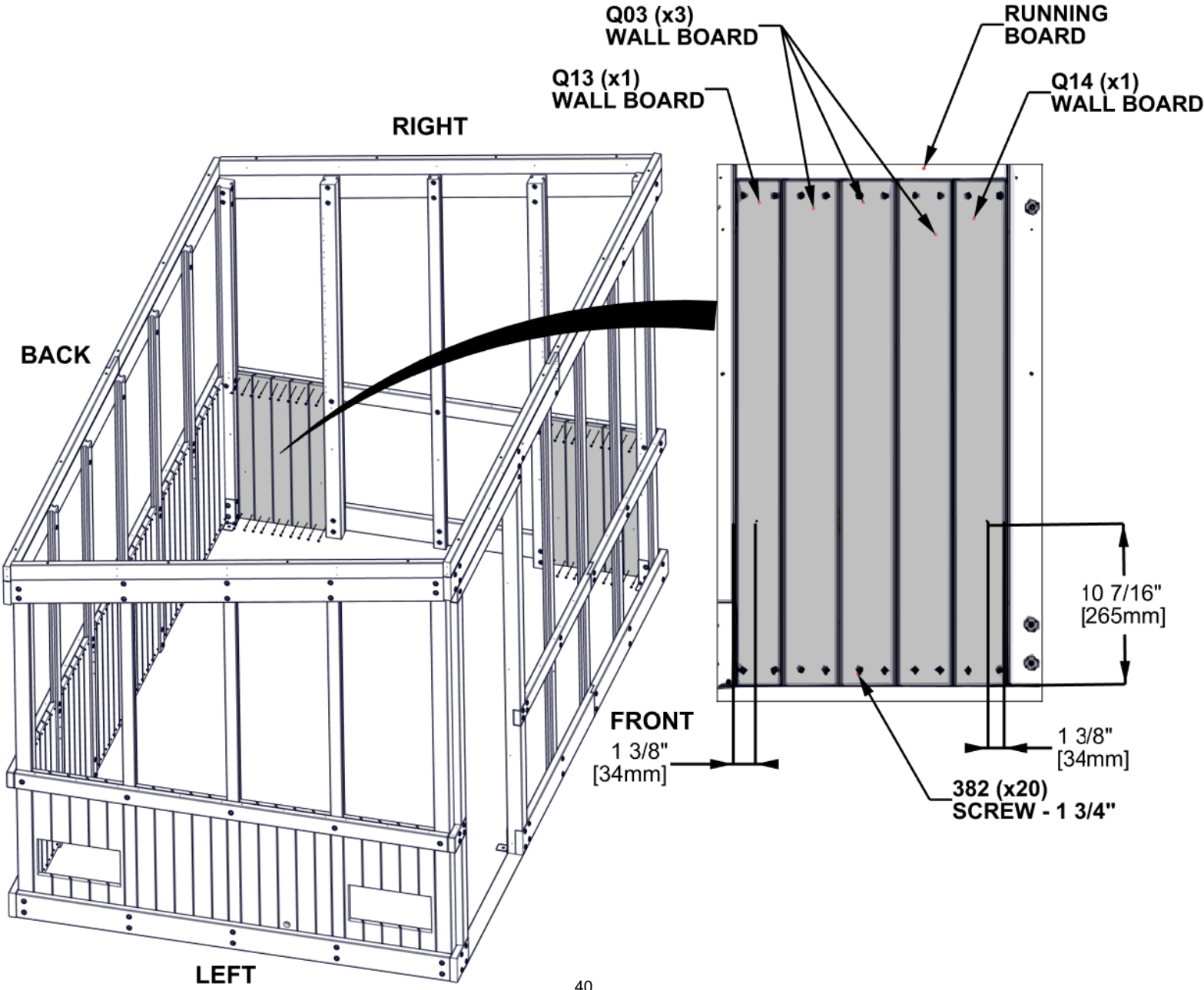

STEP 13B - RIGHT WALL BOARDS

Qty	PART NUMBER	DESCRIPTION
40	H100382	SCREW PFH 8 X 1 3/4 BLK



Q03 WALL BOARD - W4L18690
(x8) 15/16"x4 1/16"x32 1/16" (24x103x814)



Q05 WALL BOARD - W4L18692
(x1) 15/16"x3 3/4"x32 1/16" (24x95x814)



Q11 WALL BOARD - W4L18800
(x1) 15/16"x3 3/4"x32 1/16" (24x95x814)

NOTES:
MAKE SURE BOARDS ARE FLUSH WITH RUNNING BOARD
AND EVENLY SPACED BEFORE INSERTING SCREWS.

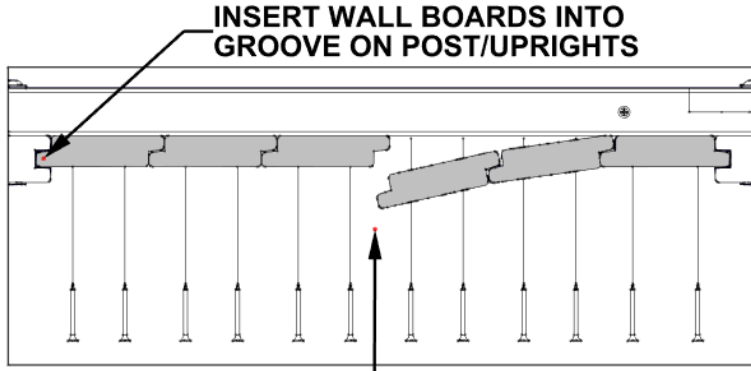

TO GET ALL BOARDS TO PROPERLY SEAT
MAY REQUIRE POSITIONING BOARDS AS
SHOWN AND INSERTING TONGUE INTO GROOVE.

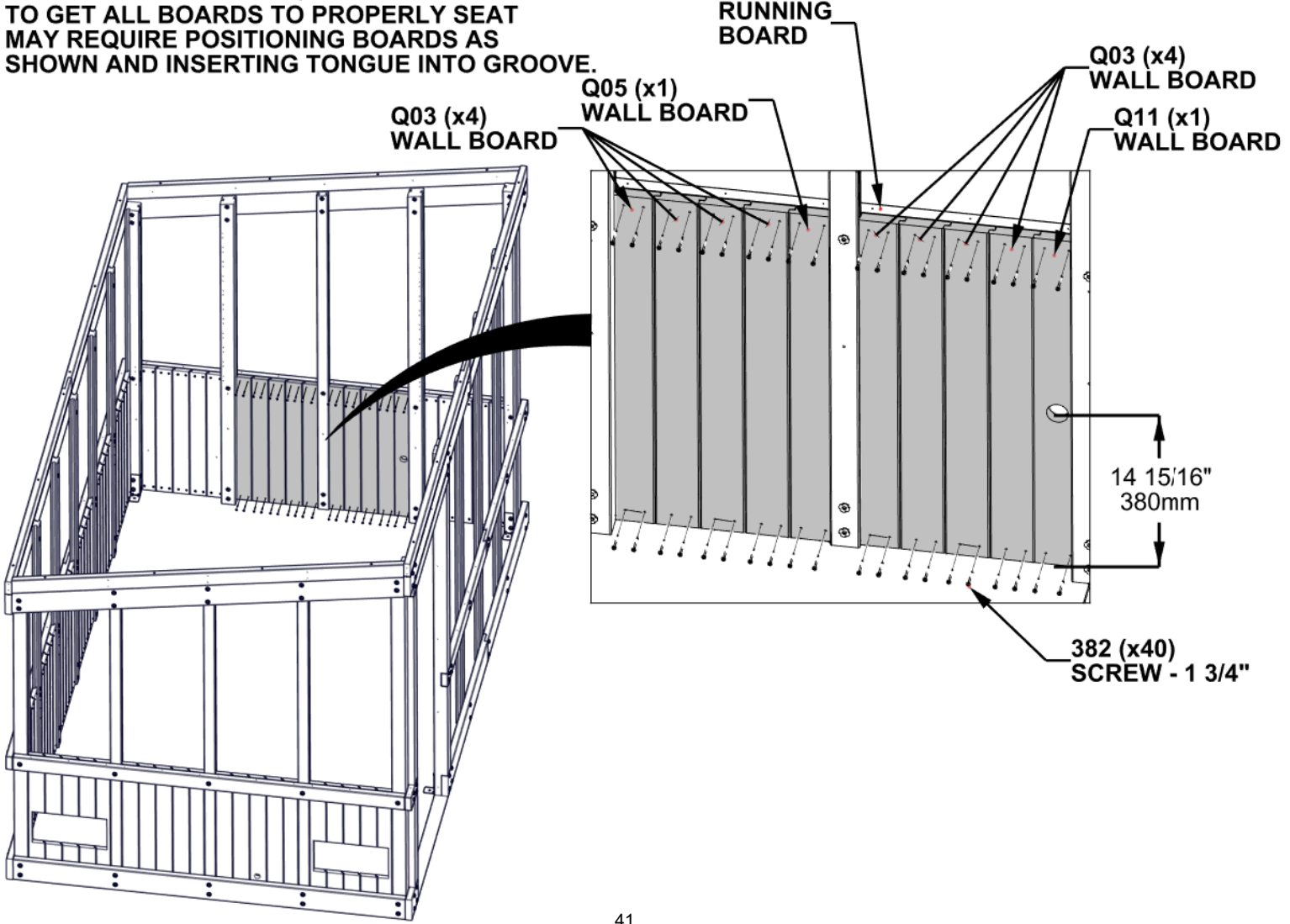

STEP 14 - FRONT WALL BOARDS

Qty	PART NUMBER	DESCRIPTION
96	H100382	SCREW PFH 8 X 1 3/4 BLK



Q01 WALL BOARD - W4L18688
(x20) 15/16"x4"x32 1/16" (24x98x814)



Q02 WALL BOARD - W4L18689
(x4) 15/16"x3 15/16"x32 1/16" (24x100x814)

NOTES:

- MAKE SURE BOARDS ARE FLUSH WITH RUNNING BOARD AND EVENLY SPACED BEFORE INSERTING SCREWS.
- BOARDS WILL BE INSERTED IN THE SAME ORDER FOR ALL FOUR PANELS.

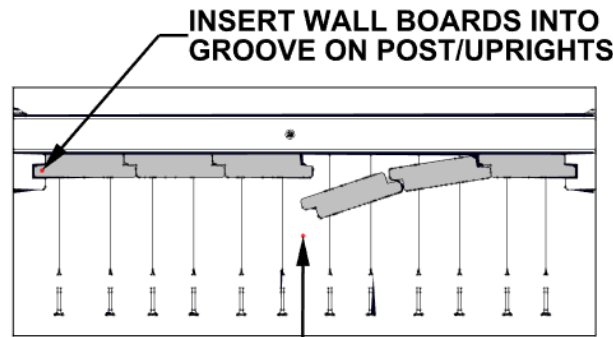

TO GET ALL BOARDS TO PROPERLY SEAT MAY REQUIRE POSITIONING BOARDS AS SHOWN AND INSERTING TONGUE INTO GROOVE.

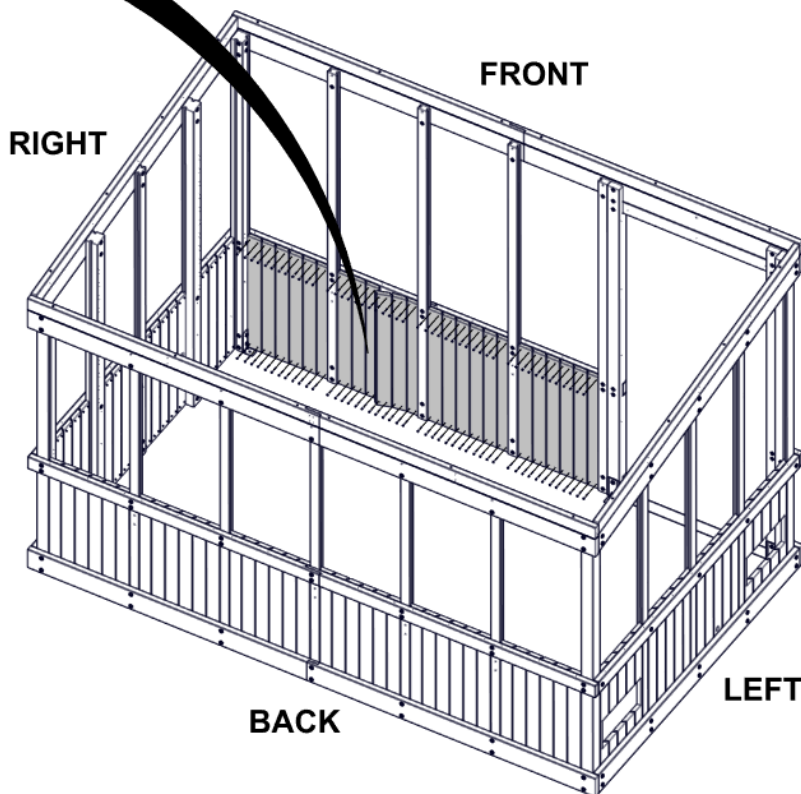
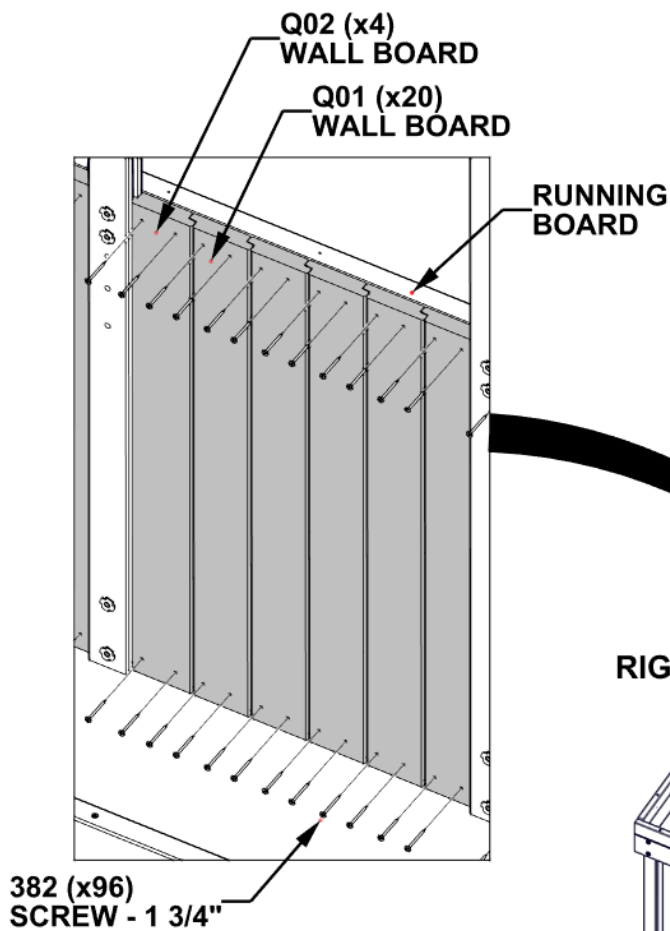

STEP 15 - BACK LEDGE BOARDS

Qty	PART NUMBER	DESCRIPTION
18	H100391	SCREW PFH 8 X 2 BLK



E12 LEDGE BOARD - W4L18718
(x1) 1 7/16"x3 3/8"x26 1/4" (36x86x666)

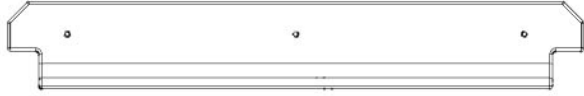

E01 LEDGE BOARD - W4L18693
(x4) 1 7/16"x3 3/8"x22 7/16" (36x86x570)



E19 LEDGE BOARD - W4L18725
(x1) 1 7/16"x3 3/8"x26 1/4" (36x86x666)

NOTES:

- PLACE WINDOW LEDGE BOARDS ON TOP OF WALL UNTIL SNUG AGAINST THE POST.
- ALIGN PILOT HOLES; ATTACH AS SHOWN.

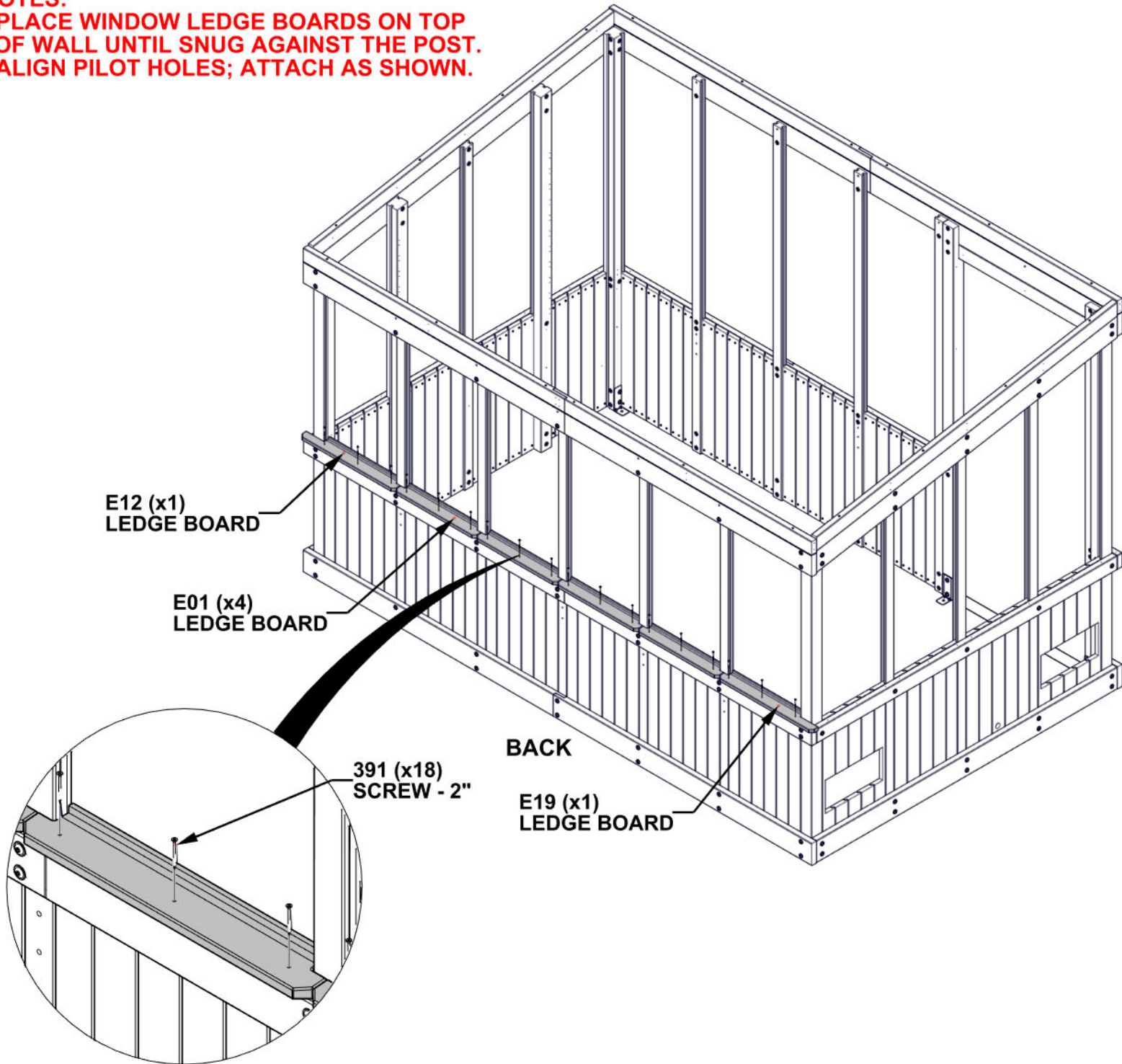

STEP 16 - LEFT LEDGE BOARDS

Qty	PART NUMBER	DESCRIPTION
12	H100391	SCREW PFH 8 X 2 BLK



E18 LEDGE BOARD - W4L18724
(x1) 1 7/16"x3 3/8"x21 3/4" (36x86x552)



E02 LEDGE BOARD - W4L18694
(x2) 1 7/16"x3 3/8"x19 15/16" (36x86x507)

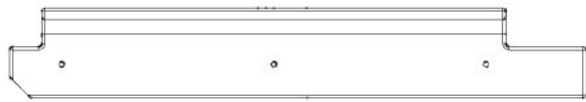

E17 LEDGE BOARD - W4L18723
(x1) 1 7/16"x3 3/8"x21 3/4" (36x86x553)

- NOTES:**
- PLACE WINDOW LEDGE BOARDS ON TOP OF WALL UNTIL SNUG AGAINST THE POST.
 - ALIGN PILOT HOLES; ATTACH AS SHOWN.

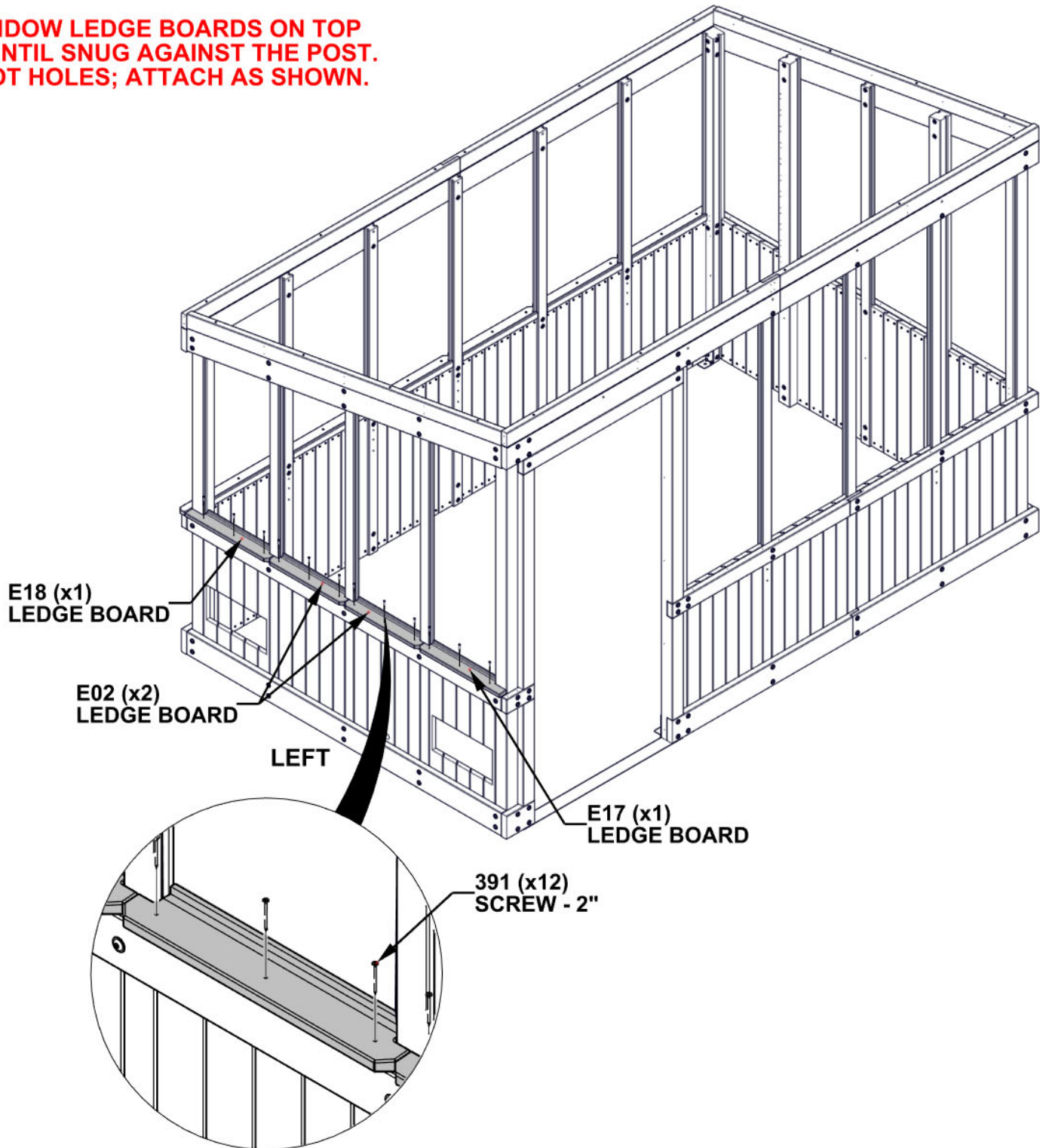

STEP 17 - RIGHT LEDGE BOARDS

Qty	PART NUMBER	DESCRIPTION
12	H100391	SCREW PFH 8 X 2 BLK



E14 LEDGE BOARD - W4L18720
(x1) 15/16"x2 15/16"x21 3/4" (24x74x553)



E13 LEDGE BOARD - W4L18719
(x1) 15/16"x2 15/16"x21 3/4" (24x74x553)

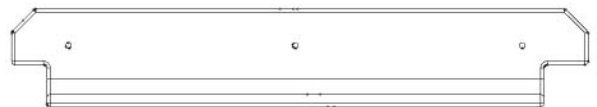

E03 LEDGE BOARD - W4L18695
(x1) 1 7/16"x3 3/8"x19 15/16" (36x86x507)



E04 LEDGE BOARD - W4L18696
(x1) 1 7/16"x3 3/8"x19 15/16" (36x86x507)

- NOTES:**
- PLACE WINDOW LEDGE BOARDS ON TOP OF WALL UNTIL SNUG AGAINST THE POST.
 - ALIGN PILOT HOLES; ATTACH AS SHOWN.

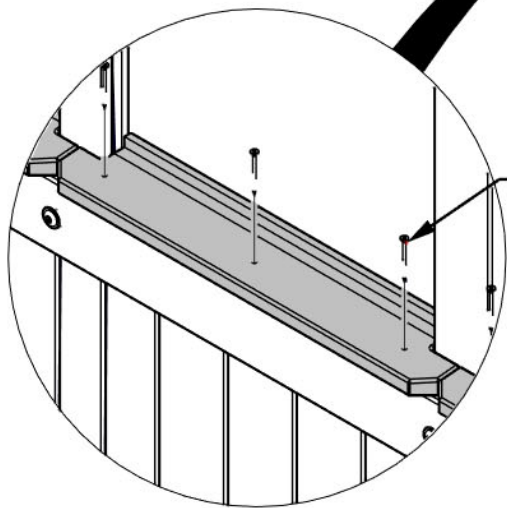
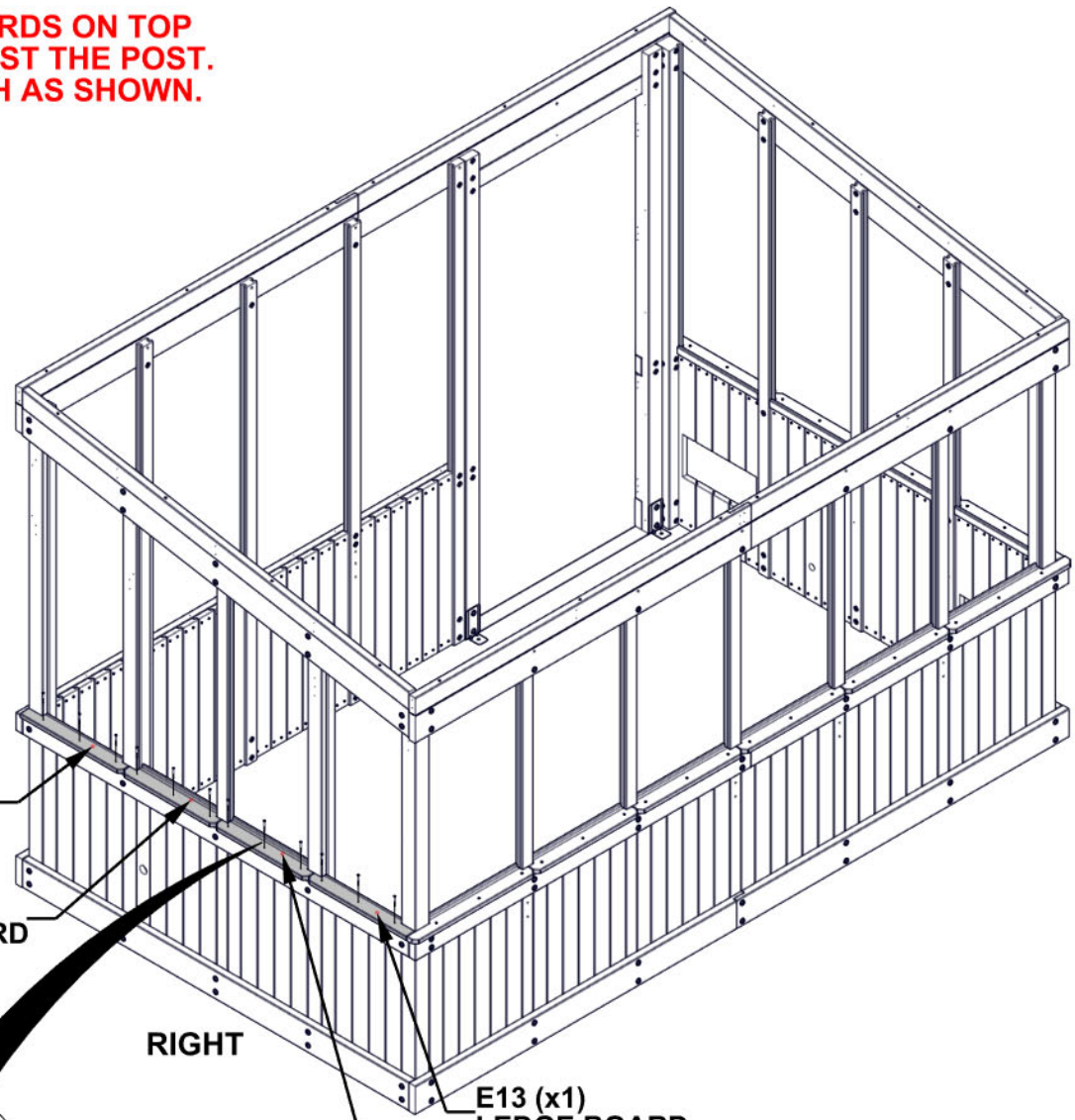

STEP 18 - FRONT LEDGE BOARDS

Qty	PART NUMBER	DESCRIPTION
14	H100391	SCREW PFH 8 X 2 BLK



E16 LEDGE BOARD - W4L18722
(x1) 1 7/16"x3 3/8"x23 5/8" (36x86x600)



E15 LEDGE BOARD - W4L18721
(x1) 1 7/16"x3 3/8"x26 1/4" (36x86x666)



E01 LEDGE BOARD - W4L18693
(x2) 1 7/16"x3 3/8"x22 7/16" (36x86x570)



J12 LEDGE BOARD - W4L18816
(x1) 15/16"x1 15/16"x4 15/16" (24x50x126)

- NOTES:**
- PLACE WINDOW LEDGE BOARDS ON TOP OF WALL UNTIL SNUG AGAINST THE POST.
 - ALIGN PILOT HOLES; ATTACH AS SHOWN.

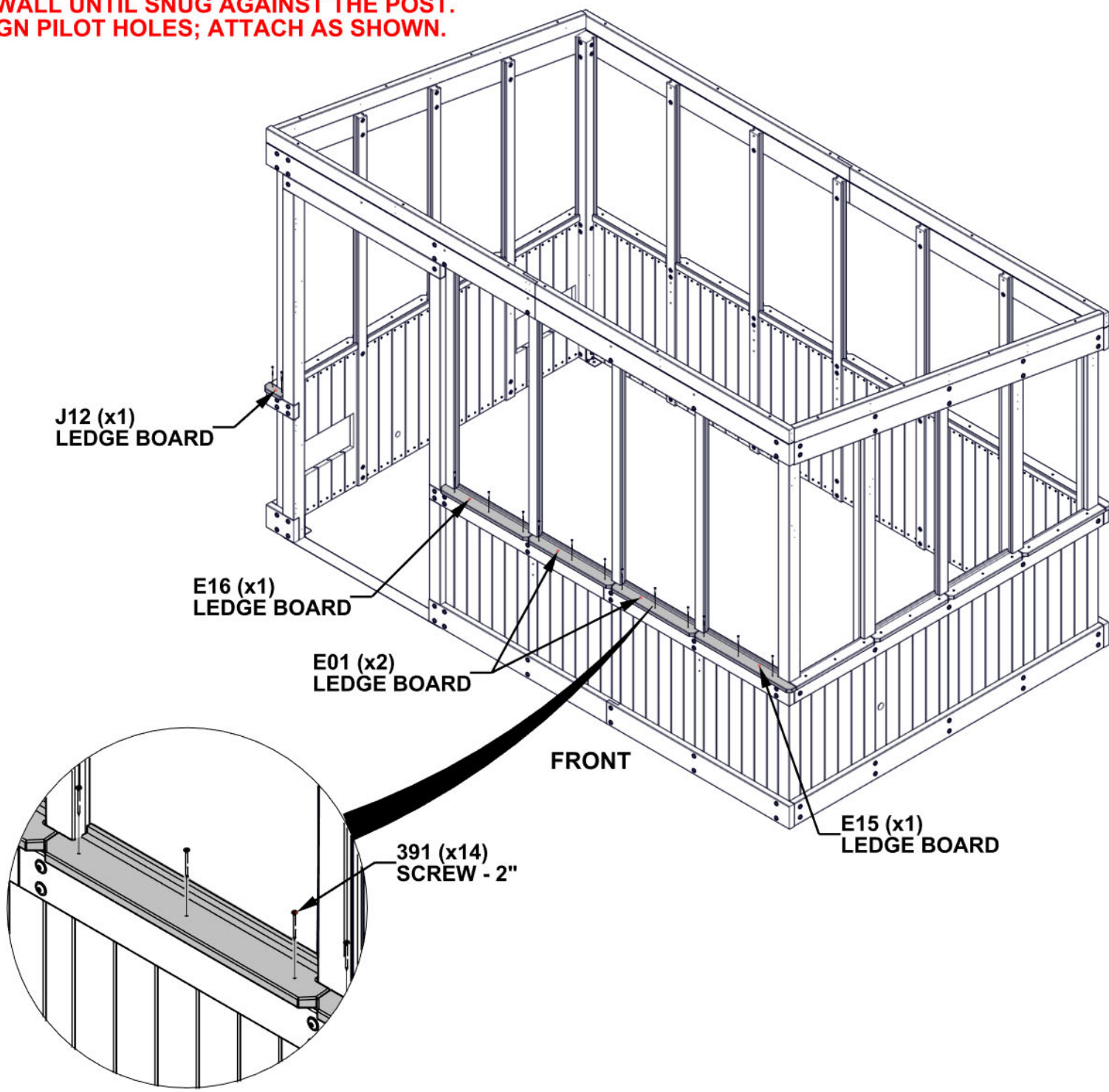

STEP 19A - LOUVERS

Qty	PART NUMBER	DESCRIPTION
12	H100797	SCREW PWH 8 X 1 BLK

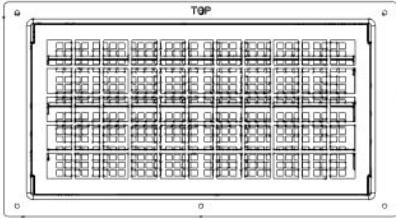

A6P00730 LOUVER
(x2)

NOTES:

- SLIDE LOUVER INTO OPENING UNTIL FLANGE ON LOUVER CONTACTS WALL BOARDS.
- CENTER LOUVER IN OPENING.
- USE LOUVER FLANGE AS A GUIDE AND AN 1/8" [3mm] DRILL BIT TO CREATE PILOT HOLES INTO WALL PANEL. DO NOT DRILL THROUGH BOARD.
- ATTACH AS SHOWN.

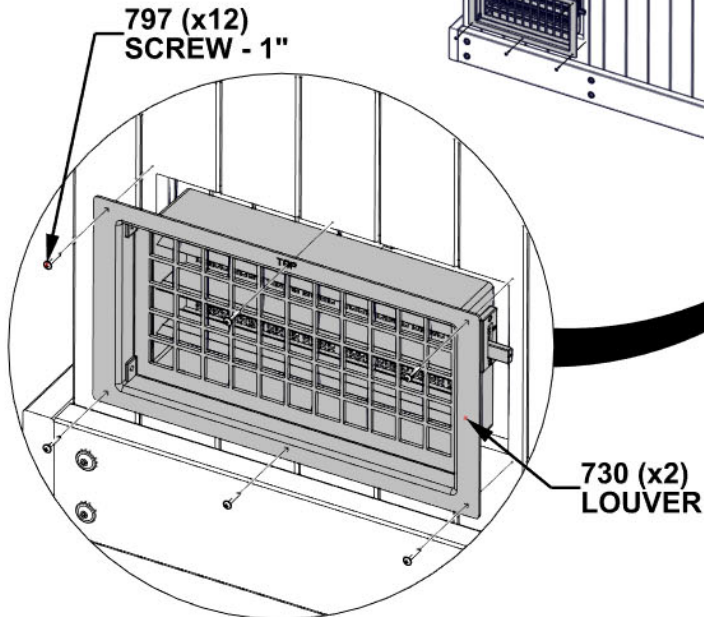
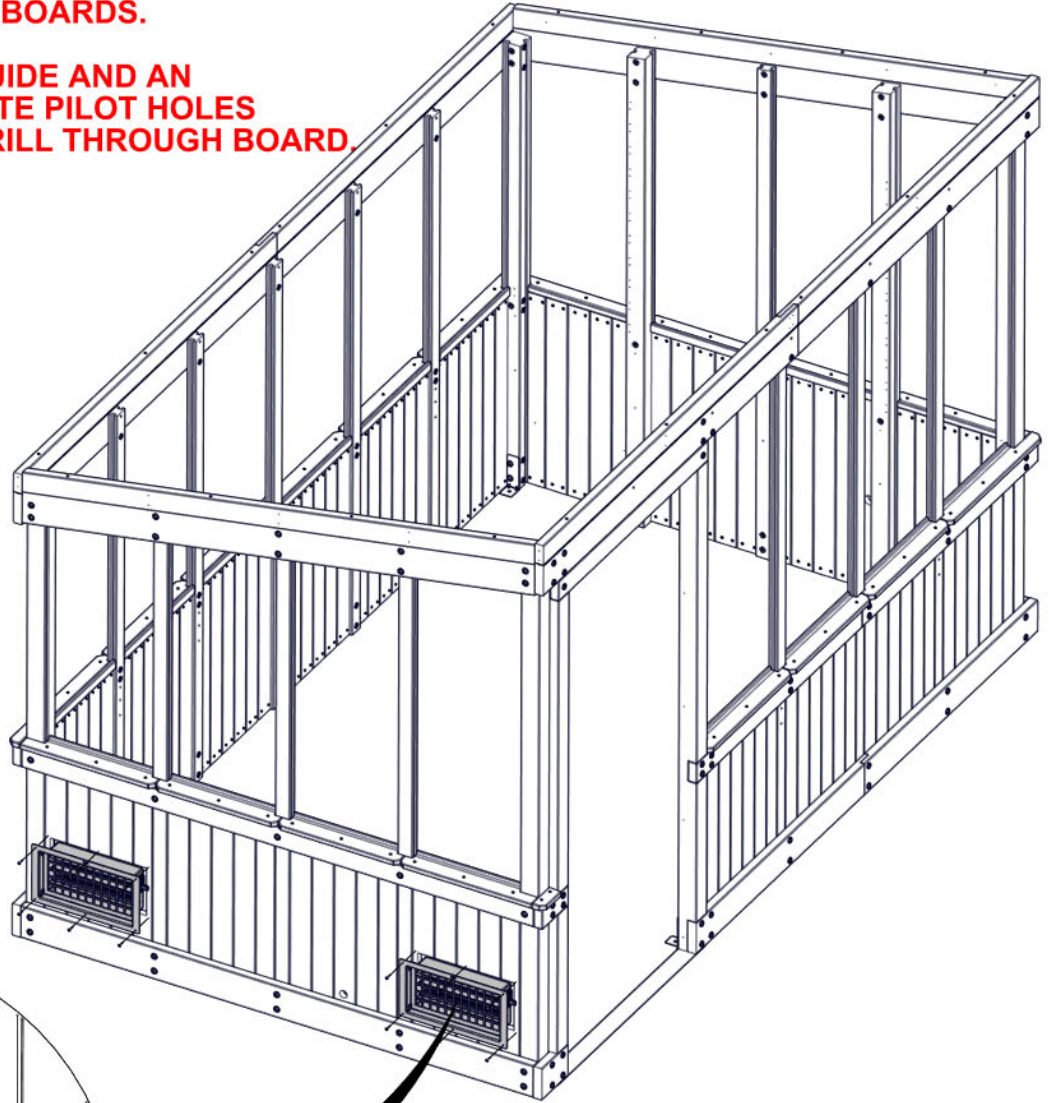

STEP 19B - LOUVERS

Qty	PART NUMBER	DESCRIPTION
32	H100200	SCREW PFH 8 X 1 1/2 BLK



J11 LOUVER TRIM - W4L18814
(x4) 15/16"x2 3/8"x17 1/2" (24x60x445)



S01 LOUVER TRIM - W4L18815
(x4) 15/16"x15/16"x7 15/16" (24x24x202)

- NOTES:**
- PLACE LOUVER TRIM BOARDS AROUND LOUVER AS SHOWN.
 - LOUVER TRIM SHOULD BE SNUG AGAINST THE LOUVER.
 - USE LOUVER TRIM HOLES AS GUIDE AND USE AN 1/8 DRILL BIT TO CREATE PILOT HOLES IN WALL PANEL.

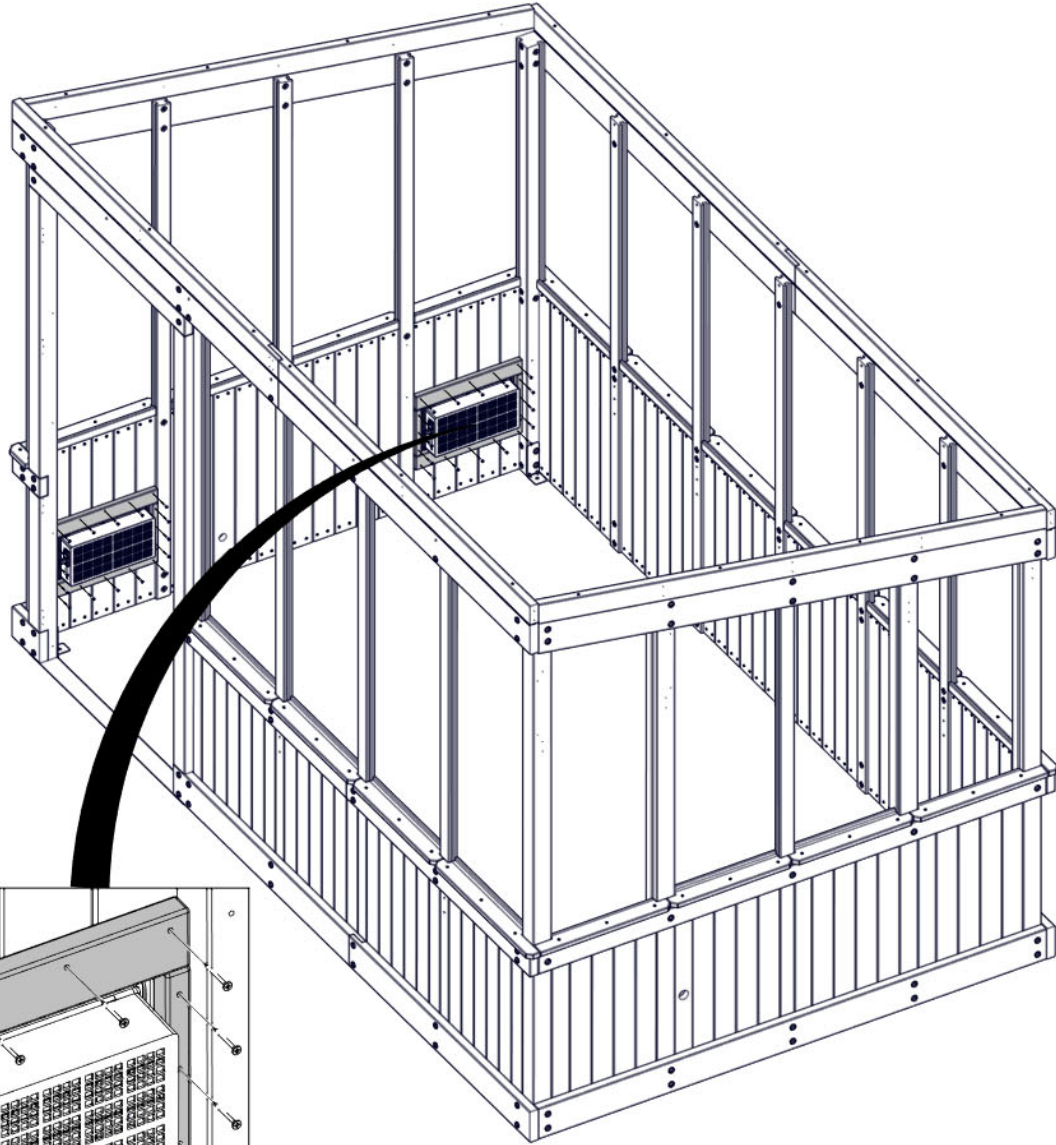

J11 (x4)
LOUVER TRIM

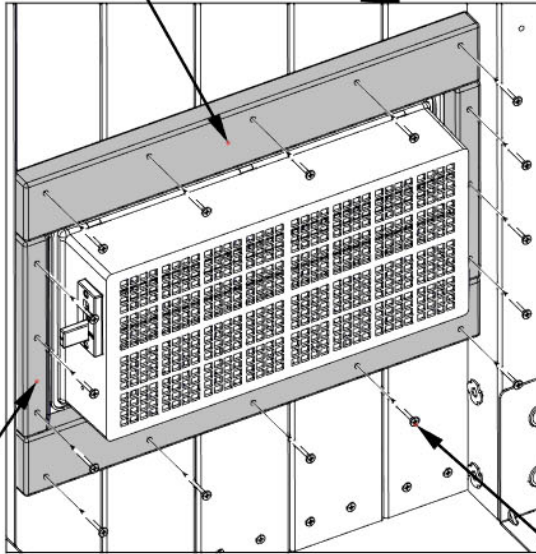

S01 (x4)
LOUVER TRIM

200 (x32)
SCREW - 1 1/2"

STEP 20 - RAFTER BRACKETS

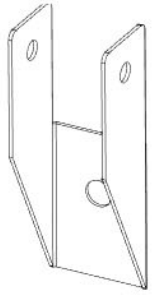

A4M02093 RAFTER BRACKET
(x10)

Qty	PART NUMBER	DESCRIPTION
9	H100193	NUT BARREL WH 5/16 X 1 1/2 BLK
10	H100198	WASHER LOCK EXT 8X19 BLK
9	H100457	BOLT WH 5/16 X 2 BLK
1	H100459	BOLT WH 5/16 X 1 1/4 BLK
1	H100469	NUT BARREL WH 5/16 X 5/8 BLK

NOTES:
HAND TIGHTEN ONLY

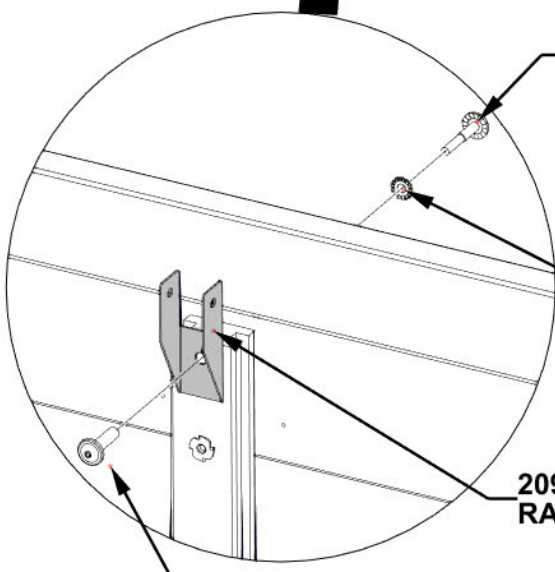
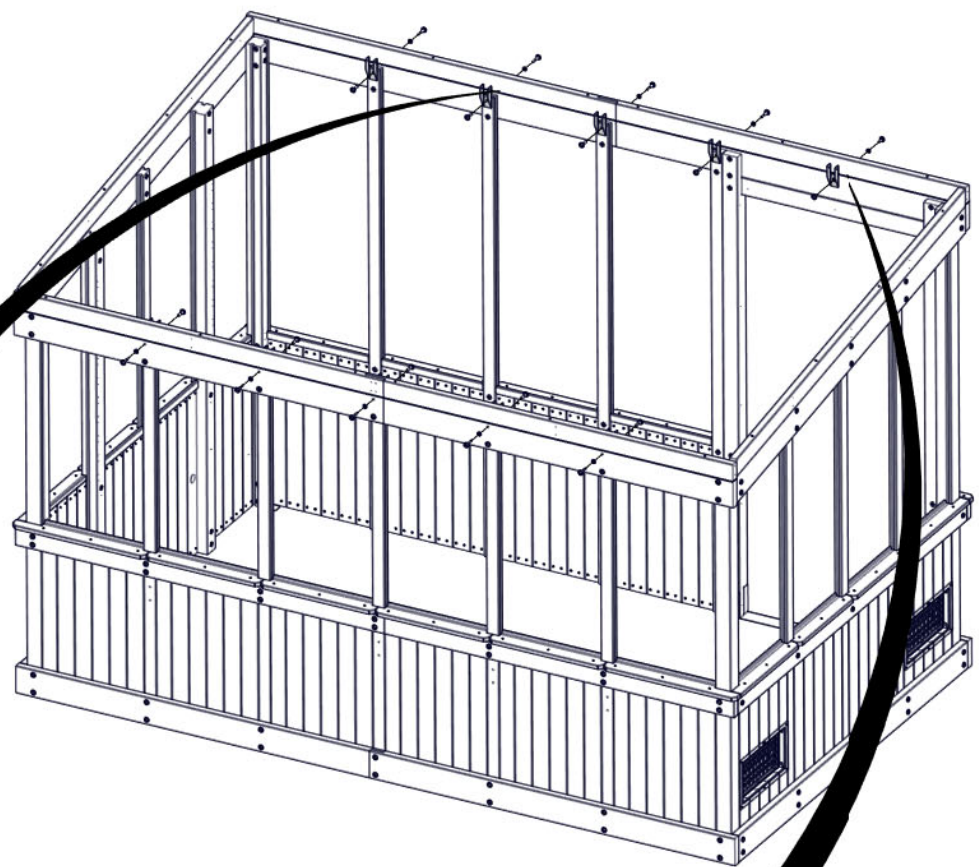

457 (x9)
BOLT - 2"

198 (x10)
WASHER - 8x19

2093 (x10)
RAFTER BRACKET

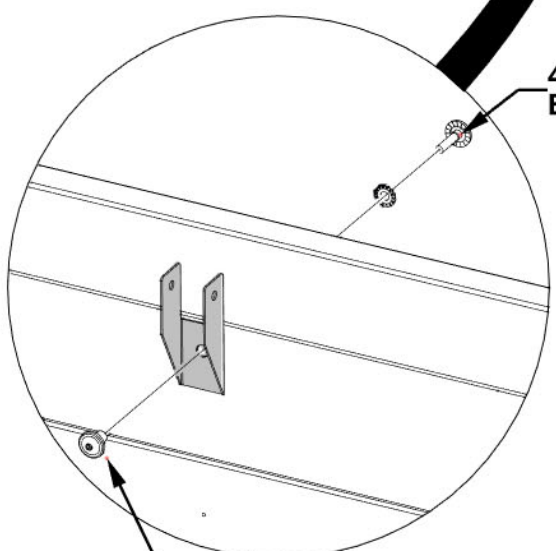

459 (x1)
BOLT - 1 1/4"

469 (x1)
BARREL NUT - 5/8"

193 (x9)
BARREL NUT - 1 1/2"

STEP 21 - RIGHT TABLE

Qty	PART NUMBER	DESCRIPTION
6	H100201	SCREW PFH 8 X 2 1/2 BLK
12	H100387	SCREW PFH 8 X 1 1/4 BLK

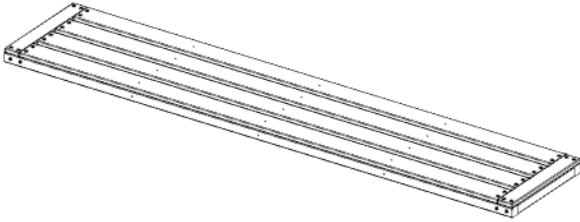

F08 TABLE FRAME BOARD - W4L18748
(x3) 1 7/16"x1 7/16"x13 1/8" (36x36x333)

TP01 RIGHT TABLE ASSEMBLY - W2A03993
(x1) 2 1/16"x16"x80 7/16" (52x407x2043)

1. FLIP TABLE UPSIDE DOWN & INSERT BOARDS & HARDWARE AS SHOWN.

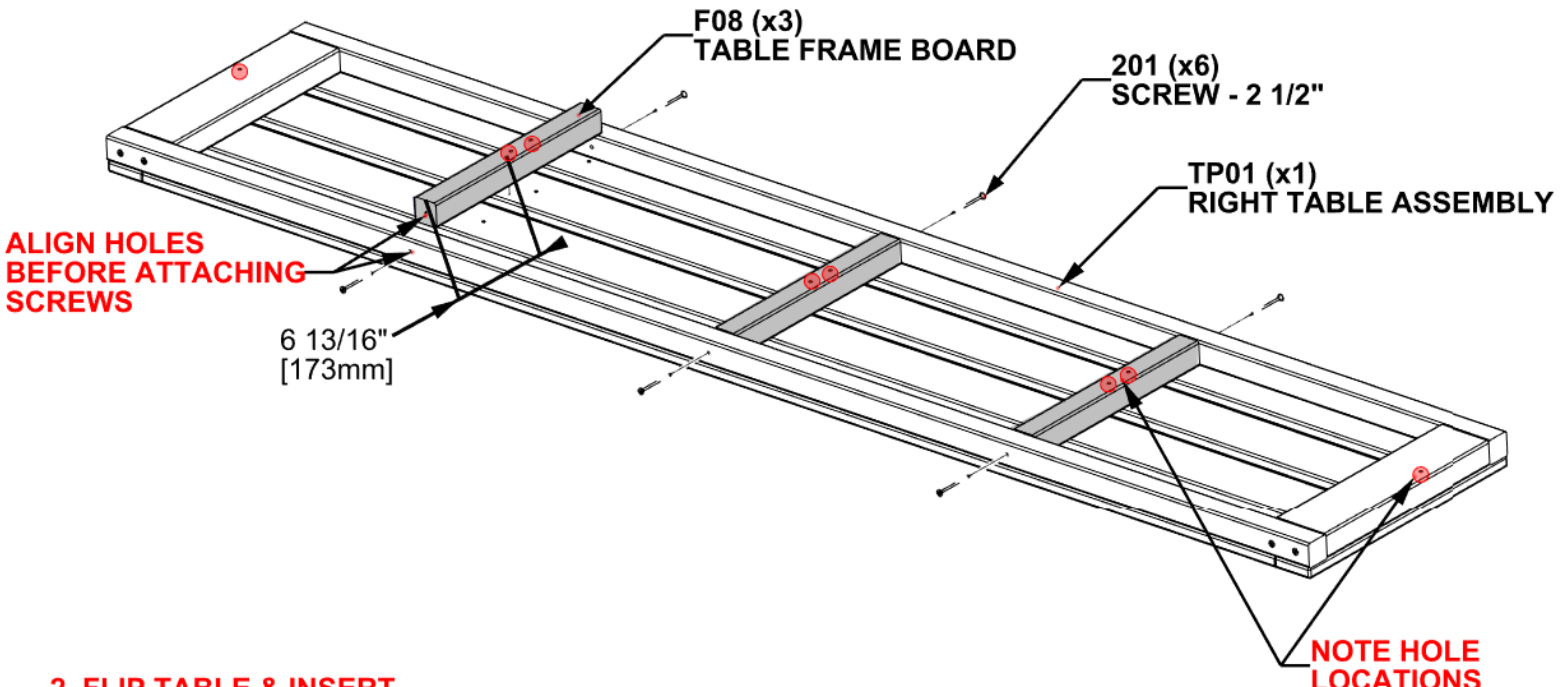

2. FLIP TABLE & INSERT HARDWARE AS SHOWN.

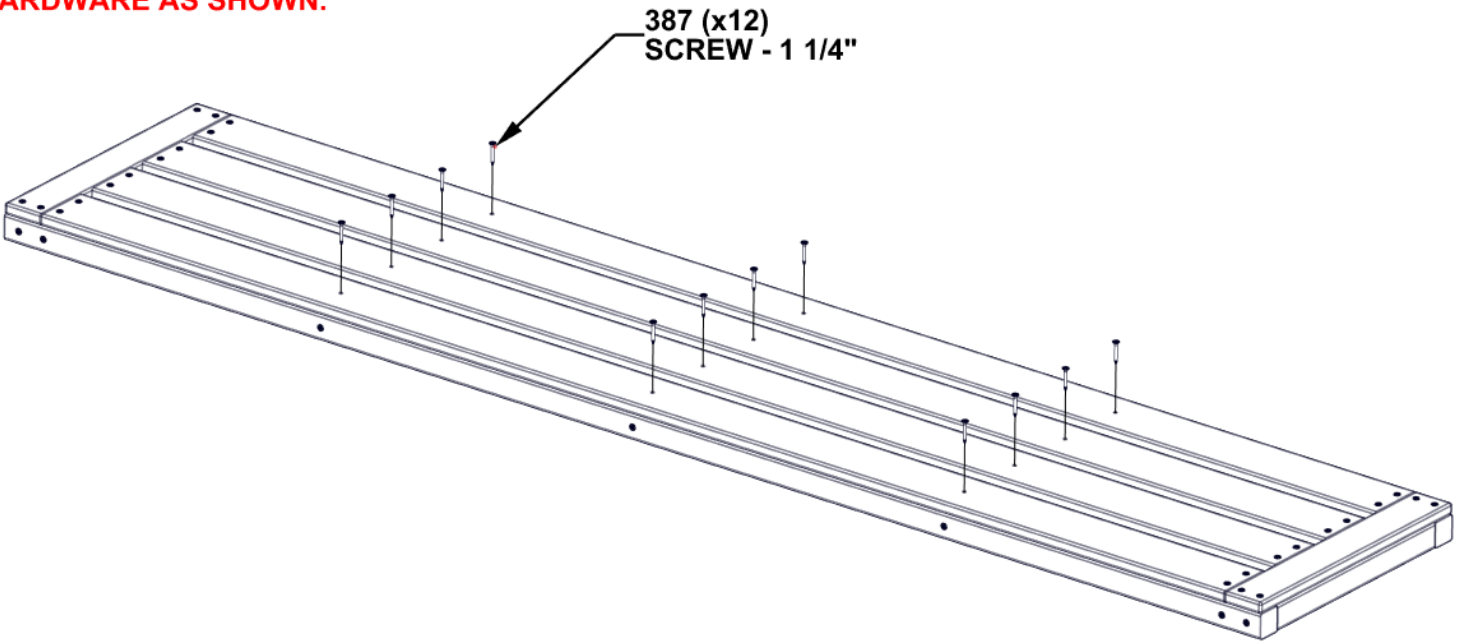

**SET STEP 21 ASSEMBLY
TO THE SIDE**

STEP 22 - RIGHT TABLE

Qty	PART NUMBER	DESCRIPTION
4	H100483	SCREW PFH 8 X 2 1/4 BLK



P12 CLEAT - W4L18796
 (x1) 1 7/16"x1 7/16"x80 7/16" (36x36x2043)

NOTES:
ALIGN BOARD WITH PILOT HOLES
BEFORE ATTACHING SCREWS.

RIGHT

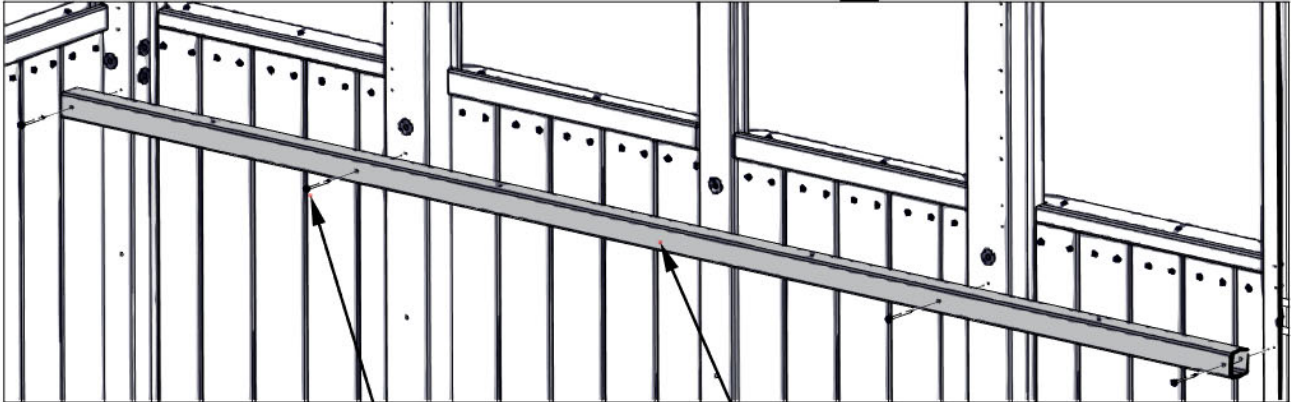
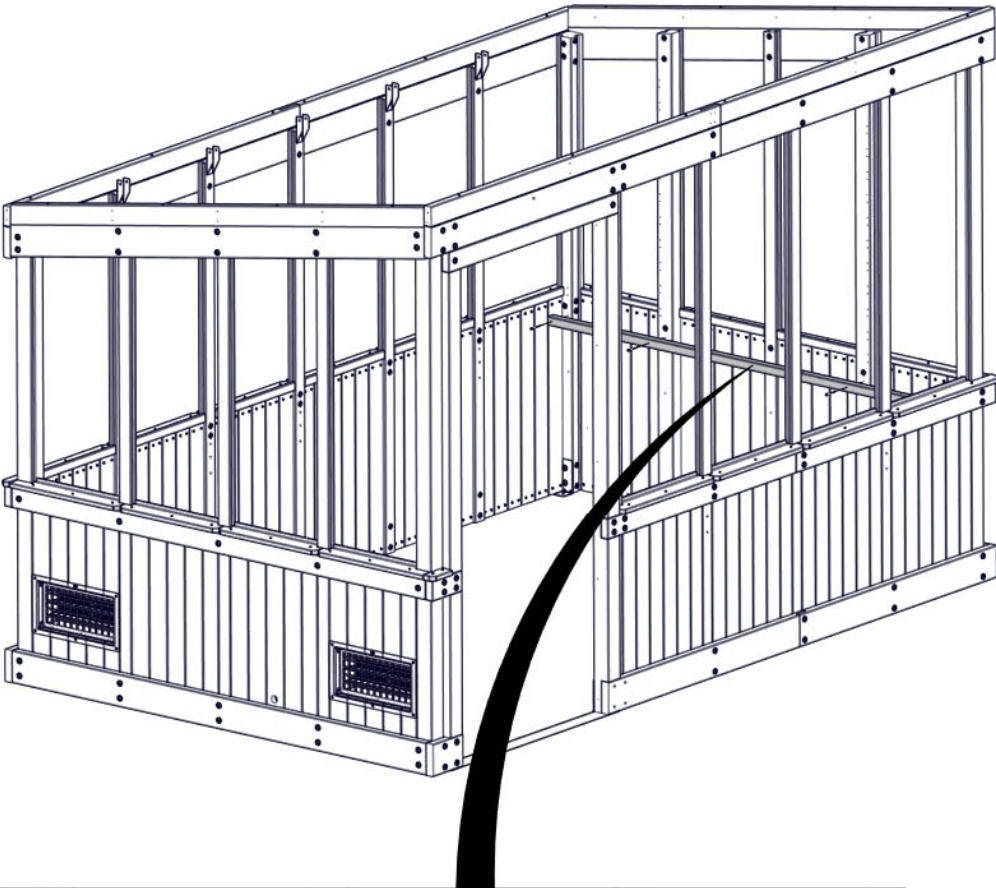

483 (x4)
 SCREW - 2 1/4" P12 (x1)
 CLEAT

STEP 23 - RIGHT TABLE

Qty	PART NUMBER	DESCRIPTION
5	H100405	WASHER LOCK EXT 6X15 BLK
5	H100792	LAG SCREW WH 1/4 X 3 BLK



F09 DIAGONAL BRACE - W4L18749
 (x5) 1 7/16"x2 3/8"x15 3/16" (36x60x385)

- NOTES:**
- HAND TIGHTEN ONLY
 - ALIGN BRACE WITH PILOT HOLES BEFORE ATTACHING SCREWS.

RIGHT

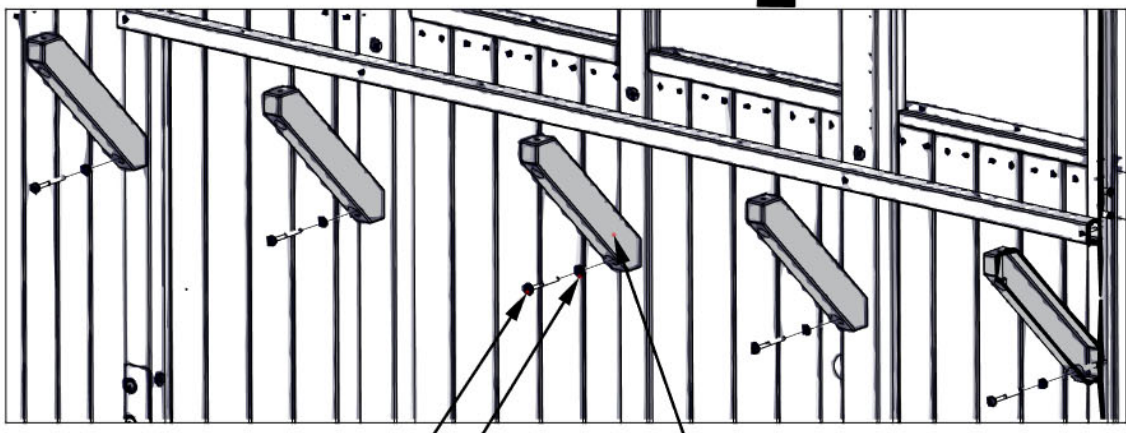
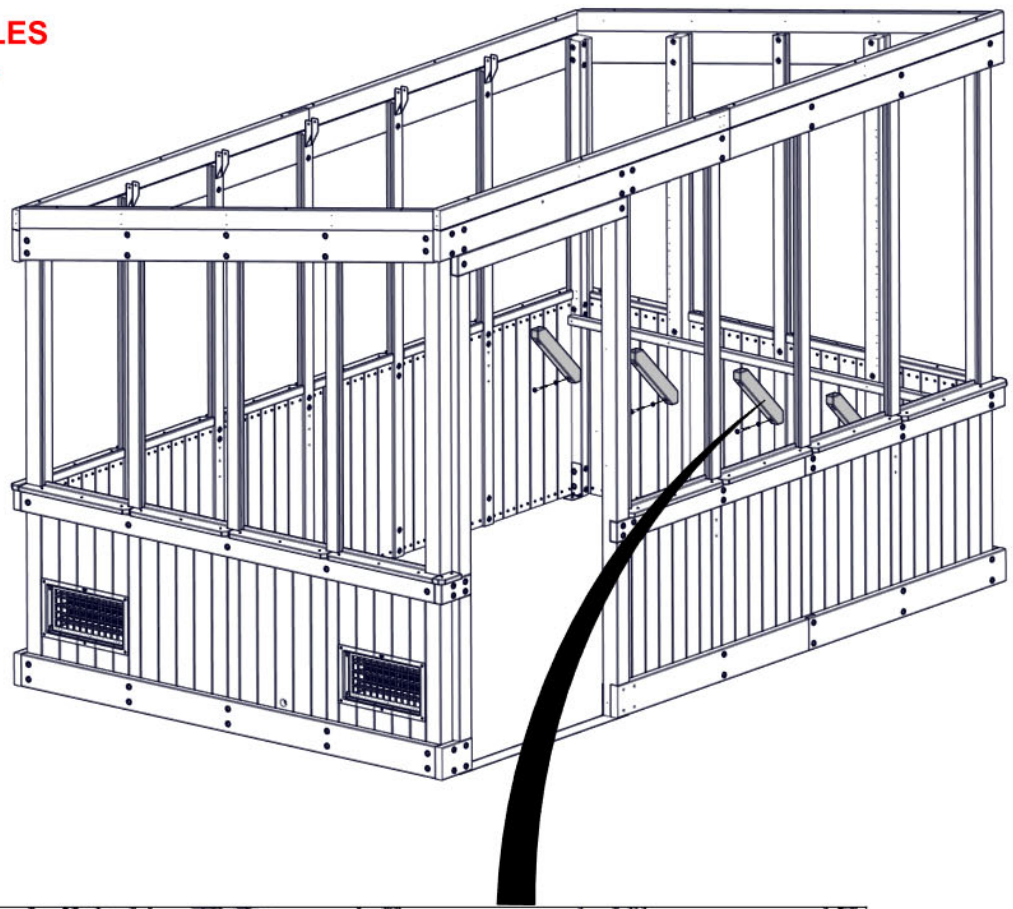

792 (x5)
 LAG SCREW - 3"
 405 (x5)
 WASHER - 6x15

F09 (x5)
 DIAGONAL BRACE

STEP 24 - RIGHT TABLE

Qty	PART NUMBER	DESCRIPTION
5	H100405	WASHER LOCK EXT 6X15 BLK
5	H100456	LAG SCREW WH 1/4 X 2 1/2 BLK

- NOTES:**
- ALIGN PILOT HOLES IN TABLE WITH BRACES AND ATTACH AS SHOWN.
 - IMPORTANT! TIGHTEN ALL HARDWARE FOR TABLE.

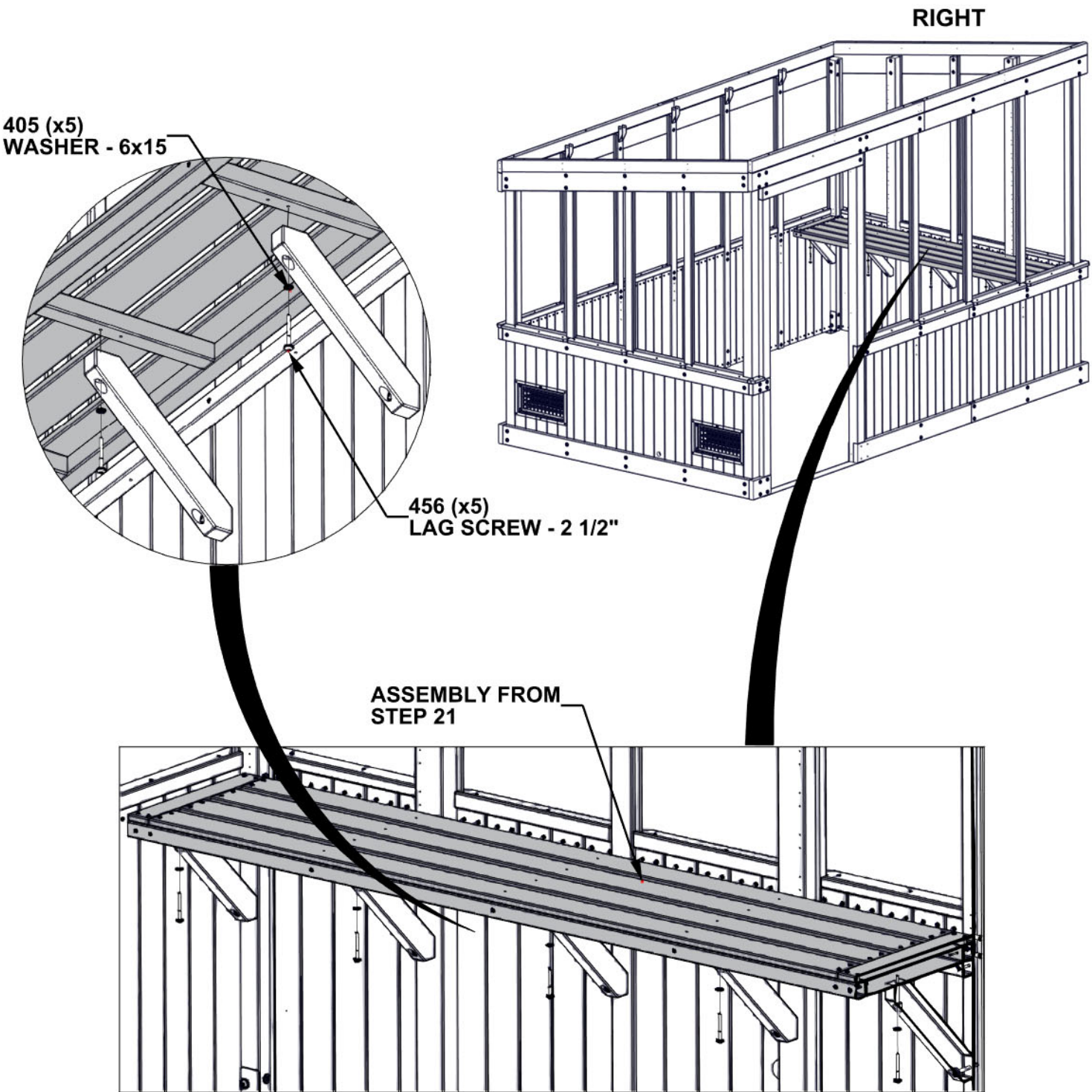

STEP 25 - RIGHT TABLE

Qty	PART NUMBER	DESCRIPTION
4	H100483	SCREW PFH 8 X 2 1/4 BLK

- NOTES:**
- USE AN 1/8" [3mm] DRILL BIT TO CREATE PILOT HOLES IN CLEAT.
 - DO NOT DRILL THROUGH THE FIRST BOARD OF TABLE.

RIGHT

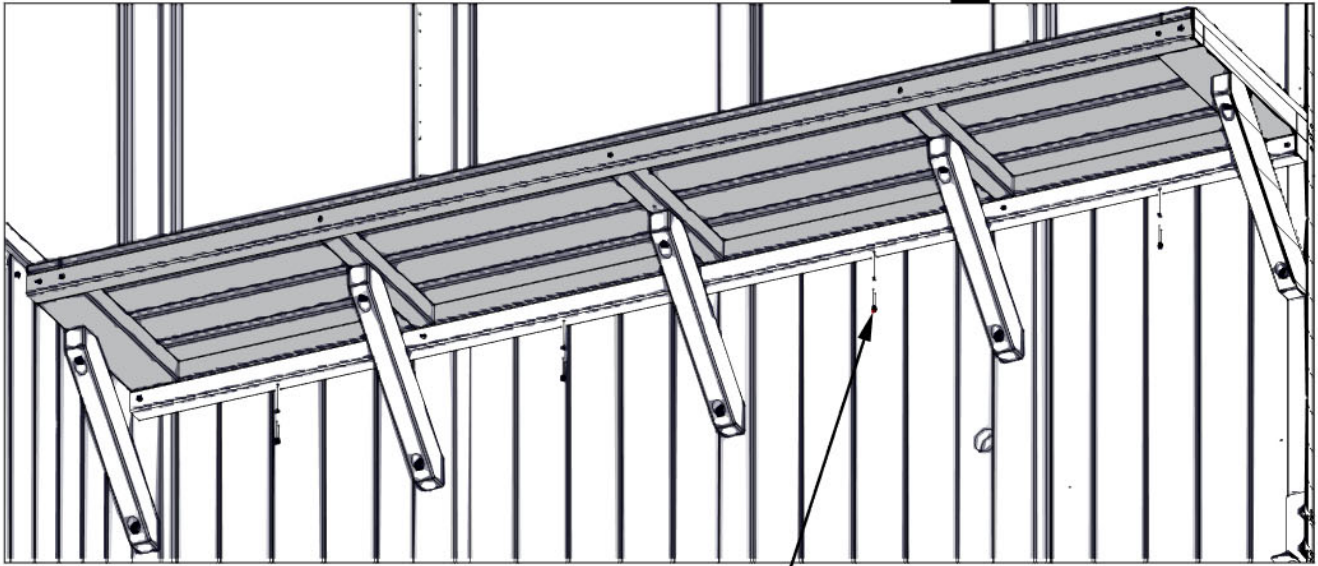
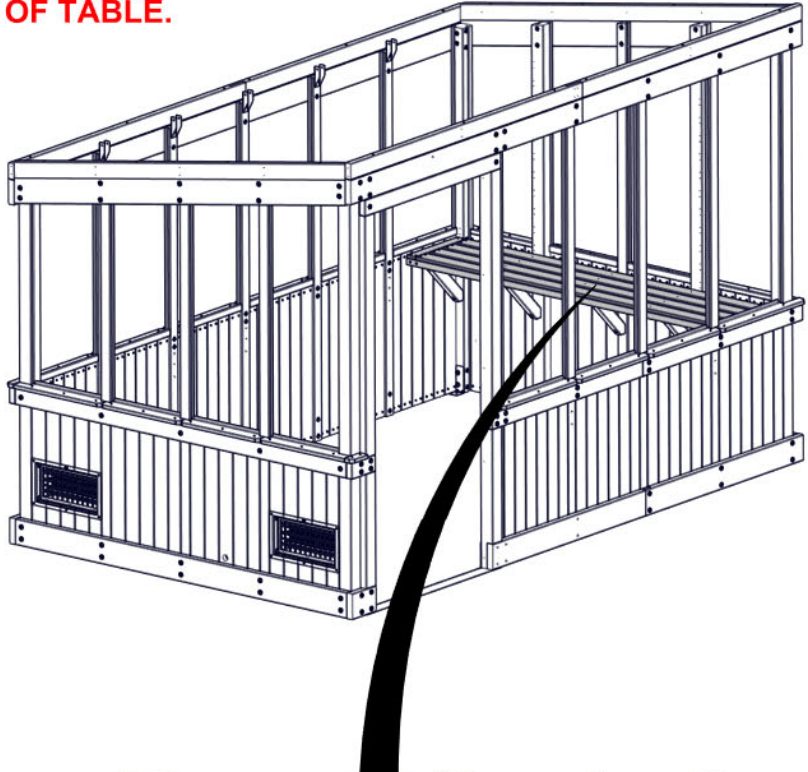

483 (x4)
SCREW - 2 1/4"

STEP 26 - RIGHT TABLE

Qty	PART NUMBER	DESCRIPTION
5	H100200	SCREW PFH 8 X 1 1/2 BLK



M05 TABLE TRIM - W4L18806
 (x1) 5/8"x3 3/8"x80 7/16" (16x86x2043)

NOTES:
 • USE M05 BOARD AS A GUIDE AND AN 1/8" [3mm] DRILL BIT TO CREATE PILOT HOLES IN TABLE.

RIGHT

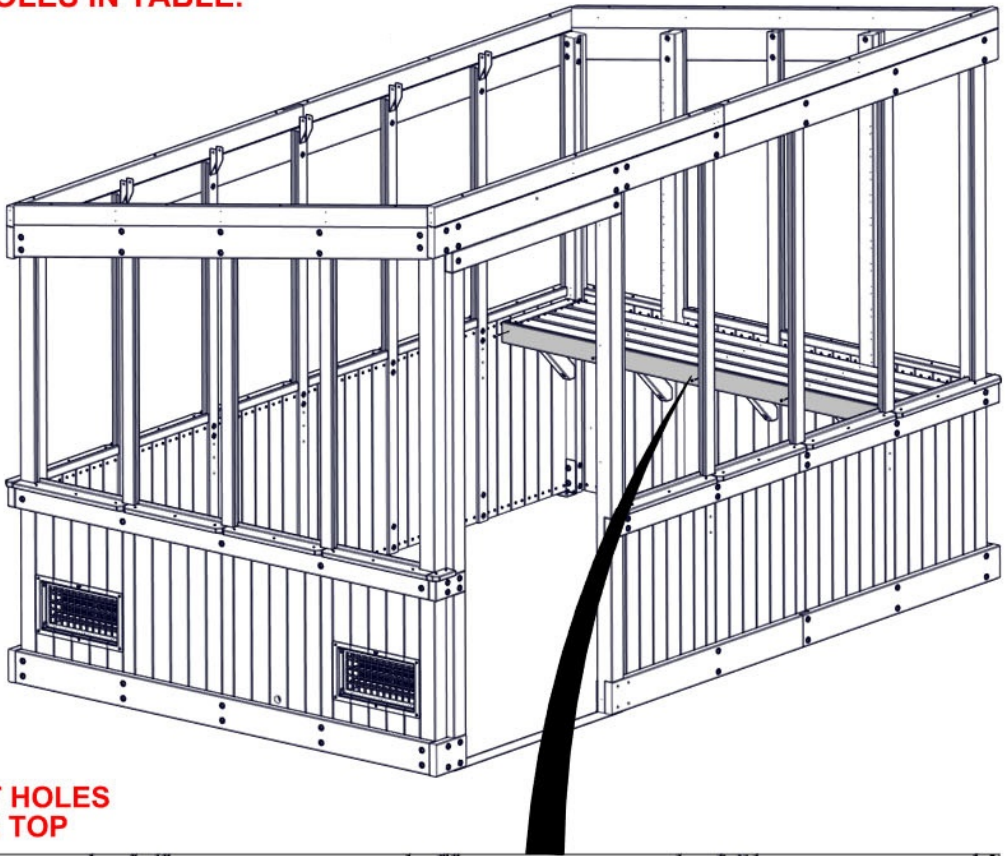

NOTE ORIENT HOLES TOWARD THE TOP

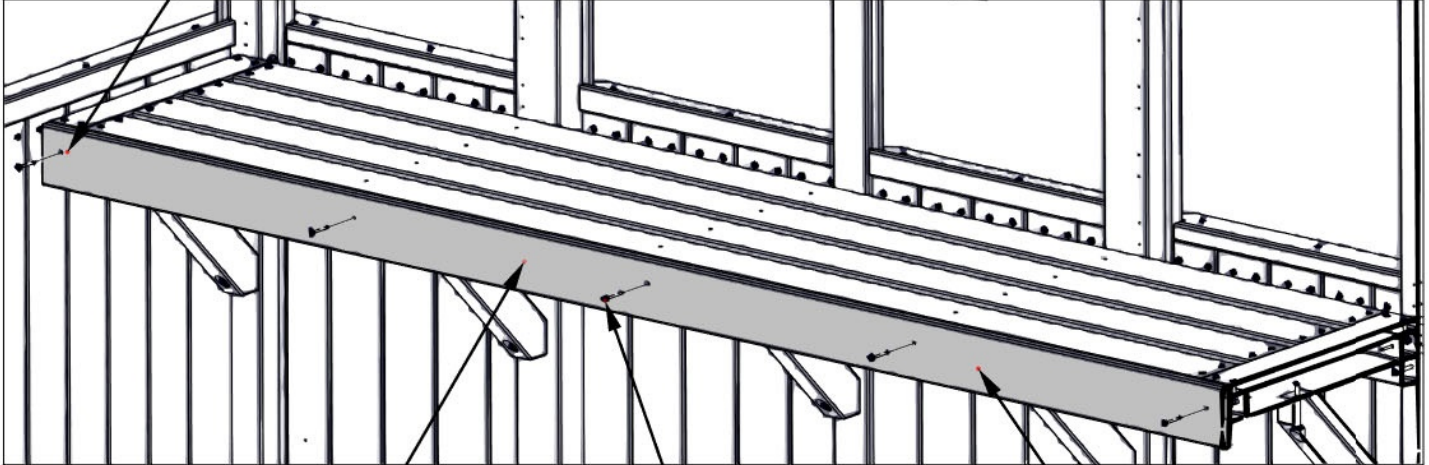

M05 (x1)
TABLE TRIM

200 (x5)
SCREW - 1 1/2"

ALIGN M05 WITH TOP & SIDES OF TABLE

STEP 27 - LEFT TABLE

Qty	PART NUMBER	DESCRIPTION
2	H100201	SCREW PFH 8 X 2 1/2 BLK
4	H100387	SCREW PFH 8 X 1 1/4 BLK

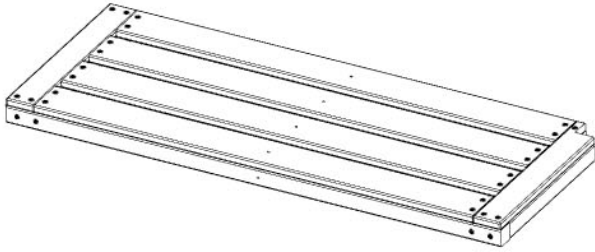

TP04 LEFT TABLE ASSEMBLY - W2A03996
(x1) 2 1/16"x16"x41 1/2" (52x407x934)



F08 TABLE FRAME BOARD - W4L18748
(x1) 1 7/16"x1 7/16"x13 1/8" (36x36x333)

1. FLIP TABLE UPSIDE DOWN & INSERT BOARDS & HARDWARE AS SHOWN.

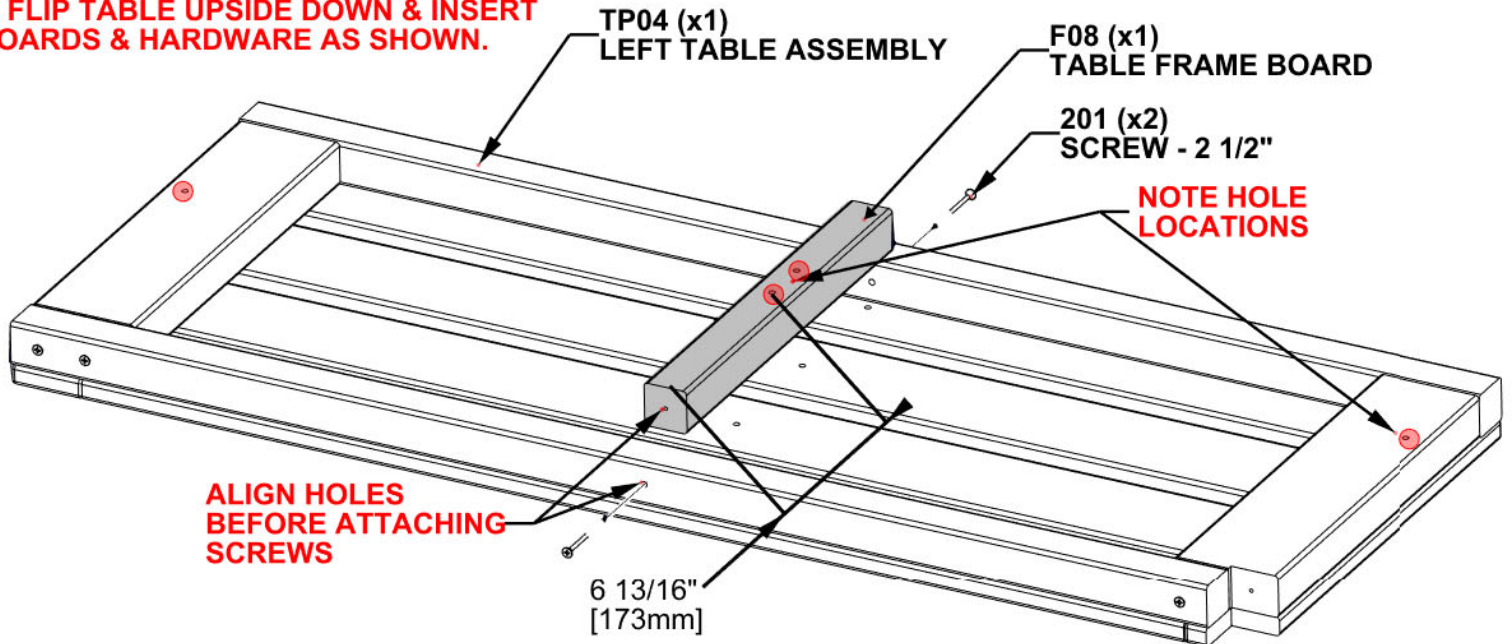

2. FLIP TABLE & INSERT HARDWARE AS SHOWN.

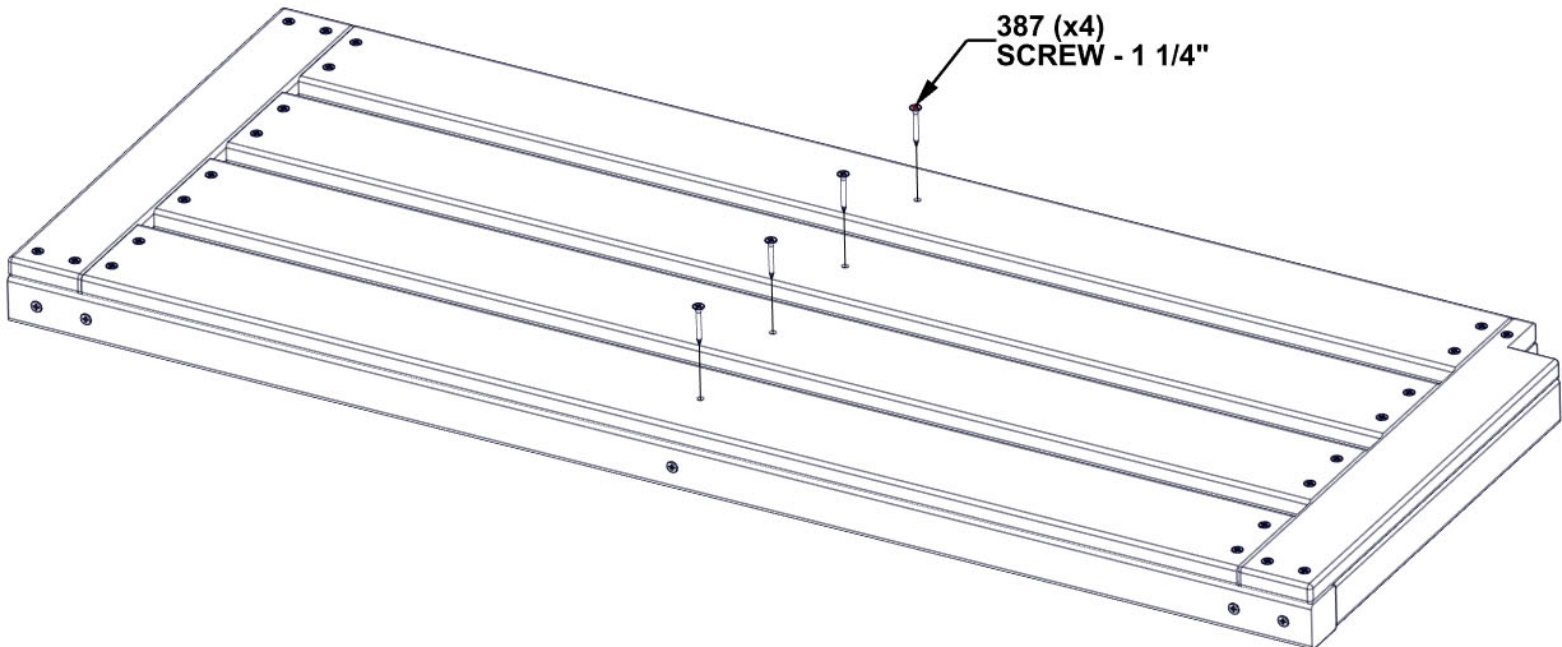

**SET STEP 27 ASSEMBLY
TO THE SIDE**

STEP 28 - LEFT TABLE

Qty	PART NUMBER	DESCRIPTION
2	H100483	SCREW PFH 8 X 2 1/4 BLK

P13 CLEAT - W4L18797
(x1) 1 7/16"x1 7/16"x39 15/16" (36x36x1014)

NOTES:
ALIGN BOARD WITH PILOT HOLES
BEFORE ATTACHING SCREWS.

LEFT

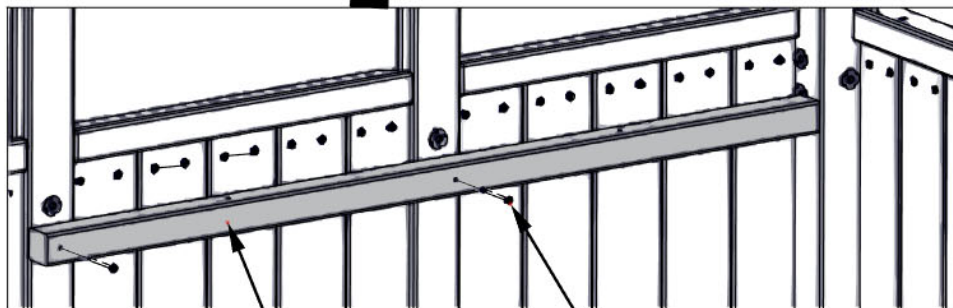
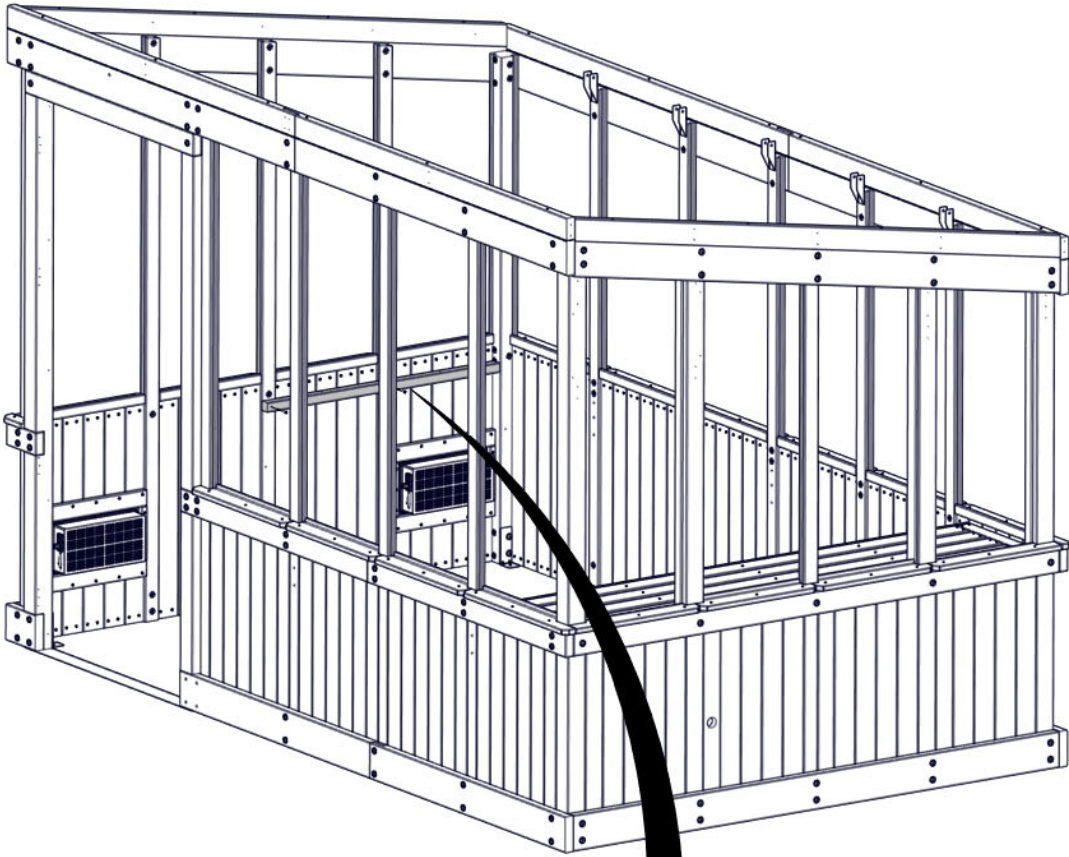

P13 (x1)
CLEAT

483 (x2)
SCREW - 2 1/4"

STEP 29 - LEFT TABLE

Qty	PART NUMBER	DESCRIPTION
3	H100405	WASHER LOCK EXT 6X15 BLK
3	H100792	LAG SCREW WH 1/4 X 3 BLK



F09 DIAGONAL BRACE - W4L18749
 (x3) 1 7/16"x2 3/8"x15 3/16" (36x60x385)

- NOTES:**
- HAND TIGHTEN ONLY
 - ALIGN BRACE WITH PILOT HOLES BEFORE ATTACHING SCREWS.

LEFT

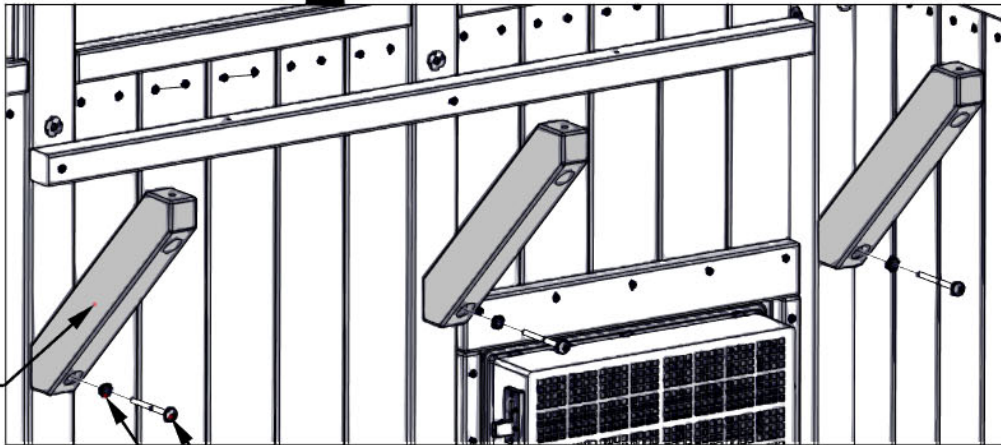
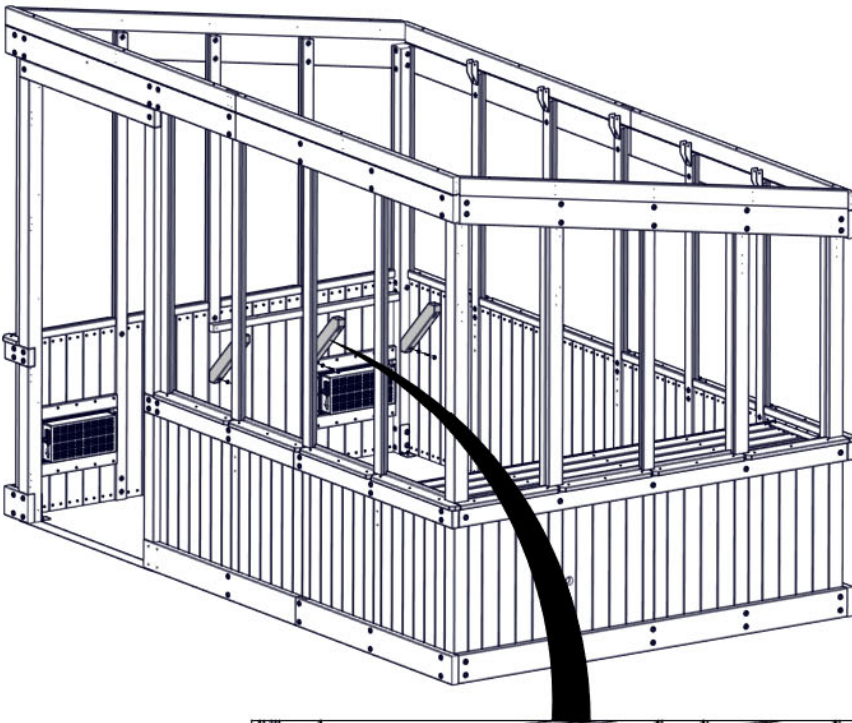

F09 (x3)
 DIAGONAL BRACE

792 (x3)
 LAG SCREW - 3"

405 (x3)
 WASHER - 6x15

STEP 30 - LEFT TABLE

Qty	PART NUMBER	DESCRIPTION
3	H100405	WASHER LOCK EXT 6X15 BLK
3	H100456	LAG SCREW WH 1/4 X 2 1/2 BLK

- NOTES:**
- ALIGN PILOT HOLES IN TABLE WITH BRACES AND ATTACH AS SHOWN.
 - IMPORTANT! TIGHTEN ALL HARDWARE FOR TABLE.

LEFT

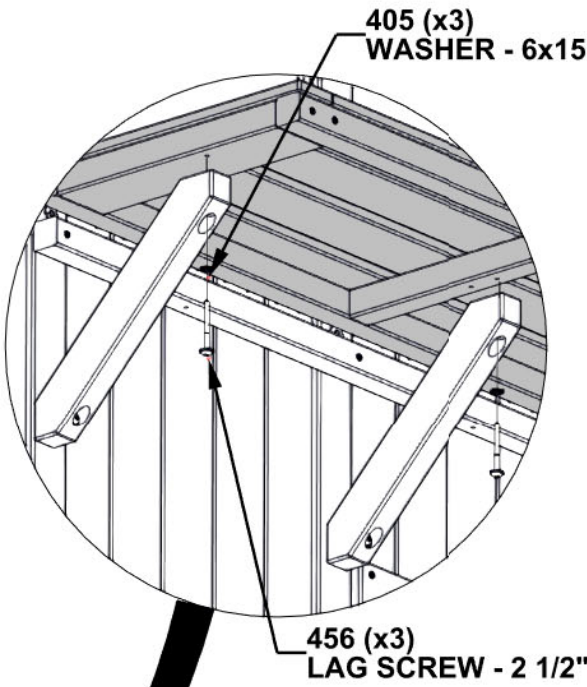
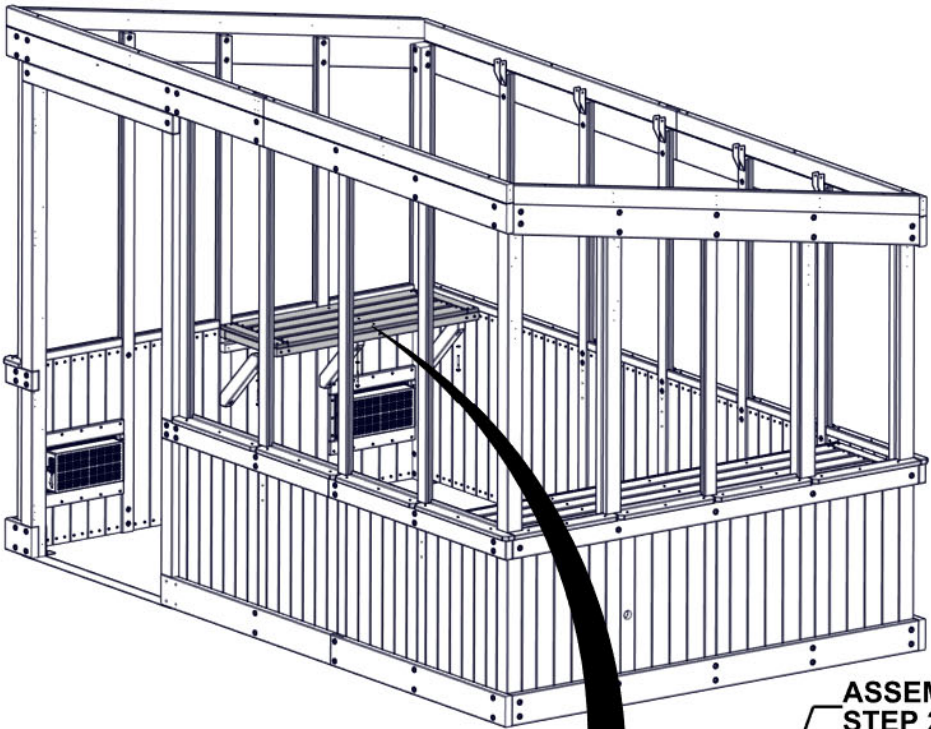

ASSEMBLY FROM STEP 27

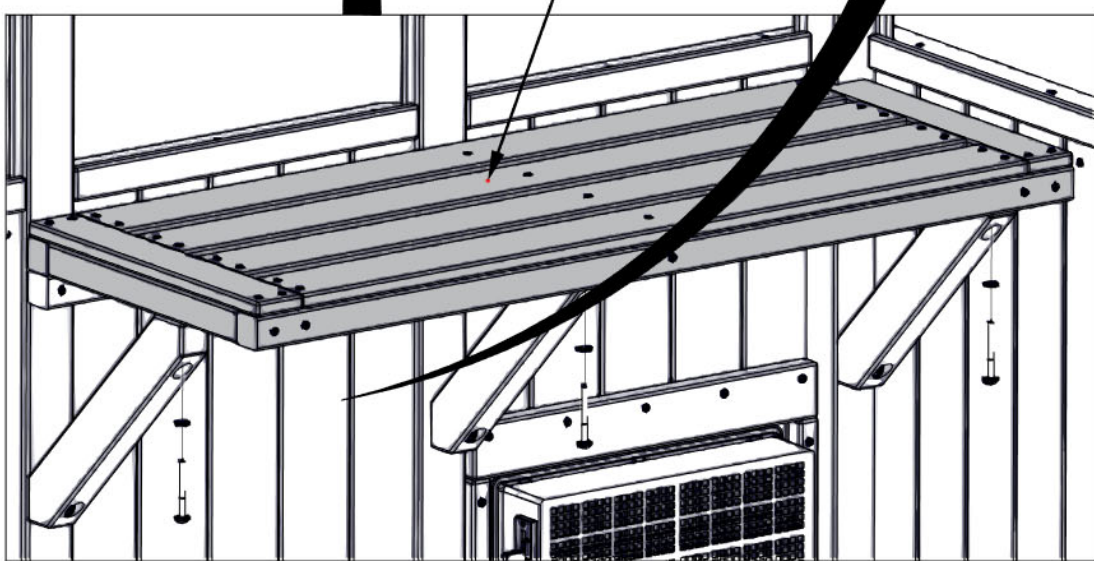

STEP 31 - LEFT TABLE

Qty	PART NUMBER	DESCRIPTION
2	H100391	SCREW PFH 8 X 2 BLK

- NOTES:**
- USE AN 1/8" [3mm] DRILL BIT TO CREATE PILOT HOLES IN CLEAT.
 - DO NOT DRILL THROUGH THE FIRST BOARD OF TABLE.

LEFT

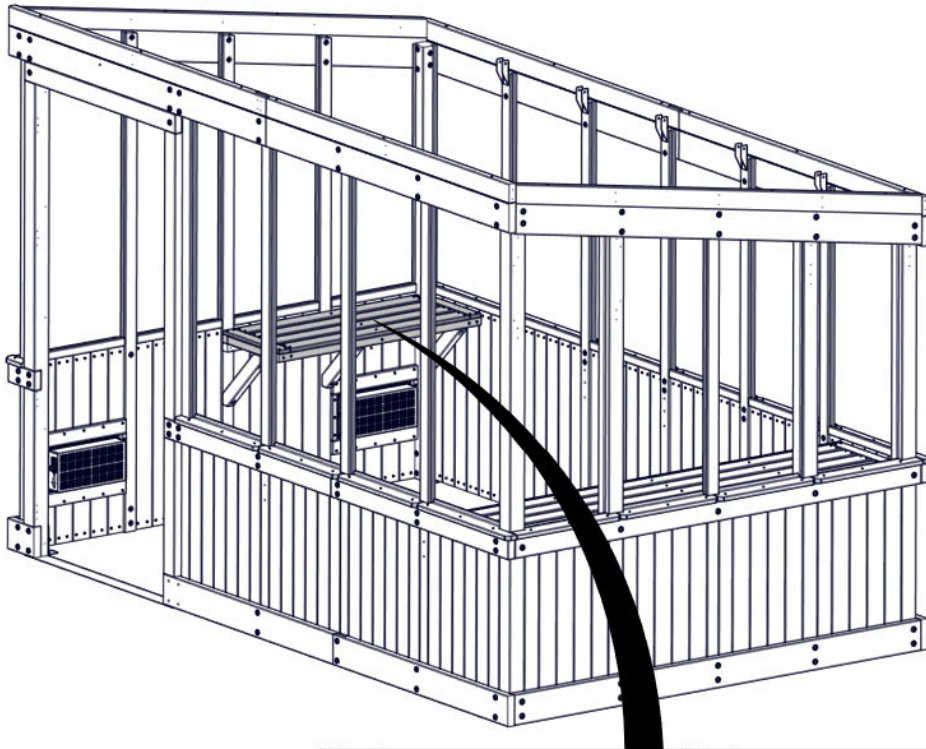

391 (x2)
SCREW - 2"

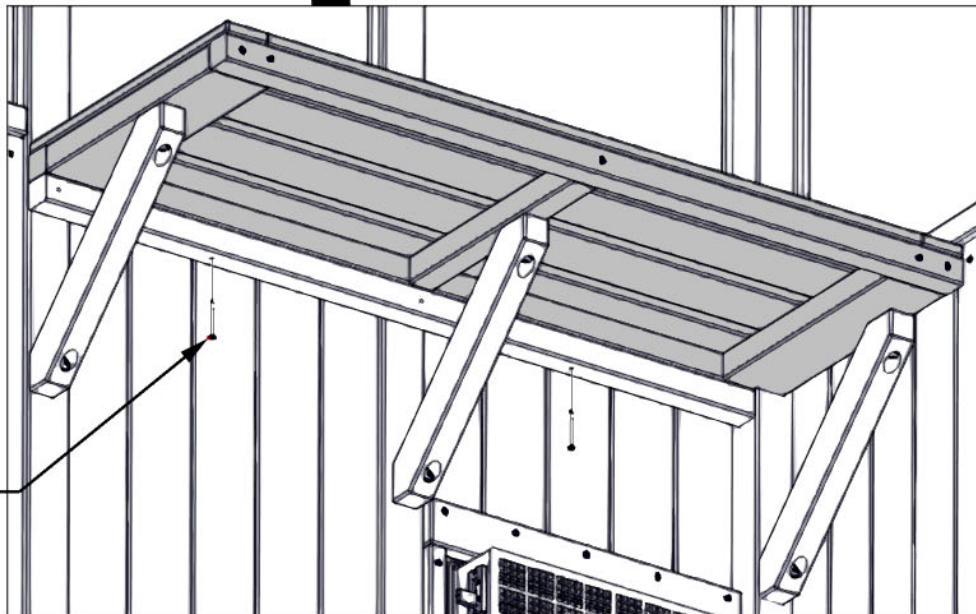

STEP 32 - LEFT TABLE

Qty	PART NUMBER	DESCRIPTION
5	H100200	SCREW PFH 8 X 1 1/2 BLK



M06 TABLE TRIM - W4L18807
(x1) 5/8"x3 3/8"x41 1/2" (16x86x1054)

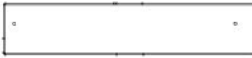

M09 TABLE TRIM - W4L18817
(x1) 5/8"x3 3/8"x16 5/8" (16x86x423)

NOTE:
USE M06 & M09 BOARDS AS A GUIDE AND AN 1/8" [3mm] DRILL BIT TO CREATE PILOT HOLES IN TABLE.

LEFT

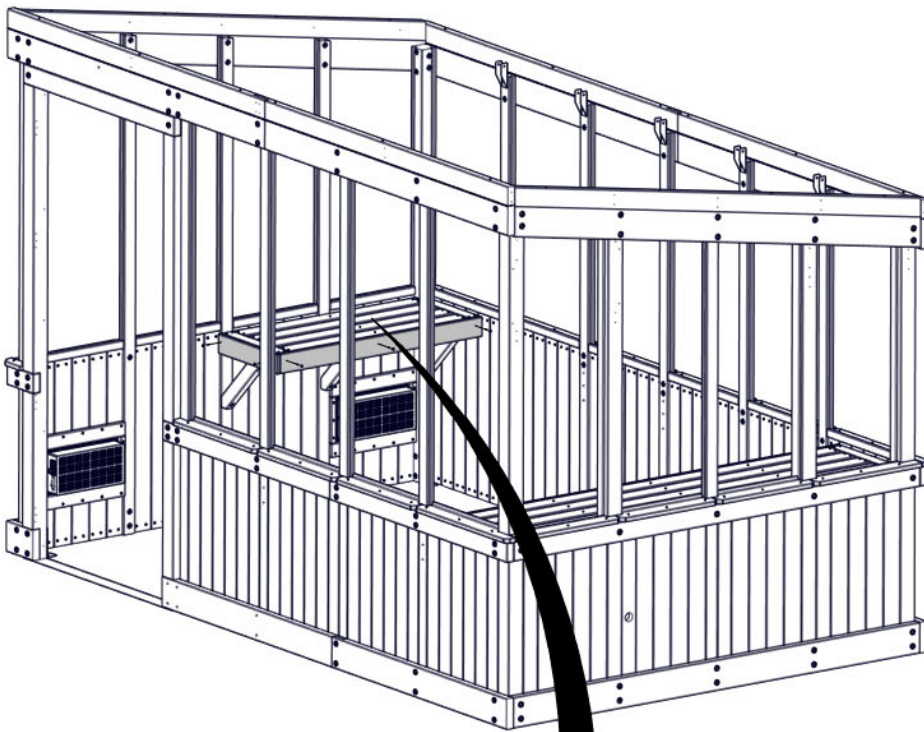

1. ATTACH M06 FIRST
ALIGN WITH TOP
& SIDES OF TABLE.

2. ALIGN M09 WITH TOP
AND FRONT OF M06

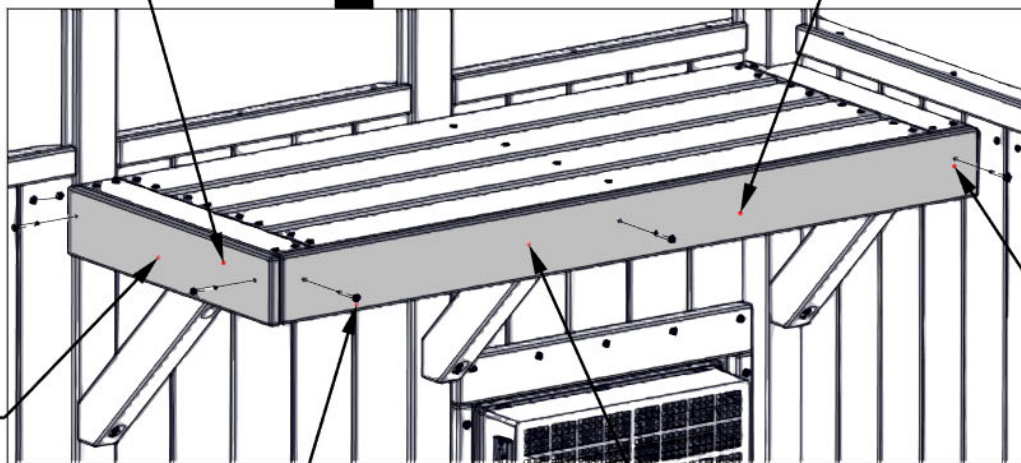

NOTE ORIENT HOLES
TOWARD THE TOP

M09 (x1)
TABLE TRIM

200 (x5)
SCREW - 1 1/2"

M06 (x1)
TABLE TRIM

STEP 33 - TABLE BRACKETS

Qty	PART NUMBER	DESCRIPTION
18	H100405	WASHER LOCK EXT 6X15 BLK
18	H100488	BOLT WH 1/4 X 2 BLK
18	H100630	WASHER FLAT 8x19 BLK
18	H100653	NUT LOCK 1/4 BLK

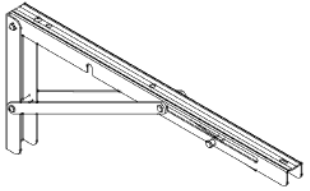

A4M02094 FOLDING TABLE BRACKET
(x6)

- NOTES:**
- ON HIGHLIGHTED UPRIGHTS, PUSH BOLTS IN FROM THE OUTSIDE THROUGH TABLE BRACKETS AS SHOWN.
 - EXTRA PEOPLE NEEDED FOR THIS STEP.
 - HAND TIGHTEN ONLY

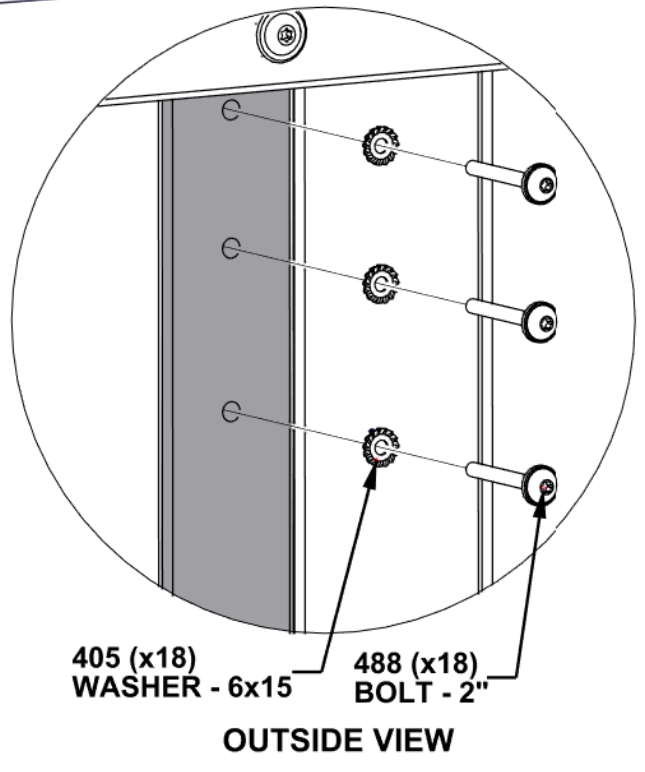
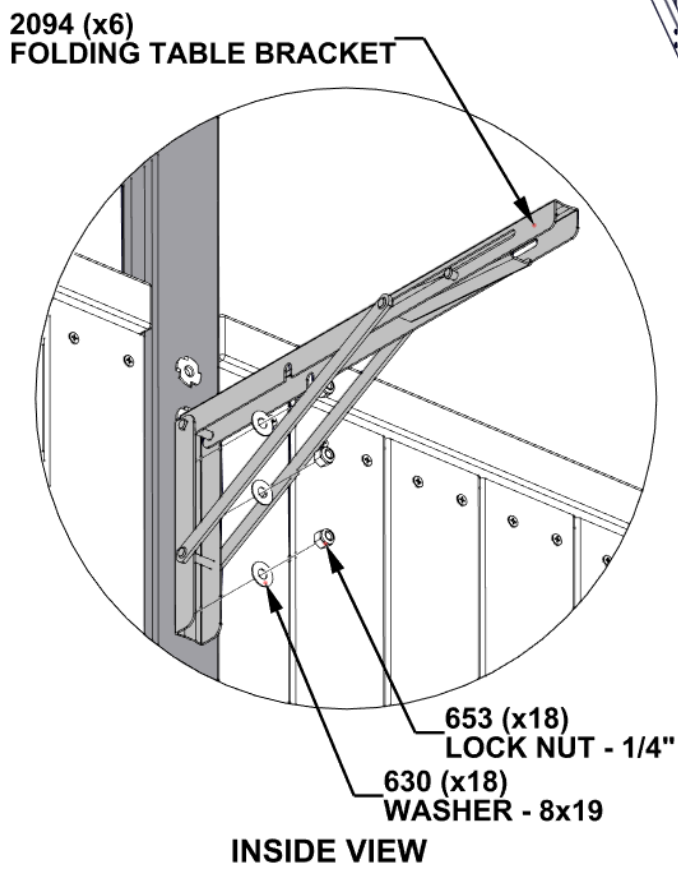
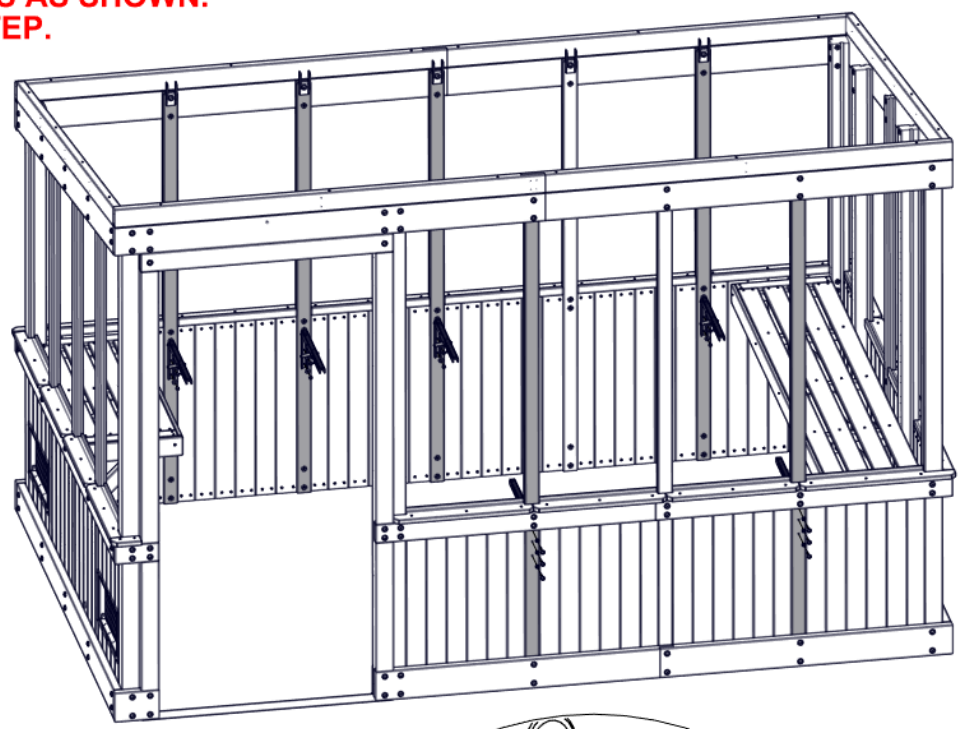

STEP 34 - BACK LONG TABLE

Qty	PART NUMBER	DESCRIPTION
6	H100201	SCREW PFH 8 X 2 1/2 BLK
12	H100387	SCREW PFH 8 X 1 1/4 BLK

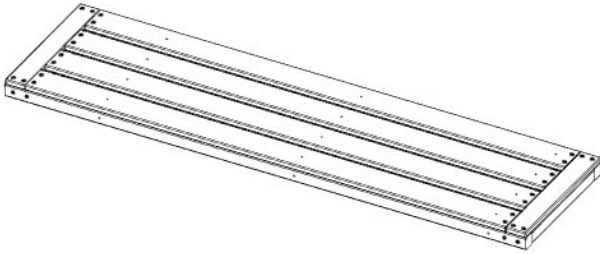

TP02 MID LONG TABLE ASSEMBLY - W2A03994
(x1) 2 1/16"x16"x60 1/16" (52x407x1406)



P16 TABLE FRAME BOARD - W4L18804
(x3) 1 7/16"x1 7/16"x13 1/8" (36x36x333)

1. FLIP TABLE UPSIDE DOWN & INSERT BOARDS & HARDWARE AS SHOWN.

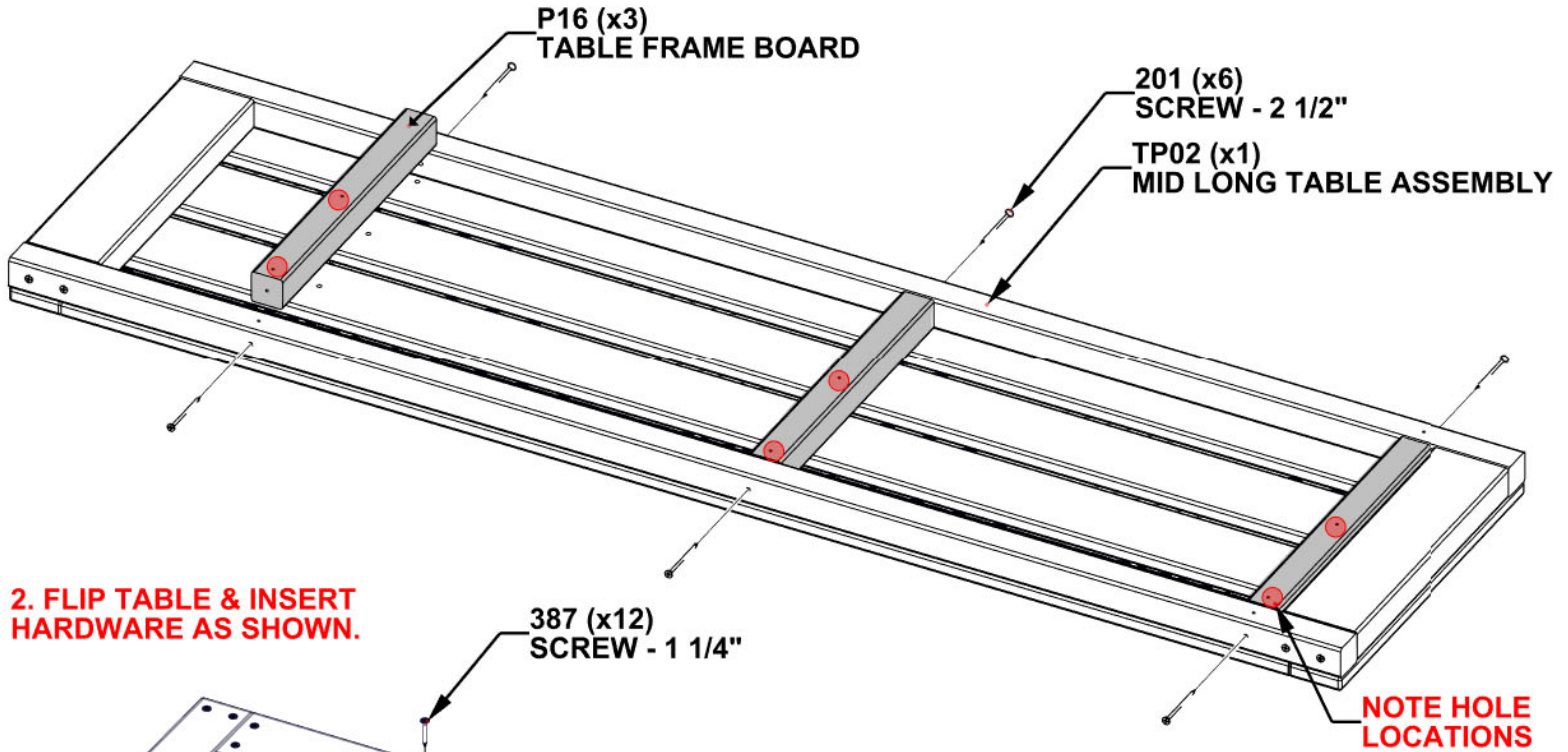

2. FLIP TABLE & INSERT HARDWARE AS SHOWN.

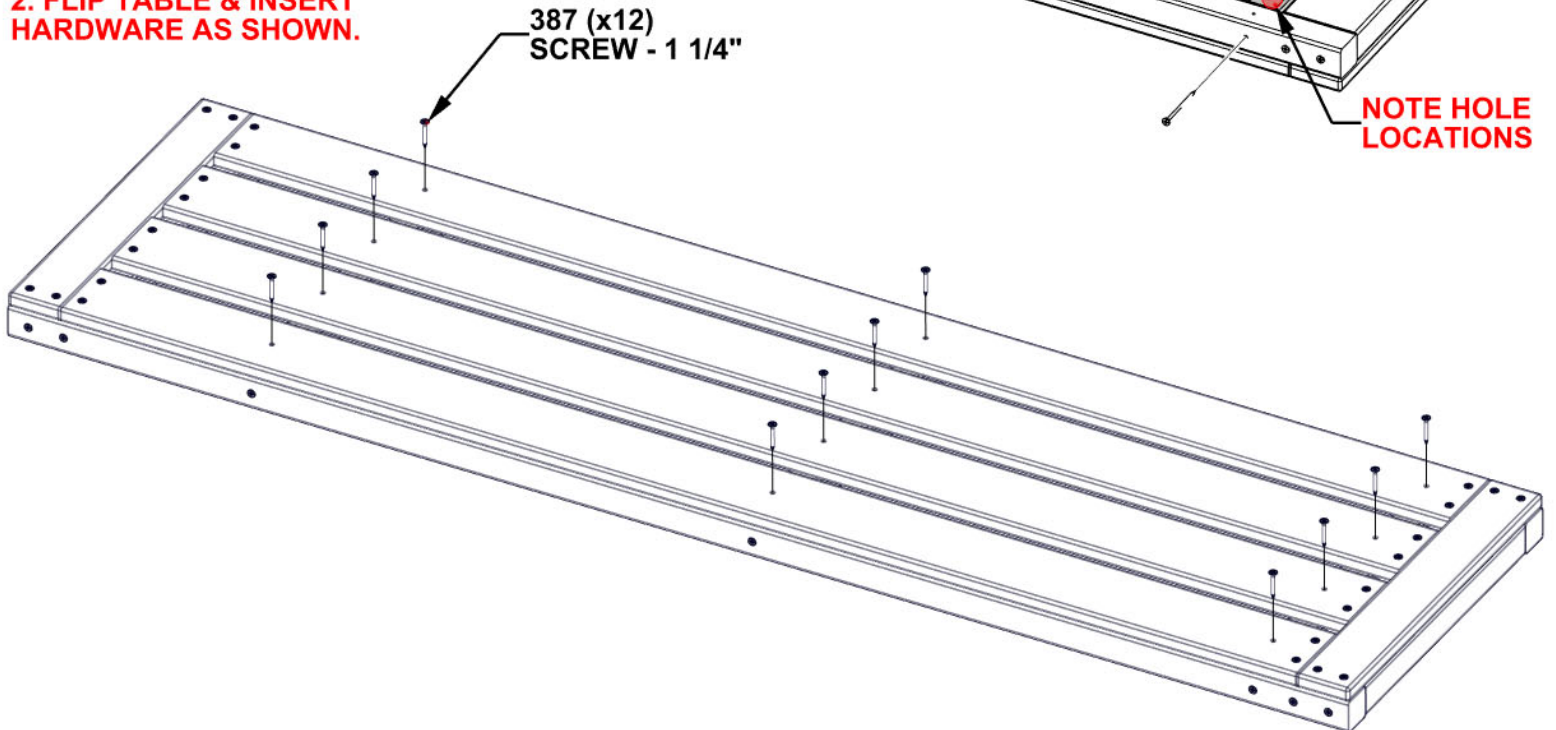

STEP 35 - BACK LONG TABLE

Qty	PART NUMBER	DESCRIPTION
6	H100797	SCREW PWH 8 X 1 BLK

- NOTES:**
- **ALIGN BRACKET & PILOT HOLES IN TABLE BEFORE ATTACHING SCREWS.**
 - **IMPORTANT! TIGHTEN HARDWARE FOR TABLE BRACKETS.**

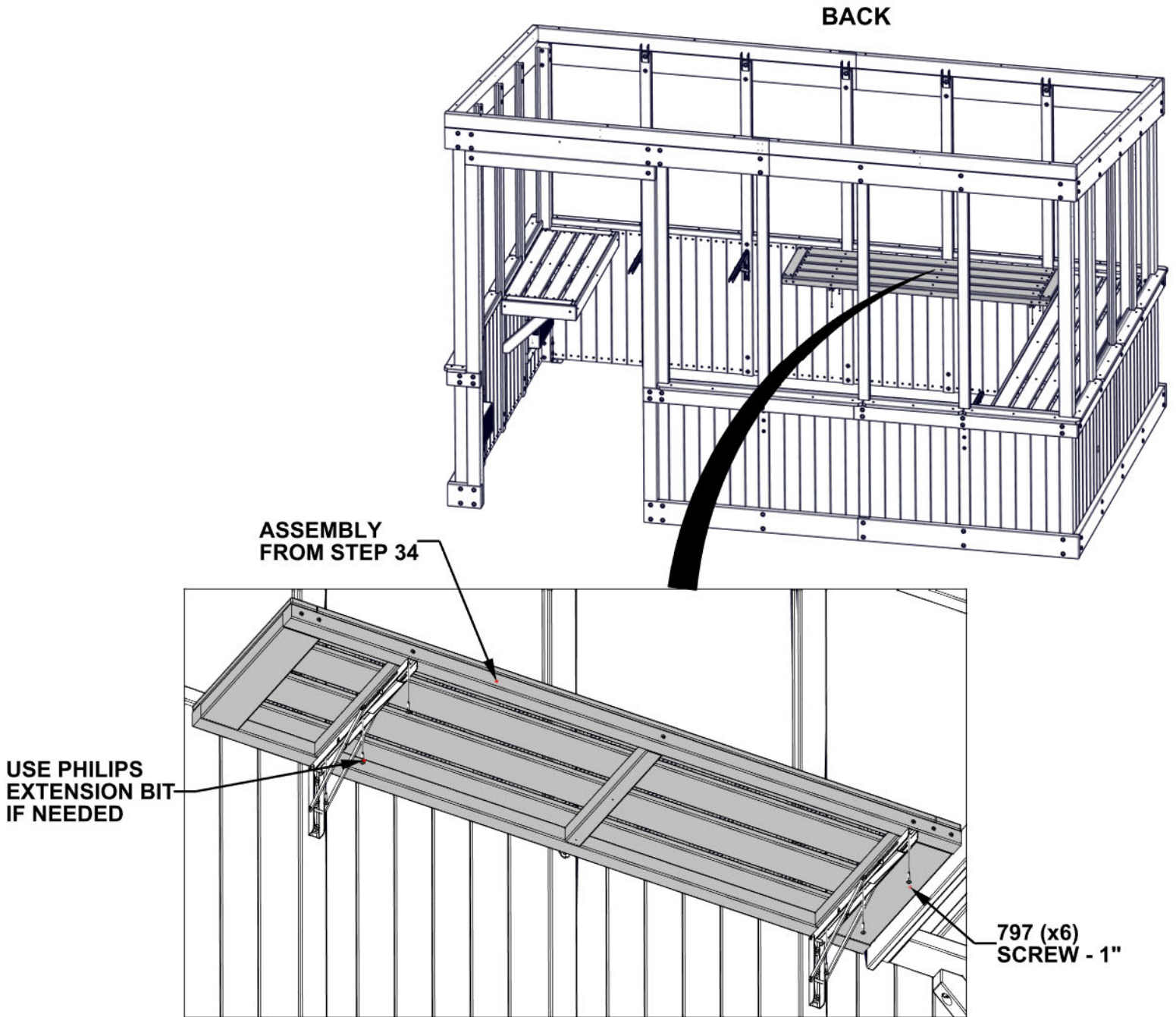

STEP 36 - BACK LONG TABLE

Qty	PART NUMBER	DESCRIPTION
4	H100200	SCREW PFH 8 X 1 1/2 BLK



M07 TABLE TRIM - W4L18808
(x1) 5/8"x3 3/8"x60 1/16" (16x86x1526)

NOTES:
ALIGN TABLE TRIM FLUSH WITH TOP & SIDES
OF TABLE BEFORE ATTACHING SCREWS.

BACK

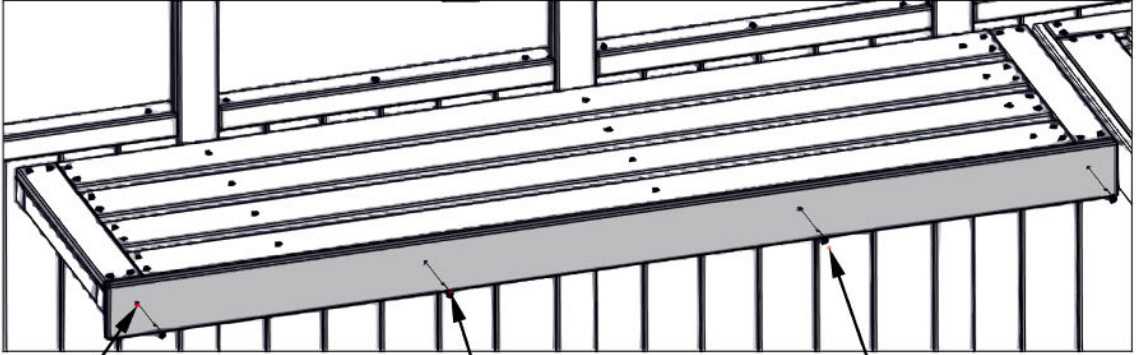
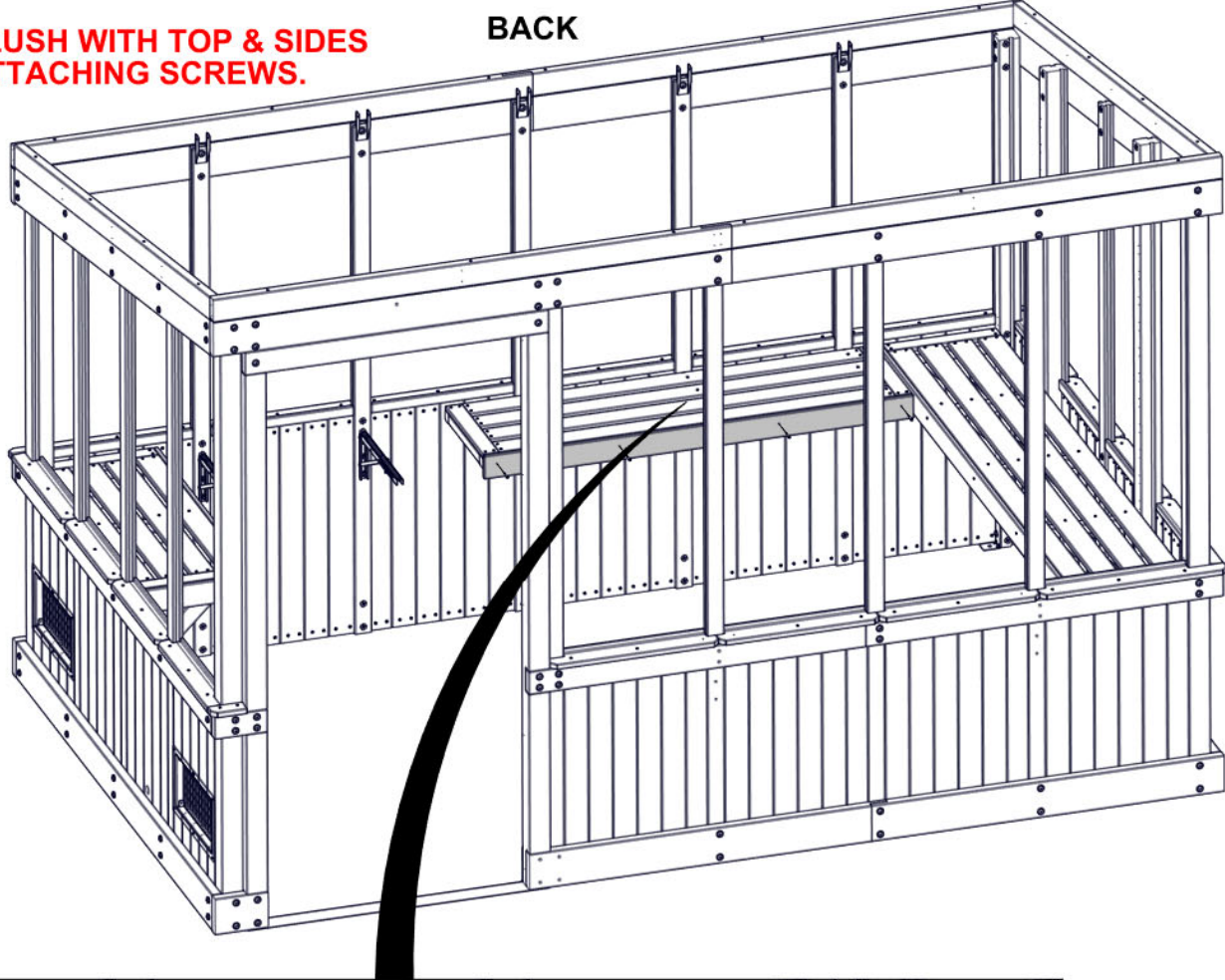

NOTE ORIENT HOLES
TOWARDS THE TOP

M07 (x1)
TABLE TRIM

200 (x4)
SCREW - 1 1/2"

STEP 37 - BACK SHORT TABLE

Qty	PART NUMBER	DESCRIPTION
4	H100201	SCREW PFH 8 X 2 1/2 BLK
8	H100387	SCREW PFH 8 X 1 1/4 BLK

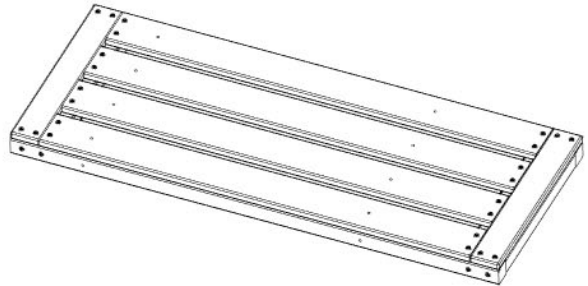

TP03 MID SHORT TABLE ASSEMBLY - W2A03995
 (x1) 2 1/16"x16"x39 1/2" (52x407x884)

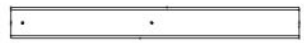

P16 TABLE FRAME BOARD - W4L18804
 (x2) 1 7/16"x1 7/16"x13 1/8" (36x36x333)

1. FLIP TABLE UPSIDE DOWN & INSERT BOARDS & HARDWARE AS SHOWN.

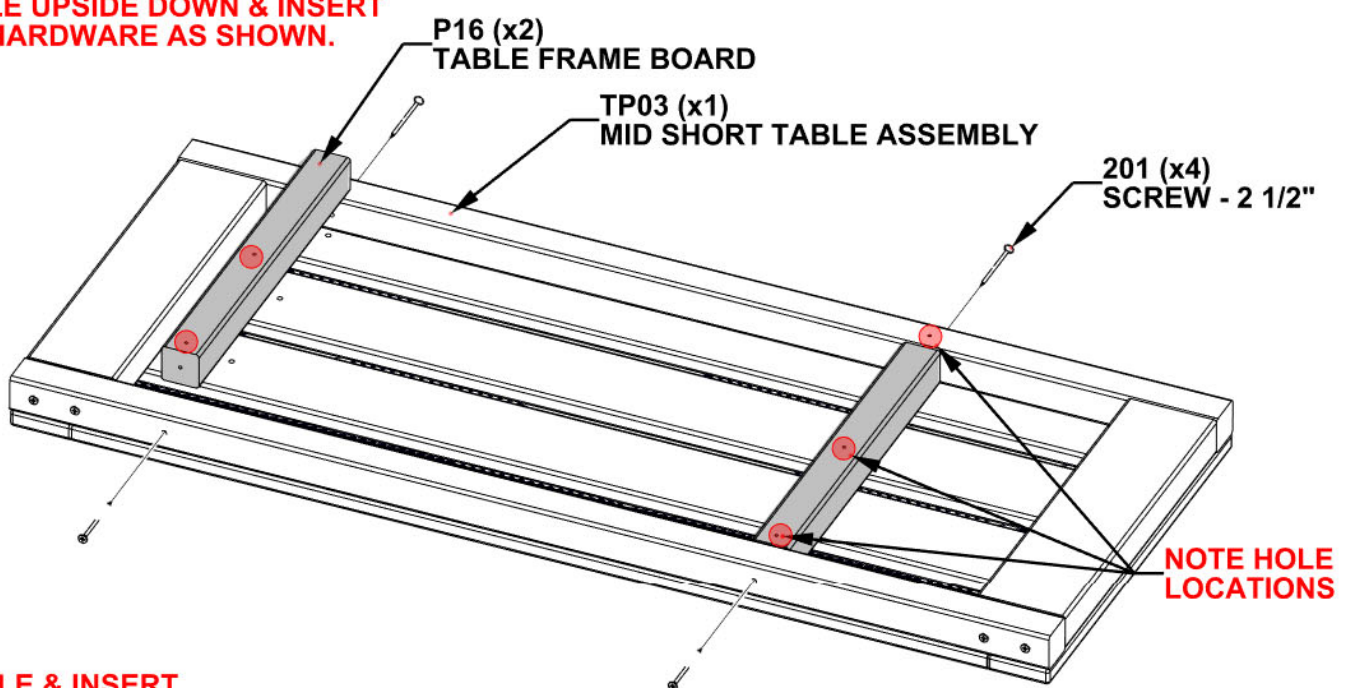

2. FLIP TABLE & INSERT HARDWARE AS SHOWN.

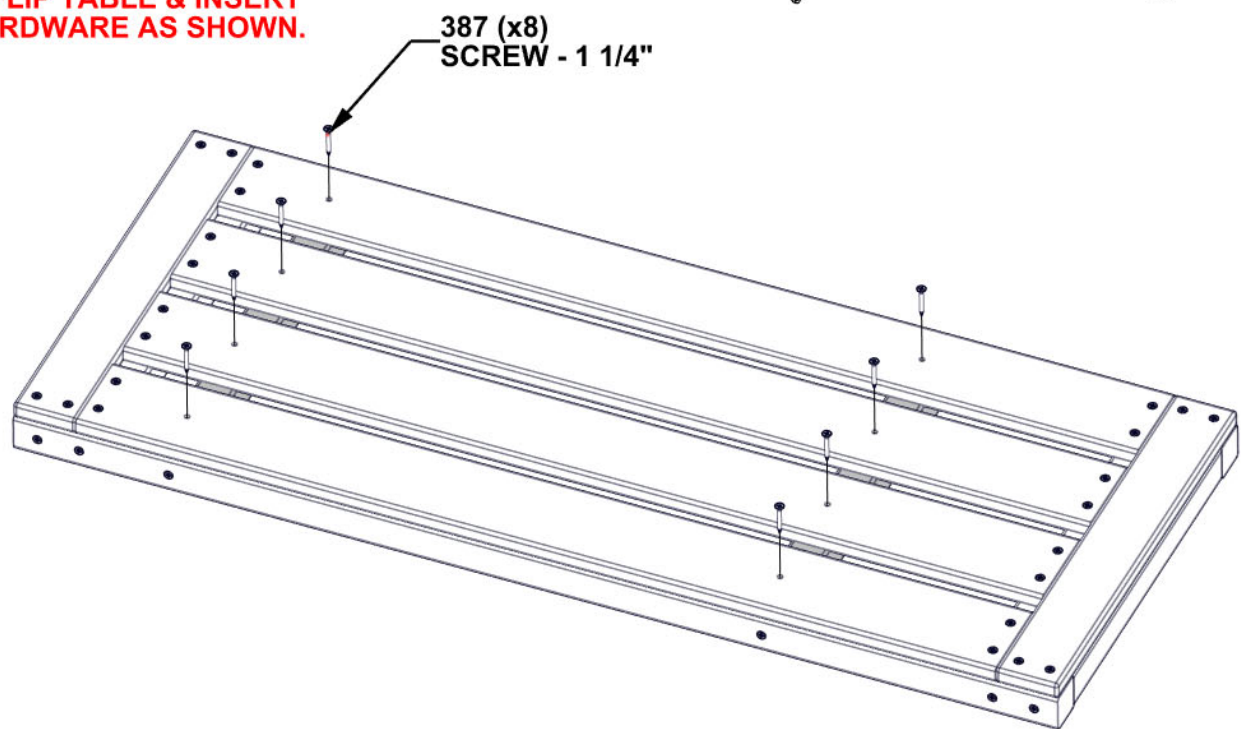

STEP 38 - BACK SHORT TABLE

Qty	PART NUMBER	DESCRIPTION
6	H100797	SCREW PWH 8 X 1 BLK

- NOTES:**
- **ALIGN BRACKET & PILOT HOLES IN TABLE BEFORE ATTACHING SCREWS.**
 - **IMPORTANT! TIGHTEN HARDWARE FOR TABLE BRACKETS.**

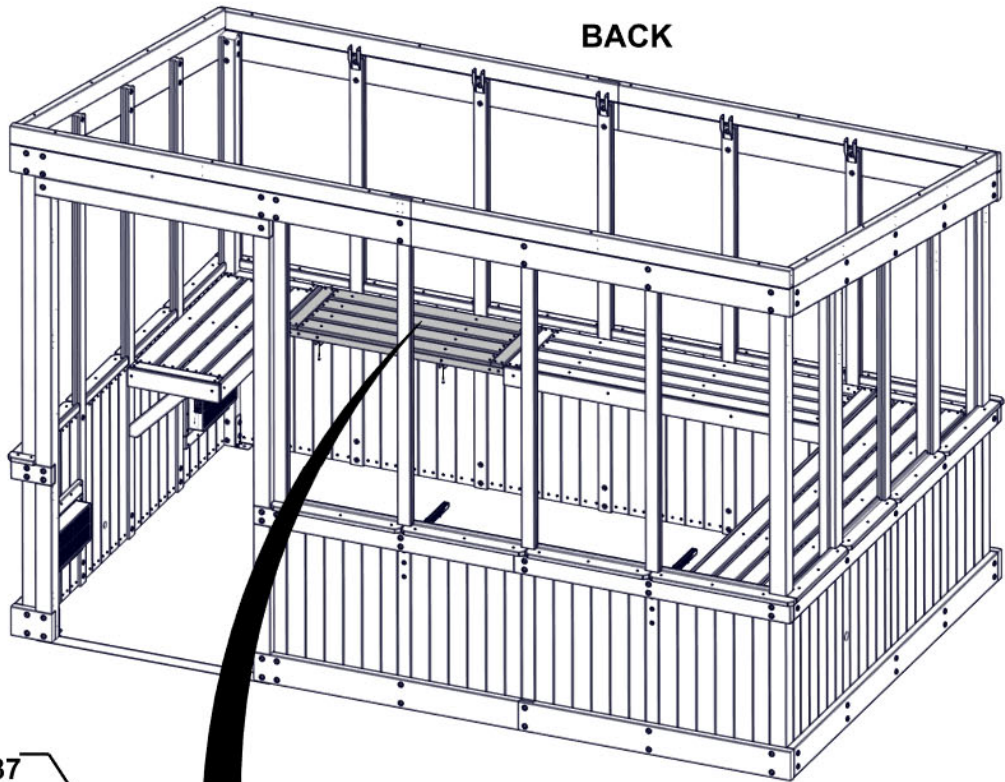

ASSEMBLY FROM STEP 37

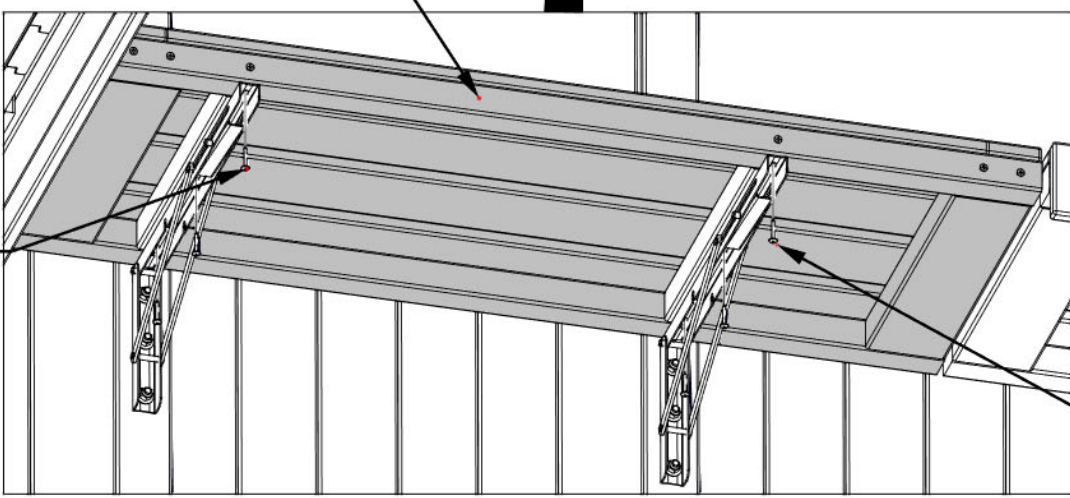

USE PHILIPS EXTENSION BIT IF NEEDED

797 (x6) SCREW - 1"

STEP 39 - BACK SHORT TABLE

Qty	PART NUMBER	DESCRIPTION
4	H100200	SCREW PFH 8 X 1 1/2 BLK



M08 TABLE TRIM - W4L18809
(x1) 5/8"x3 3/8"x39 1/2" (16x86x1004)

NOTES:
ALIGN TABLE TRIM FLUSH WITH TOP & SIDES
OF TABLE BEFORE ATTACHING SCREWS.

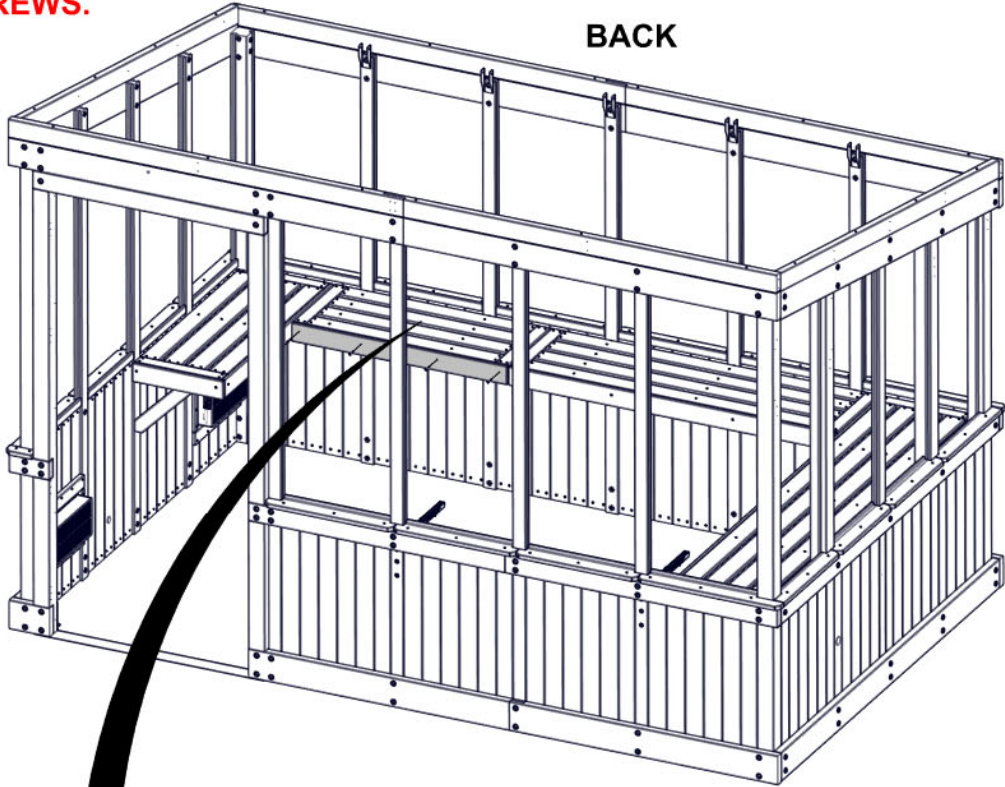

NOTE ORIENT HOLES TOWARDS THE TOP

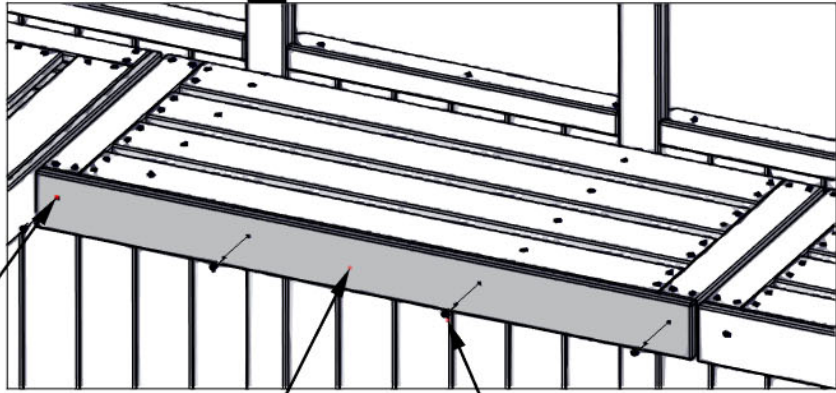

M08 (x1)
TABLE TRIM

200 (x4)
SCREW - 1 1/2"

STEP 40 - FRONT LONG TABLE

Qty	PART NUMBER	DESCRIPTION
6	H100201	SCREW PFH 8 X 2 1/2 BLK
12	H100387	SCREW PFH 8 X 1 1/4 BLK

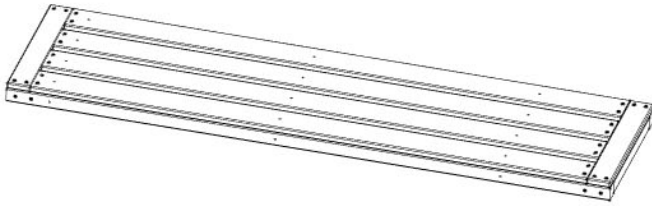

TP02 MID LONG TABLE ASSEMBLY - W2A03994
(x1) 2 1/16"x16"x60 1/16" (52x407x1406)



P16 TABLE FRAME BOARD - W4L18804
(x3) 1 7/16"x1 7/16"x13 1/8" (36x36x333)

1. FLIP TABLE UPSIDE DOWN & INSERT BOARDS & HARDWARE AS SHOWN.

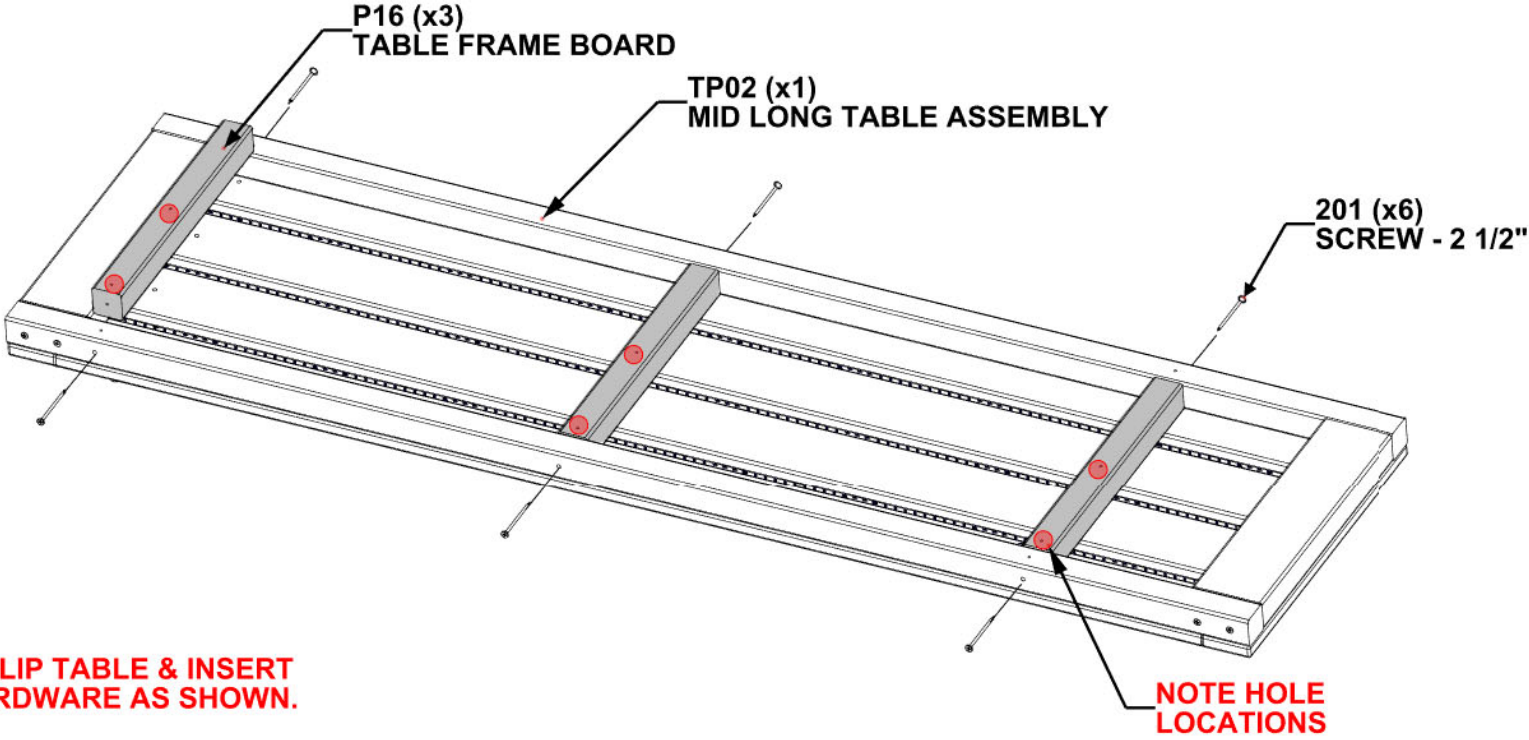

2. FLIP TABLE & INSERT HARDWARE AS SHOWN.

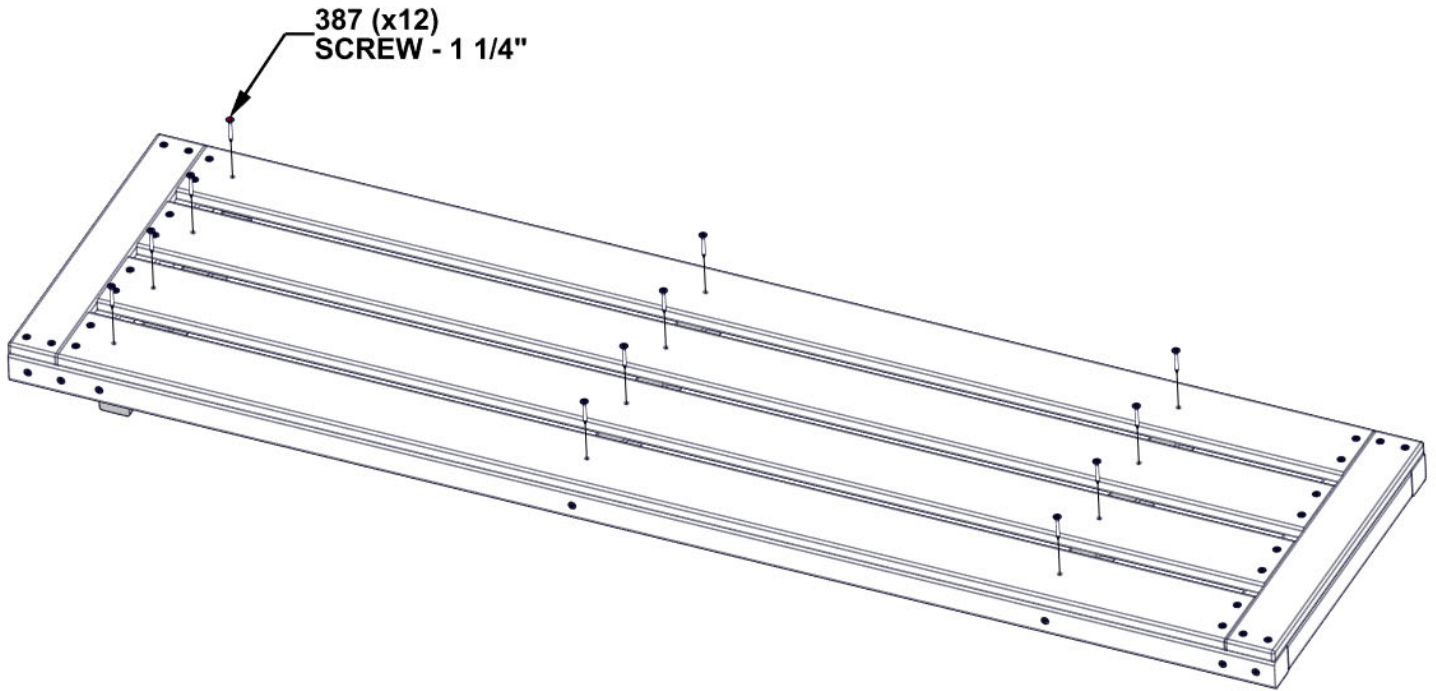

STEP 41 - FRONT LONG TABLE

Qty	PART NUMBER	DESCRIPTION
6	H100797	SCREW PWH 8 X 1 BLK

- NOTES:**
- **ALIGN BRACKET & PILOT HOLES IN TABLE BEFORE ATTACHING SCREWS.**
 - **IMPORTANT! TIGHTEN HARDWARE FOR TABLE BRACKETS.**

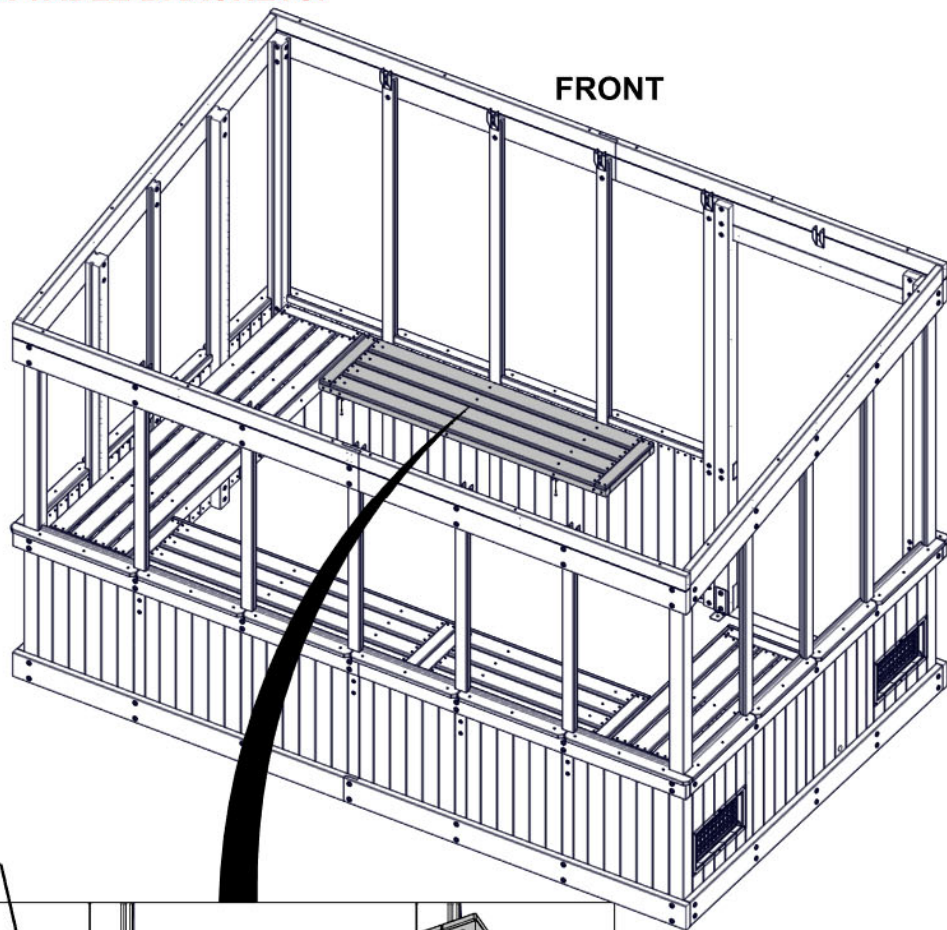

ASSEMBLY FROM STEP 40

USE PHILIPS EXTENSION BIT IF NEEDED

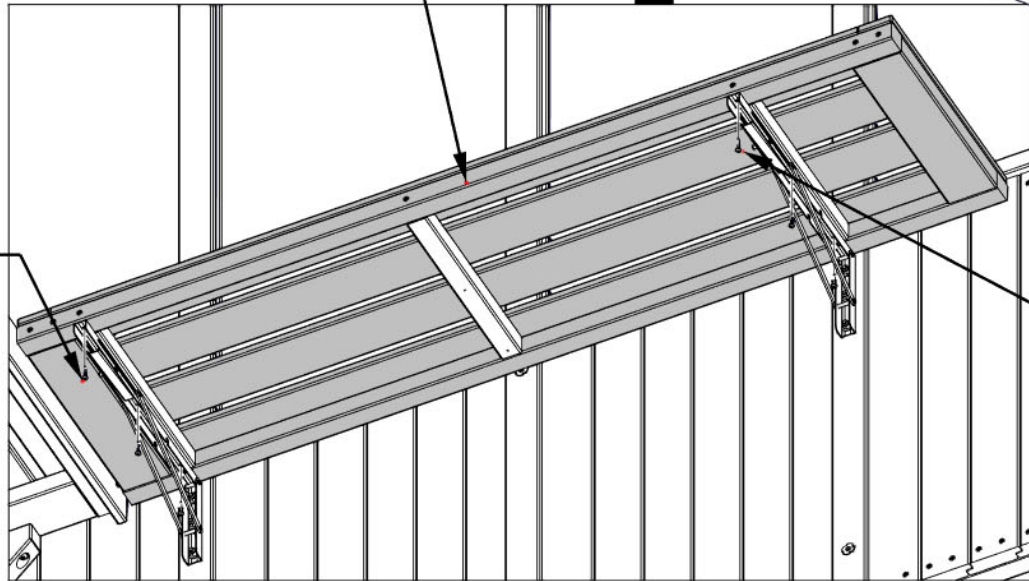

797 (x6)
SCREW - 1"

STEP 42 - FRONT LONG TABLE

Qty	PART NUMBER	DESCRIPTION
6	H100200	SCREW PFH 8 X 1 1/2 BLK



M07 TABLE TRIM - W4L18808
(x1) 5/8"x3 3/8"x60 1/16" (16x86x1526)

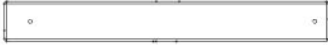

N06 TABLE TRIM - W4L18818
(x1) 5/8"x16 5/8"x2 1/16" (16x52x423)

NOTES:
USE N06 & M07 BOARDS AS A GUIDE AND AN 1/8" [3mm] DRILL BIT TO CREATE PILOT HOLES IN TABLE.

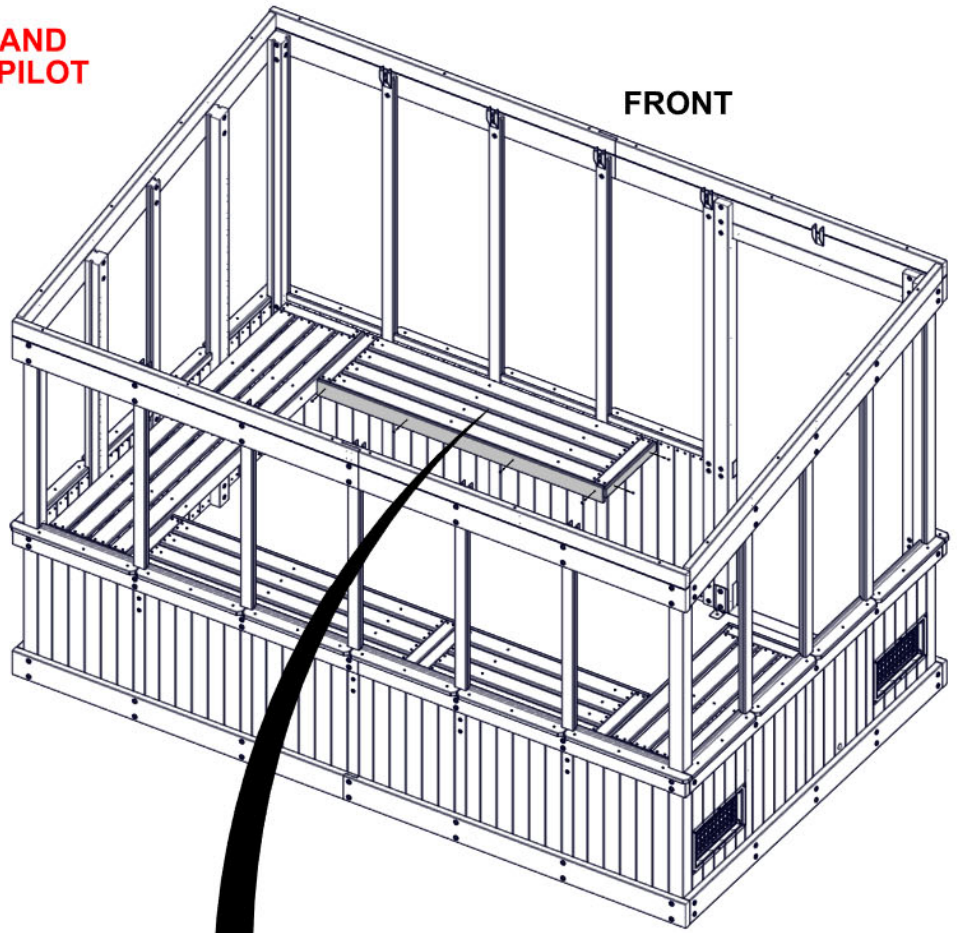

1. ATTACH M07 FIRST. ALIGN WITH TOP & SIDES OF TABLE.

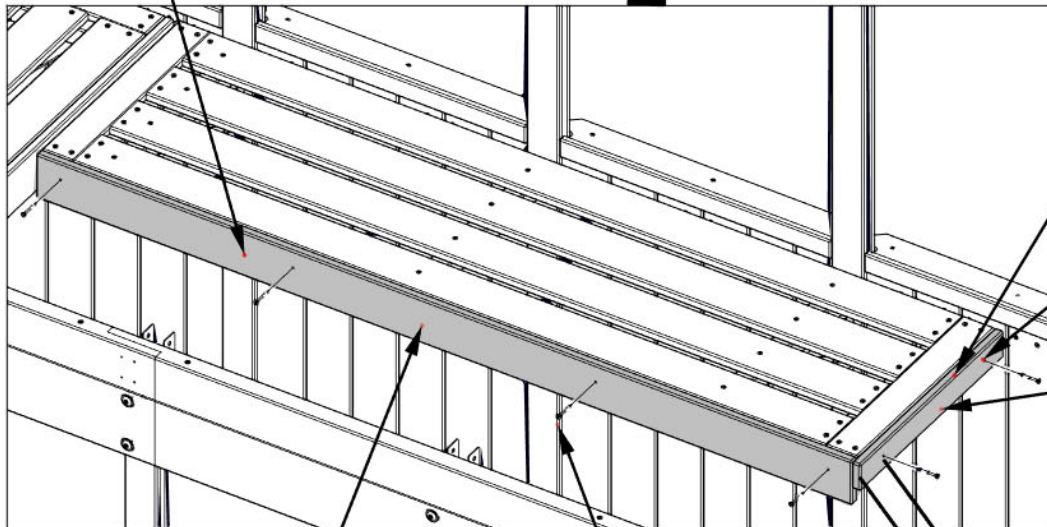

2. ALIGN N06 WITH TOP & FRONT OF M07
NOTE ORIENT HOLES TOWARDS THE TOP

N06 (x1)
TABLE TRIM

M07 (x1)
TABLE TRIM

200 (x6)
SCREW - 1 1/2"

2 3/4"
[70mm]

IMPORTANT!!

Polycarbonate Sheeting Information

The Polycarbonate Sheeting has UV protection on ONE (1) SIDE.

CRITICAL to install with the UV protection facing the OUTSIDE

- Wear safety gloves to protect against any sharp edges during handling or install.
- Do NOT use knife or sharp object to remove protective film as it may result in damage to polycarbonate sheeting
- Leave film on during install to ensure UV side is facing outside.
- Peel protective film back from edges approximately 2" (5cm) during installation.
- Remove film completely after installation.

NOTE: Do not store polycarbonate sheeting with film outside in direct sunlight or rain. It may make removal of film more difficult.

STEP 43 - BACK WINDOWS

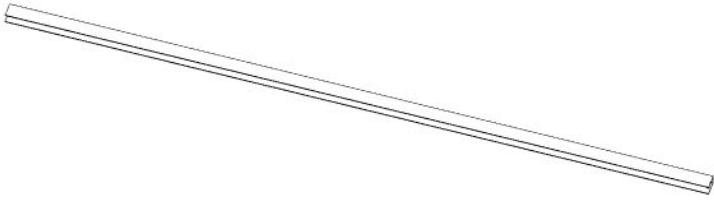

A6P00669 POLY CHANNEL WITH TAPE
(x12)

NOTES:
INSTALL (12) CHANNELS (2 PER WINDOW) BY REMOVING TAPE LINER & PUSH CHANNEL FIRMLY INTO WOOD GROOVES ON UPRIGHTS.



INSERT POLY CHANNEL INTO GROOVES STARTING AT THE WINDOW LEDGE & WORK UPWARDS.

POLY CHANNEL WILL COME WITH DOUBLE SIDED TAPE INSTALLED. REMOVE LINER BEFORE INSTALLATION.

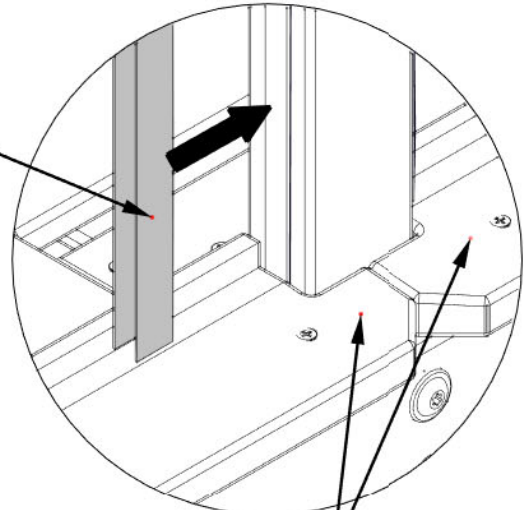

WINDOW LEDGE

**669 (x12)
POLY CHANNEL WITH TAPE**

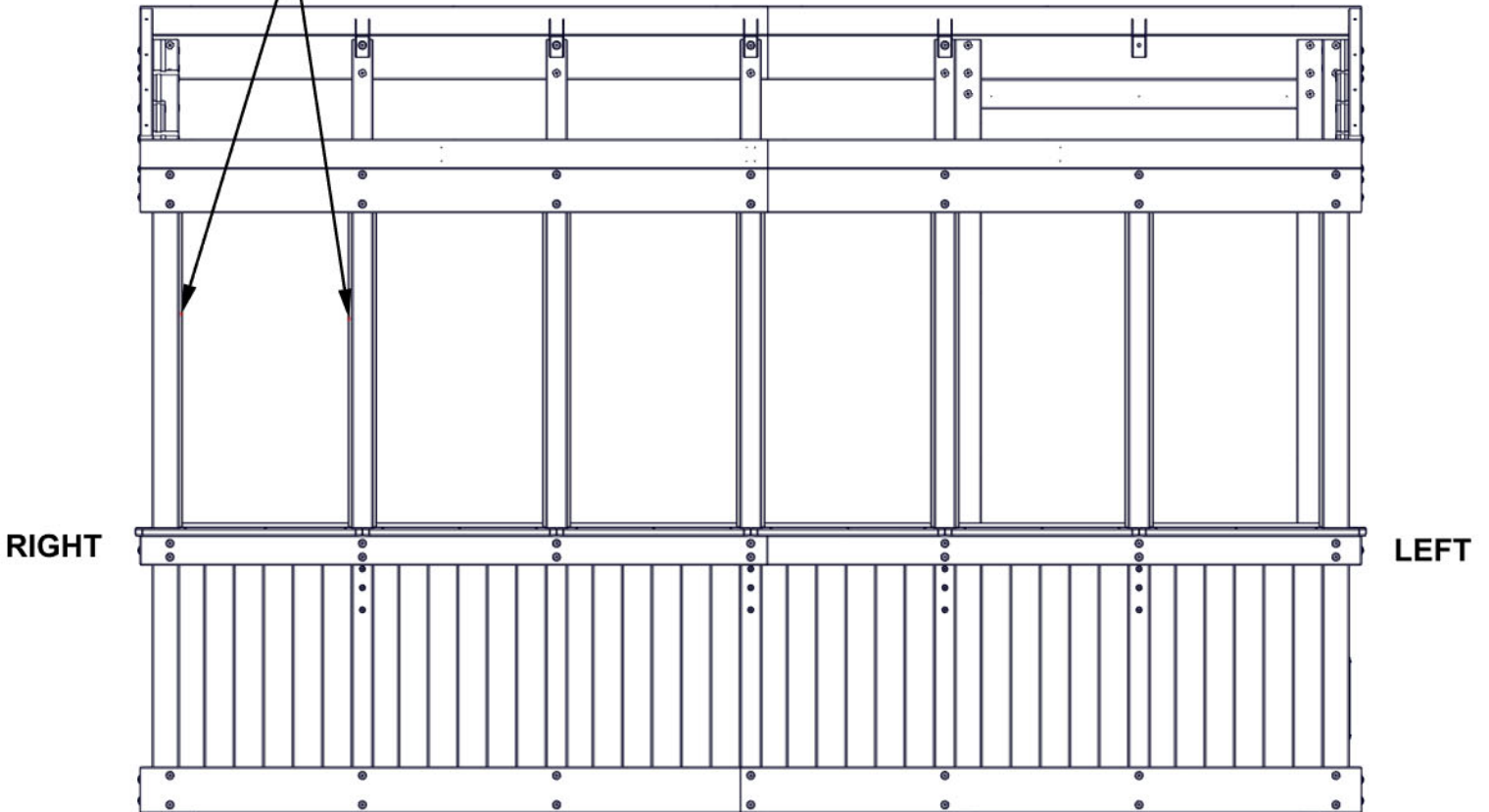

BACK

STEP 44 - BACK WINDOWS

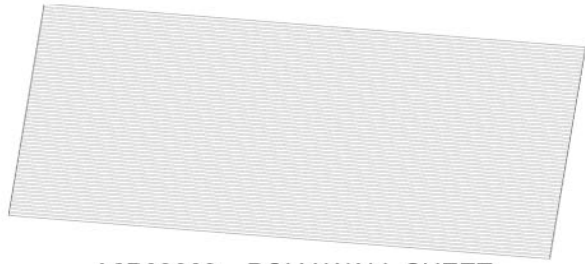

A6P00662 POLY WALL SHEET
(x6)



A6P00667 POLY CHANNEL
(x12)



A6P00690 DUST SEAL TAPE

NOTES:

1. INSTALL DUST TAPE ON TOP & BOTTOM ON EACH POLY SHEETING.
 - CUT (2) STRIPS OF DUST SEAL TAPE THE SAME WIDTH AS THE POLY SHEETING.
 - WRAP DUST SEAL TAPE ALONG EDGE OF POLY SHEETING WIDTH.
2. AFTER TAPE IS SECURE, PUSH CHANNEL ON OVER THE TOP OF THE TAPE.
 - CENTER CHANNEL ON SHEET WITH APPROXIMATELY 1" (25mm) CLEARANCE ON EACH SIDE OF POLY SHEET AS SHOWN.
3. REPEAT FOR ALL (6) WINDOWS.

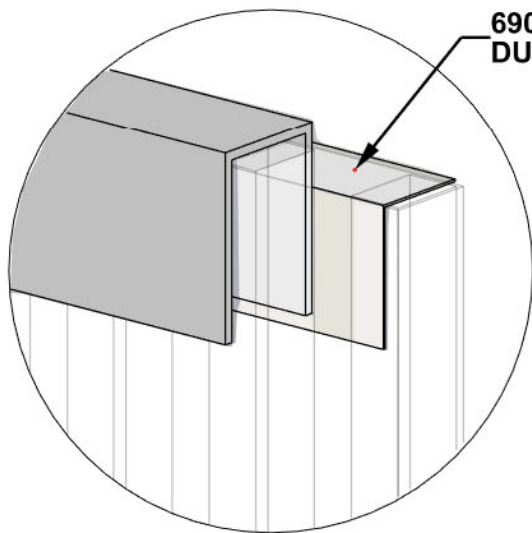

690 (x2)
DUST SEAL TAPE

667 (x1)
POLY CHANNEL

662 (x1)
POLY WALL SHEET

667 (x1)
POLY CHANNEL

STEP 45 - BACK WINDOWS

NOTES:

- INSERT WINDOW ASSEMBLY INTO PREVIOUSLY INSTALLED CHANNEL ON BOTH SIDES OF WINDOW.
- GENTLY SLIDE WINDOW DOWN UNTIL SEATED ON WINDOW LEDGE.
- IMPORTANT! ENSURE UV SIDE OF POLY SHEETING IS FACING OUTSIDE.
- SAFE TO REMOVE PROTECTIVE FILM FROM INSTALLED WINDOW.

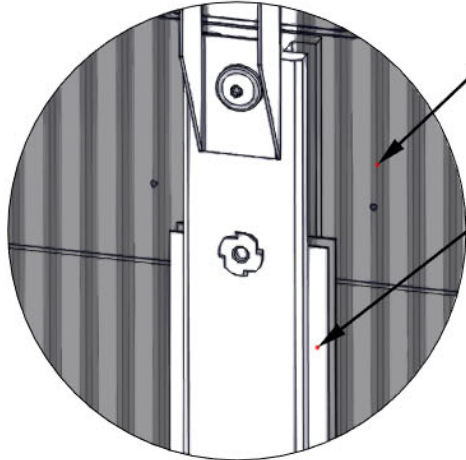

WINDOW ASSEMBLIES (6)
FROM STEP 44

POLY CHANNEL
FROM STEP 43

INSIDE VIEW

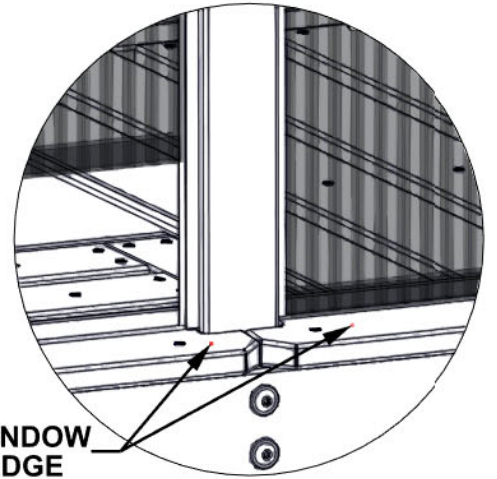

WINDOW
LEDGE

OUTSIDE VIEW

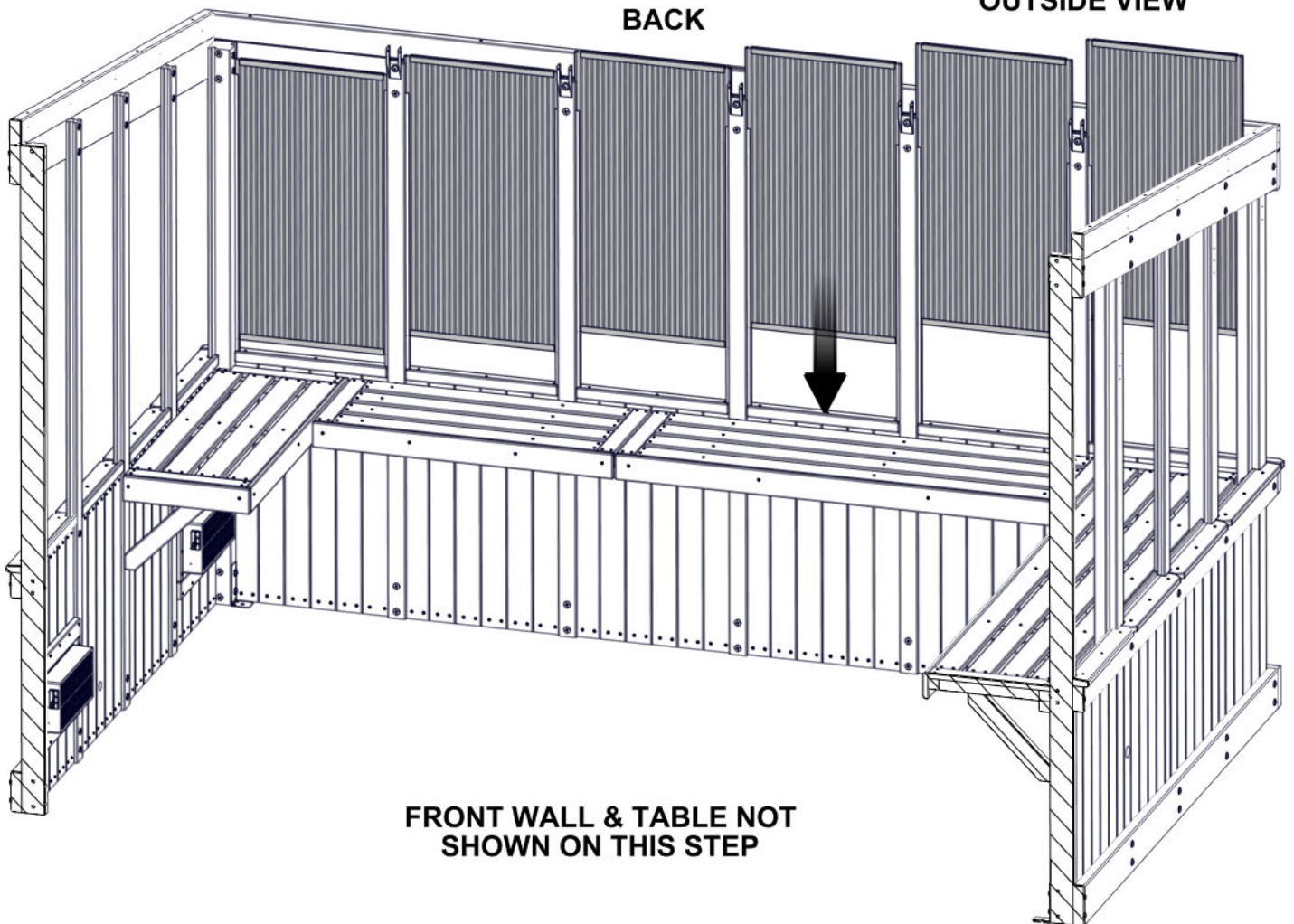

BACK

FRONT WALL & TABLE NOT
SHOWN ON THIS STEP

STEP 46 - BACK WINDOWS

Qty	PART NUMBER	DESCRIPTION
12	H100483	SCREW PFH 8 X 2 1/4 BLK



P03 WINDOW CAP BOARD - W4L18732
(x6) 1 7/16"x1 7/16"x19 7/8" (36x36x505)

NOTES:
ATTACH WINDOW CAP BOARD TO THE TOP OF THE WINDOW AS SHOWN.

P03 (x6)
WINDOW CAP BOARD

**CENTER WINDOW CAP BOARD
BETWEEN UPRIGHT/POSTS**

483 (x12)
SCREW - 2 1/4"

BACK

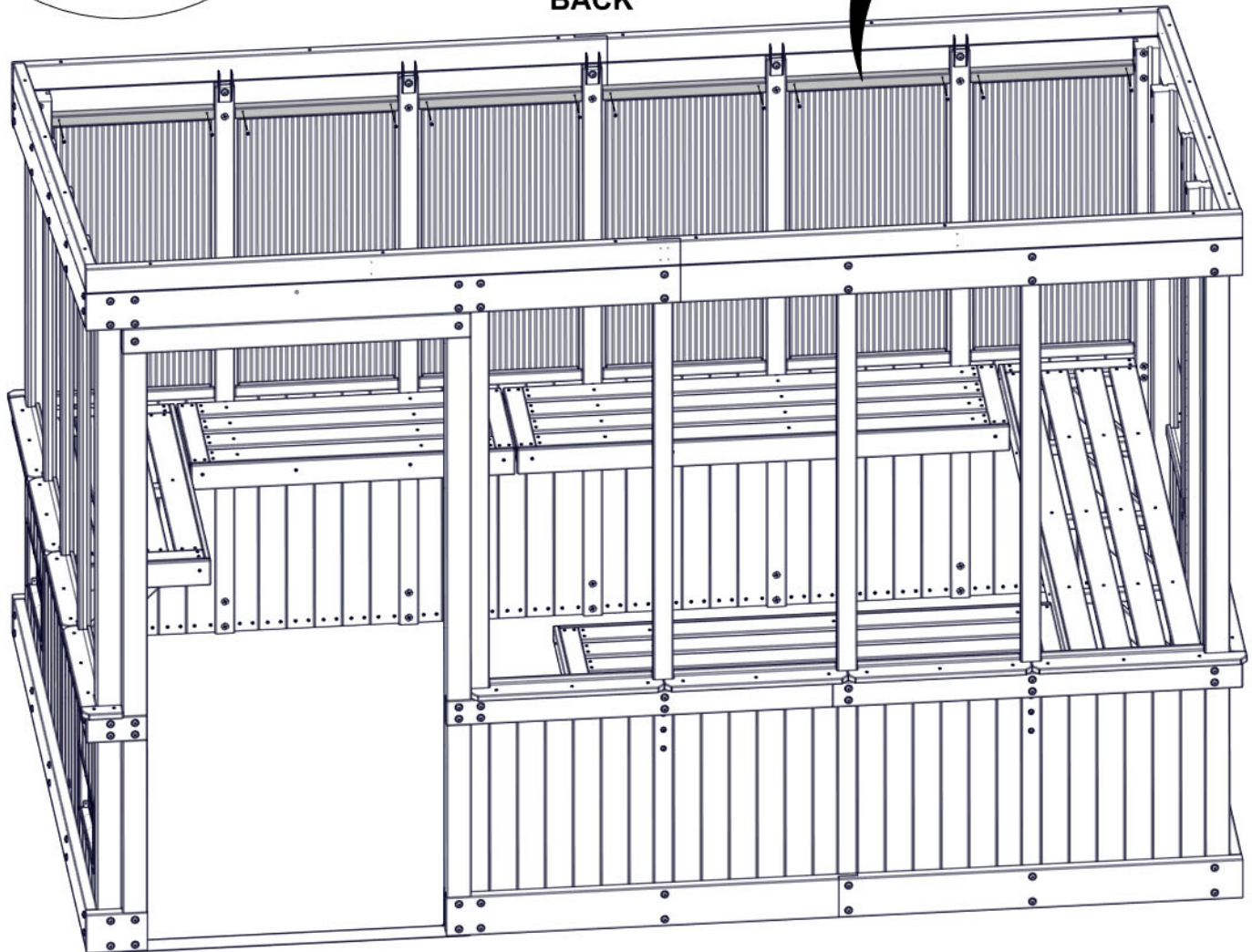

STEP 47 - LEFT WINDOWS

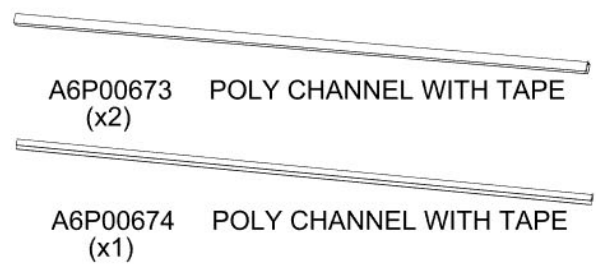
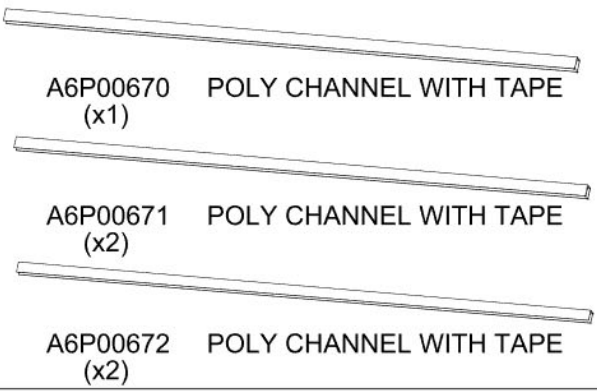

NOTES:
INSTALL (8) CHANNELS (2 PER WINDOW) BY REMOVING TAPE LINER & PUSH CHANNEL FIRMLY INTO WOOD GROOVES ON UPRIGHTS.

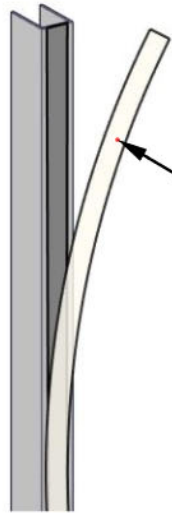

INSERT POLY CHANNEL INTO GROOVES STARTING AT THE WINDOW LEDGE & WORK UPWARDS.

POLY CHANNEL WILL COME WITH DOUBLE SIDED TAPE INSTALLED. REMOVE LINER BEFORE INSTALLATION.

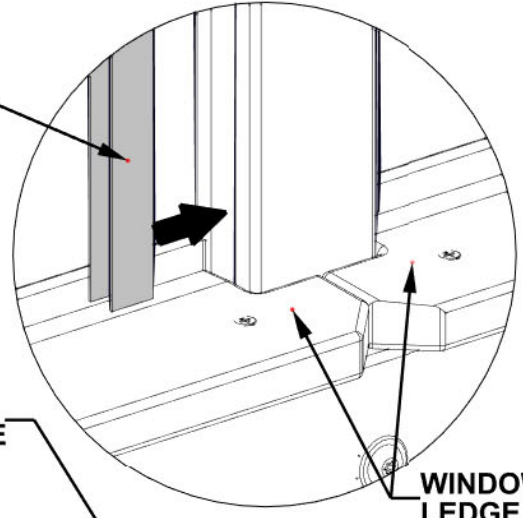

WINDOW LEDGE

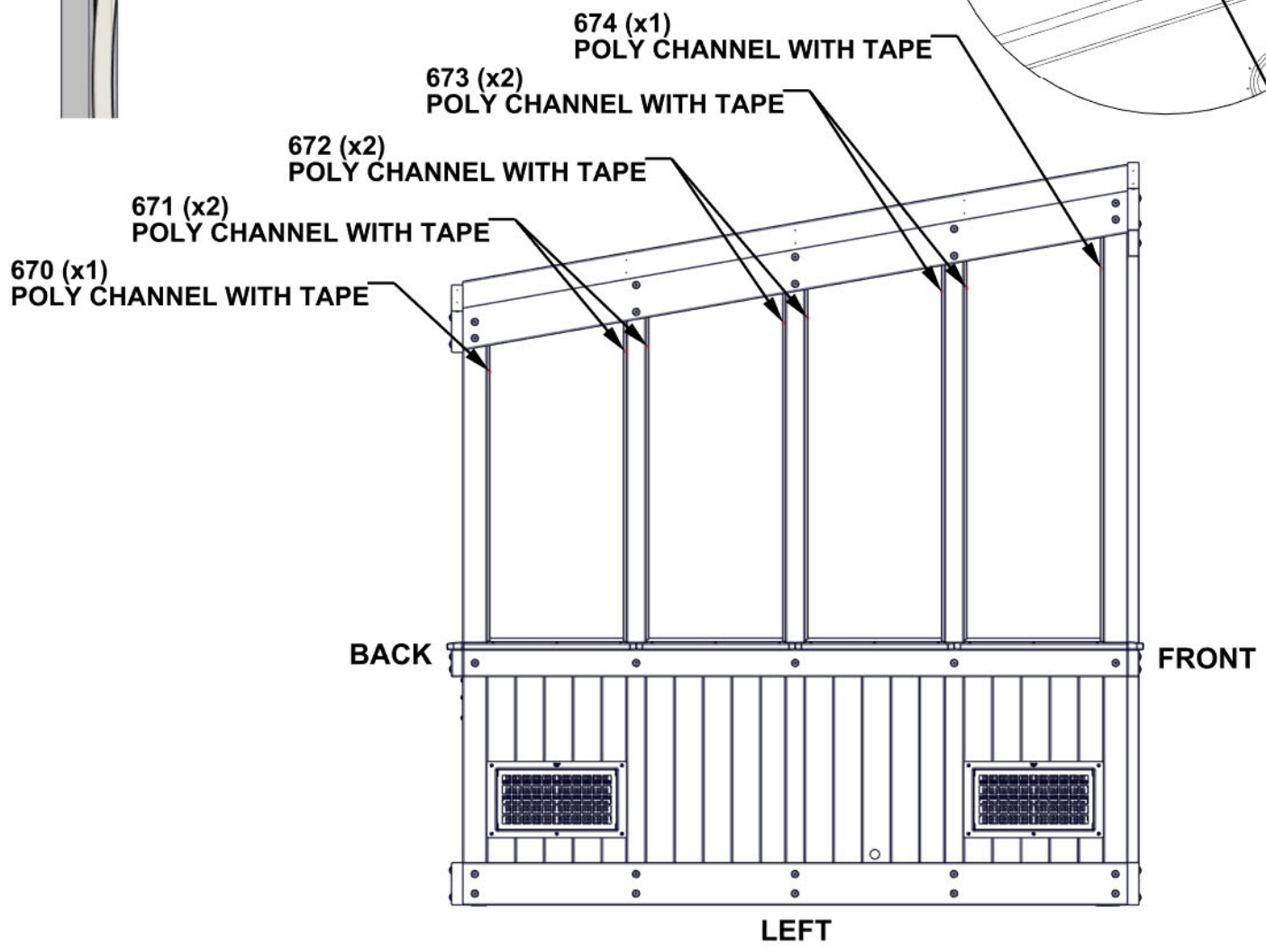

STEP 48A - LEFT WINDOWS

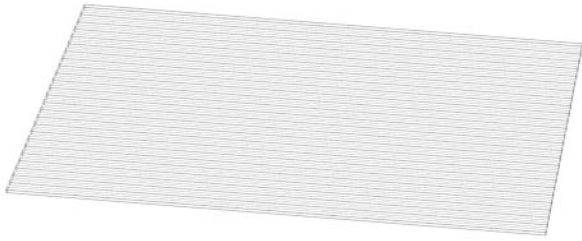

A6P00663 POLY WALL SHEET
(x1)

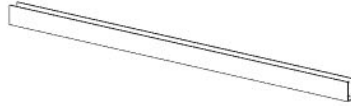

A6P00668 POLY CHANNEL
(x2)



A6P00690 DUST SEAL TAPE

NOTES:

1. INSTALL DUST TAPE ON TOP & BOTTOM ON EACH POLY SHEETING.
 - CUT (2) STRIPS OF DUST SEAL TAPE THE SAME WIDTH AS THE POLY SHEETING.
 - WRAP DUST SEAL TAPE ALONG EDGE OF POLY SHEETING WIDTH.
2. AFTER TAPE IS SECURE, PUSH CHANNEL ON OVER THE TOP OF THE TAPE.
 - CENTER CHANNEL ON SHEET WITH APPROXIMATELY 1" (25mm) CLEARANCE ON EACH SIDE OF POLY SHEET AS SHOWN.

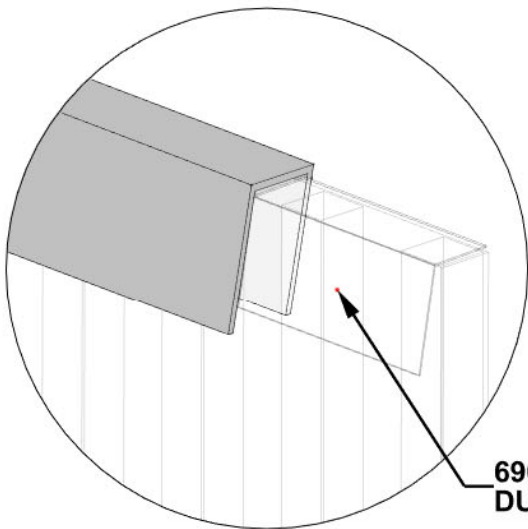

690 (x2)
DUST SEAL TAPE

668 (x1)
POLY CHANNEL

663 (x1)
POLY WALL SHEET

668 (x1)
POLY CHANNEL

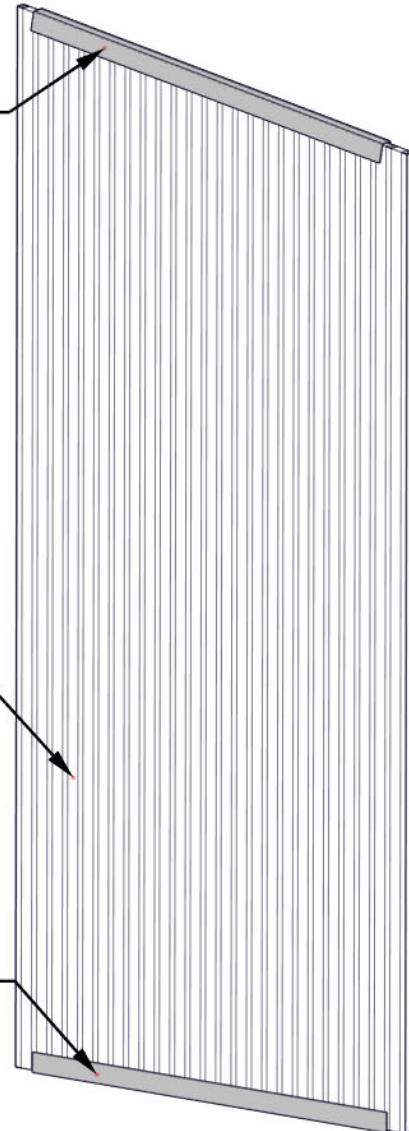

STEP 48B - LEFT WINDOWS

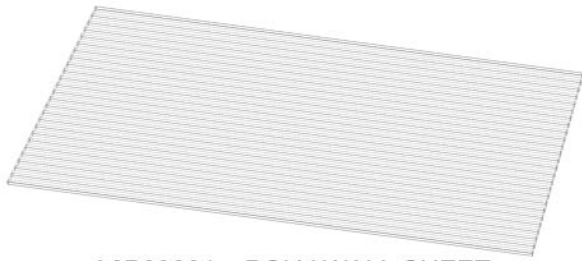

A6P00664 POLY WALL SHEET
(x1)



A6P00668 POLY CHANNEL
(x2)



A6P00690 DUST SEAL TAPE

NOTES:

1. INSTALL DUST TAPE ON TOP & BOTTOM ON EACH POLY SHEETING.
 - CUT (2) STRIPS OF DUST SEAL TAPE THE SAME WIDTH AS THE POLY SHEETING.
 - WRAP DUST SEAL TAPE ALONG EDGE OF POLY SHEETING WIDTH.
2. AFTER TAPE IS SECURE, PUSH CHANNEL ON OVER THE TOP OF THE TAPE.
 - CENTER CHANNEL ON SHEET WITH APPROXIMATELY 1" (25mm) CLEARANCE ON EACH SIDE OF POLY SHEET AS SHOWN.

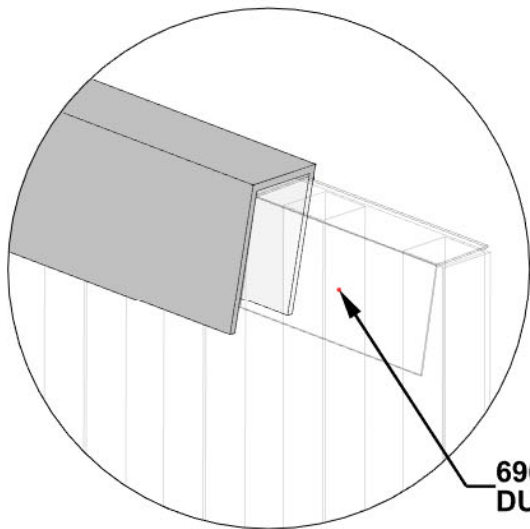

690 (x2)
DUST SEAL TAPE

668 (x1)
POLY CHANNEL

664 (x1)
POLY WALL SHEET

668 (x1)
POLY CHANNEL

STEP 48C - LEFT WINDOWS

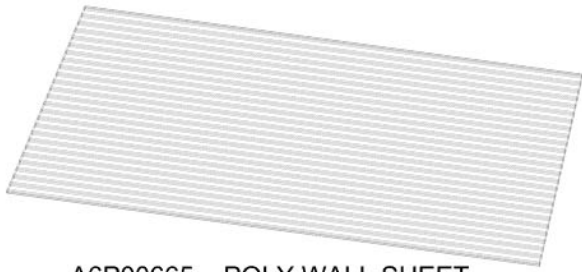

A6P00665 POLY WALL SHEET
(x1)



A6P00668 POLY CHANNEL
(x2)



A6P00690 DUST SEAL TAPE

NOTES:

1. INSTALL DUST TAPE ON TOP & BOTTOM ON EACH POLY SHEETING.
 - CUT (2) STRIPS OF DUST SEAL TAPE THE SAME WIDTH AS THE POLY SHEETING.
 - WRAP DUST SEAL TAPE ALONG EDGE OF POLY SHEETING WIDTH.
2. AFTER TAPE IS SECURE, PUSH CHANNEL ON OVER THE TOP OF THE TAPE.
 - CENTER CHANNEL ON SHEET WITH APPROXIMATELY 1" (25mm) CLEARANCE ON EACH SIDE OF POLY SHEET AS SHOWN.

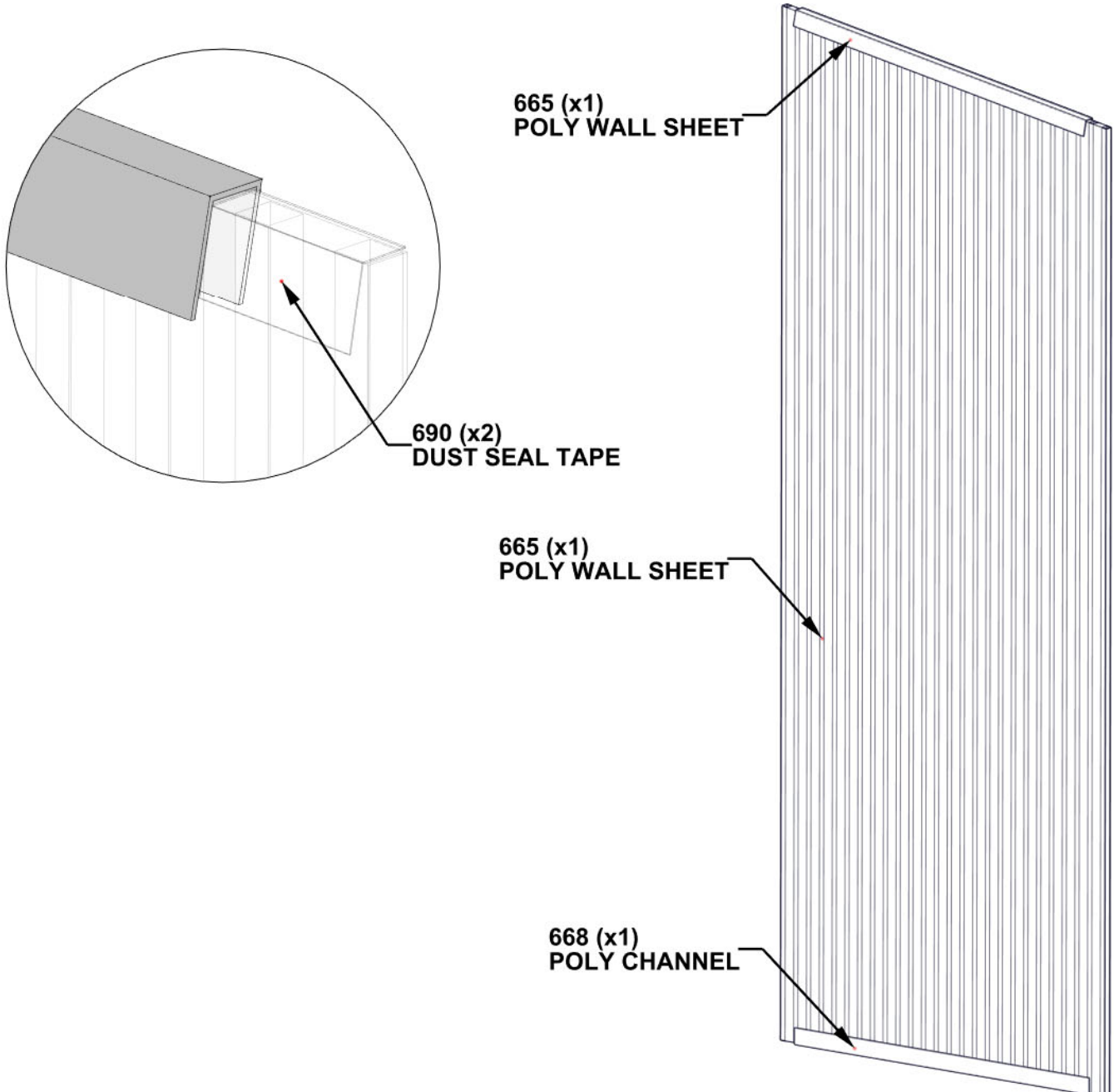

STEP 48D - LEFT WINDOWS

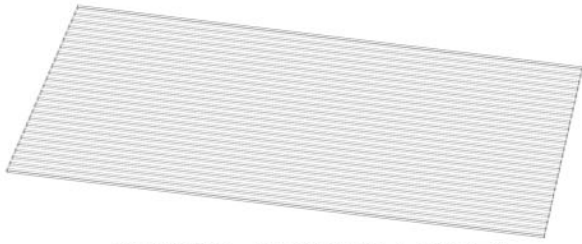

A6P00666 POLY WALL SHEET
(x1)



A6P00668 POLY CHANNEL
(x2)



A6P00690 DUST SEAL TAPE

NOTES:

1. INSTALL DUST TAPE ON TOP & BOTTOM ON EACH POLY SHEETING.
 - CUT (2) STRIPS OF DUST SEAL TAPE THE SAME WIDTH AS THE POLY SHEETING.
 - WRAP DUST SEAL TAPE ALONG EDGE OF POLY SHEETING WIDTH.
2. AFTER TAPE IS SECURE, PUSH CHANNEL ON OVER THE TOP OF THE TAPE.
 - CENTER CHANNEL ON SHEET WITH APPROXIMATELY 1" (25mm) CLEARANCE ON EACH SIDE OF POLY SHEET AS SHOWN.

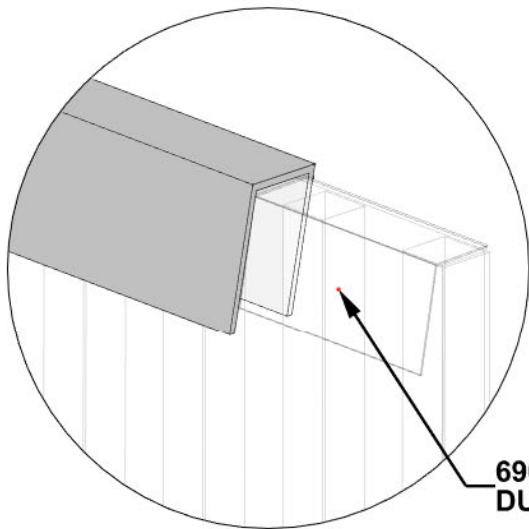

690 (x2)
DUST SEAL TAPE

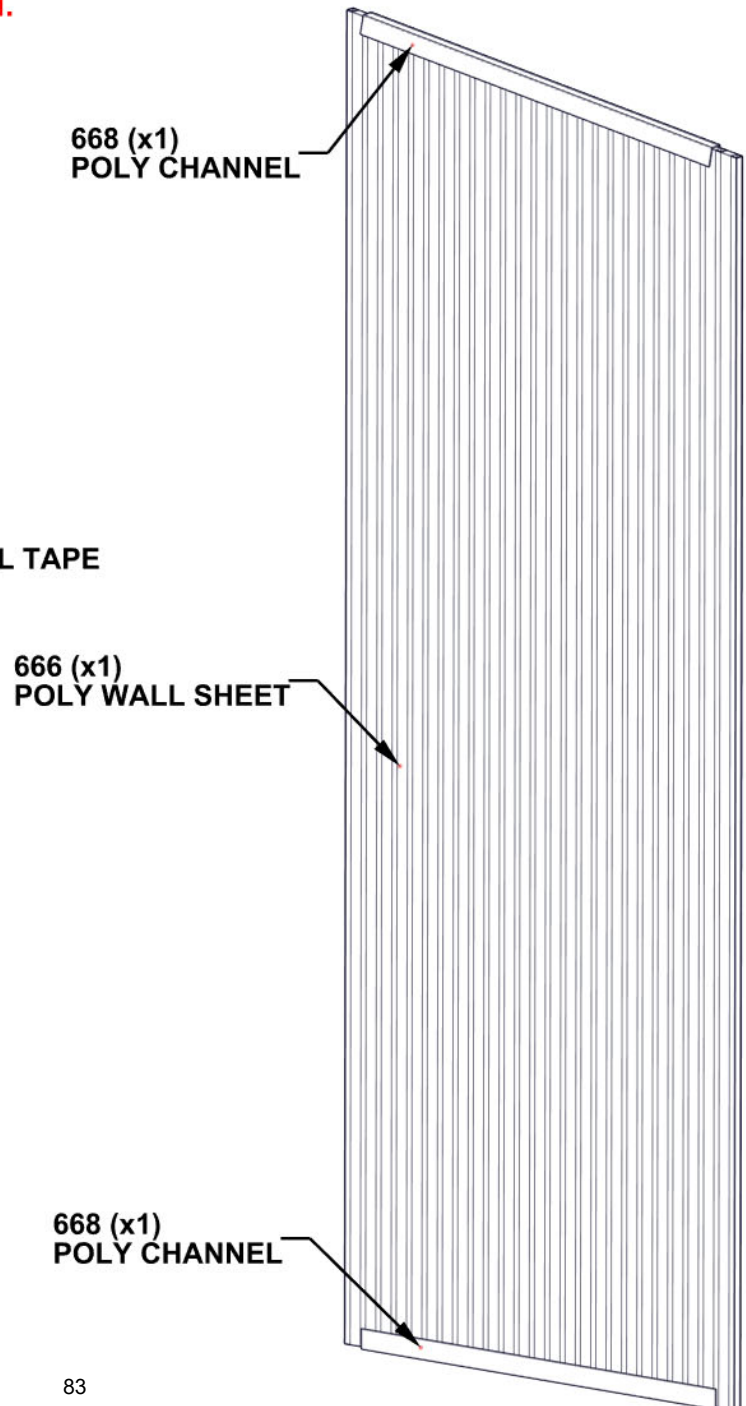

668 (x1)
POLY CHANNEL

666 (x1)
POLY WALL SHEET

668 (x1)
POLY CHANNEL

STEP 49 - LEFT WINDOWS

NOTES:

- INSERT WINDOW ASSEMBLY INTO PREVIOUSLY INSTALLED CHANNEL ON BOTH SIDES OF WINDOW.
- GENTLY SLIDE WINDOW DOWN UNTIL SEATED ON WINDOW LEDGE.
- IMPORTANT! ENSURE UV SIDE OF POLY SHEETING IS FACING OUTSIDE.
- SAFE TO REMOVE PROTECTIVE FILM FROM INSTALLED WINDOW.

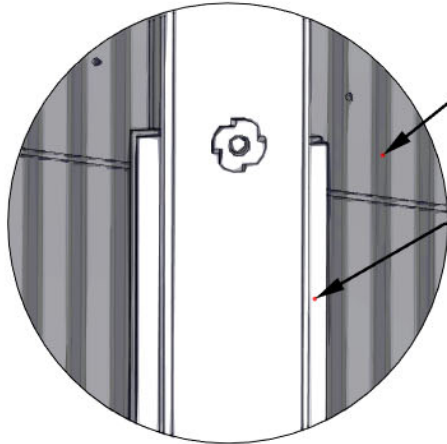

WINDOW ASSEMBLIES (4)
FROM STEPS 48A-48D

POLY CHANNELS
FROM STEP 47

INSIDE VIEW

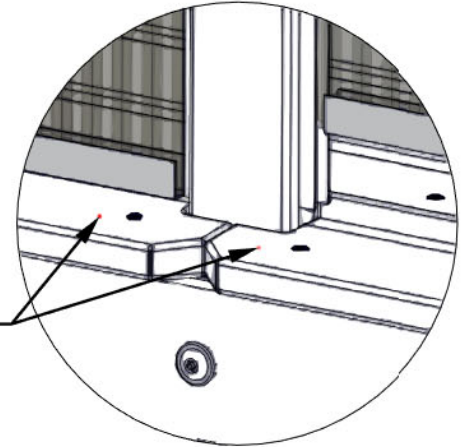

WINDOW
LEDGE

OUTSIDE VIEW

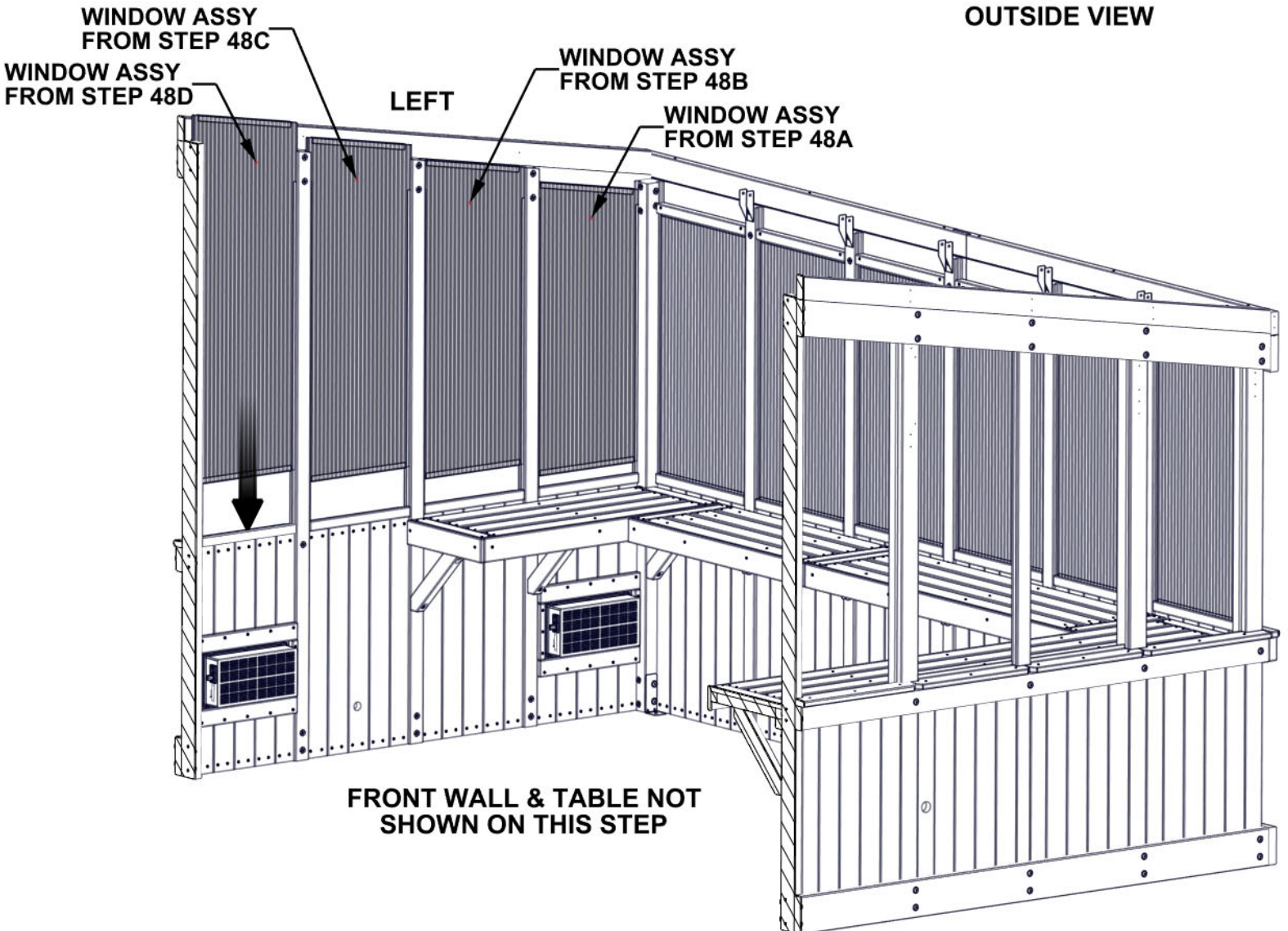

WINDOW ASSY
FROM STEP 48C

WINDOW ASSY
FROM STEP 48D

LEFT

WINDOW ASSY
FROM STEP 48B

WINDOW ASSY
FROM STEP 48A

FRONT WALL & TABLE NOT
SHOWN ON THIS STEP

STEP 50 - LEFT WINDOWS

Qty	PART NUMBER	DESCRIPTION
8	H100483	SCREW PFH 8 X 2 1/4 BLK



P06 WINDOW CAP BOARD - W4L18735
(x4) 1 7/16"x1 7/16"x17 7/8" (36x36x454)

NOTES:
ATTACH WINDOW CAP BOARD TO THE TOP OF THE WINDOW AS SHOWN.

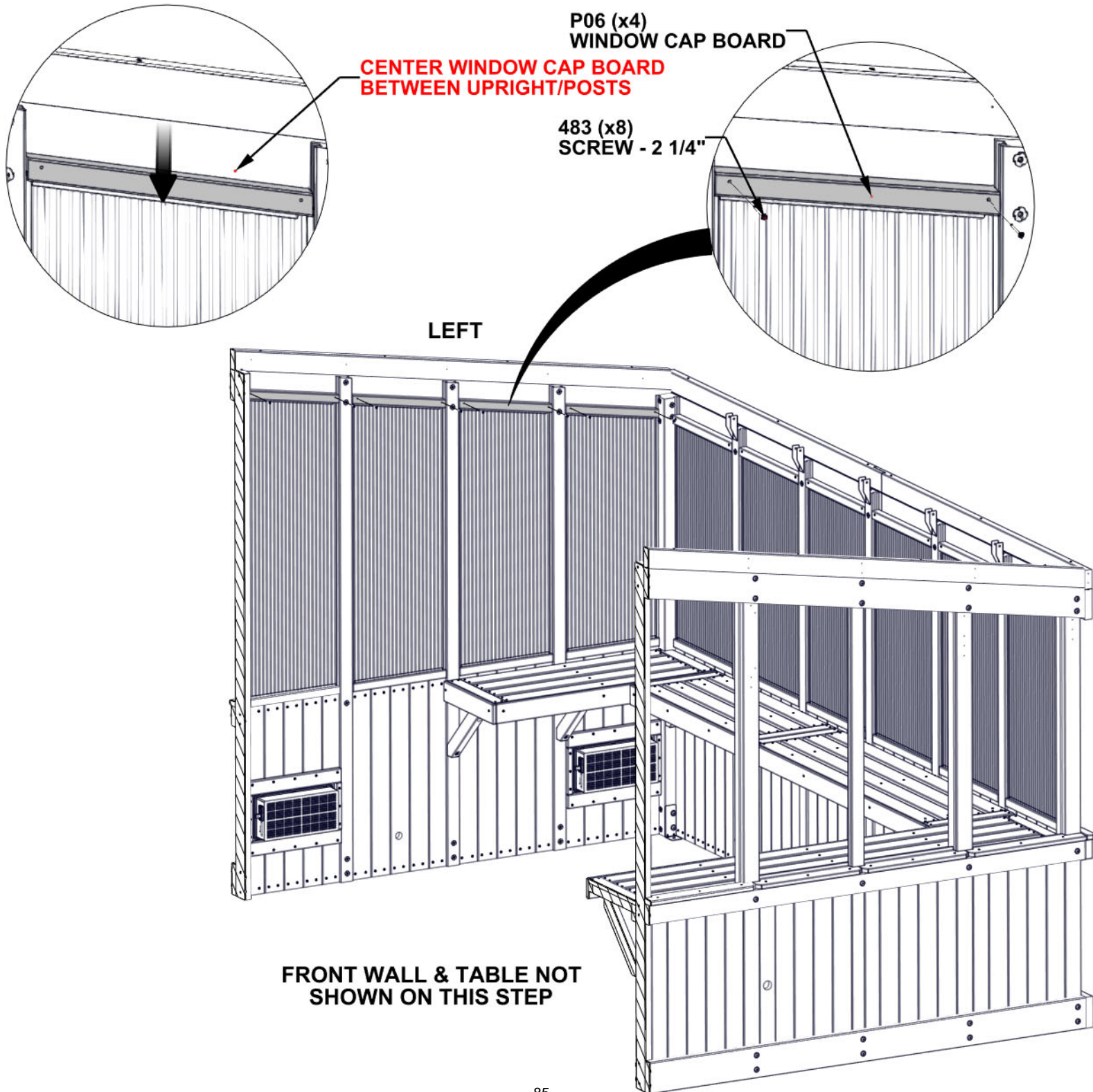

STEP 51 - RIGHT WINDOWS

A6P00709 POLY CHANNEL WITH TAPE
(x4)

A6P00672 POLY CHANNEL WITH TAPE
(x2)

A6P00671 POLY CHANNEL WITH TAPE
(x1)

A6P00673 POLY CHANNEL WITH TAPE
(x1)

**INSERT POLY CHANNELS (671, 672, & 673)
INTO GROOVE STARTING AT THE WINDOW
LEDGE & WORK UPWARDS**

**POLY CHANNEL WILL COME WITH DOUBLE
SIDED TAPE INSTALLED. REMOVE LINER
BEFORE INSTALLATION.**

709 (x2)
POLY CHANNEL WITH TAPE

673 (x1)
POLY CHANNEL WITH TAPE

672 (x2)
POLY CHANNEL WITH TAPE

671 (x1)
POLY CHANNEL WITH TAPE

709 (x2)
POLY CHANNEL WITH TAPE

**INSERT POLY CHANNEL (709) INTO
GROOVE STARTING AT THE BOTTOM OF
INTERIOR POSTS AND WORK UPWARDS**

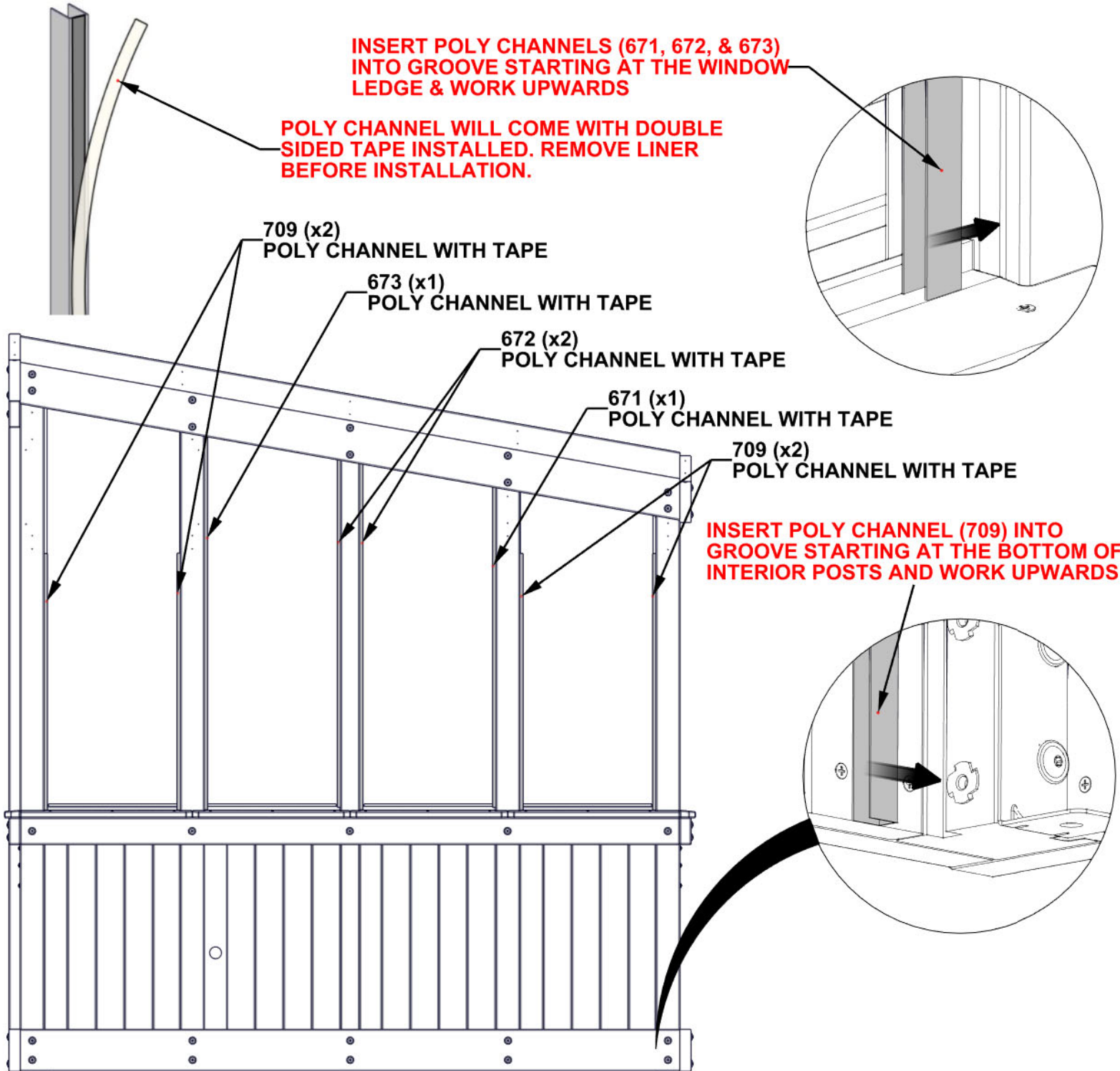

RIGHT

STEP 52 - RIGHT WINDOWS

Qty	PART NUMBER	DESCRIPTION
4	H100387	SCREW PFH 8 X 1 1/4 BLK



N05 WINDOW STOP - W4L18811
 (x2) 5/8"x2 3/8"x16 9/16" (16x60x420)

**NOTES:
 ALIGN PILOT HOLES
 & ATTACH AS SHOWN**

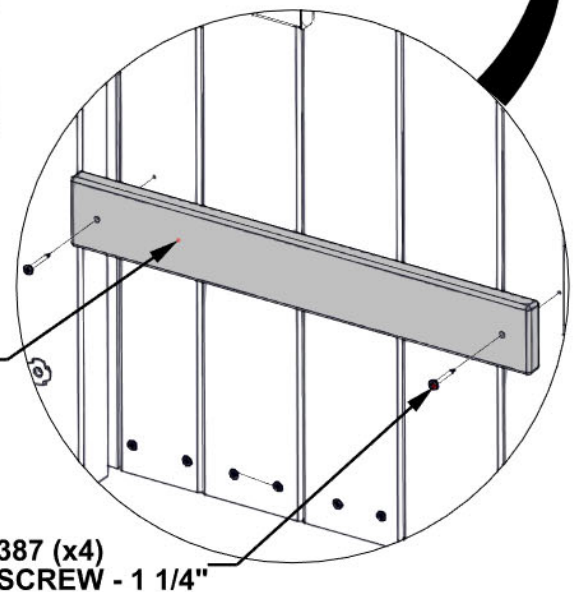
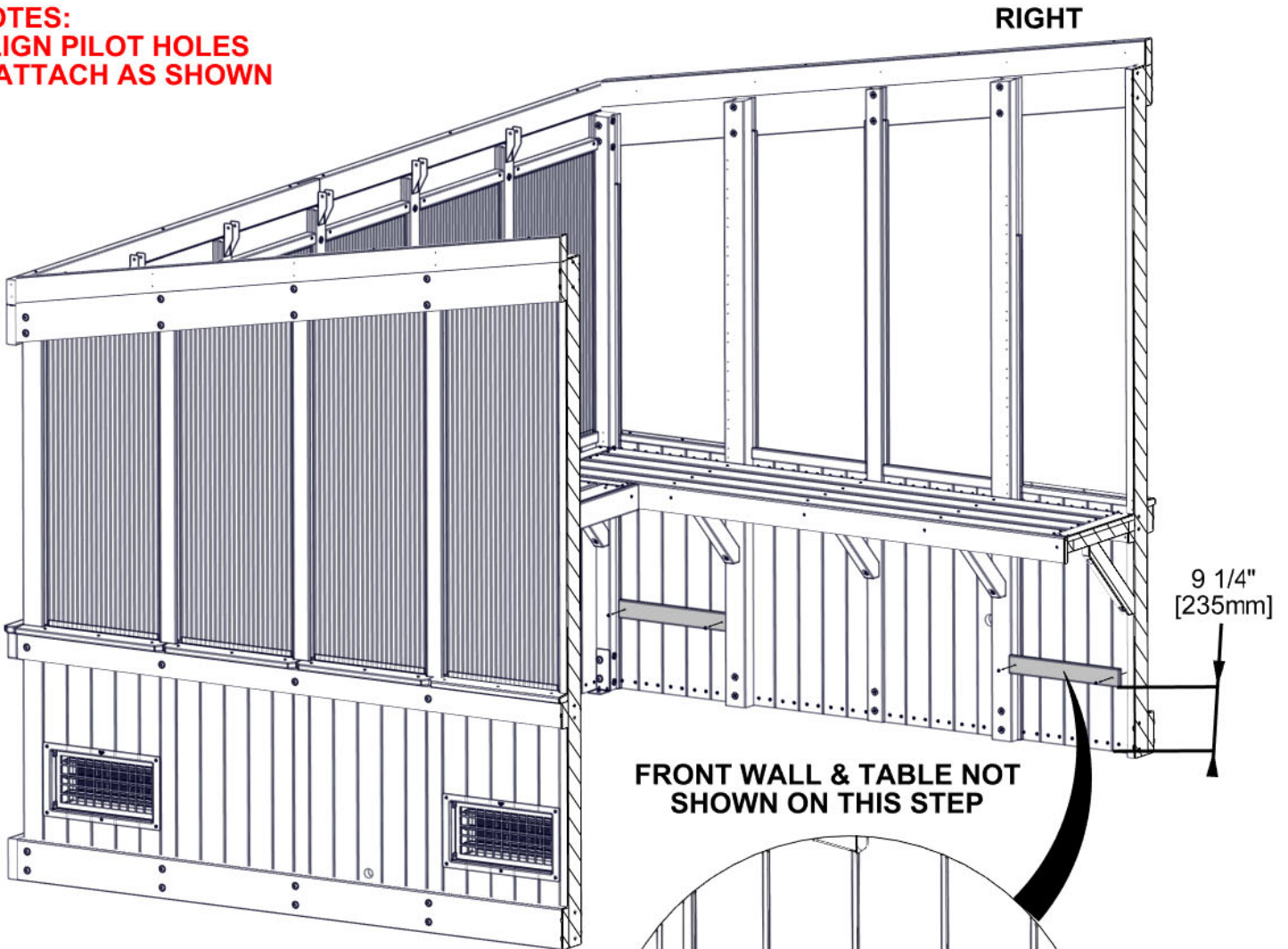

N05 (x2)
 WINDOW STOP

387 (x4)
 SCREW - 1 1/4"

STEP 53 - RIGHT WINDOWS

Qty	PART NUMBER	DESCRIPTION
16	H101205	SCREW PWH 8 X 1/5 X 3/4 BLK

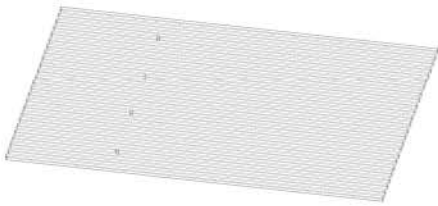

A6P00675 POLY WALL SHEET (x2)

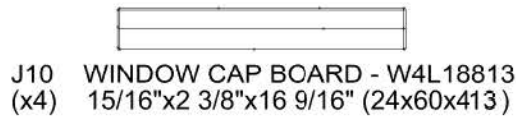

J10 WINDOW CAP BOARD - W4L18813 (x4) 15/16"x2 3/8"x16 9/16" (24x60x413)



A6P00713 POLY SHEET CHANNEL (x4)



A6P00690 DUST SEAL TAPE

NOTES:

1. APPLY DUST TAPE & CHANNEL:

- CUT (2) STRIPS OF DUST SEAL TAPE THE SAME WIDTH AS THE POLY SHEETING.
- WRAP DUST SEAL TAPE ALONG EDGE OF POLY SHEETING WIDTH.
- AFTER TAPE IS SECURE, PUSH CHANNEL ON OVER THE TOP OF THE TAPE.
- CENTER CHANNEL ON SHEET WITH APPROXIMATELY 3/4" (20mm) CLEARANCE ON EACH SIDE OF POLY SHEET AS SHOWN.
- REPEAT ON THE BOTTOM SIDE OF POLY SHEETING.

2. ATTACH WINDOW CAP BOARDS, AS SHOWN.

3. REPEAT FOR SECOND WINDOW ASSEMBLY.

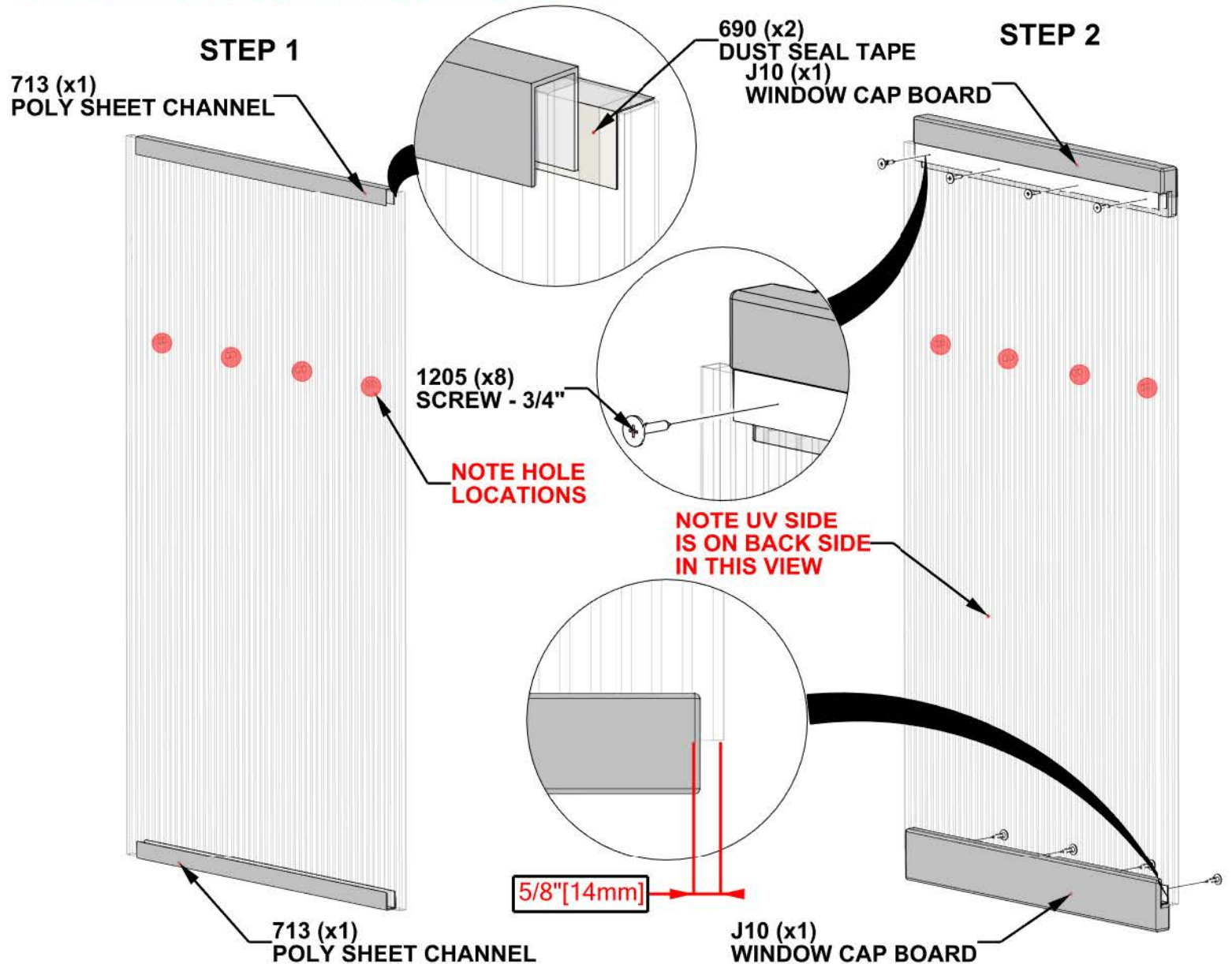

STEP 54 - RIGHT WINDOWS

NOTES:

- INSERT WINDOW ASSEMBLY INTO PREVIOUSLY INSTALLED CHANNEL ON BOTH SIDES OF WINDOW.
- GENTLY SLIDE WINDOW DOWN TO THE CLOSED POSITION.
- IMPORTANT! ENSURE UV SIDE OF POLY SHEETING IS FACING OUTSIDE.
- SAFE TO REMOVE PROTECTIVE FILM FROM INSTALLED WINDOW.

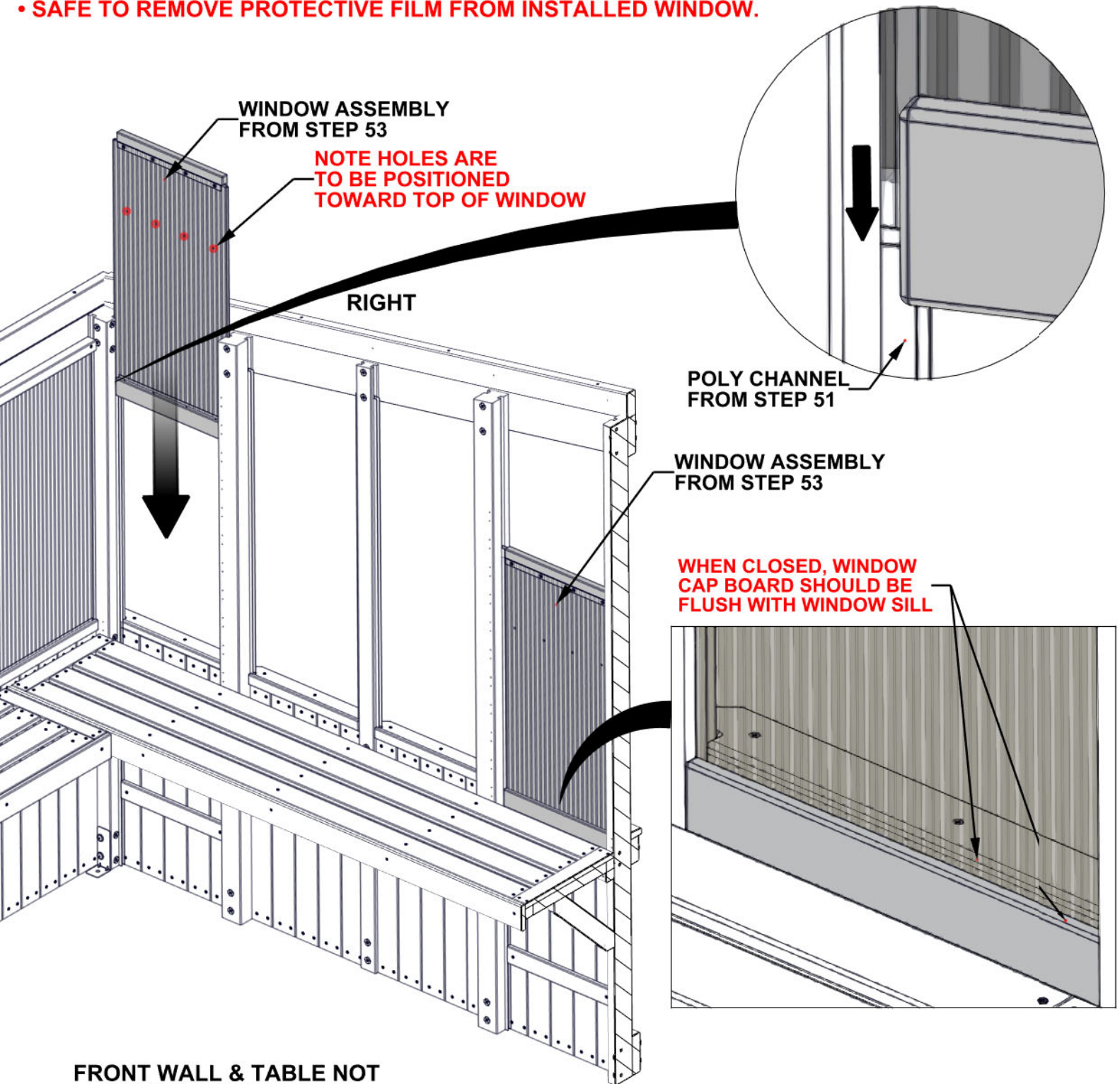

WINDOW ASSEMBLY FROM STEP 53

NOTE HOLES ARE TO BE POSITIONED TOWARD TOP OF WINDOW

RIGHT

POLY CHANNEL FROM STEP 51

WINDOW ASSEMBLY FROM STEP 53

WHEN CLOSED, WINDOW CAP BOARD SHOULD BE FLUSH WITH WINDOW SILL

FRONT WALL & TABLE NOT SHOWN ON THIS STEP

STEP 55 - RIGHT WINDOWS

Qty	PART NUMBER	DESCRIPTION
8	H100400	WASHER LOCK EXT 8X15 BLK
8	H100404	NUT BARREL WH 1/4 X 5/8 BLK
8	H100405	WASHER LOCK EXT 6X15 BLK
8	H100488	BOLT WH 1/4 X 2 BLK



J08 WINDOW HANDLE - W4L18810
(x4) 15/16"x2 3/8"x15 1/2" (24x60x394)

NOTES:
LINE UP WINDOW HANDLE WITH HOLES IN POLY SHEETING

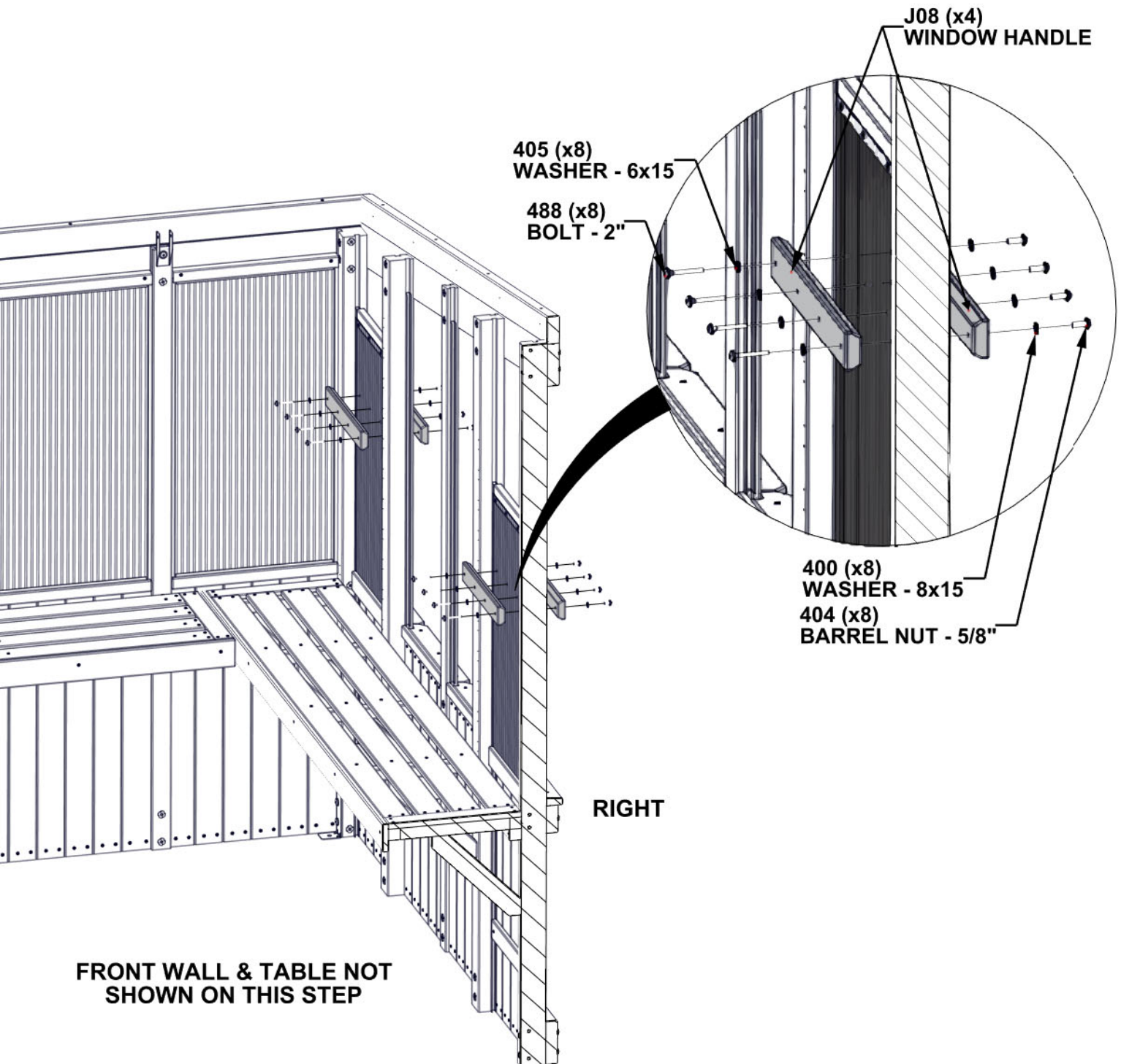

STEP 56 - RIGHT WINDOWS

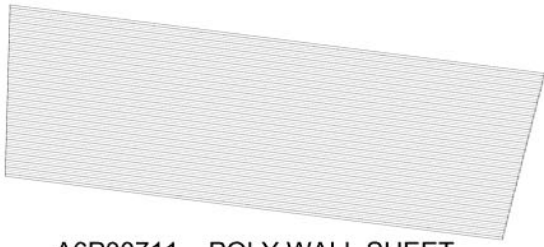

A6P00711 POLY WALL SHEET
(x1)

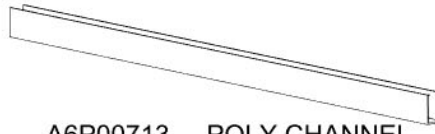

A6P00713 POLY CHANNEL
(x2)



A6P00690 DUST TAPE

NOTES:

1. INSTALL DUST TAPE ON TOP & BOTTOM ON EACH POLY SHEETING.
 - CUT (2) STRIPS OF DUST SEAL TAPE THE SAME WIDTH AS THE POLY SHEETING.
 - WRAP DUST SEAL TAPE ALONG EDGE OF POLY SHEETING WIDTH.
2. AFTER TAPE IS SECURE, PUSH CHANNEL ON OVER THE TOP OF THE TAPE.
 - CENTER CHANNEL ON SHEET WITH APPROXIMATELY 1" (25mm) CLEARANCE ON EACH SIDE OF POLY SHEET AS SHOWN.

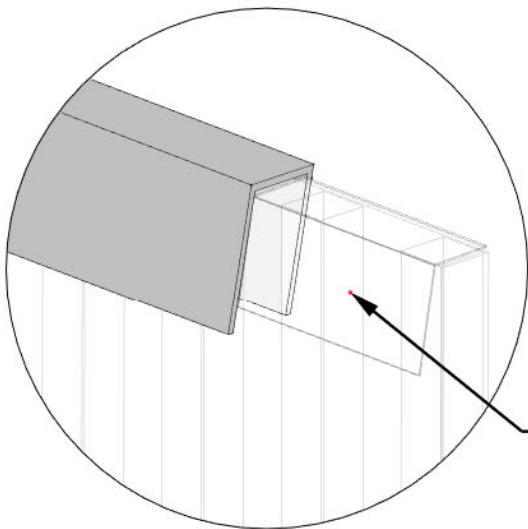

690 (x2)
DUST SEAL TAPE

713 (x1)
POLY CHANNEL

711 (x1)
POLY WALL SHEET

713 (x1)
POLY CHANNEL

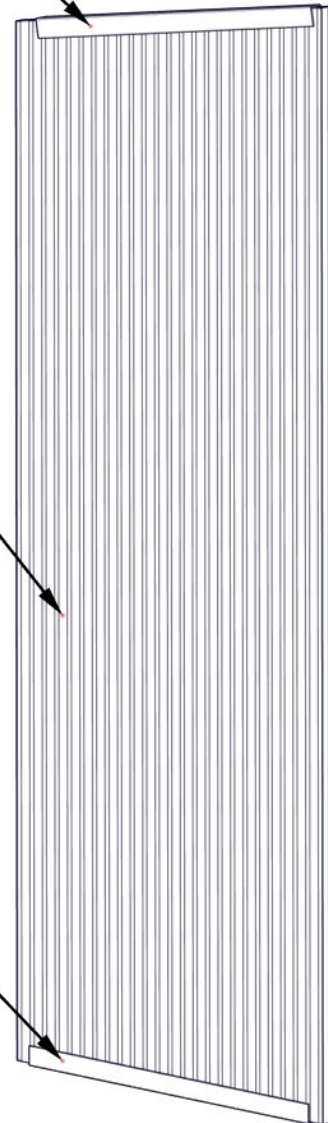

STEP 57 - RIGHT WINDOWS

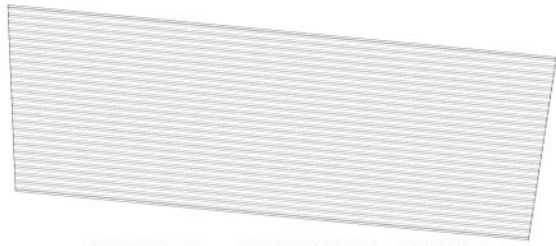

A6P00712 POLY WALL SHEET
(x1)



A6P00713 POLY CHANNEL
(x2)



A6P00690 DUST TAPE

NOTES:

1. INSTALL DUST TAPE ON TOP & BOTTOM ON EACH POLY SHEETING.
 - CUT (2) STRIPS OF DUST SEAL TAPE THE SAME WIDTH AS THE POLY SHEETING.
 - WRAP DUST SEAL TAPE ALONG EDGE OF POLY SHEETING WIDTH.
2. AFTER TAPE IS SECURE, PUSH CHANNEL ON OVER THE TOP OF THE TAPE.
 - CENTER CHANNEL ON SHEET WITH APPROXIMATELY 1" (25mm) CLEARANCE ON EACH SIDE OF POLY SHEET AS SHOWN.

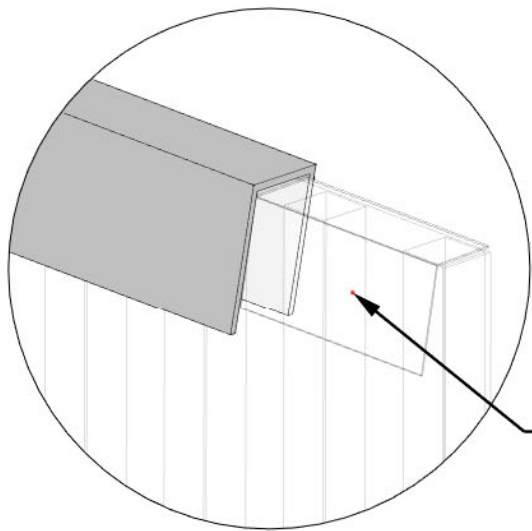

690 (x2)
DUST SEAL TAPE

713 (x1)
POLY CHANNEL

712 (x1)
POLY WALL SHEET

713 (x1)
POLY CHANNEL

STEP 58 - RIGHT WINDOWS

NOTES:

- INSERT WINDOW ASSEMBLY INTO PREVIOUSLY INSTALLED CHANNEL ON BOTH SIDES OF WINDOW.
- GENTLY SLIDE WINDOW DOWN UNTIL SEATED ON WINDOW LEDGE.
- IMPORTANT! ENSURE UV SIDE OF POLY SHEETING IS FACING OUTSIDE.
- SAFE TO REMOVE PROTECTIVE FILM FROM INSTALLED WINDOW.

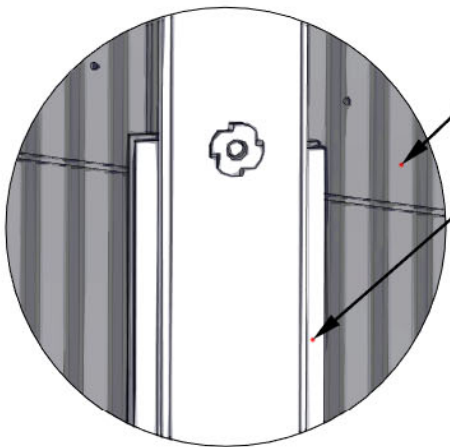

INSIDE VIEW

WINDOW ASSEMBLIES (2)
FROM STEPS 56-57

POLY CHANNELS
FROM STEP 51

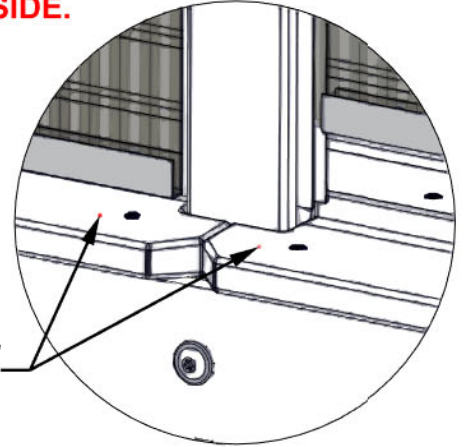

WINDOW
LEDGE

OUTSIDE VIEW

WINDOW ASSY
FROM STEP 56

RIGHT

WINDOW ASSY
FROM STEP 57

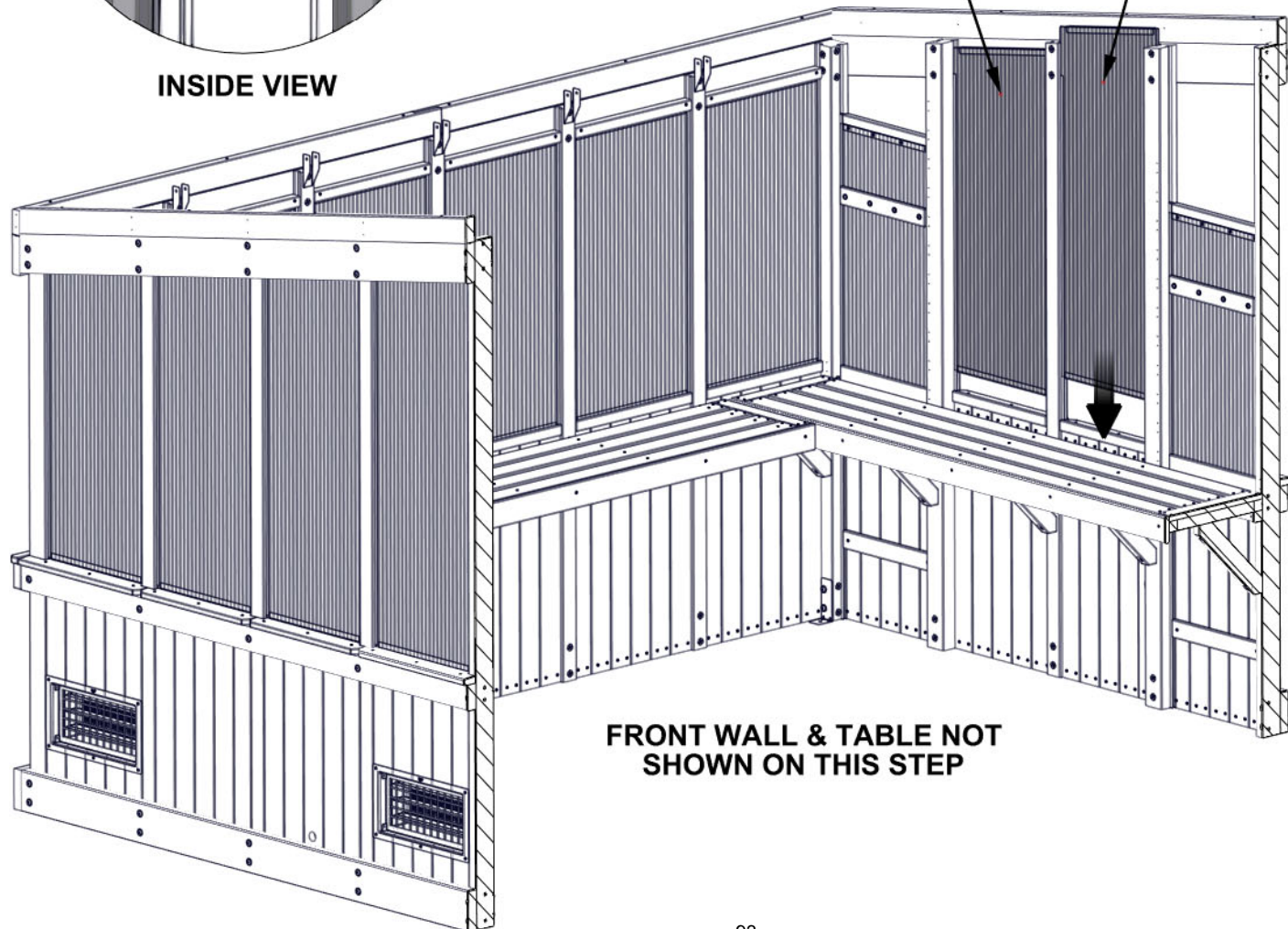

FRONT WALL & TABLE NOT
SHOWN ON THIS STEP

STEP 59 - RIGHT WINDOWS

Qty	PART NUMBER	DESCRIPTION
4	H100483	SCREW PFH 8 X 2 1/4 BLK



P05 WINDOW CAP BOARD - W4L18734
(x2) 1 7/16"x1 7/16"x17 9/16" (36x36x446)

NOTES:
ATTACH WINDOW CAP BOARD TO THE TOP OF THE WINDOW AS SHOWN.

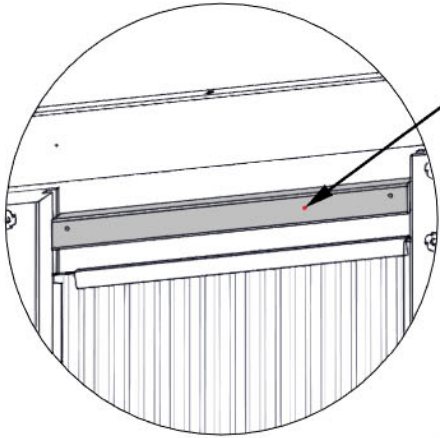

CENTER WINDOW CAP BOARD BETWEEN UPRIGHTS

483 (x4)
SCREW - 2 1/4"

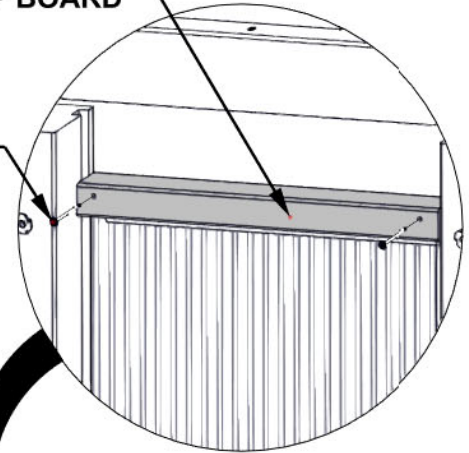

RIGHT

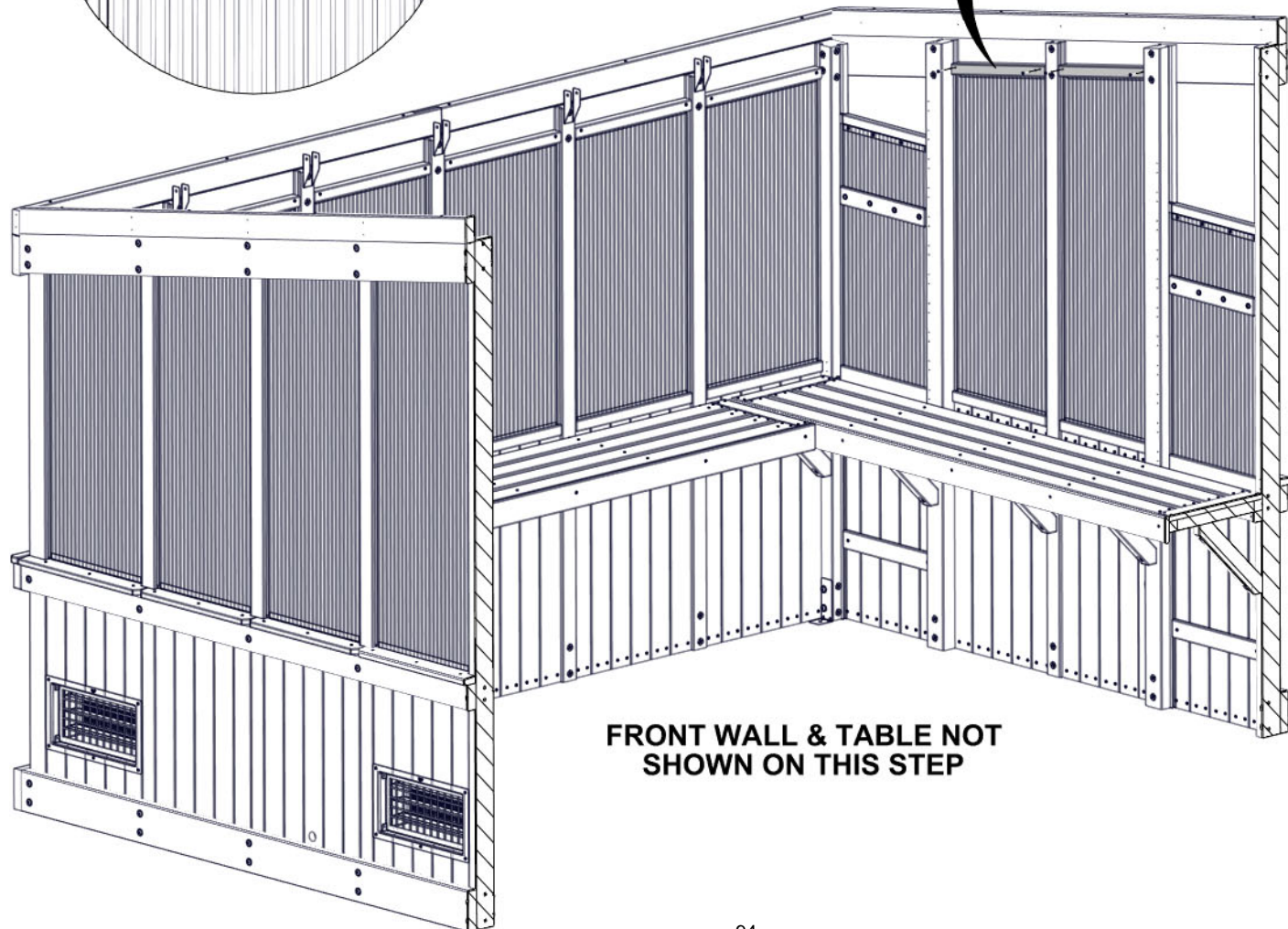

FRONT WALL & TABLE NOT SHOWN ON THIS STEP

STEP 60 - RIGHT WALL

Qty	PART NUMBER	DESCRIPTION
6	H100483	SCREW PFH 8 X 2 1/4 BLK

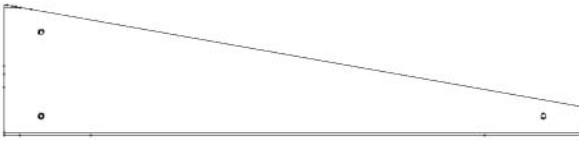

D03 HEADER - W4L18697
(x2) 1 7/16"x5 1/4"x23 1/4" (36x134x591)

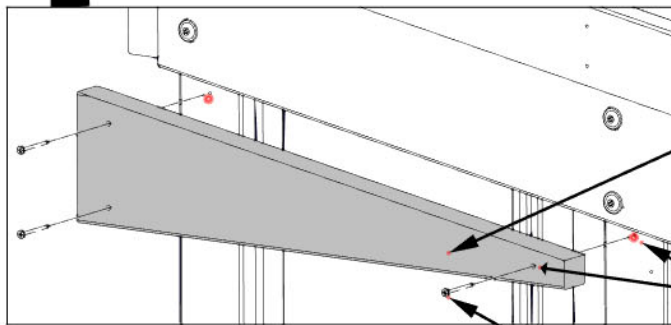
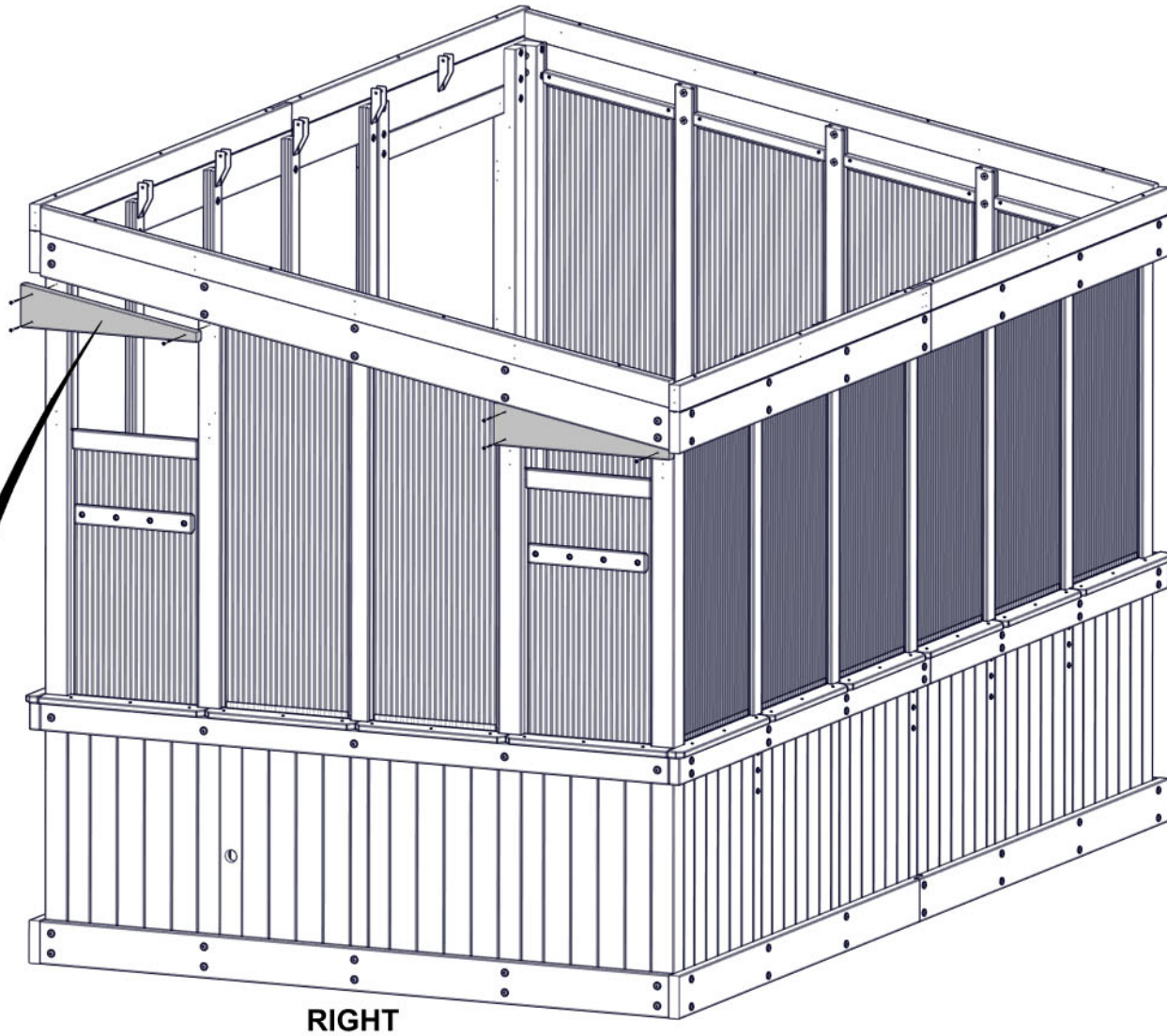

D03 (x2)
HEADER

**ALIGN HEADERS WITH
PILOT HOLES BEFORE
INSERTING SCREWS**

483 (x6)
SCREW - 2 1/4"

STEP 61 - RIGHT WALL

Qty	PART NUMBER	DESCRIPTION
4	H100483	SCREW PFH 8 X 2 1/4 BLK

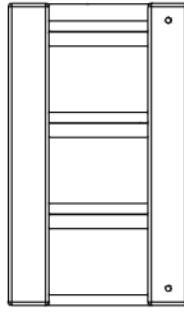
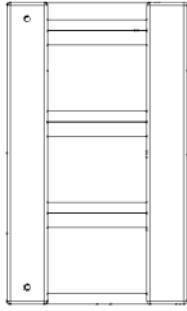

FT01 FAN TRIM ASSEMBLY - W2A03987
(x1) 1 7/16"x6 5/16"x10 9/16" (36x160x268)

FT02 FAN TRIM ASSEMBLY - W2A03988
(x1) 1 7/16"x6 5/16"x10 9/16" (36x160x268)

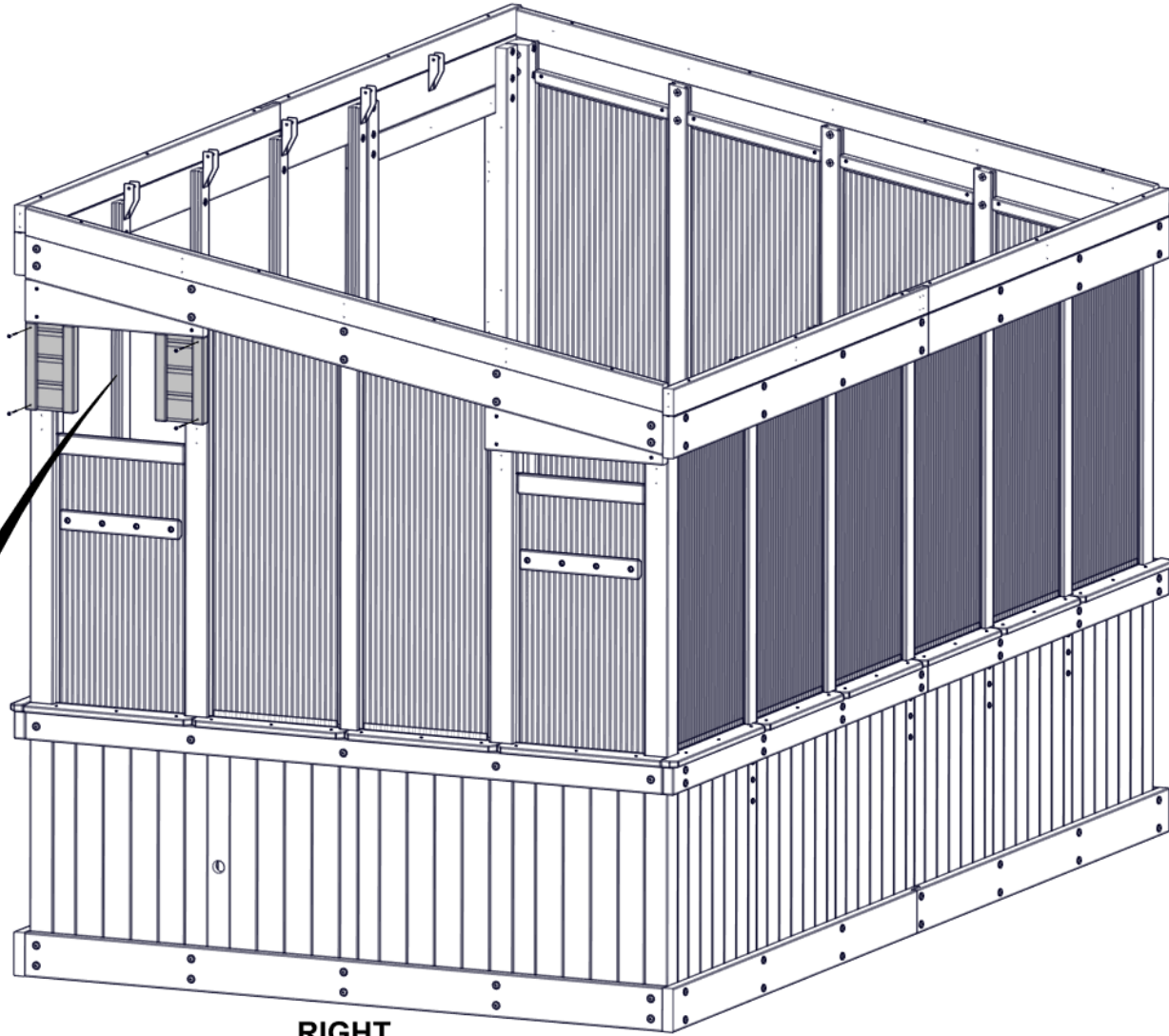

RIGHT



**ALIGN FAN TRIM ASSEMBLIES
WITH PILOT HOLES BEFORE
INSERTING SCREWS**

483 (x4)
SCREW - 2 1/4"

FT02 (x1)
FAN TRIM ASSEMBLY

FT01 (x1)
FAN TRIM ASSEMBLY

STEP 62 - RIGHT WALL

Qty	PART NUMBER	DESCRIPTION
8	H100483	SCREW PFH 8 X 2 1/4 BLK



E05 WINDOW TRIM - W4L18698
(x2) 1 7/16"x3 3/8"x23 1/4" (36x86x591)

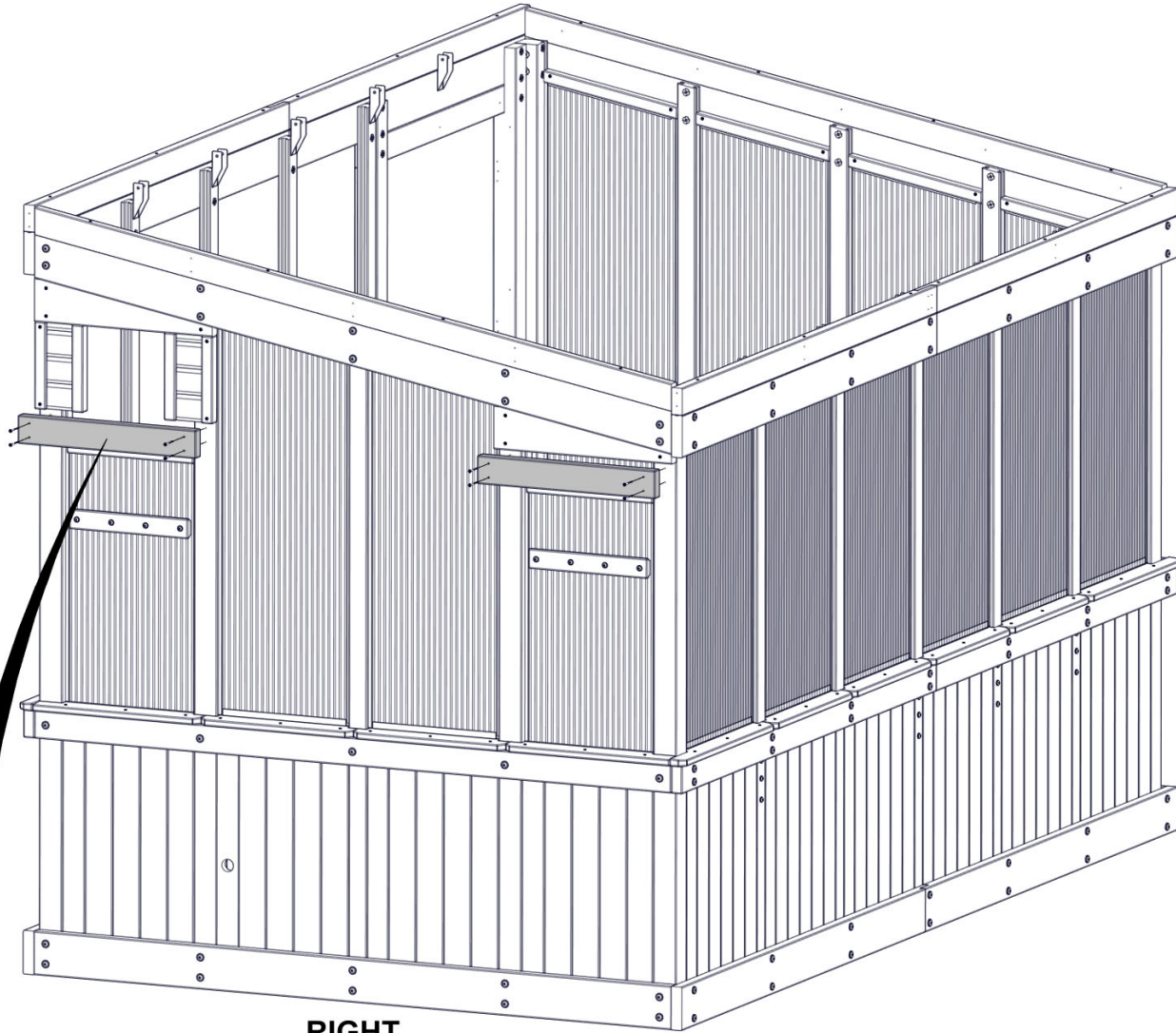

RIGHT

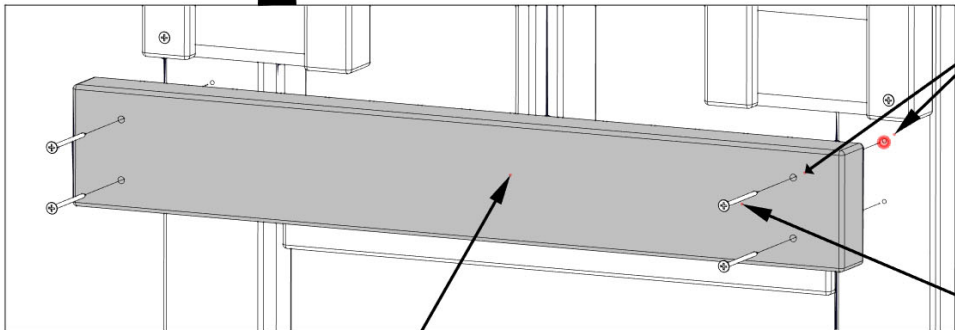

**ALIGN WINDOW TRIM WITH
PILOT HOLES BEFORE
INSERTING SCREWS**

**483 (x8)
SCREW - 2 1/4"**

**E05 (x2)
WINDOW TRIM**

STEP 63 - RIGHT WINDOWS

Qty	PART NUMBER	DESCRIPTION
6	H100391	SCREW PFH 8 X 2 BLK



F07 WINDOW LATCH BOARD - W4L18741
(x2) 1 7/16"x1 9/16"x17 1/4" (36x40x438)

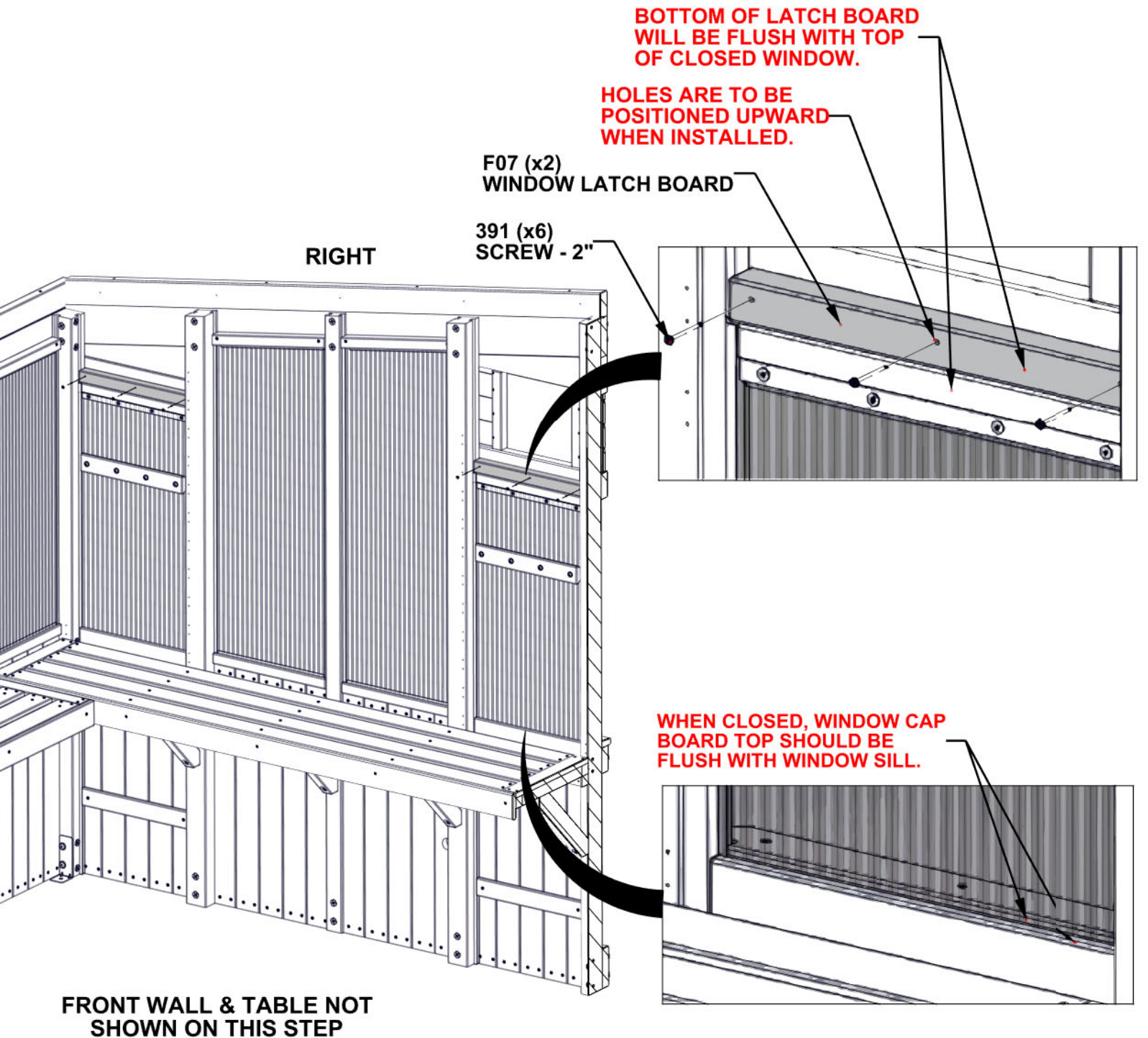

STEP 64 - RIGHT WINDOWS

Qty	PART NUMBER	DESCRIPTION
8	H100627	SCREW PFH 6 x 3/4 BLK

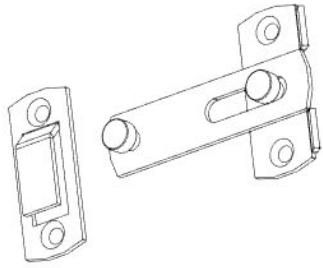

A4M02607 WINDOW LATCH LOCK
(x2)

- NOTES:**
- CENTER WINDOW LATCH ON WINDOW CAP BOARD.
 - WITH THE WINDOW LOCK ASSEMBLED AS SHOWN IN DETAIL, MARK HOLES AND DRILL PILOT HOLES USING A 3/32" DRILL BIT.
 - ATTACH AS SHOWN.

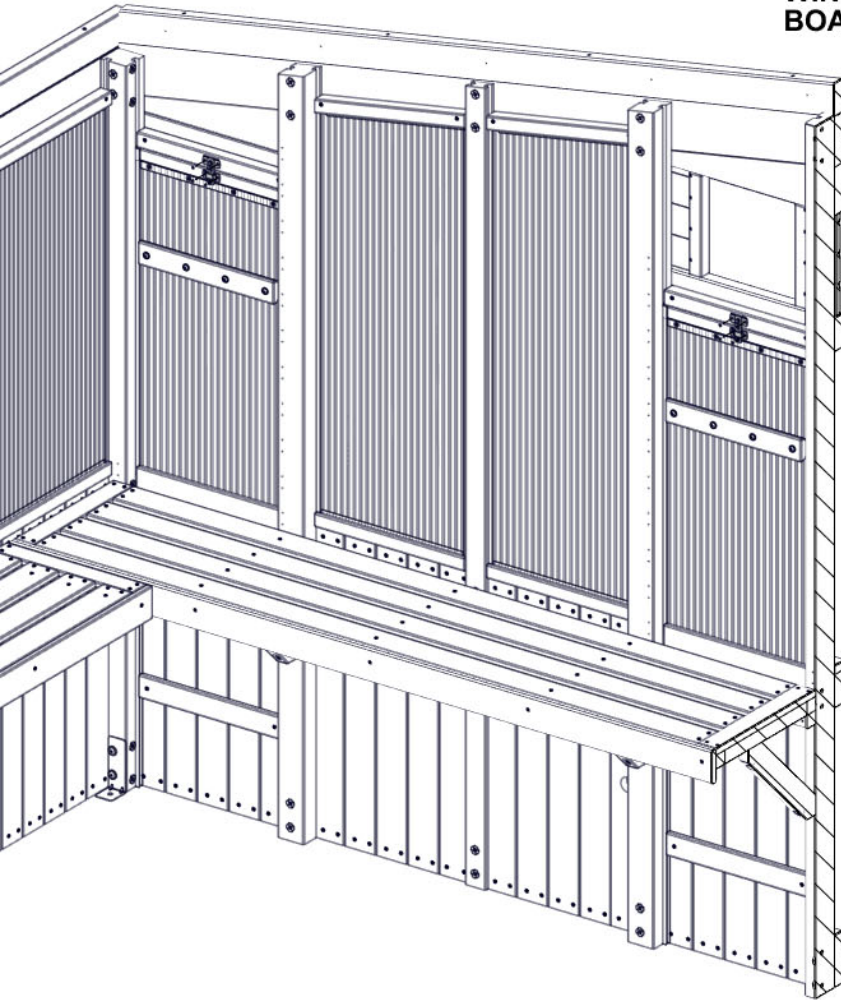

WINDOW CAP BOARD

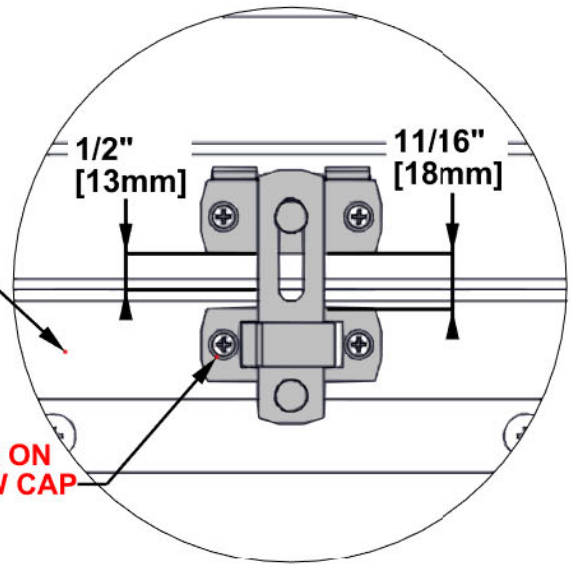

CENTER ON WINDOW CAP BOARD

2607 (x2)
WINDOW LATCH LOCK

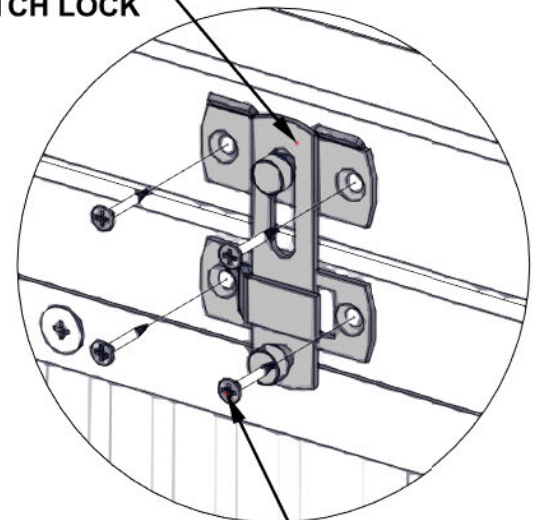

627 (x8)
SCREW - 3/4"

FRONT WALL & TABLE NOT SHOWN ON THIS STEP

STEP 65 - EXHAUST FAN

Qty	PART NUMBER	DESCRIPTION
8	H101205	SCREW PWH 8 X 15 X 3/4 BLK

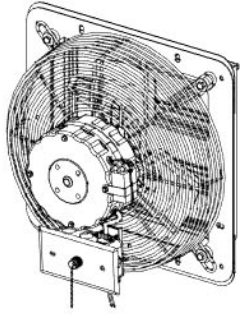

A4M02383 EXHAUST FAN
(x1)

NOTES:
CENTER EXHAUST FAN IN THE
OPENING AND ATTACH AS SHOWN.

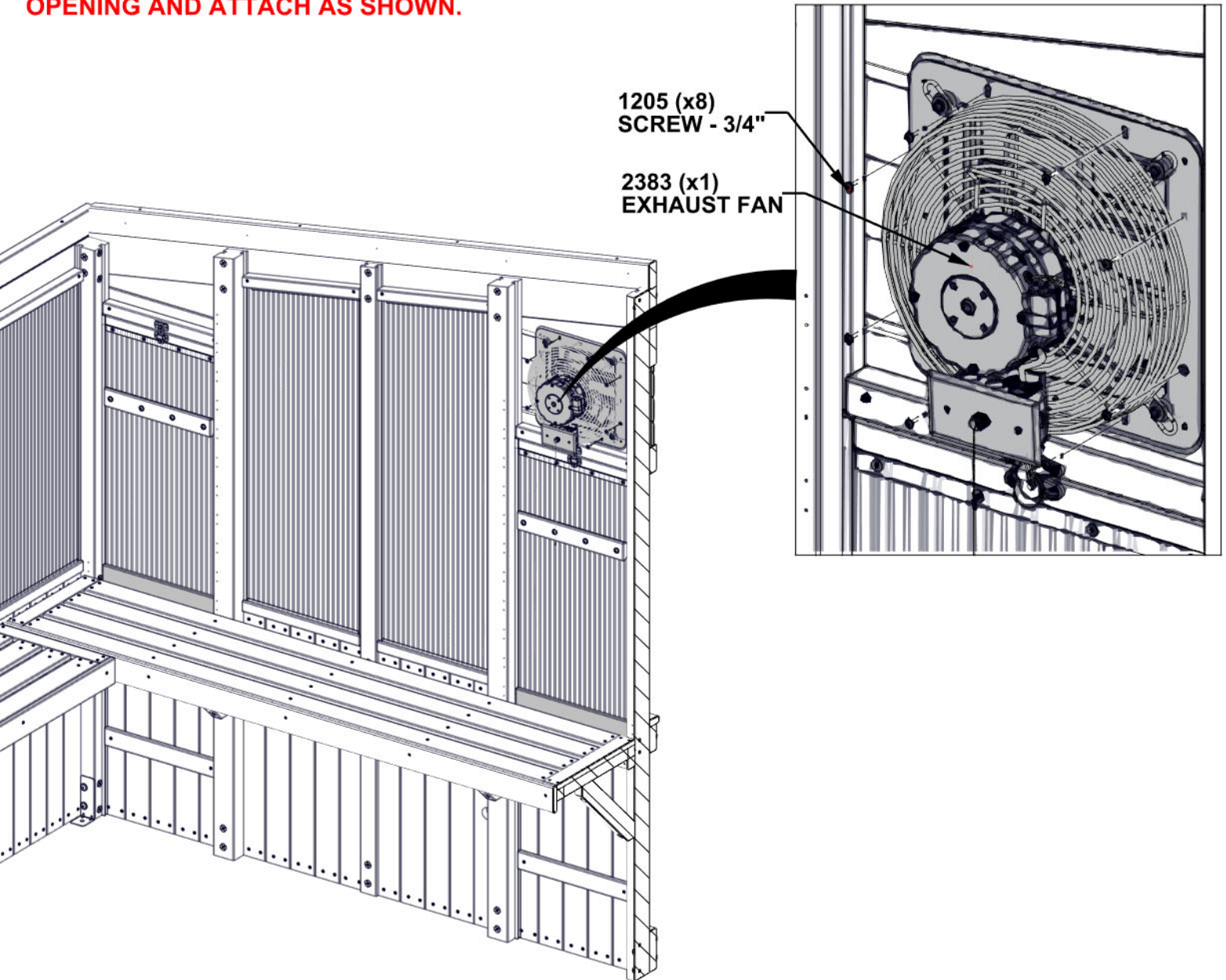

**FRONT WALL & TABLE NOT
SHOWN ON THIS STEP**

STEP 66 - HANGER BOARDS

Qty	PART NUMBER	DESCRIPTION
48	H100391	SCREW PFH 8 X 2 BLK

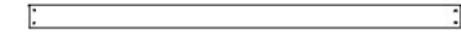

N01 HANGER BOARD - W4L18737
(x10) 5/8"x2 3/8"x42 15/16" (16x60x1090)



N07 HANGER BOARD - W4L18819
(x1) 5/8"x2 3/8"x80 7/16" (16x60x2043)

NOTES:

- ALIGN HANGER BOARDS WITH PILOT HOLES ON UPRIGHTS BEFORE INSERTING SCREWS.
- START WITH N07 AND WORK UP.

391 (x48)
SCREW - 2"

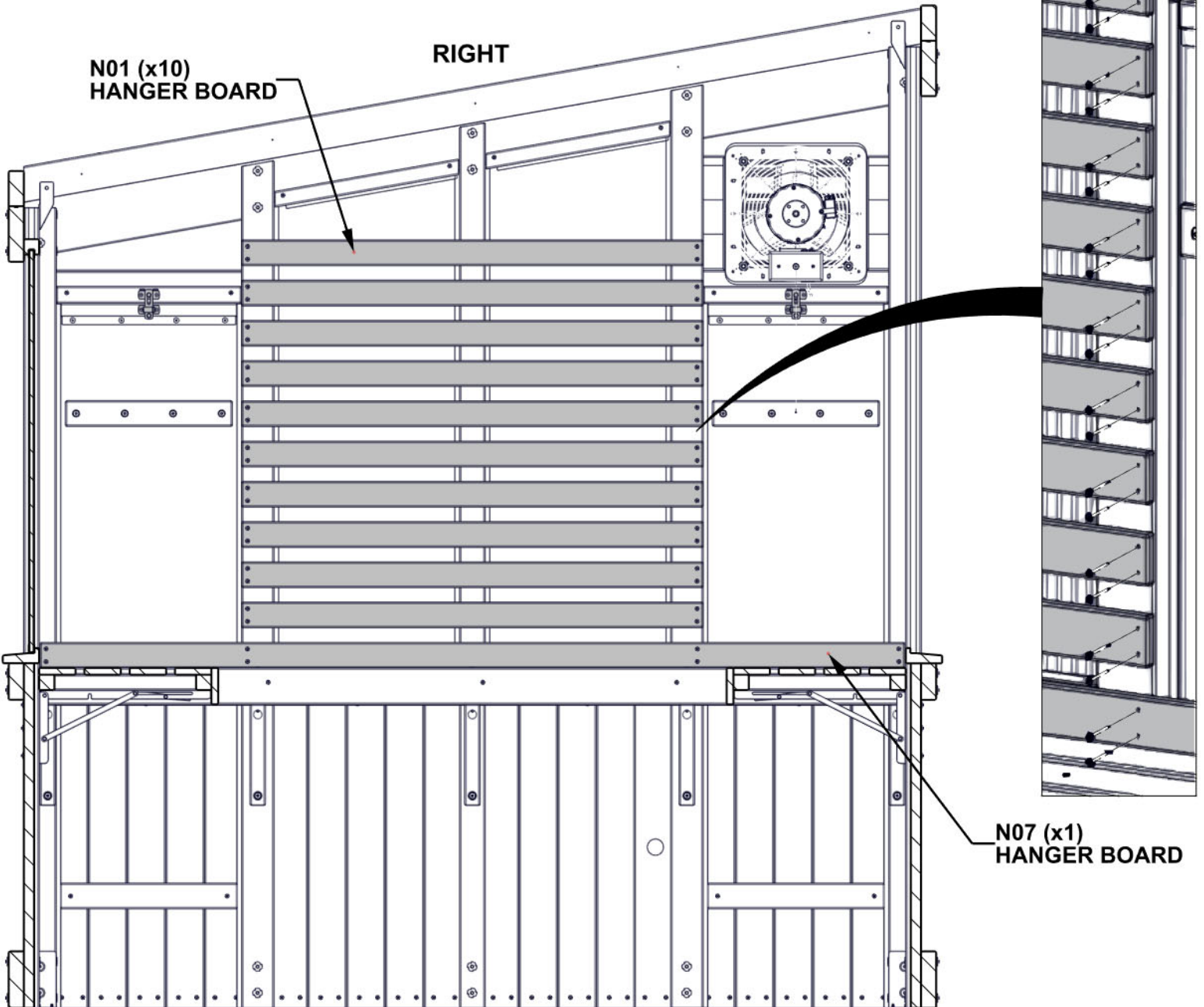

STEP 67 - FRONT WINDOWS



A6P00681 POLY CHANNEL WITH TAPE
(x8)

NOTES:
INSTALL (8) CHANNELS (2 PER WINDOW) BY REMOVING TAPE LINER & PUSH CHANNEL FIRMLY INTO WOOD GROOVES ON UPRIGHTS.

INSERT POLY CHANNEL INTO GROOVES STARTING AT THE WINDOW LEDGE & WORK UPWARDS.

POLY CHANNEL WILL COME WITH DOUBLE SIDED TAPE INSTALLED. REMOVE LINER BEFORE INSTALLATION.

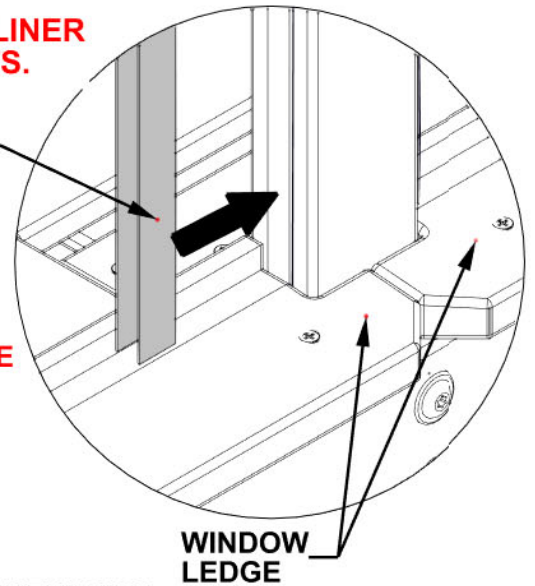

WINDOW LEDGE

681 (x8)
POLY CHANNEL WITH TAPE

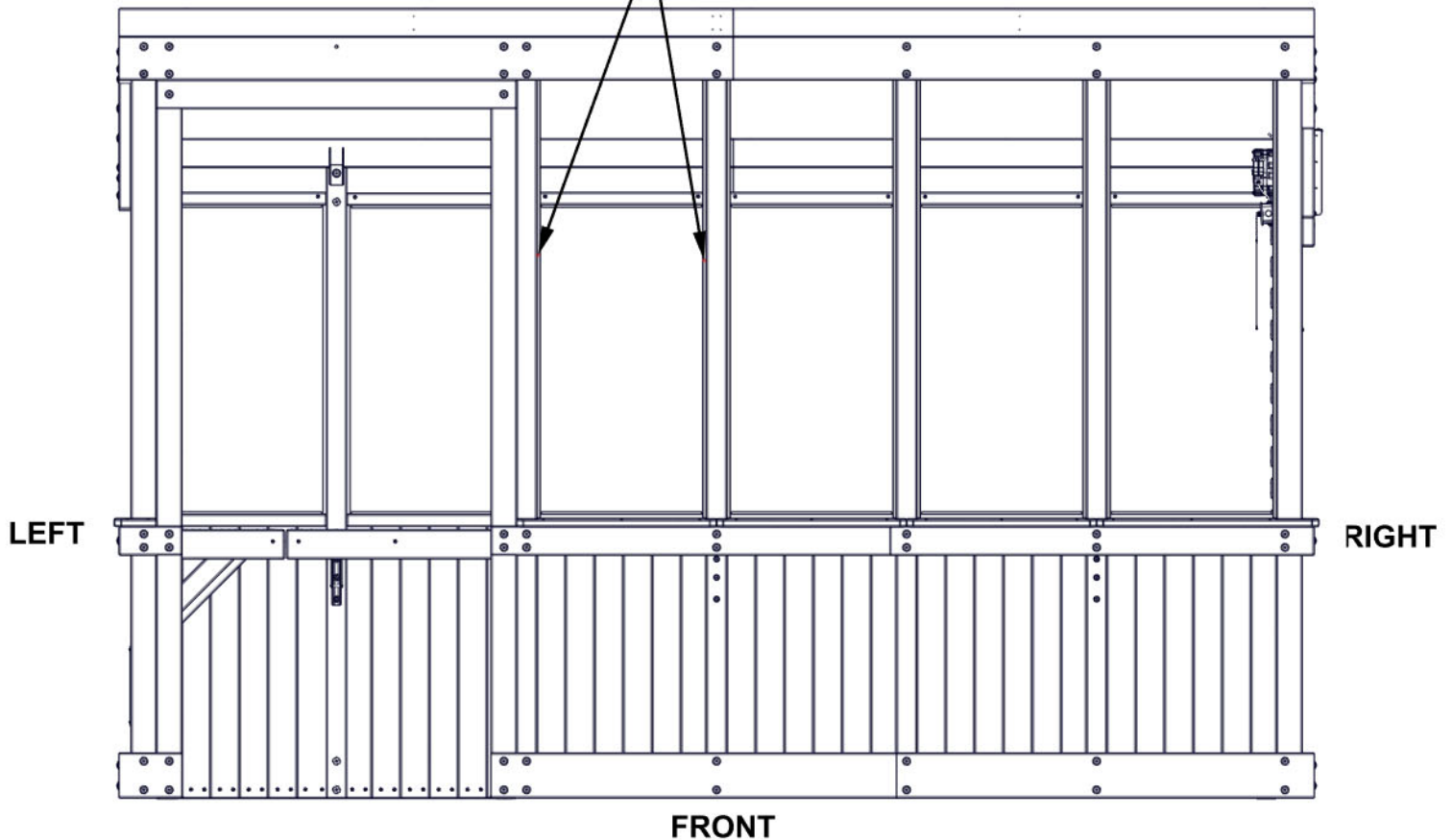

STEP 68 - FRONT WINDOWS

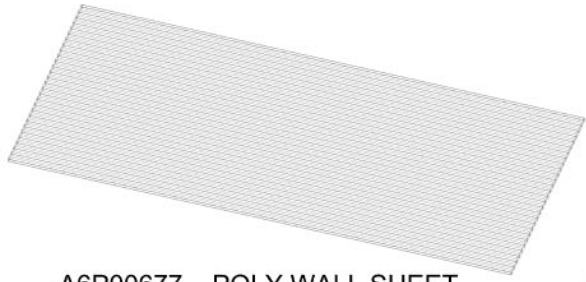

A6P00677 POLY WALL SHEET
(x4)

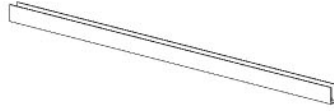

A6P00667 POLY CHANNEL
(x8)



A6P00690 DUST SEAL TAPE

NOTES:

1. INSTALL DUST TAPE ON TOP & BOTTOM ON EACH POLY SHEETING.
 - CUT (2) STRIPS OF DUST SEAL TAPE THE SAME WIDTH AS THE POLY SHEETING.
 - WRAP DUST SEAL TAPE ALONG EDGE OF POLY SHEETING WIDTH.
2. AFTER TAPE IS SECURE, PUSH CHANNEL ON OVER THE TOP OF THE TAPE.
 - CENTER CHANNEL ON SHEET WITH APPROXIMATELY 1" (25mm) CLEARANCE ON EACH SIDE OF POLY SHEET AS SHOWN.
3. REPEAT FOR ALL (4) WINDOWS.

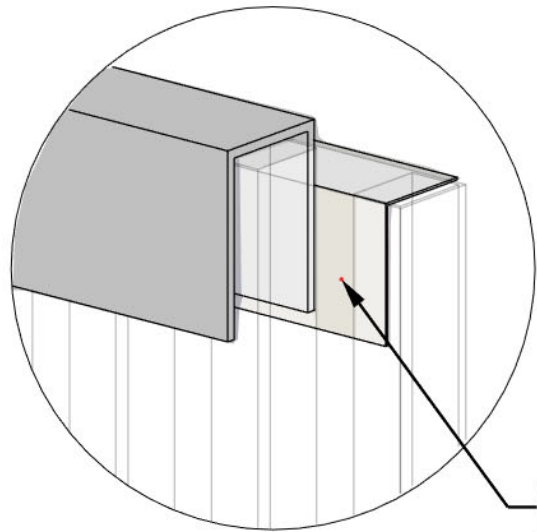

667 (x1)
POLY CHANNEL

690 (x2)
DUST SEAL TAPE

677 (x1)
POLY WALL SHEET

667 (x1)
POLY CHANNEL

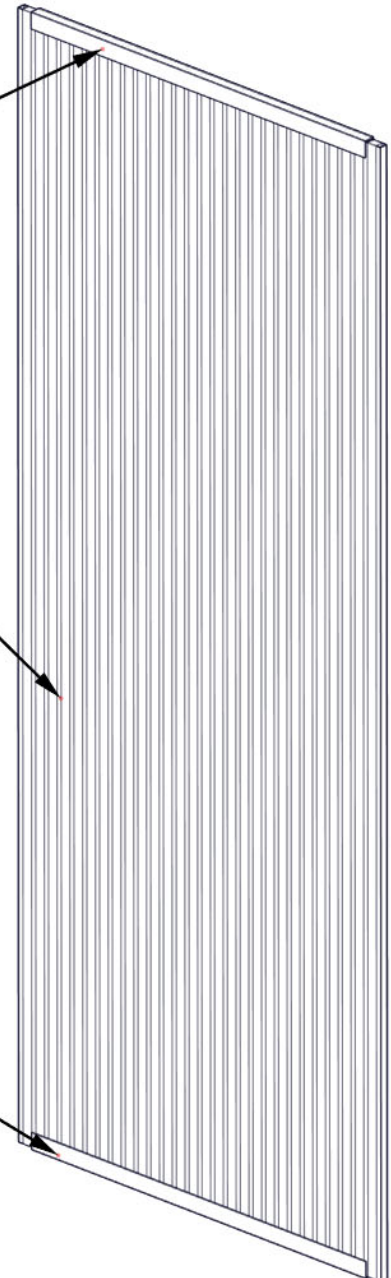

STEP 69 - FRONT WINDOWS

NOTES:

- **INSERT WINDOW ASSEMBLY INTO PREVIOUSLY INSTALLED CHANNEL ON BOTH SIDES OF WINDOW.**
- **GENTLY SLIDE WINDOW DOWN UNTIL SEATED ON WINDOW LEDGE.**
- **IMPORTANT! ENSURE UV SIDE OF POLY SHEETING IS FACING OUTSIDE.**
- **SAFE TO REMOVE PROTECTIVE FILM FROM INSTALLED WINDOW.**

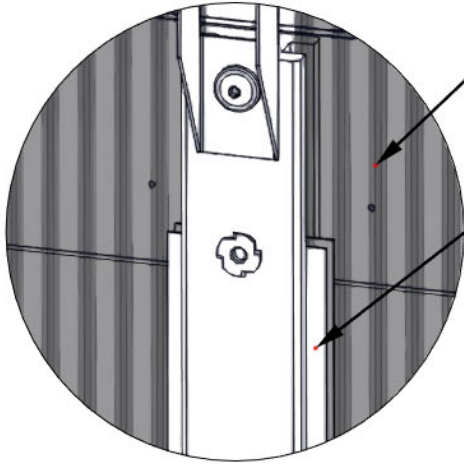

WINDOW ASSEMBLIES (4)
FROM STEP 68

POLY CHANNEL
FROM STEP 67

INSIDE VIEW

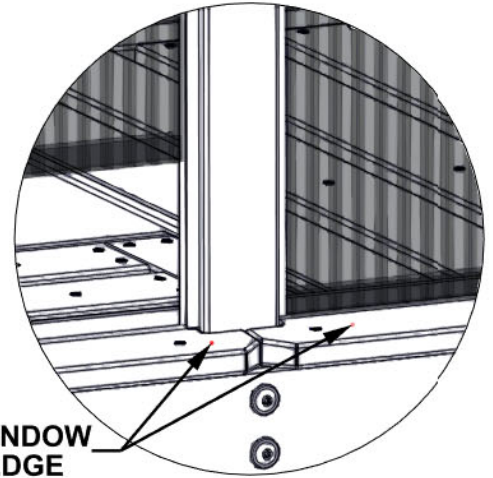

WINDOW
LEDGE

OUTSIDE VIEW

FRONT

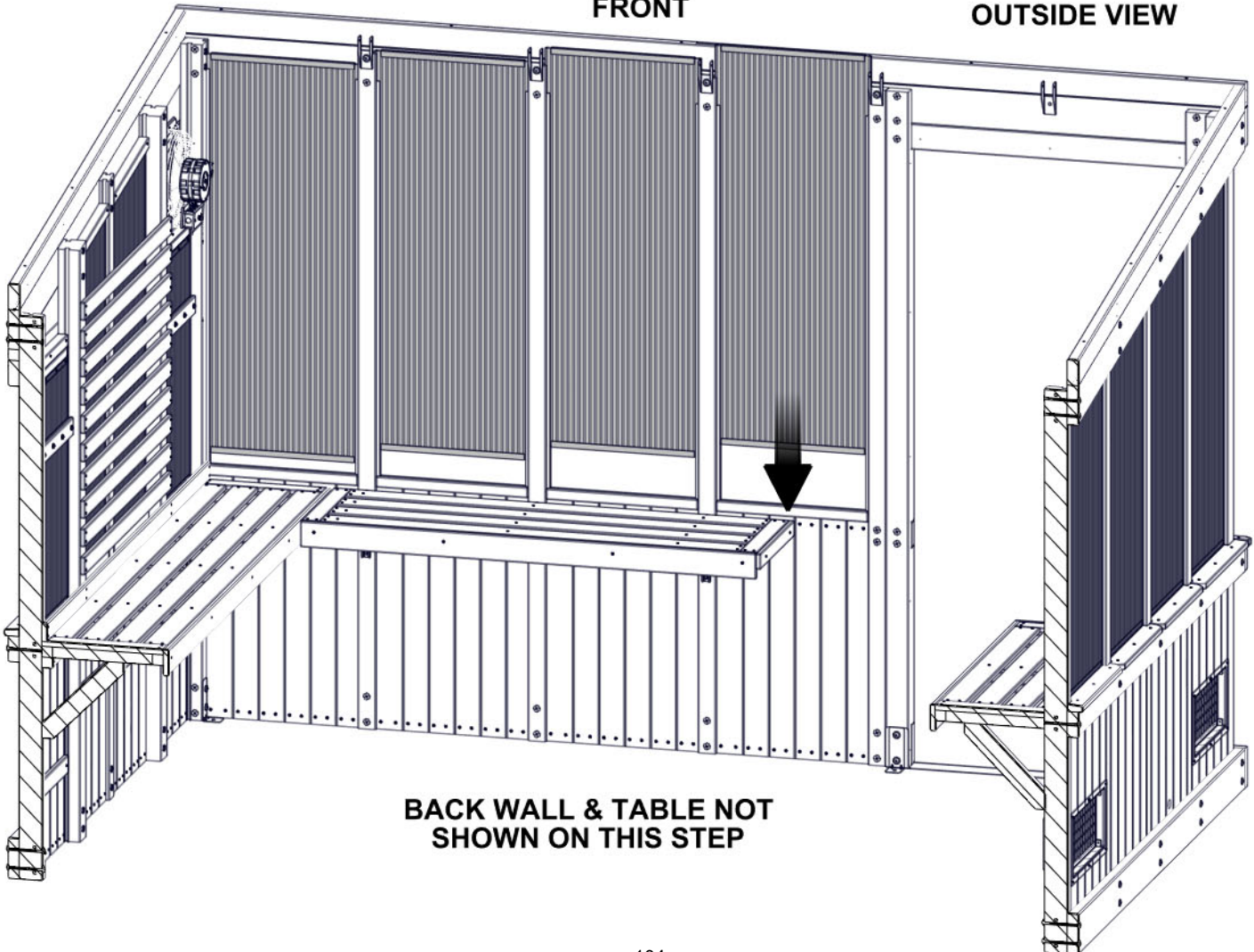

BACK WALL & TABLE NOT
SHOWN ON THIS STEP

STEP 70 - FRONT WINDOWS

Qty	PART NUMBER	DESCRIPTION
8	H100483	SCREW PFH 8 X 2 1/4 BLK



P03 WINDOW CAP BOARD - W4L18732
(x4) 1 7/16"x1 7/16"x19 7/8" (36x36x505)

NOTES:
ATTACH WINDOW CAP BOARD TO THE TOP OF THE WINDOW AS SHOWN.

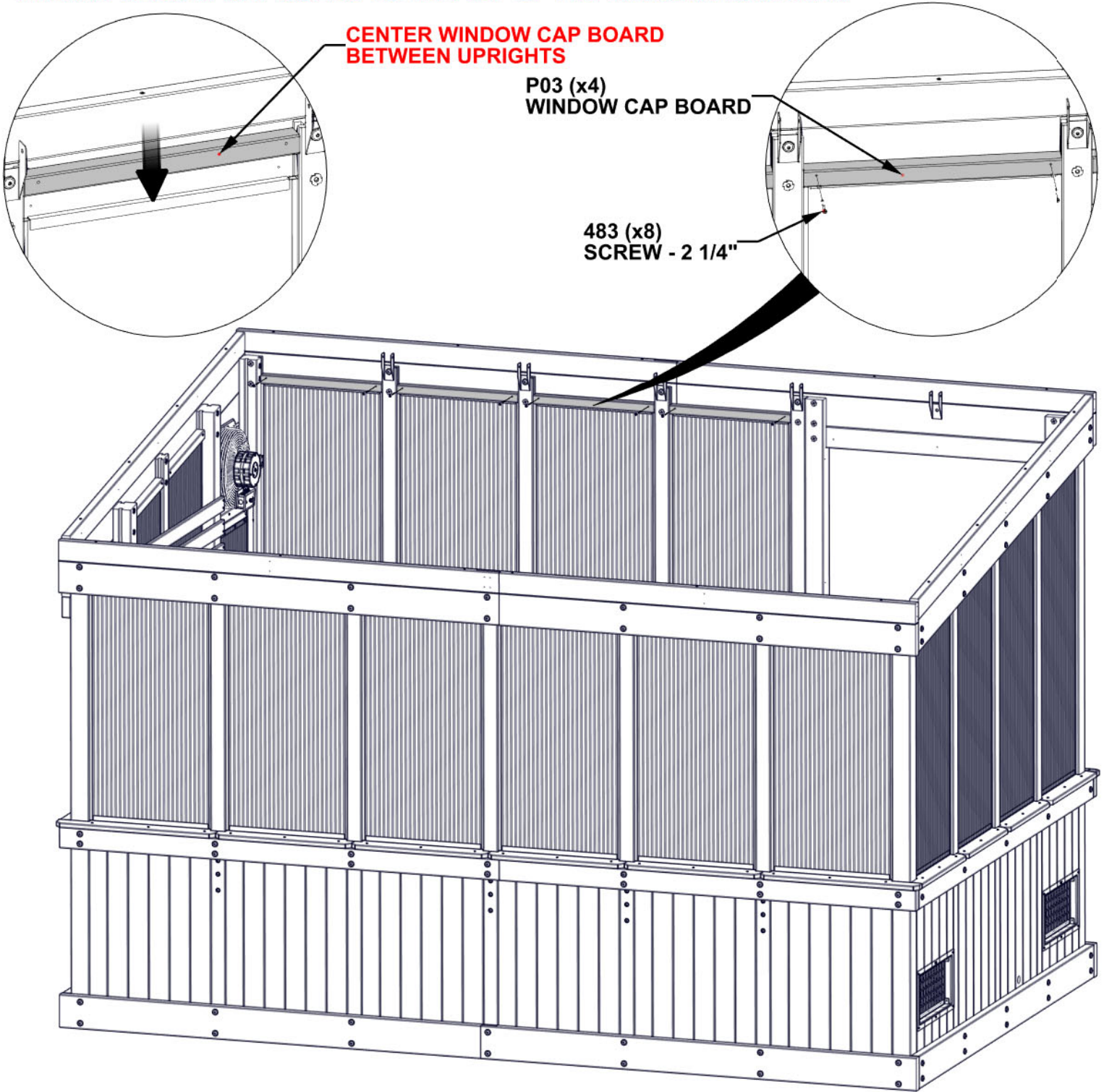

STEP 71 - ROOF SUPPORT

Qty	PART NUMBER	DESCRIPTION
30	H100391	SCREW PFH 8 X 2 BLK

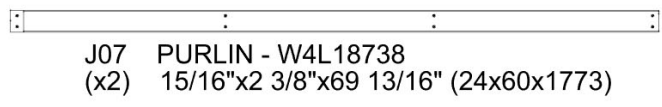
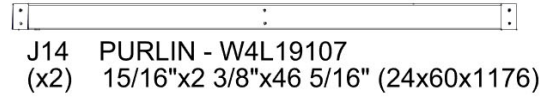
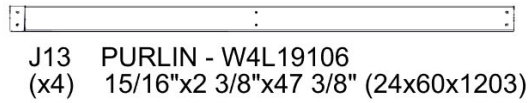
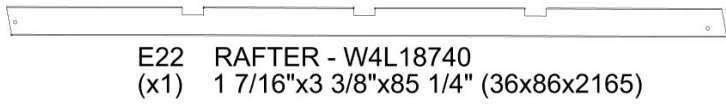

1 1/16" [18mm]

HOLES NEED TO BE CENTERED ON RAFTER BEFORE INSERTING SCREWS

391 (x30)
SCREW - 2"

ATTACH USING PILOT HOLES IN RAFTERS.

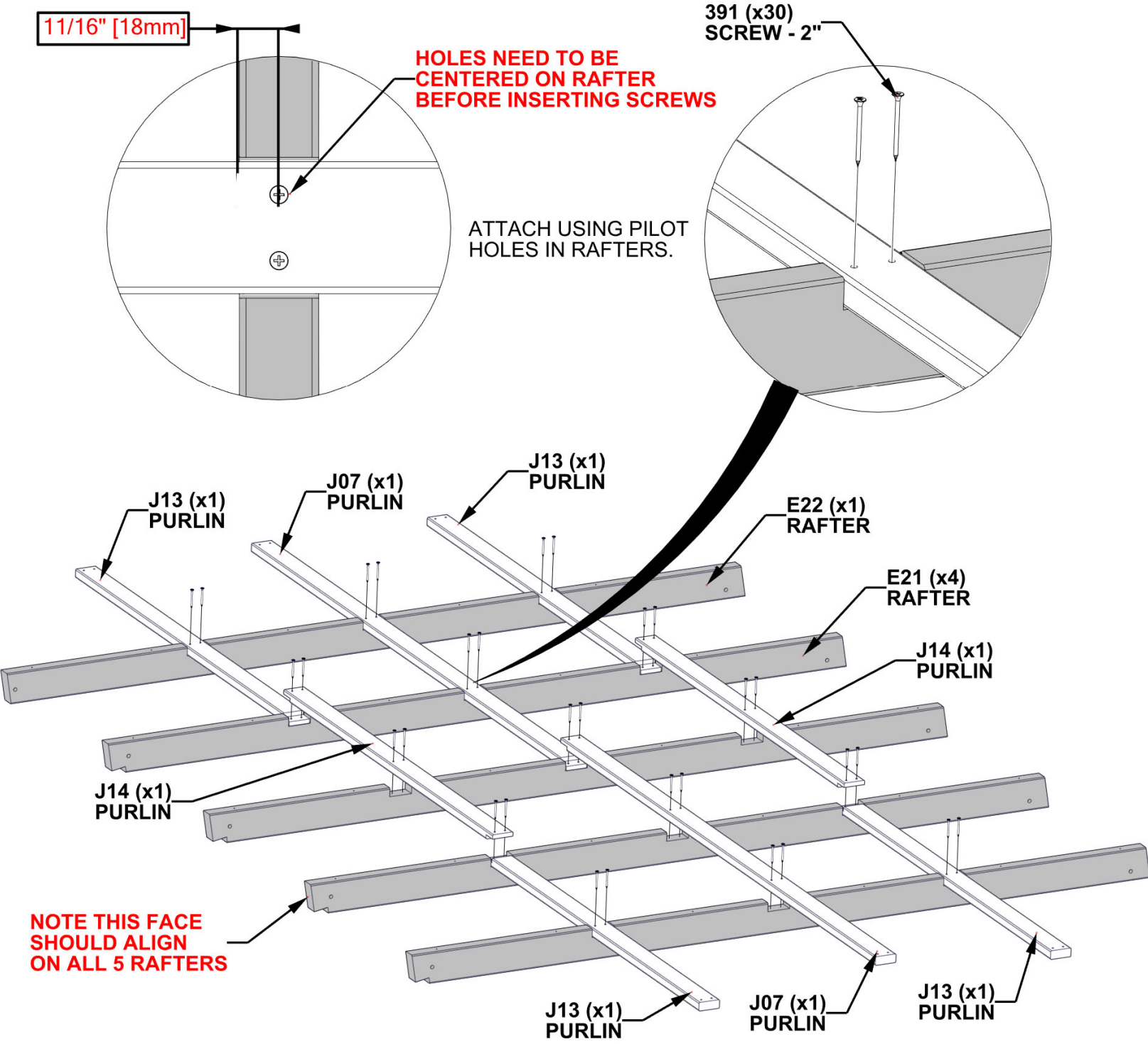

STEP 72 - ROOF SUPPORT

TIP: LOOSEN HARDWARE TO ADJUST FOR SQUARING IF NEEDED.

CRITICAL!

- SQUARE UNIT BEFORE PROCEEDING TO NEXT STEPS.
- THE BELOW DIMENSIONS ARE CRITICAL TO THE FINAL ROOF ASSEMBLY.
- MEASUREMENTS SHOULD BE HELD WITHIN $\pm 1/4"$.
- MEASUREMENTS OUTSIDE OF TOLERANCE WILL LEAD TO THE INABILITY TO ASSEMBLE THE ROOF
- ONCE CONFIRMED SQUARE, TIGHTEN ALL HARDWARE.

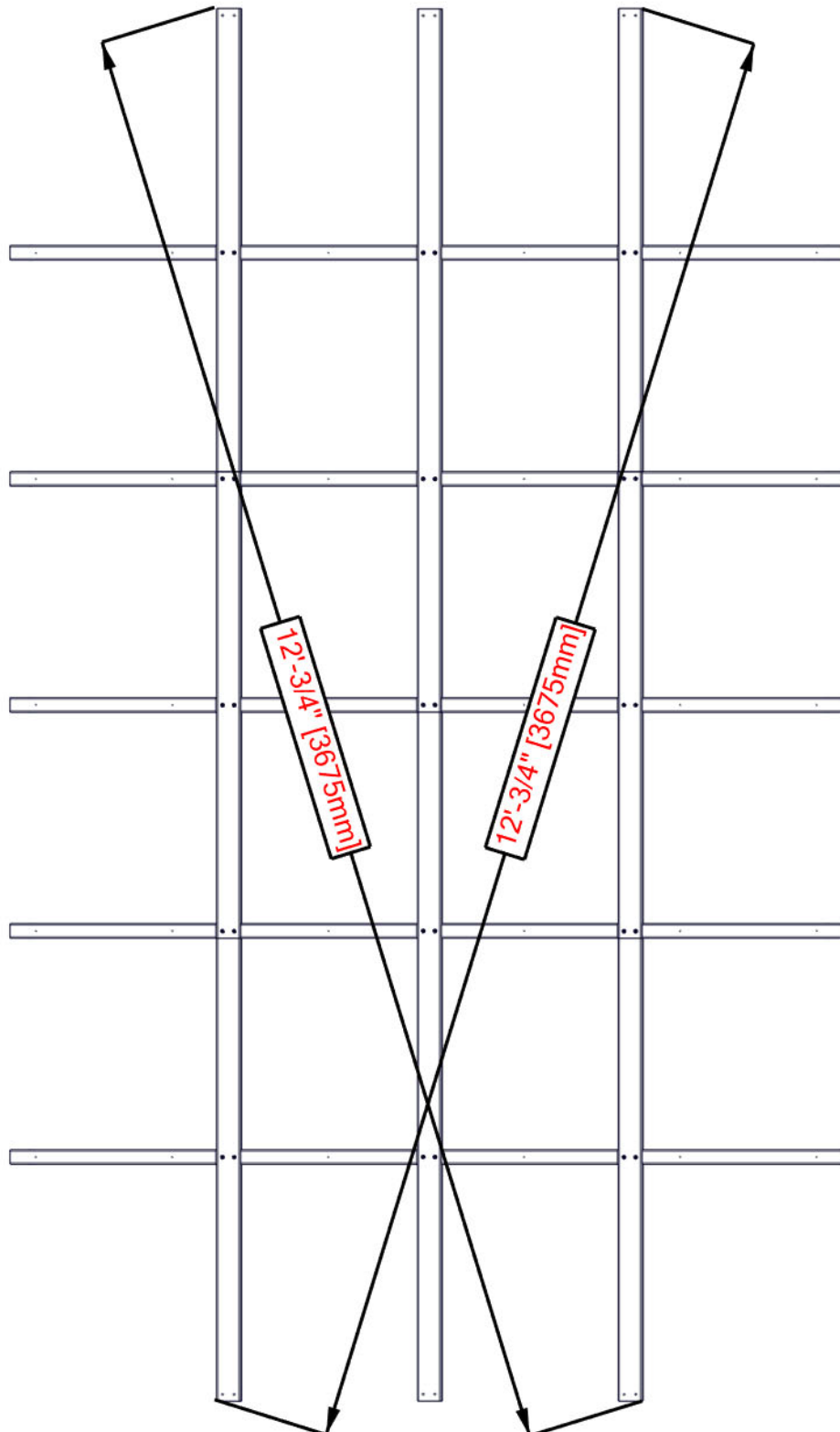

STEP 73 - ROOF SUPPORT

Qty	PART NUMBER	DESCRIPTION
30	H101203	SCREW PWH 8 X 15 X 1 1/4 BLK

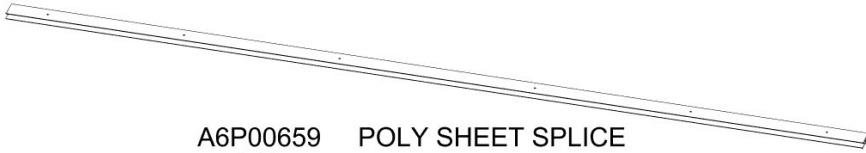

A6P00659 POLY SHEET SPLICE
(x5)

NOTES:

- ALIGN HOLES IN POLY SHEET SPLICES WITH PILOT HOLES ON RAFTERS.
- ATTACH AS SHOWN, DO NOT OVER TIGHTEN.

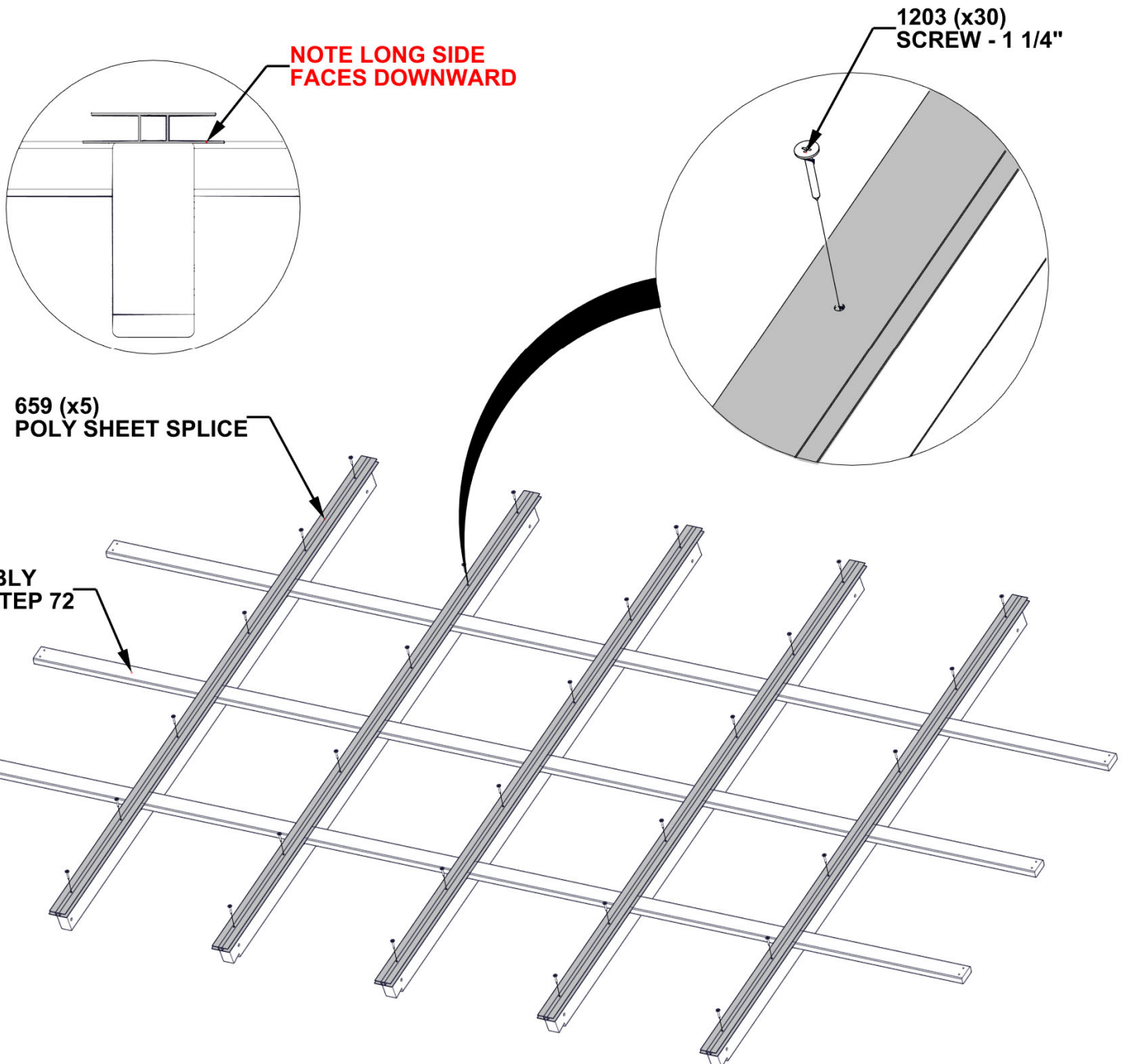

**SET STEP 73 ASSEMBLY
TO THE SIDE**

STEP 74 - ROOF SUPPORT

Qty	PART NUMBER	DESCRIPTION
10	H100483	SCREW PFH 8 X 2 1/4 BLK

P07 CLEAT - W4L18739
(x2) 1 7/16"x1 7/16"x76 3/4" (36x36x1950)

NOTES:

- ALIGN CLEAT HOLES WITH PILOT HOLES ON HEADERS BEFORE INSERTING SCREWS.
- REPEAT CLEAT INSTALLATION ON LEFT SIDE.

NOTE PILOT HOLES SHOULD BE UPWARD

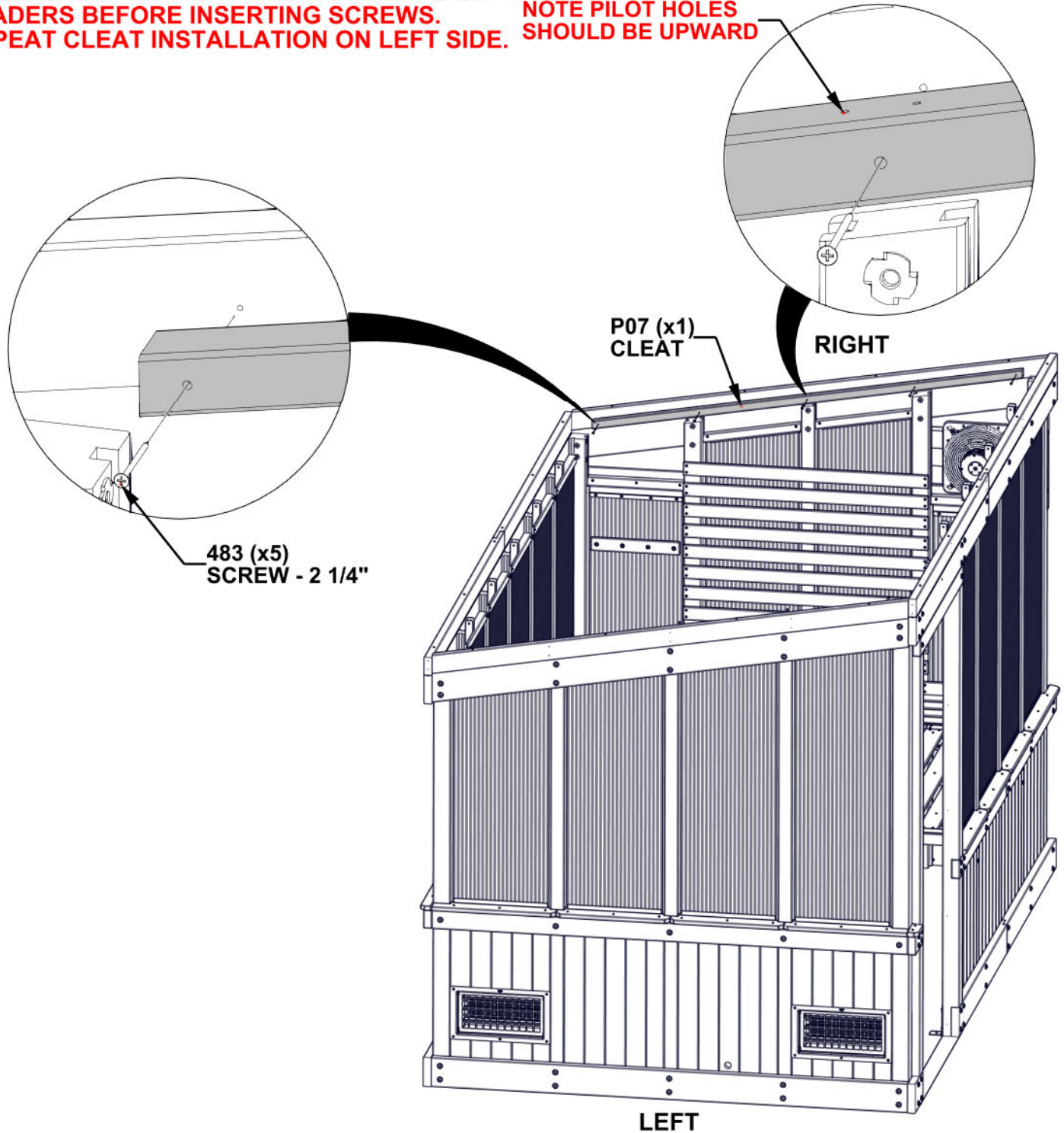

STEP 75 - ROOF SUPPORT

Qty	PART NUMBER	DESCRIPTION
10	H100488	BOLT WH 1/4 X 2 BLK
10	H100630	WASHER FLAT 8x19 BLK
10	H100653	NUT LOCK 1/4 BLK

NOTES:
CAUTION! WILL NEED AT LEAST TWO PEOPLE TO LIFT ROOF SUPPORT ASSEMBLY AND PLACE IT INTO THE RAFTER BRACKETS.

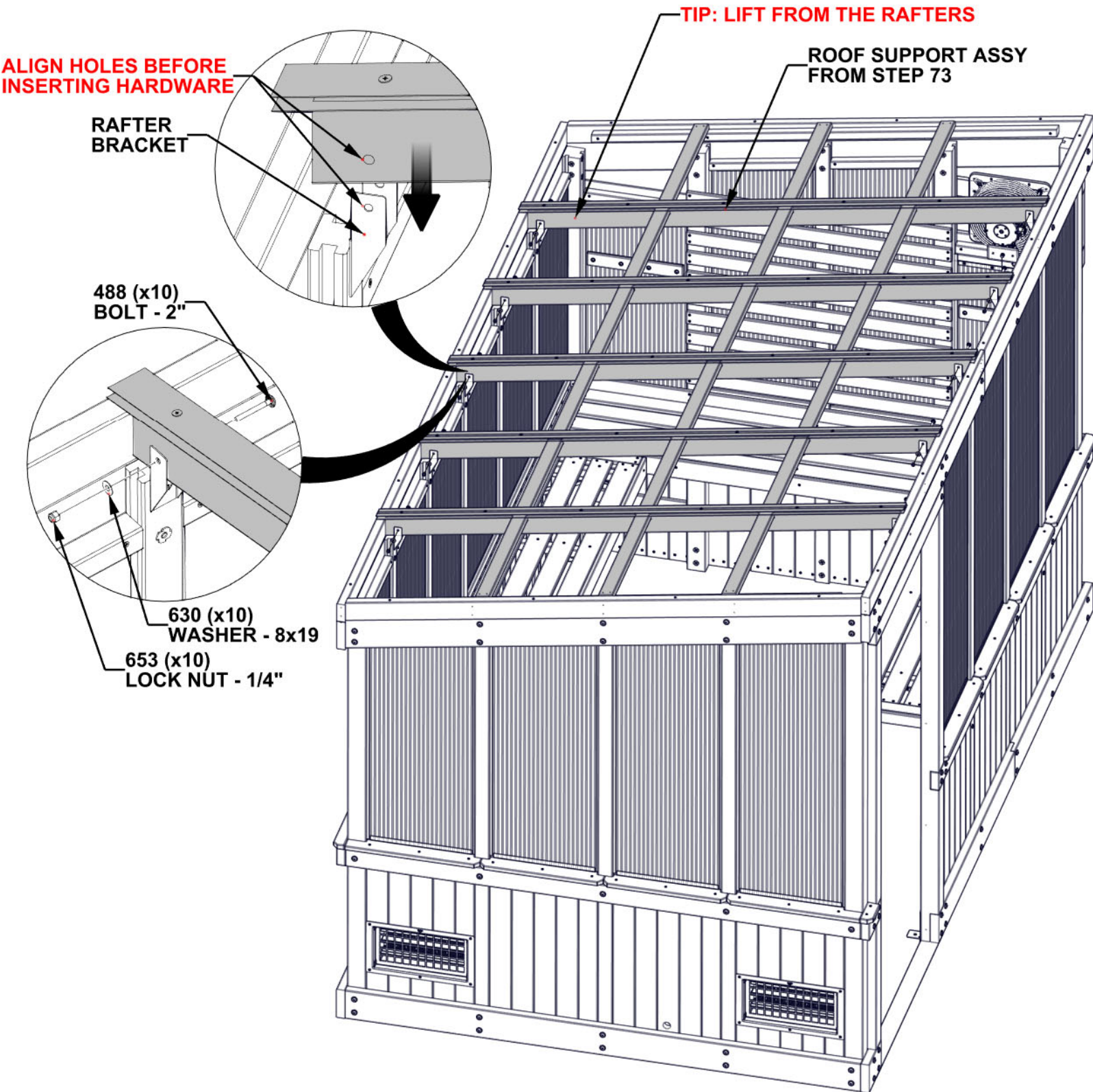

STEP 76 - ROOF SUPPORT

Qty	PART NUMBER	DESCRIPTION
12	H100391	SCREW PFH 8 X 2 BLK

NOTE:
ALIGN HOLES IN PURLINS WITH PILOT HOLES
ON CLEATS & ATTACH AS SHOWN.

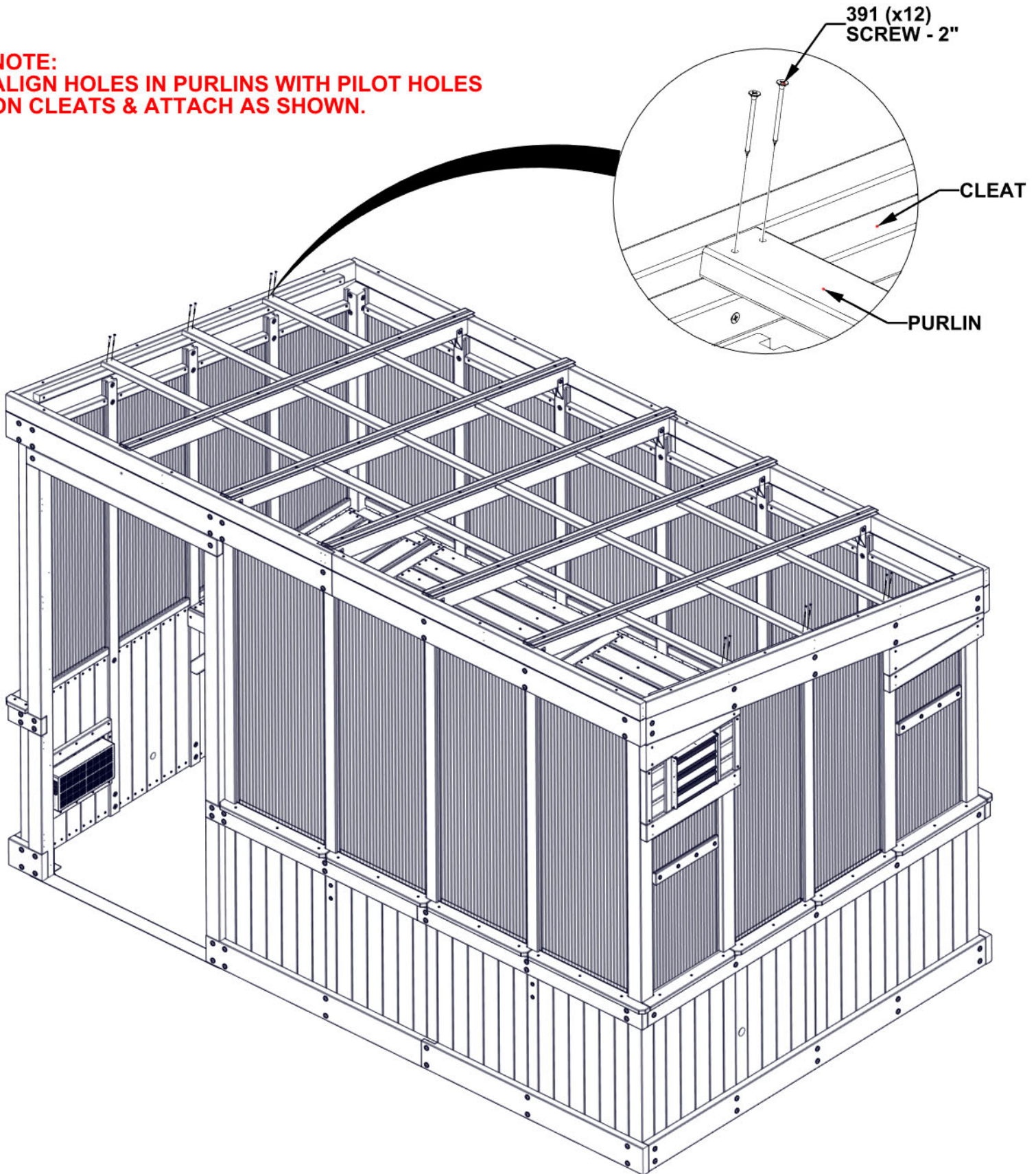

STEP 77 - FASCIA

Qty	PART NUMBER	DESCRIPTION
10	H100391	SCREW PFH 8 X 2 BLK

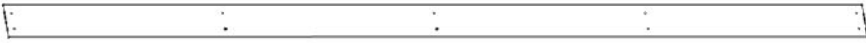

H03 FASCIA - W4L18673
(x1) 15/16"x3 3/8"x88 3/16" (24x86x2240)

NOTES:
ALIGN HOLES IN FASCIA WITH PILOT HOLES
ON HEADER & ATTACH AS SHOWN.

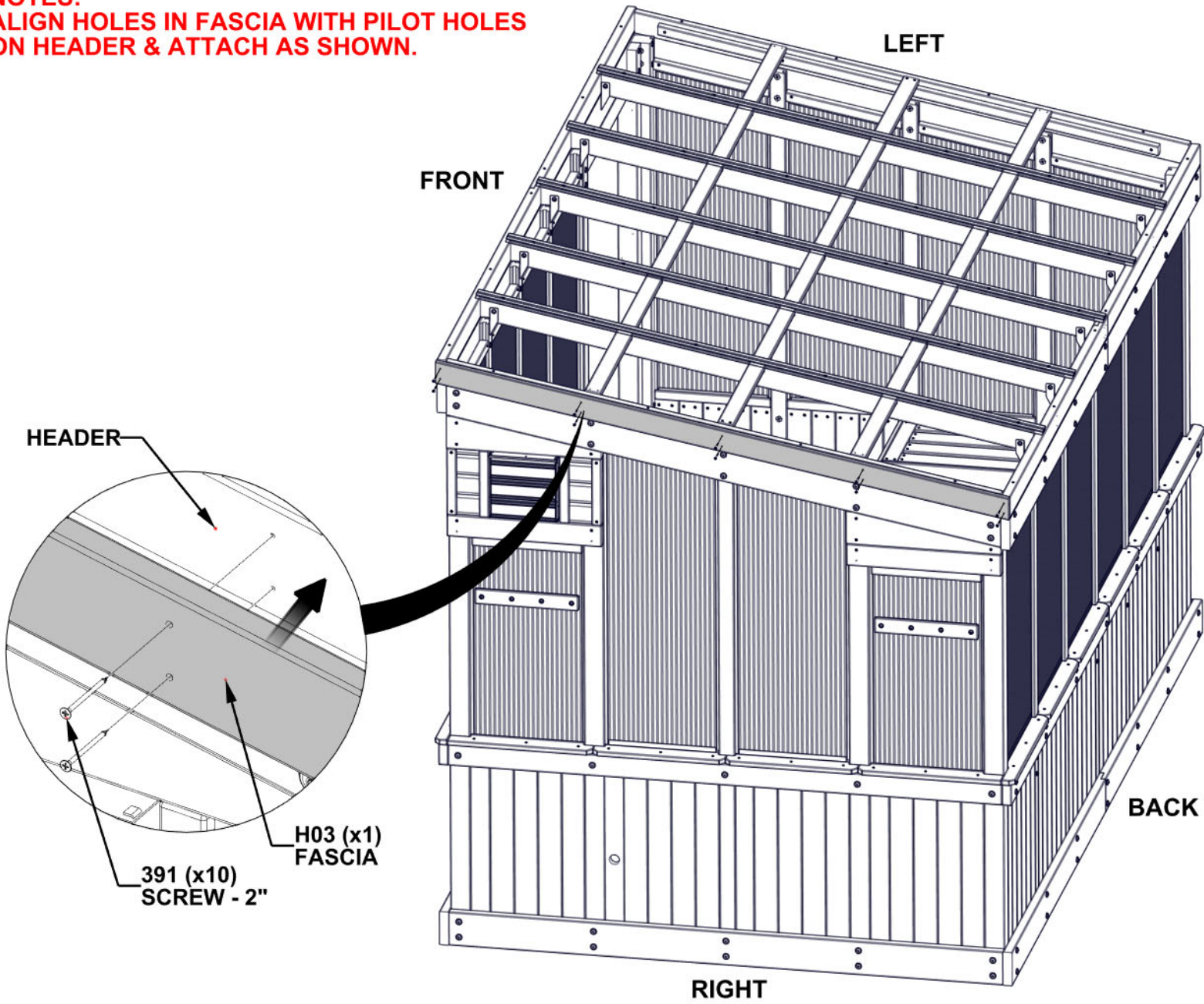

STEP 78 - FASCIA

Qty	PART NUMBER	DESCRIPTION
10	H100391	SCREW PFH 8 X 2 BLK

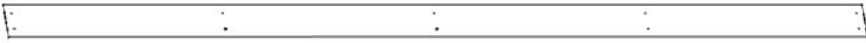

H03 FASCIA - W4L18673
(x1) 15/16"x3 3/8"x88 3/16" (24x86x2240)

NOTES:
ALIGN HOLES IN FASCIA WITH PILOT HOLES ON HEADER & ATTACH AS SHOWN.

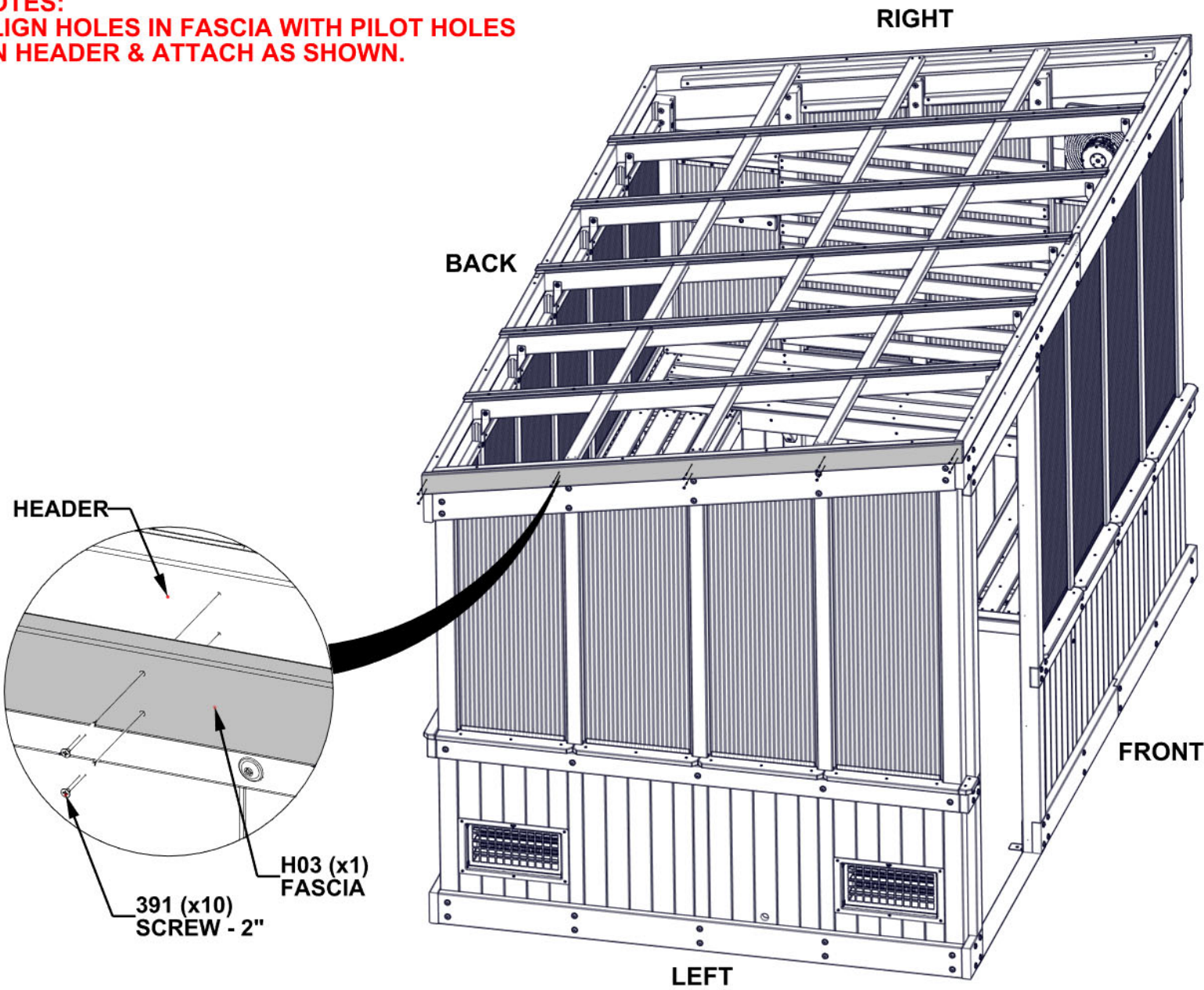

STEP 79 - FASCIA

Qty	PART NUMBER	DESCRIPTION
12	H100391	SCREW PFH 8 X 2 BLK



H01 FASCIA - W4L18671
(x2) 15/16"X3 3/8"X71 9/16" (24x86x1817)

NOTES:
ALIGN HOLES IN FASCIA WITH PILOT HOLES
ON HEADER & ATTACH AS SHOWN.

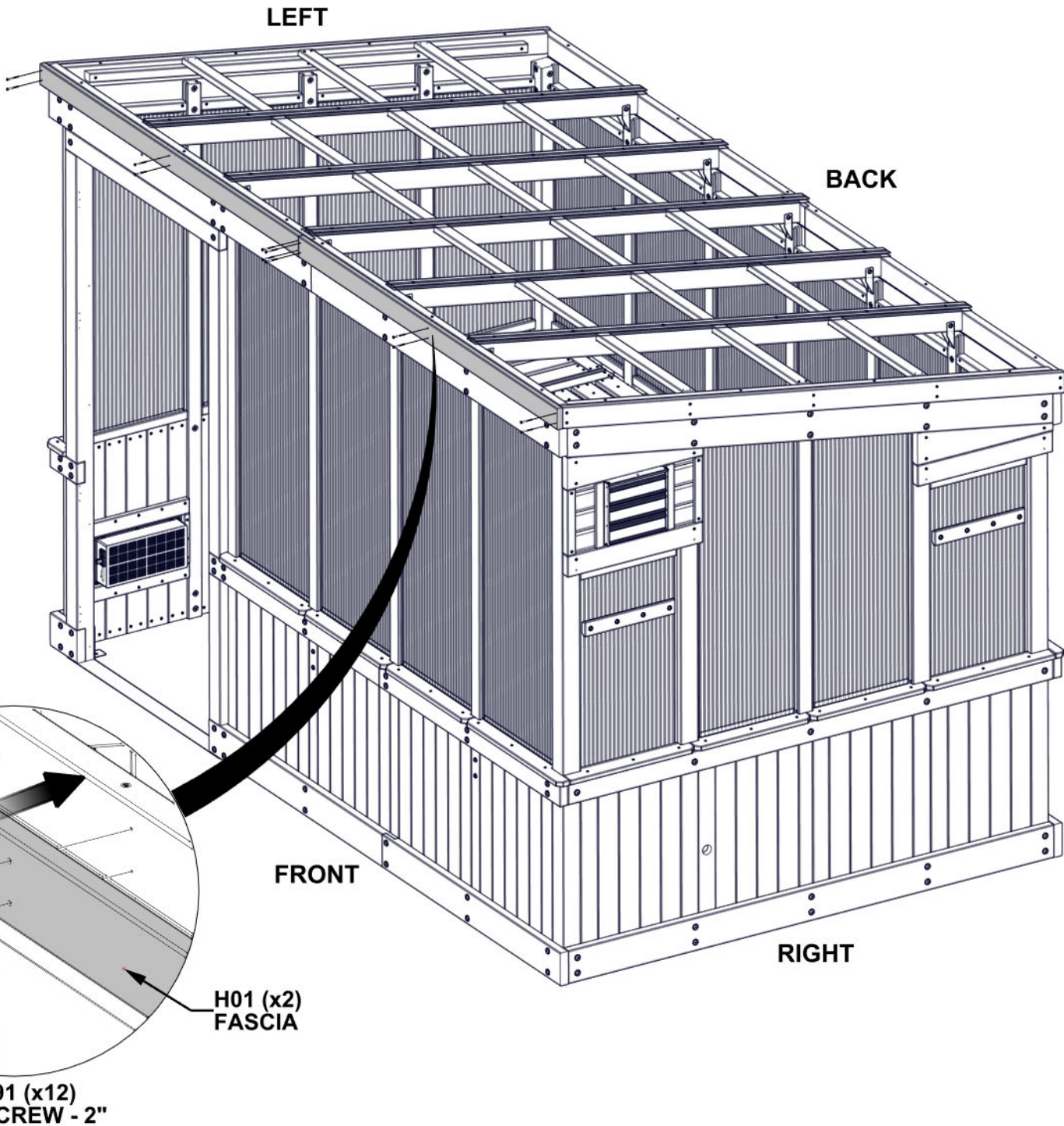

STEP 80 - ROOF ASSEMBLY

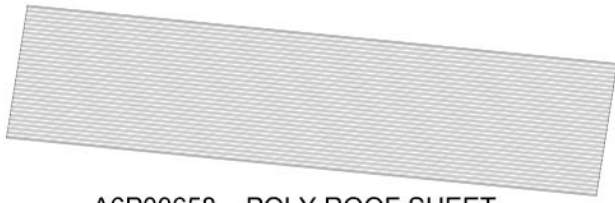

A6P00658 POLY ROOF SHEET
(x4)



A6P00690 DUST SEAL TAPE

NOTES:

1. INSTALL DUST TAPE ON TOP & BOTTOM ON EACH POLY SHEETING.
 - CUT (2) STRIPS OF DUST SEAL TAPE THE SAME WIDTH AS THE POLY SHEETING.
 - WRAP DUST SEAL TAPE ALONG EDGE OF POLY SHEETING WIDTH.
2. REPEAT FOR ALL (4) ROOF SHEETS.

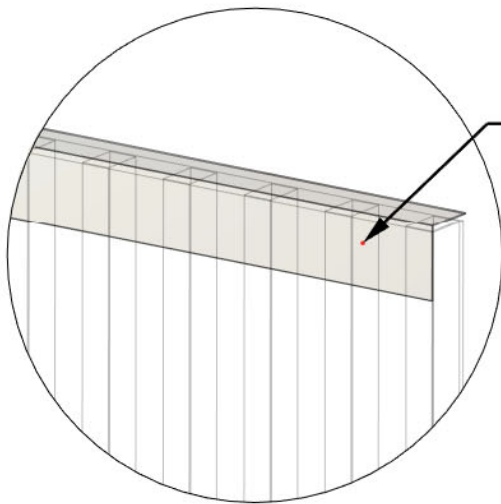

690 (x2)
DUST SEAL TAPE

658 (x1)
POLY ROOF SHEET

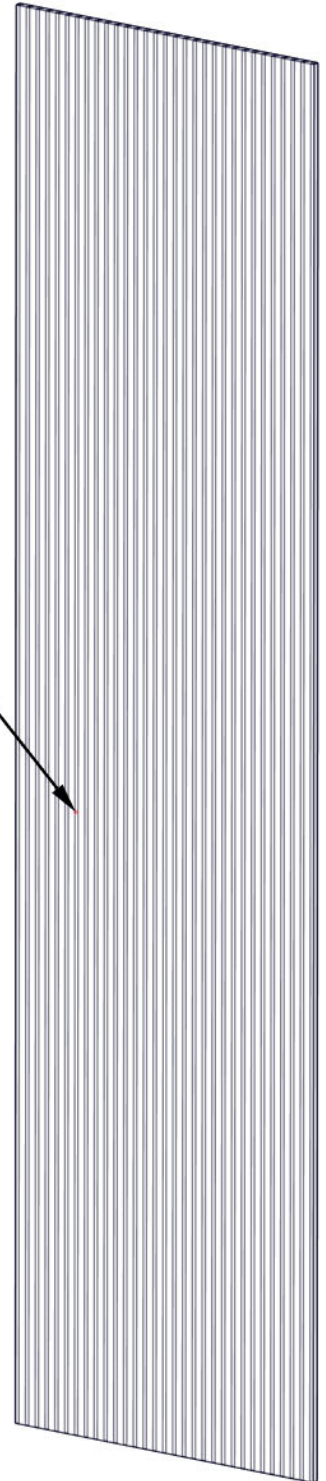

STEP 81 - ROOF ASSEMBLY

NOTES:

- SLIDE ROOF ASSEMBLIES INTO POLY SHEET SPLICES ON ROOF AS SHOWN.
- PUSH UNTIL BOTTOM IS FLUSH WITH FRONT OF FASCIA.
- IMPORTANT! ENSURE UV SIDE OF POLY SHEETING IS FACING OUTSIDE.
- SAFE TO REMOVE PROTECTIVE FILM IMMEDIATELY BEFORE INSTALLATION.

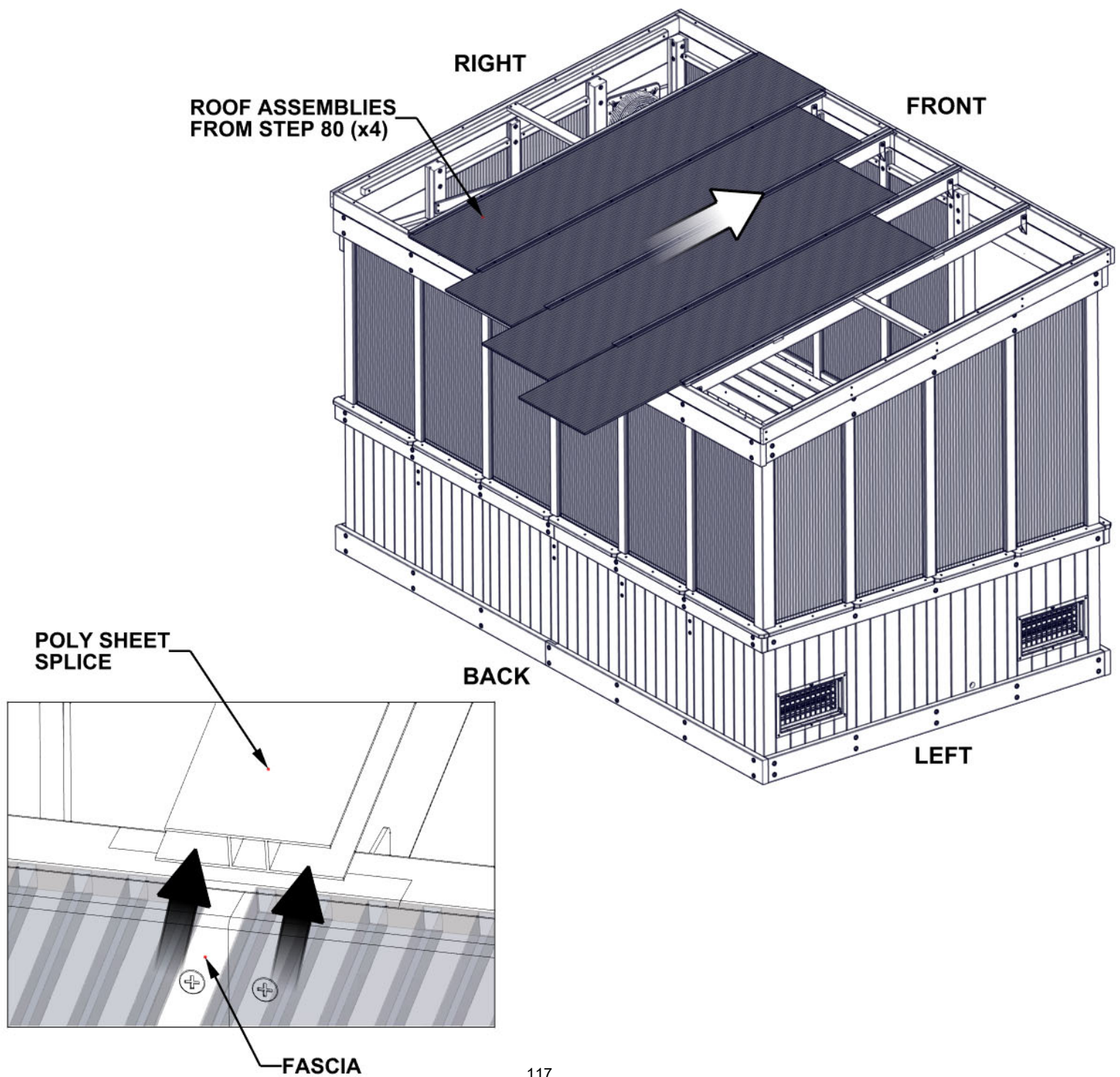

STEP 82 - ROOF ASSEMBLY

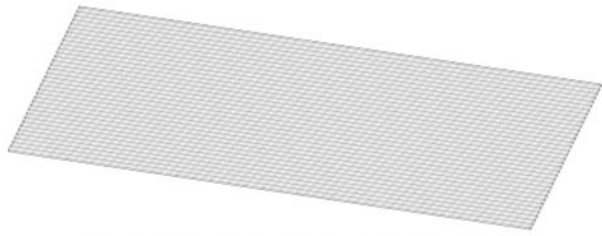

A6P00660 POLY ROOF SHEET
(x2)



A6P00661 POLY CHANNEL
(x2)



A6P00690 DUST SEAL TAPE

NOTES:

1. INSTALL DUST TAPE ON TOP & BOTTOM ON EACH POLY SHEETING.
 - CUT (2) STRIPS OF DUST SEAL TAPE THE SAME WIDTH AS THE POLY SHEETING.
 - WRAP DUST SEAL TAPE ALONG EDGE OF POLY SHEETING WIDTH.
2. PUSH CHANNEL ON OVER THE POLY SHEETING.
 - CENTER CHANNEL ON SHEET WITH APPROXIMATELY 15/16" (24mm) CLEARANCE ON EACH SIDE OF POLY SHEET AS SHOWN.
3. REPEAT FOR BOTH (2) ROOF SHEETS.

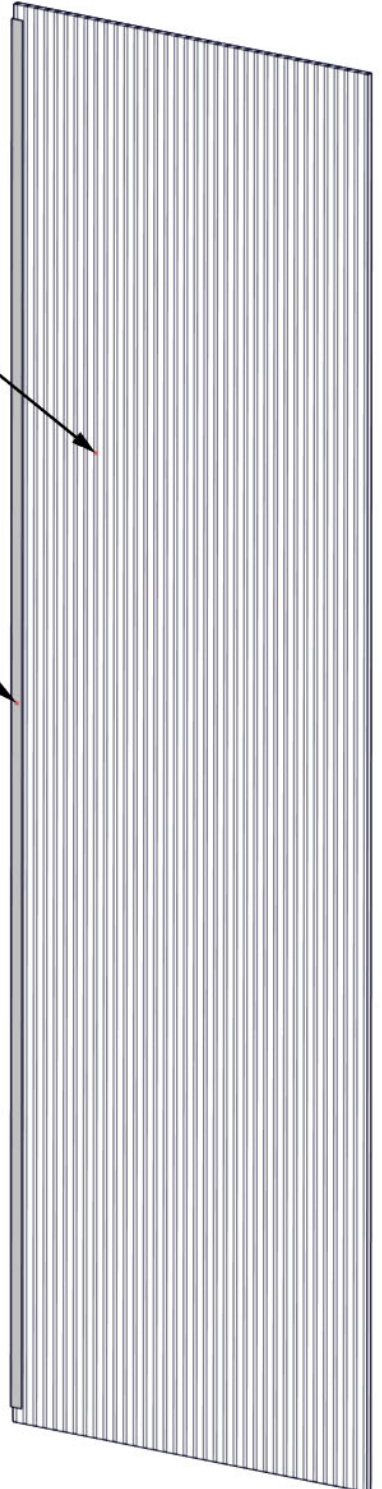

660 (x1)
POLY ROOF SHEET

690 (x2)
DUST SEAL TAPE

661 (x1)
POLY CHANNEL

NO DUST SEAL
TAPE ON SIDES

STEP 83 - ROOF ASSEMBLY

NOTES:

- SLIDE ROOF ASSEMBLIES INTO POLY SHEET SPLICES ON ROOF AS SHOWN.
- PUSH UNTIL BOTTOM IS FLUSH WITH FRONT OF FASCIA.
- IMPORTANT! ENSURE UV SIDE OF POLY SHEETING IS FACING OUTSIDE.
- SAFE TO REMOVE PROTECTIVE FILM IMMEDIATELY BEFORE INSTALLATION.

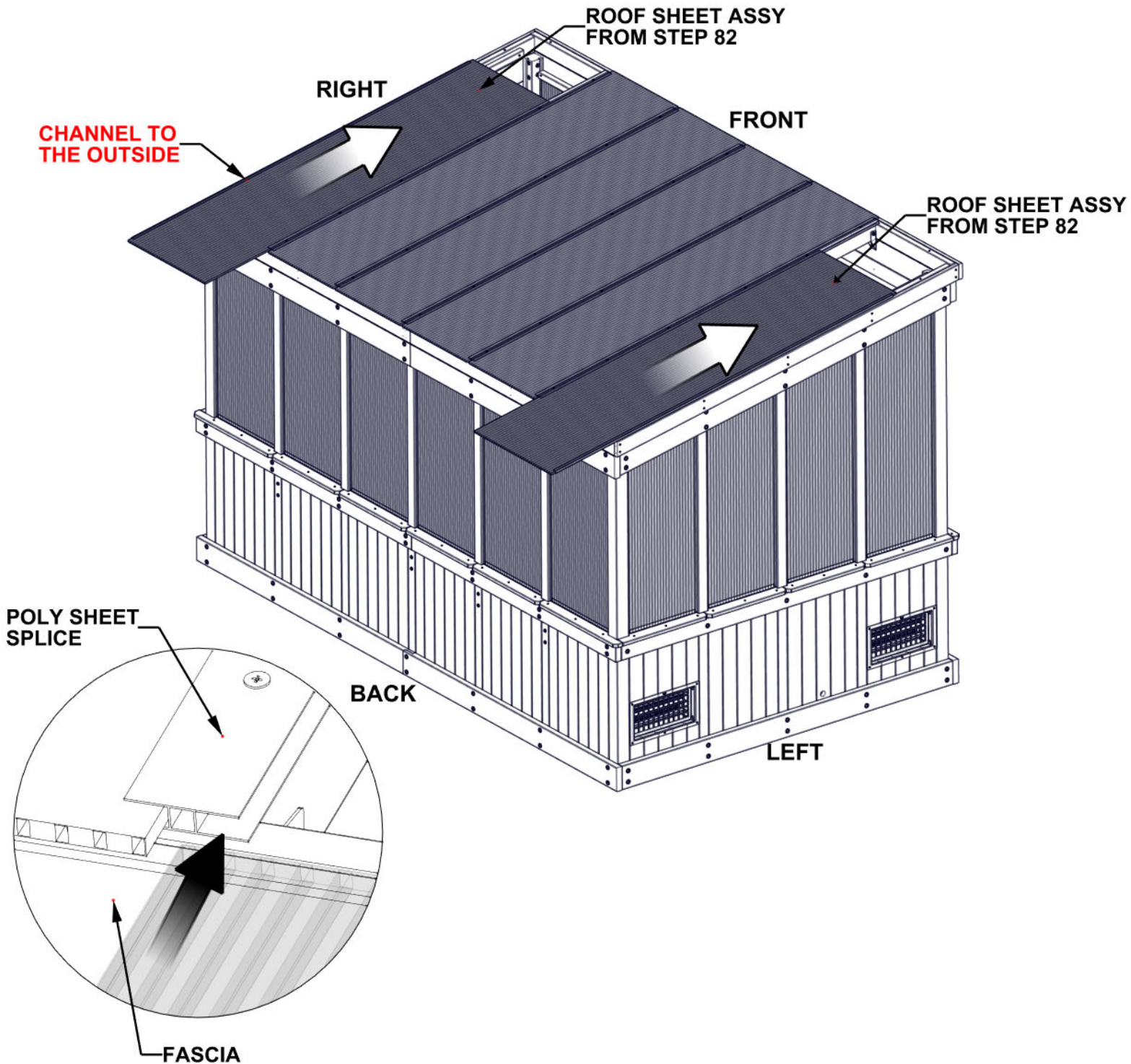

STEP 84 - ROOF ASSEMBLY



A4M02514 SPLICE COVER
(x5)

NOTES:

- SLIDE TABS ON SPLICE COVER OVER THE TABS ON THE CHANNEL.
- SLIDE COVER UP UNTIL THE BOTTOM OF THE SPLICE IS FLUSH WITH BOTTOM OF THE CHANNEL.

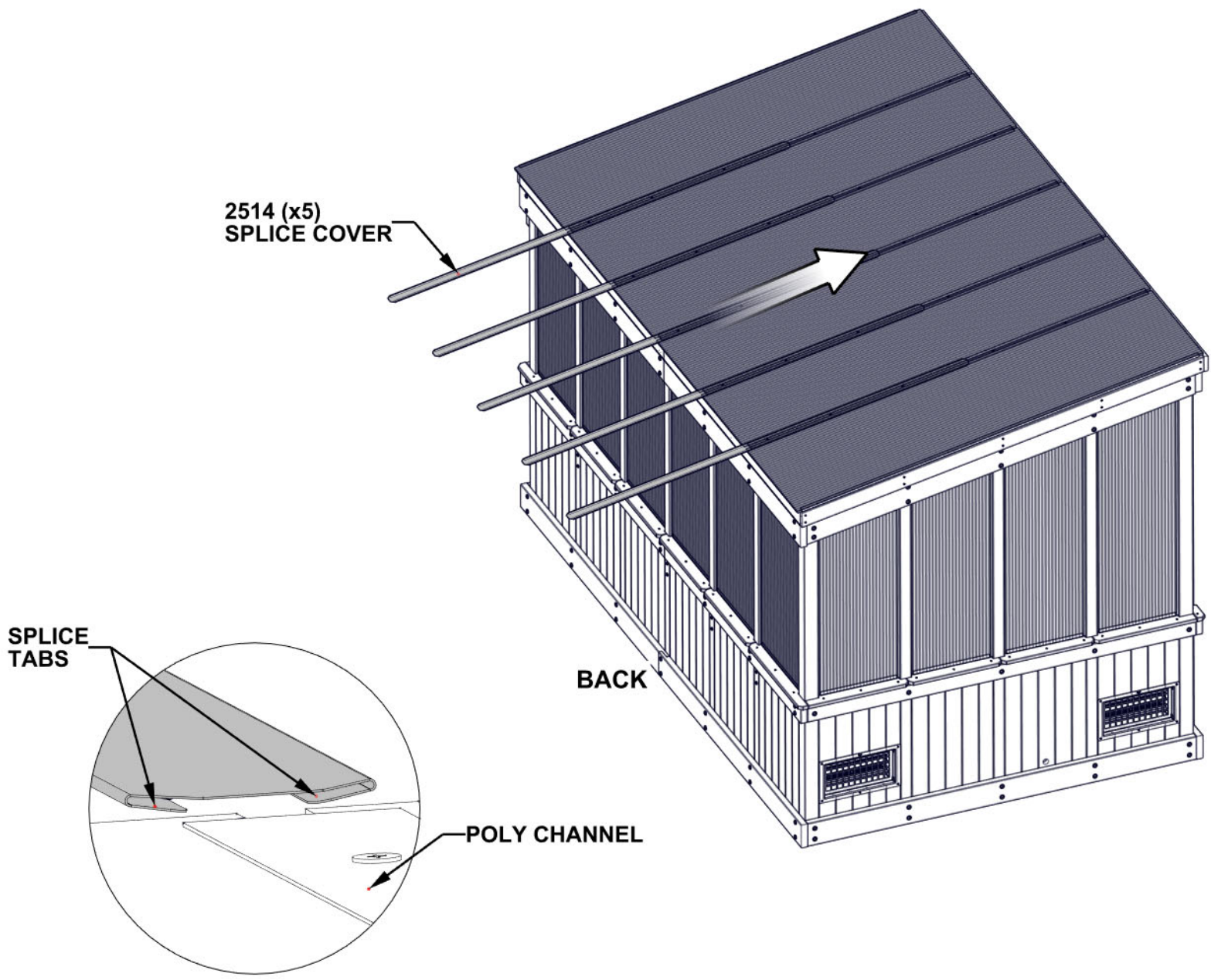

STEP 85 - ROOF ASSEMBLY

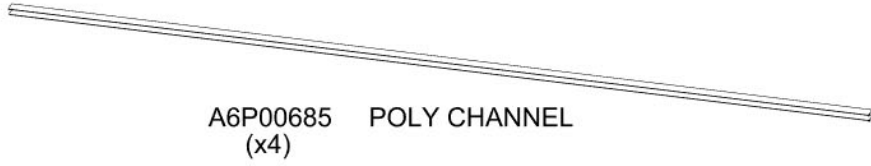

NOTE:
SLIDE EACH CHANNEL OVER THE
FRONT & BACK OF 3 ROOF SHEETS.

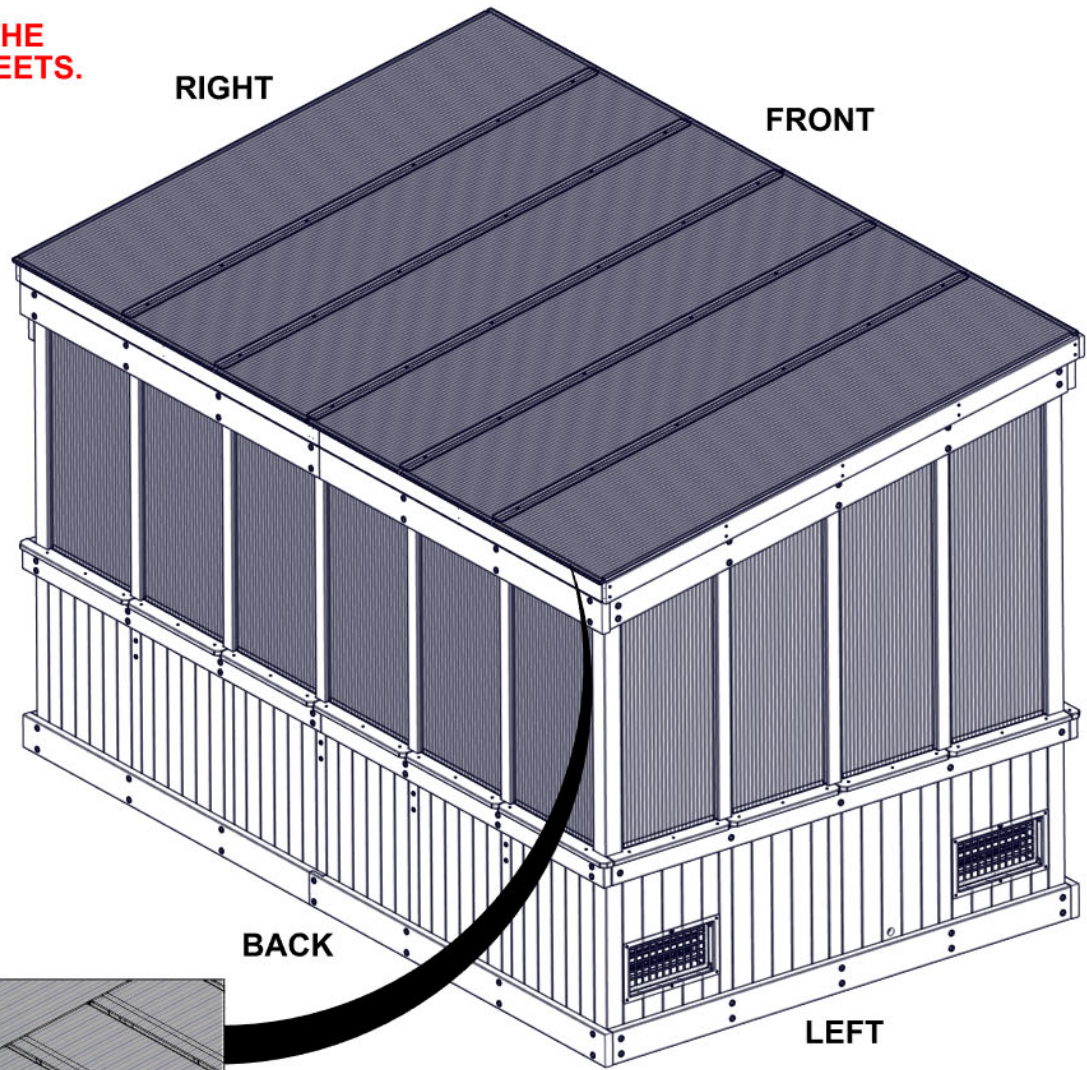

685 (x4)
POLY CHANNEL

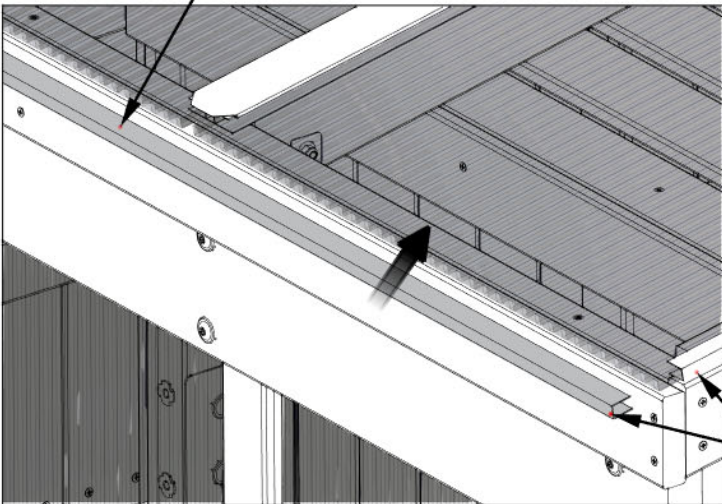

**MAKE SURE THE END OF THE 685
CHANNEL IS FLUSH WITH THE
CHANNEL EDGE ON EACH SIDE**

STEP 86 - FASCIA

Qty	PART NUMBER	DESCRIPTION
12	H100391	SCREW PFH 8 X 2 BLK



H01 FASCIA - W4L18671
(x2) 15/16"X3 3/8"X71 9/16" (24x86x1817)

NOTES:
ALIGN HOLES IN FASCIA WITH PILOT
HOLES ON HEADER & ATTACH AS SHOWN.

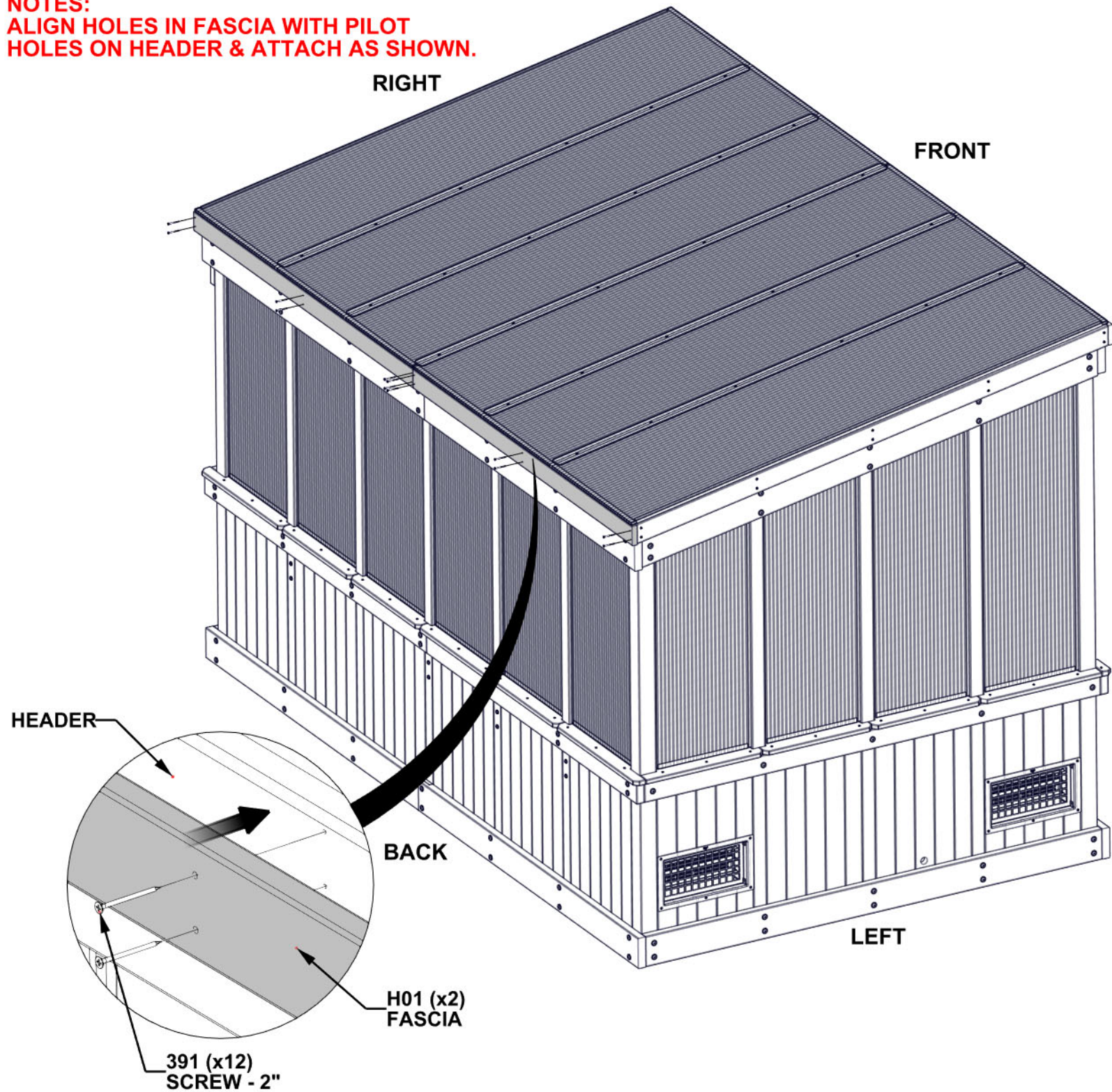

STEP 87 - EDGE TRIM

Qty	PART NUMBER	DESCRIPTION
11	H101206	SCREW WOODGRIP 10-16x1-1/4"

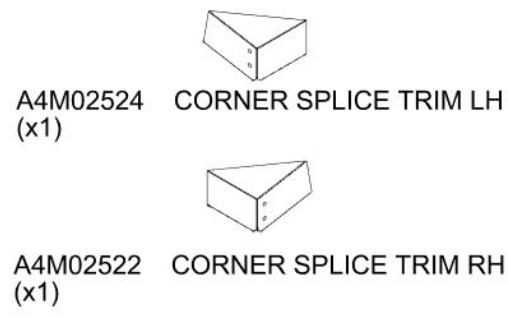
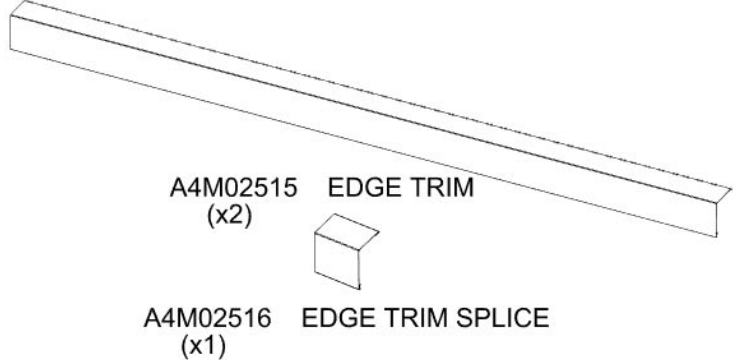

WARNING: GLOVES ARE RECOMMENDED WHEN HANDLING STEEL

NOTES:
REMOVE BLUE FILM FROM EDGE TRIM, EDGE TRIM SPLICE, AND CORNER SPLICE TRIM.

- STEP 2**
- SCREWS ARE TO BE INSERTED IN THE MIDDLE OF SHEETS AND MIDDLE OF SPLICE COVERS.
 - SCREWS WILL BE PLACE 1 1/2" [38mm] AWAY FROM FRONT OF EDGE TRIM.

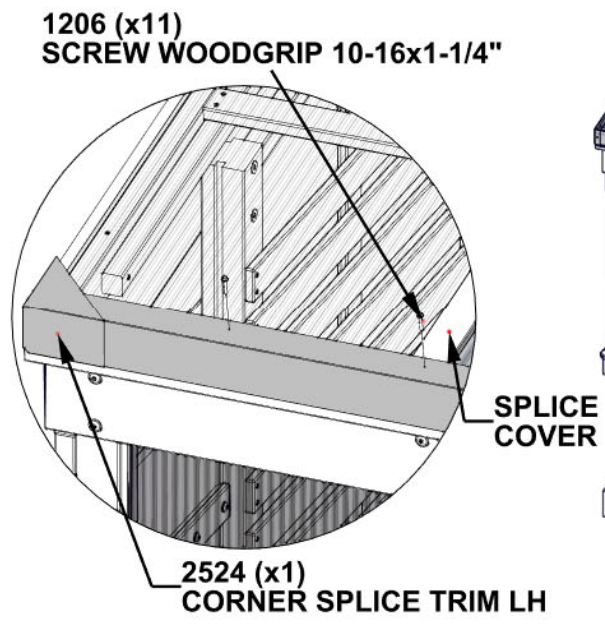
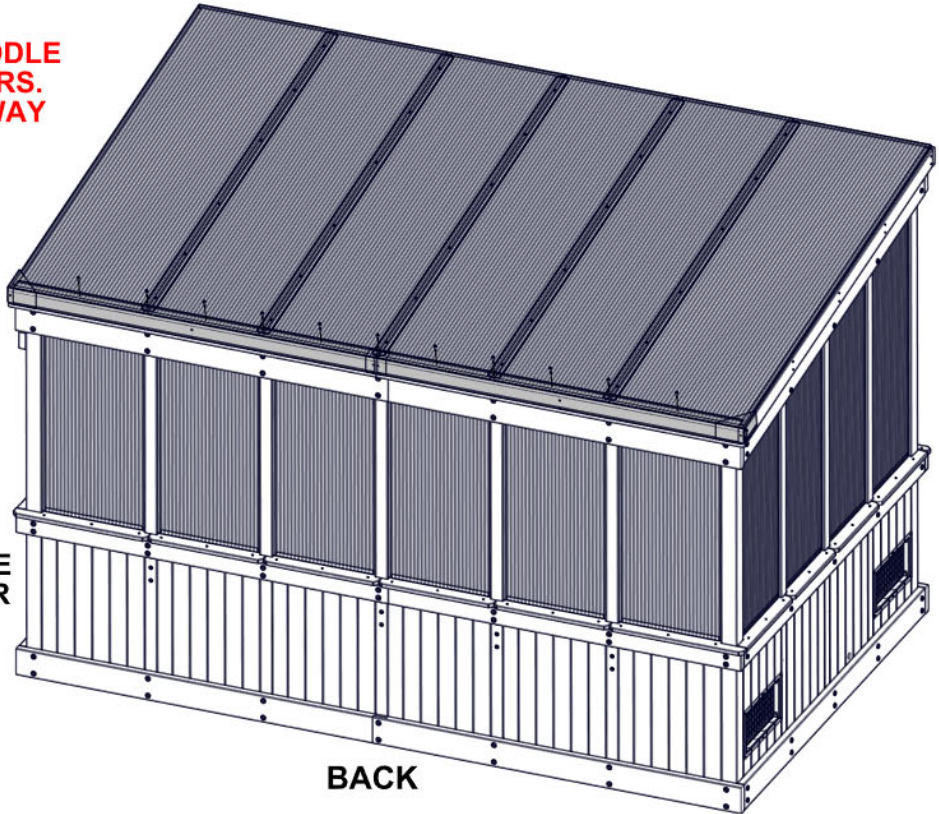

- STEP 1**
- ORIENT EDGE TRIM, EDGE TRIM SPLICE, AND CORNER SPLICE TRIM AS SHOWN BELOW.
 - SLIDE TRIM PIECES INTO SPLICES. ATTACH CORNER SPLICES BY SLIDING ONTO EDGE TRIM.

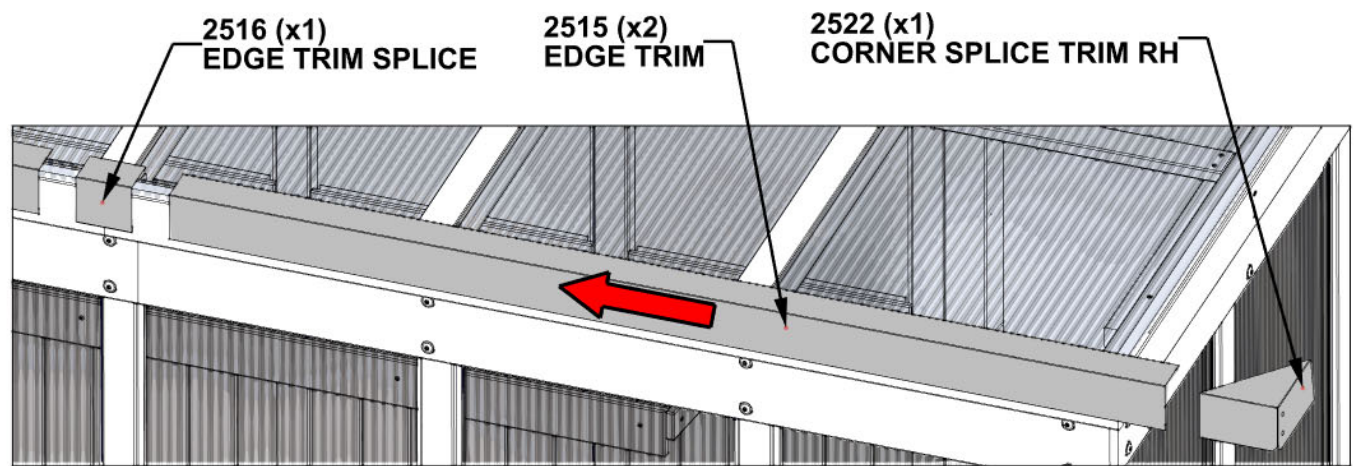

STEP 88 - EDGE TRIM

Qty	PART NUMBER	DESCRIPTION
5	H101206	SCREW WOODGRIP 10-16x1-1/4"

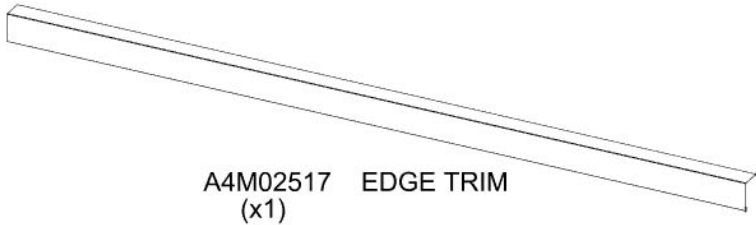

WARNING: GLOVES ARE RECOMMENDED WHEN HANDLING STEEL

NOTES:
REMOVE BLUE FILM FROM EDGE TRIM & CORNER SPLICE TRIM.

- STEP 2**
- SCREWS ARE TO BE INSERTED IN THE MIDDLE OF PURLINS.
 - SCREWS WILL BE PLACE 1 1/2" [38mm] AWAY FROM FRONT OF EDGE TRIM.
 - SCREWS FOR THE STEP 86 CORNER SPLICE WILL BE INSERTED THROUGH CORNER SPLICE & EDGE TRIM AS SHOWN.

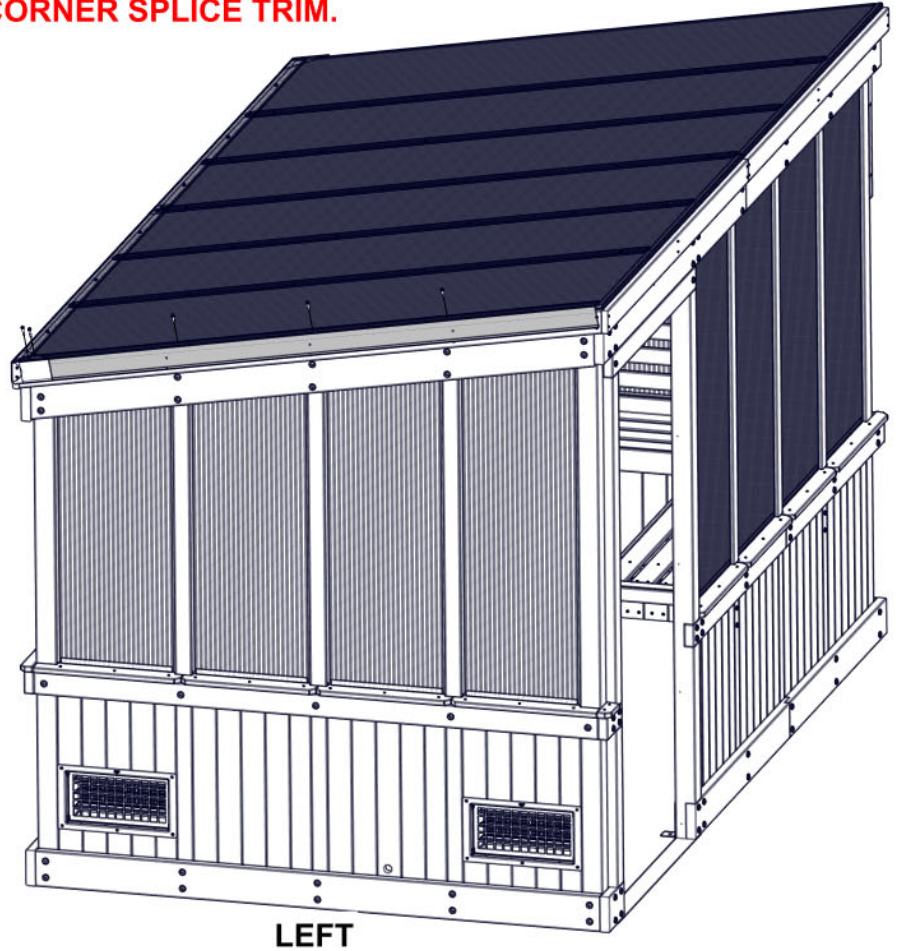
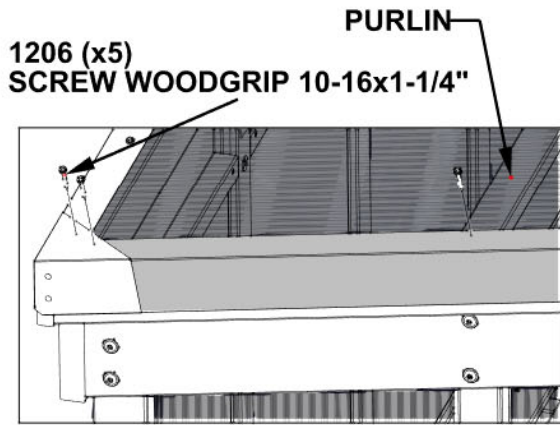

- STEP 1**
- ORIENT EDGE TRIM AS SHOWN BELOW.
 - SLIDE TRIM PIECE INTO CORNER SPLICE.

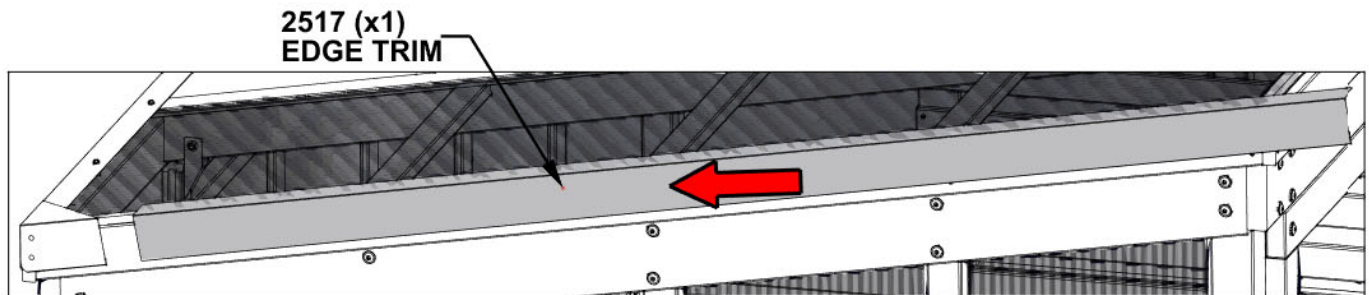

STEP 89 - EDGE TRIM

Qty	PART NUMBER	DESCRIPTION
5	H101206	SCREW WOODGRIP 10-16x1-1/4"

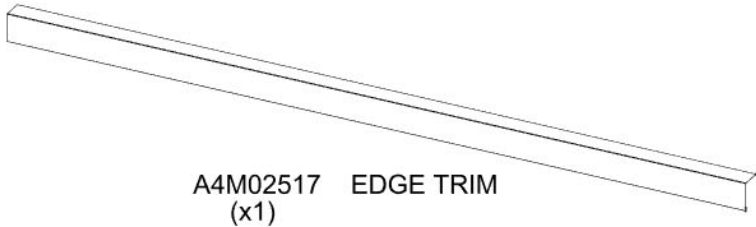

WARNING: GLOVES ARE RECOMMENDED WHEN HANDLING STEEL

**NOTES:
REMOVE BLUE FILM FROM EDGE TRIM & CORNER SPLICE TRIM.**

STEP 2

- SCREWS ARE TO BE INSERTED IN THE MIDDLE OF PURLINS.
- SCREWS WILL BE PLACE 1 1/2" [38mm] AWAY FROM FRONT OF EDGE TRIM.
- SCREWS FOR THE STEP 86 CORNER SPLICE WILL BE INSERTED THROUGH CORNER SPLICE & EDGE TRIM AS SHOWN.

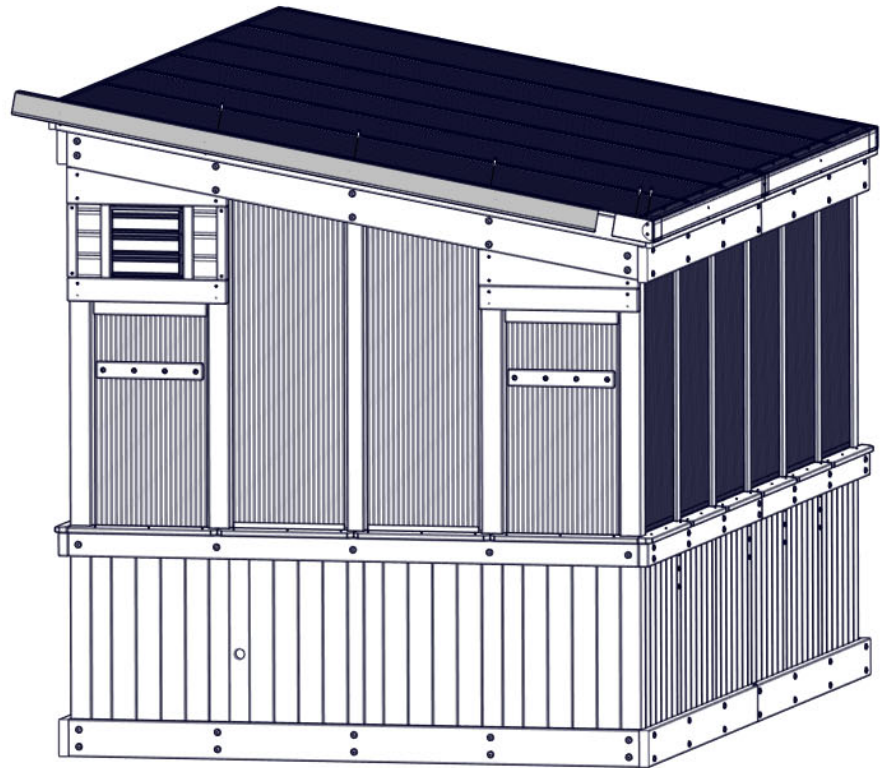

RIGHT

PURLIN 1206 (x5)
SCREW WOODGRIP 10-16x1-1/4"

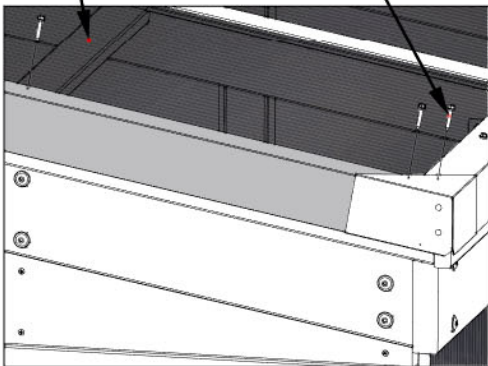

STEP 1

- ORIENT EDGE TRIM AS SHOWN BELOW.
- SLIDE TRIM PIECE INTO CORNER SPLICE.

2517 (x1)
EDGE TRIM

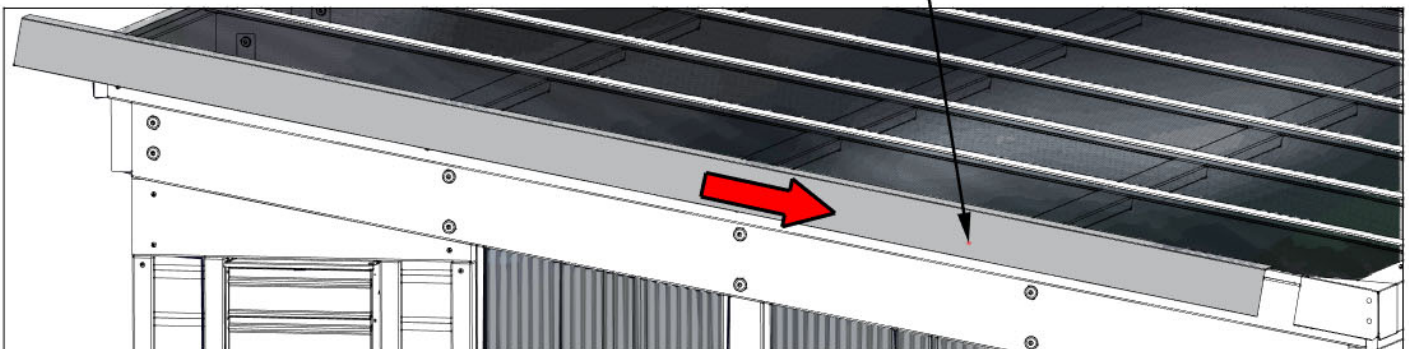

STEP 90 - EDGE TRIM

Qty	PART NUMBER	DESCRIPTION
15	H101206	SCREW WOODGRIP 10-16x1-1/4"

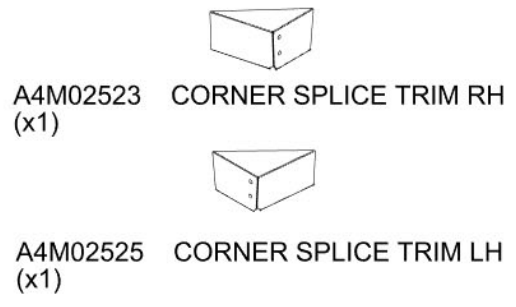
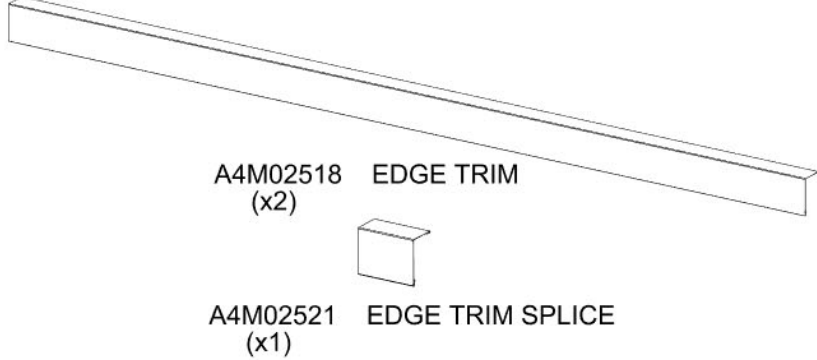

WARNING: GLOVES ARE RECOMMENDED WHEN HANDLING STEEL

NOTES:
REMOVE BLUE FILM FROM EDGE TRIM, EDGE TRIM SPLICE, AND CORNER SPLICE TRIM.

- STEP 2**
- SCREWS ARE TO BE INSERTED IN THE MIDDLE OF SHEETS AND MIDDLE OF SPLICE COVERS.
 - SCREWS WILL BE PLACE 1 1/2" [38mm] AWAY FROM FRONT OF EDGE TRIM.

1206 (x15)
 SCREW WOODGRIP 10-16x1-1/4"

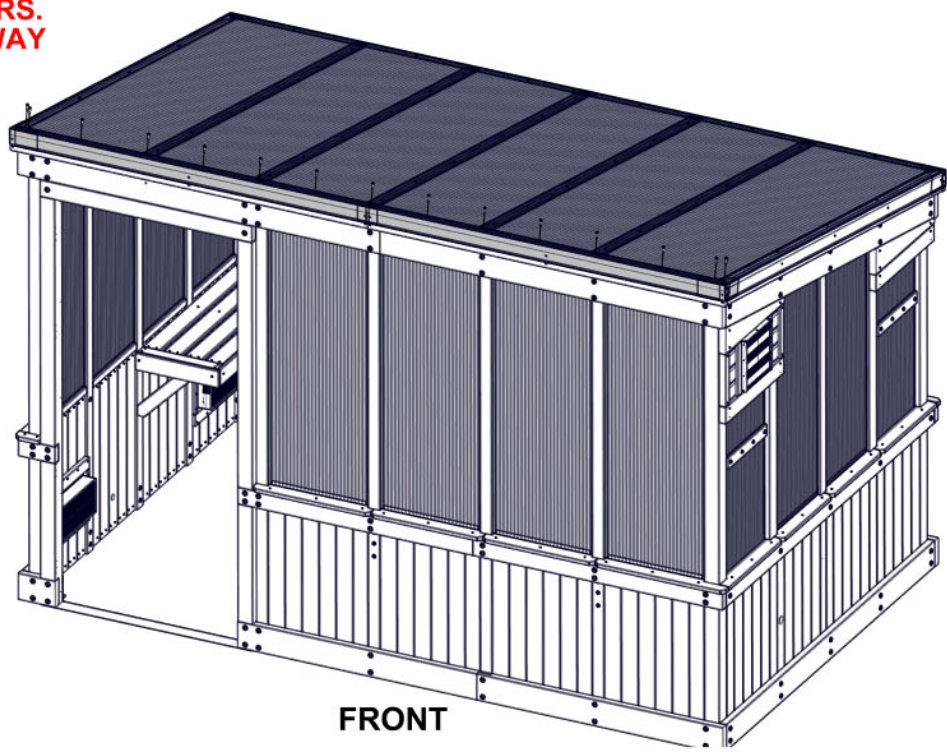
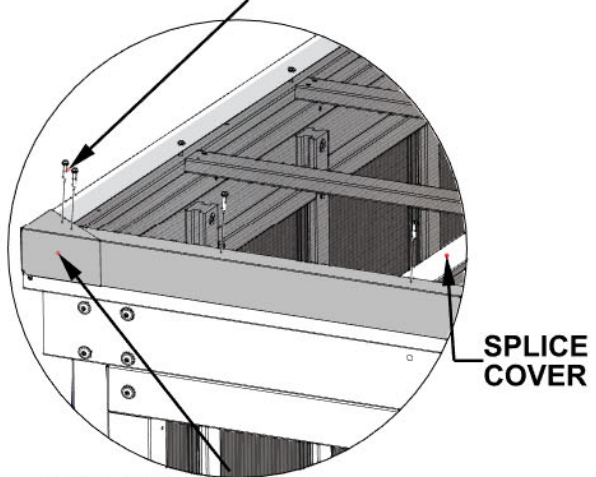

2525 (x1)
 CORNER SPLICE TRIM LH

- STEP 1**
- ORIENT EDGE TRIM, EDGE TRIM SPLICE, AND CORNER SPLICE TRIM AS SHOWN BELOW.
 - SLIDE TRIM PIECES INTO SPLICES. ATTACH CORNER SPLICES BY SLIDING ONTO EDGE TRIM.

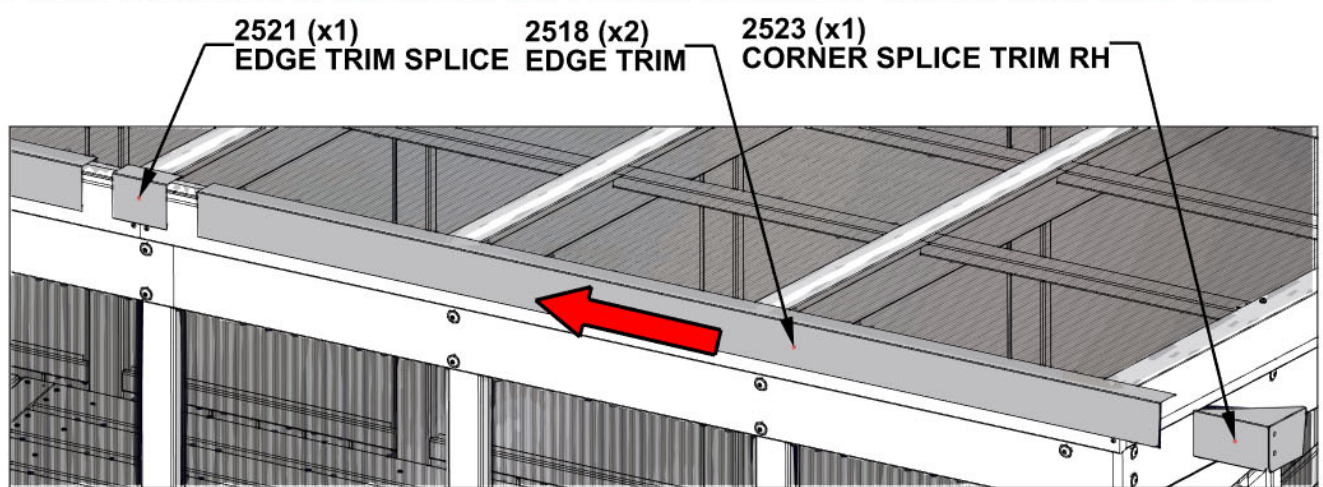

STEP 91A - DOOR ASSEMBLY

Qty	PART NUMBER	DESCRIPTION
12	H100385	SCREW PFH 8 X 1 BLK

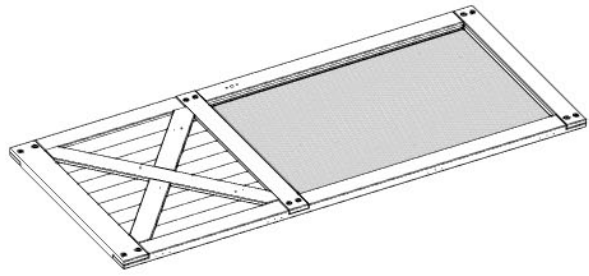

DA01 DOOR ASSEMBLY - W2A03986
(x1) 1 7/8"x35 13/16"x80" (48x910x2032)

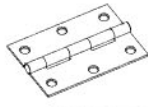

A4M00557 HINGE ASSEMBLY
(x4)

NOTES:
ALIGN HOLES ON HINGES WITH PILOT HOLES ON DOOR.

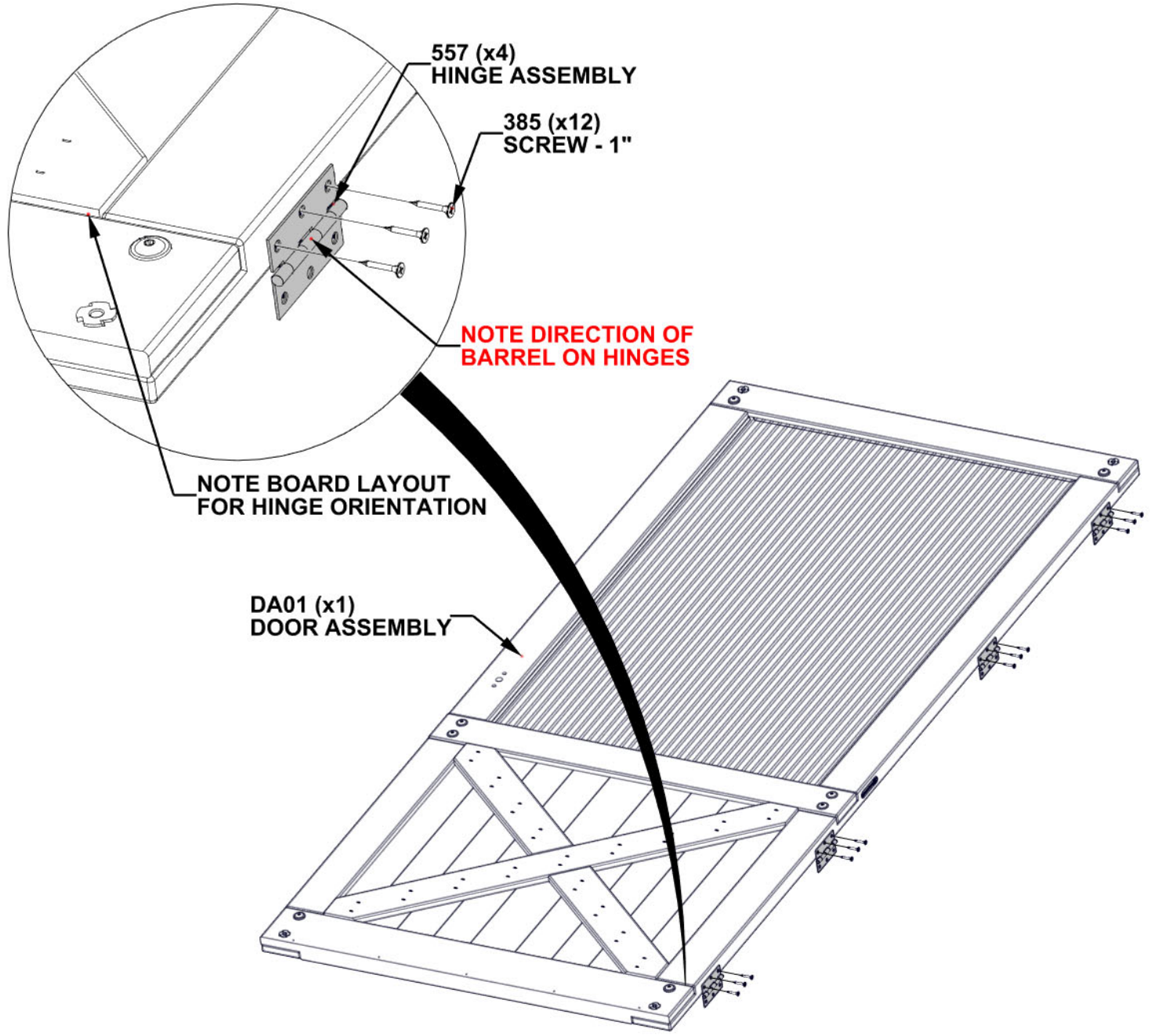

STEP 91B - DOOR ASSEMBLY

Qty	PART NUMBER	DESCRIPTION
2	H101259	SCREW POH 8x1 1/4 BLK

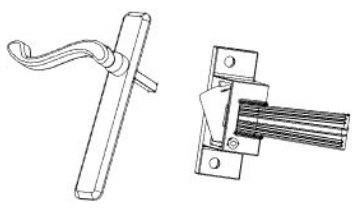

A4M02410 STORM DOOR HANDLE
(x1)

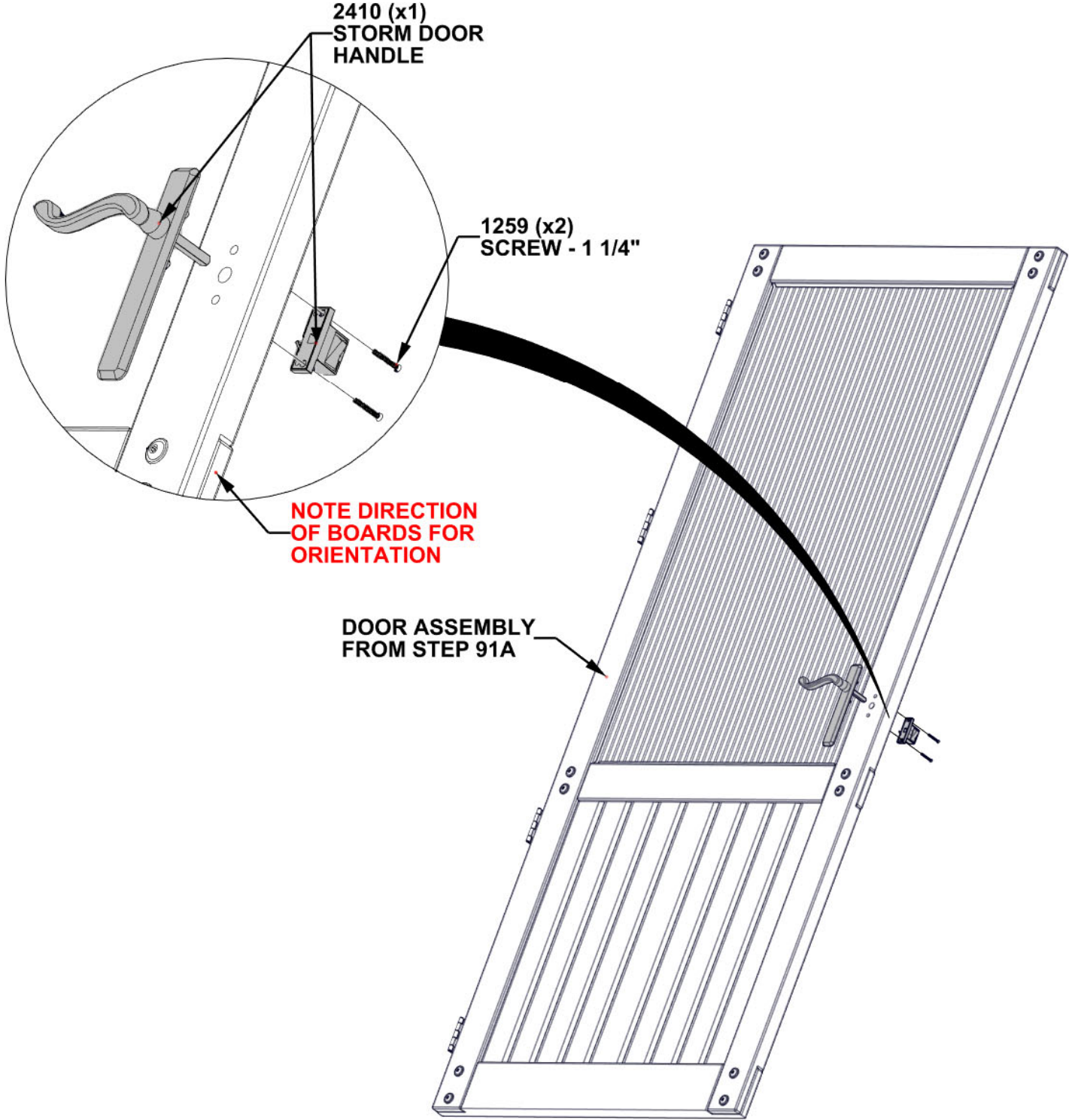

STEP 91C - DOOR ASSEMBLY

Qty	PART NUMBER	DESCRIPTION
5	H100797	SCREW PWH 8 X 1 BLK

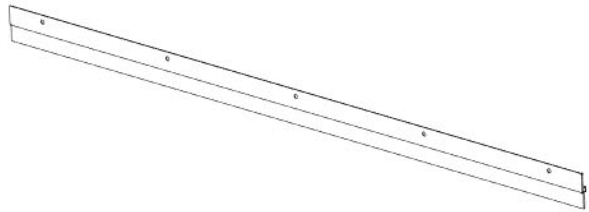

A6P00710 DOOR SWEEP
(x1)

- NOTES:**
- CENTER DOOR SWEEP ON DOOR.
 - FASTEN AS SHOWN

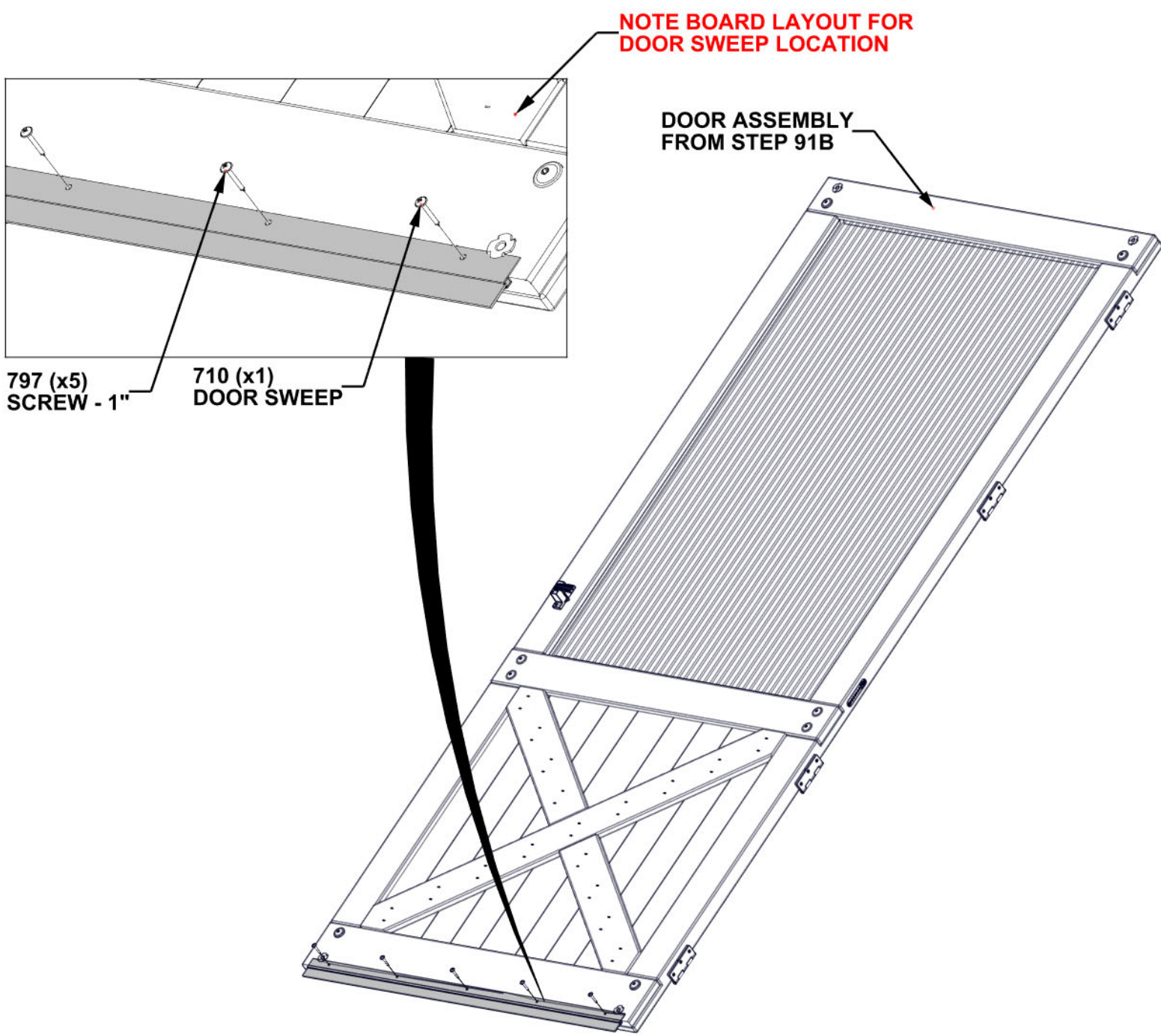

STEP 92 - DOOR ASSEMBLY

Qty	PART NUMBER	DESCRIPTION
12	H100385	SCREW PFH 3 X 1 BLK

- NOTES:**
- ALIGN HINGES ON DOOR ASSEMBLY WITH PILOT HOLES ON UPRIGHT.
 - ATTACH AS SHOWN.

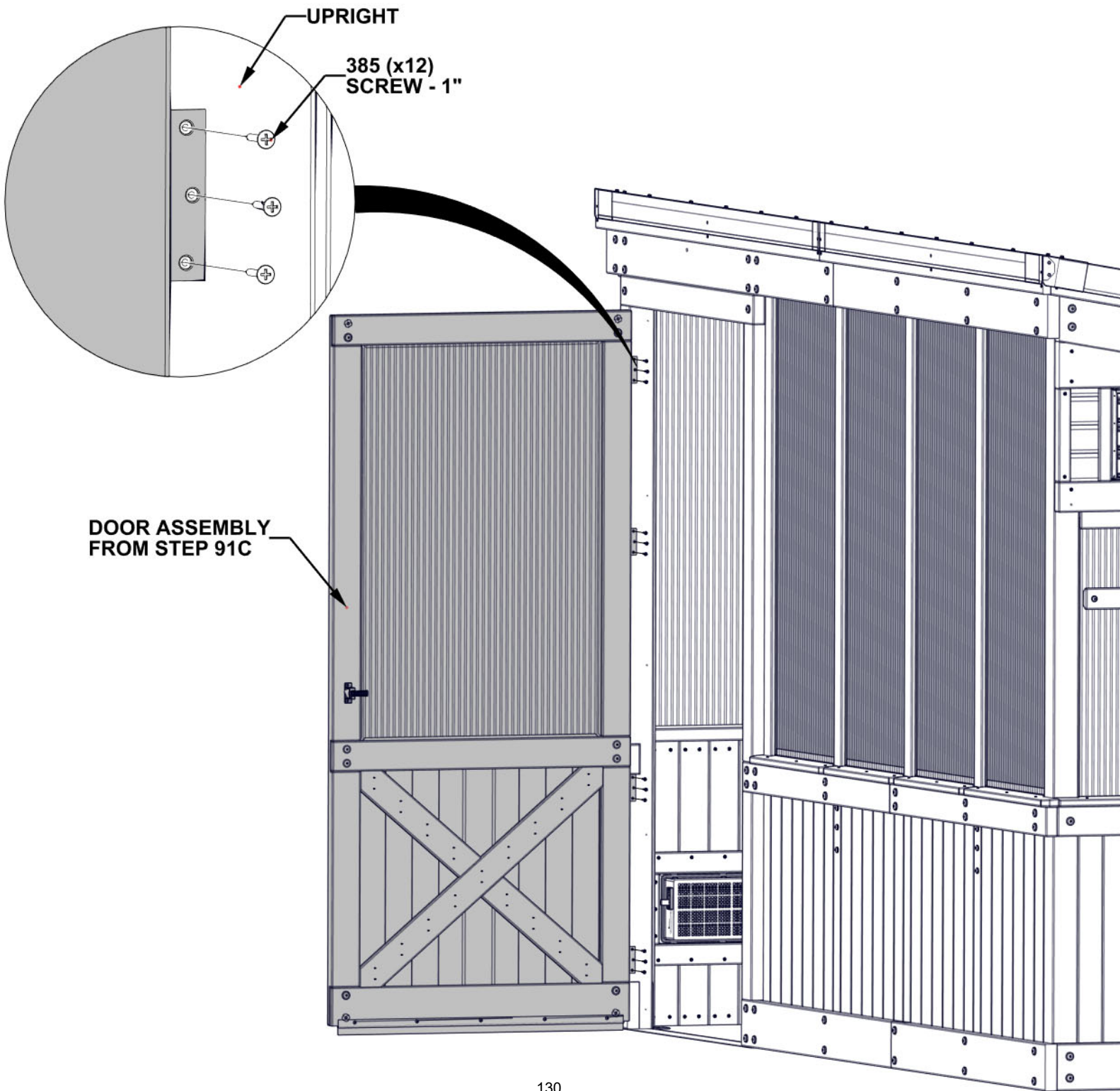

STEP 93 - DOOR ASSEMBLY

Qty	PART NUMBER	DESCRIPTION
13	H100391	SCREW PFH 8 X 2 BLK



F13 DOOR TRIM - W4L18727
 (x1) 1 7/16"x1 7/16"x36 9/16" (36x60x928)



P02 DOOR TRIM - W4L18728
 (x2) 15/16"x1 7/16"x79 15/16" (24x36x2030)

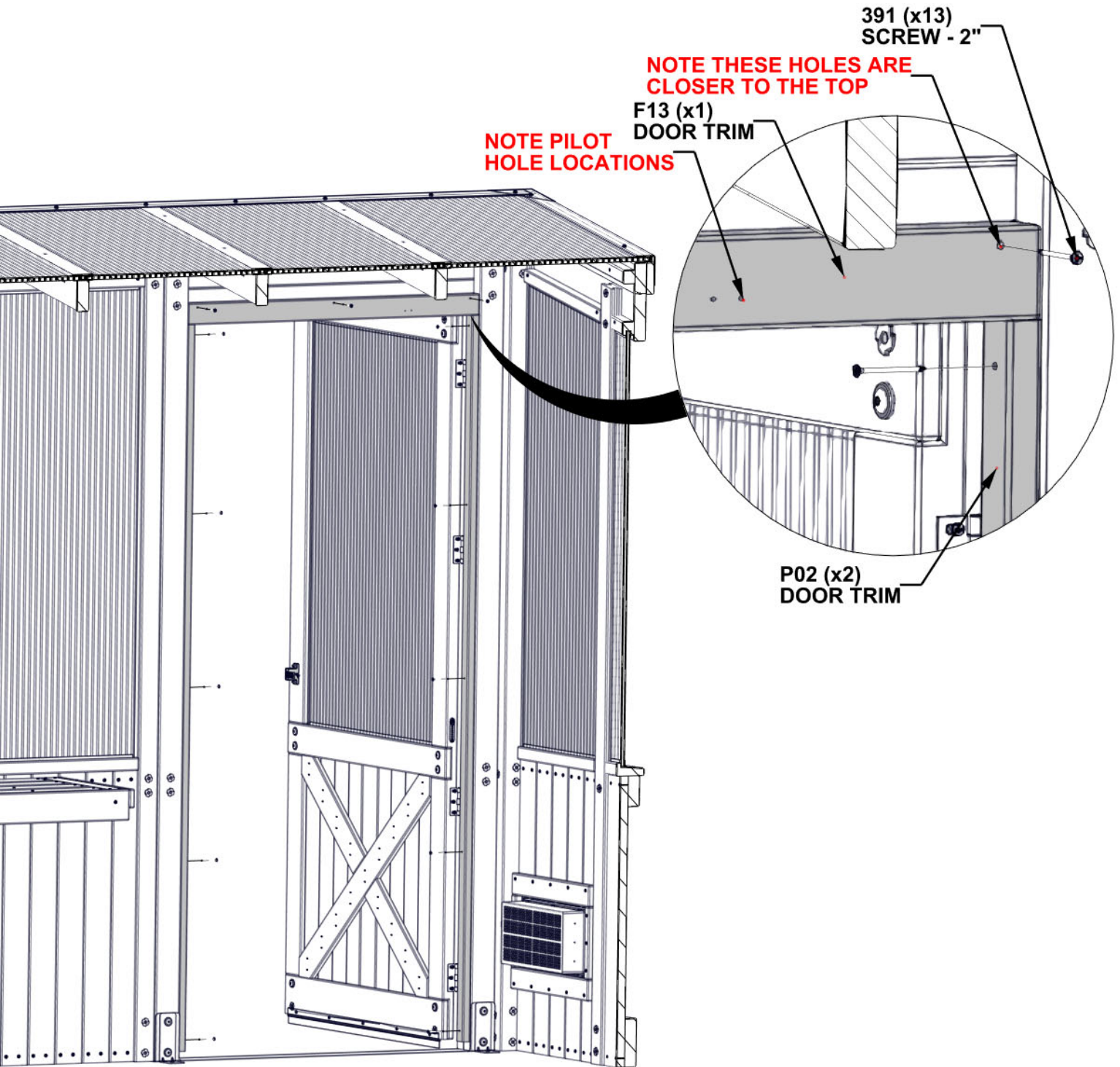

BACK WALL & TABLES NOT SHOWN ON THIS STEP

STEP 94A - DOOR ASSEMBLY

Qty	PART NUMBER	DESCRIPTION
4	H100392	SCREW PWH 8 X 3/4 BLK



A4M02411 DOOR PROTECTOR CHAIN (x1)

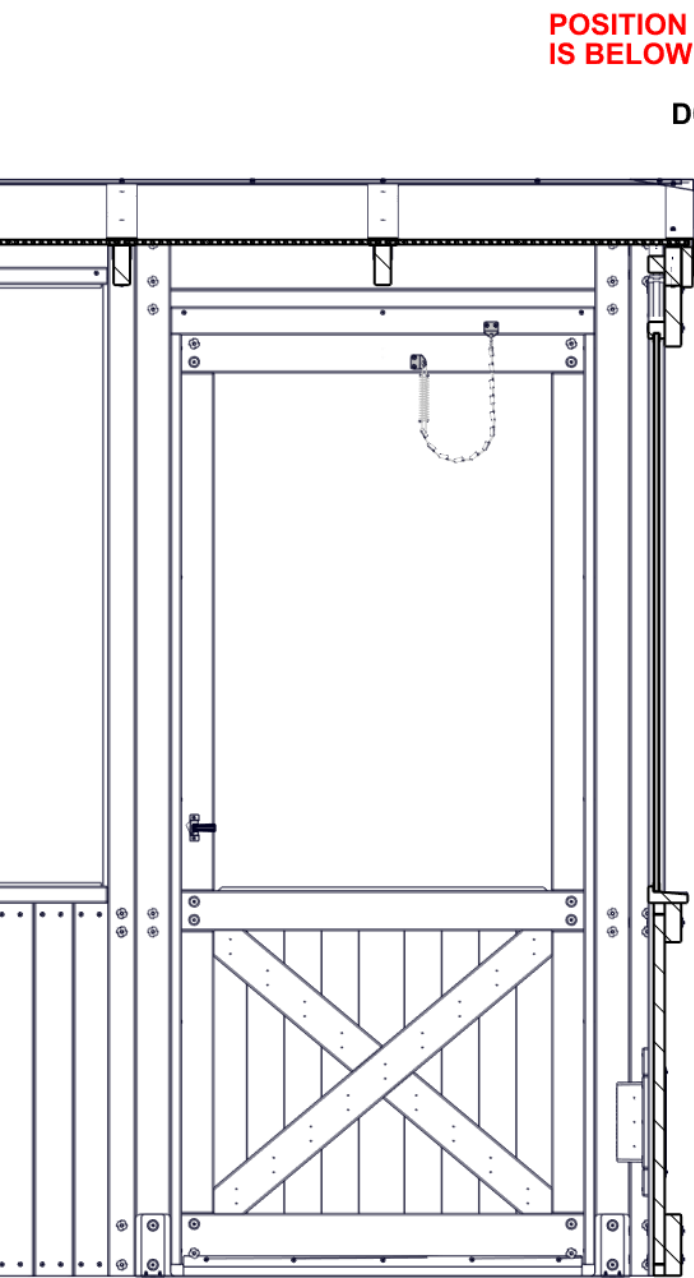

BACK WALL & TABLES NOT SHOWN ON THIS STEP

2411 (x1) DOOR PROTECTOR CHAIN

POSITION SO THAT CHAIN IS BELOW THE DOOR STOP

DOOR STOP

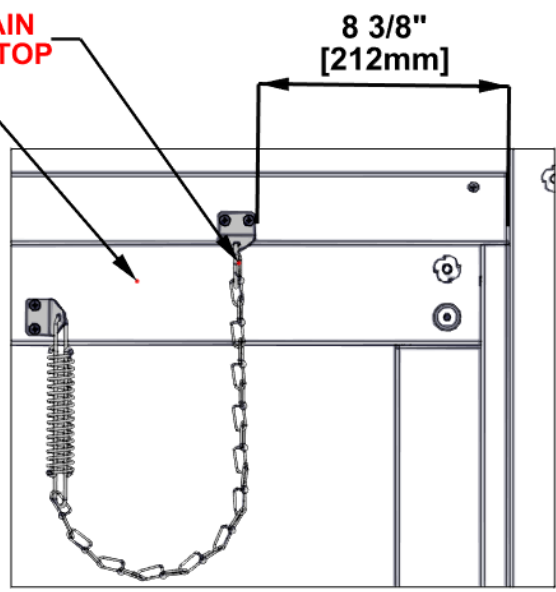

8 3/8" [212mm]

ALIGN DOOR CHAIN BRACKETS WITH PILOT HOLES

392 (x4) SCREW - 3/4"



STEP 94B - DOOR ASSEMBLY

Qty	PART NUMBER	DESCRIPTION
2	H101260	SCREW PRH 8x1 1/4 SS

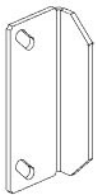

A4M02410 LATCH
(x1)

NOTES:

- HOLD DOOR SHUT AND POSITION LATCH PLATE WHERE IT SECURES DOOR HANDLE LATCH WHEN DOOR IS CLOSED.
- MARK AND USE 1/8" DRILL BIT TO CREATE PILOT HOLES.
- ATTACH AS SHOWN.

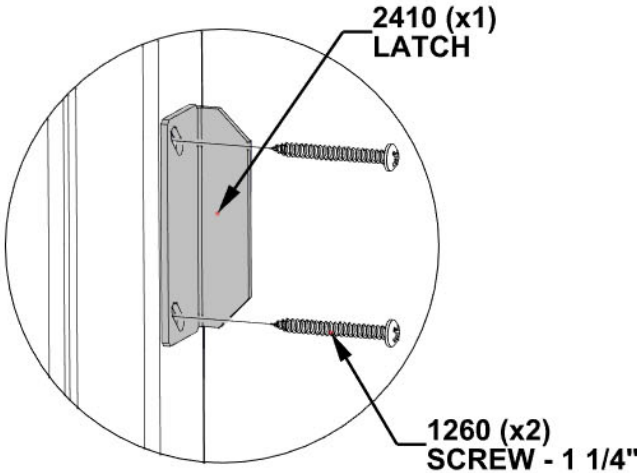
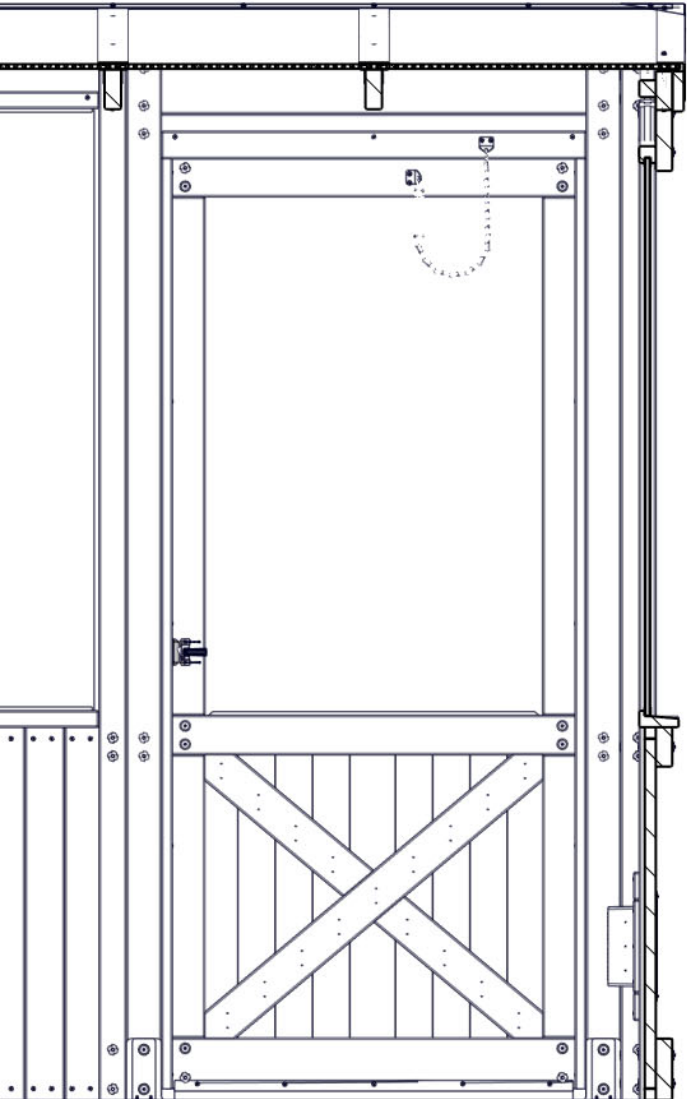
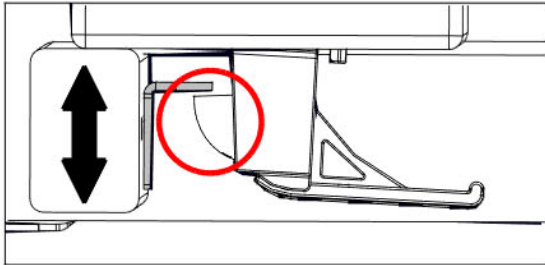
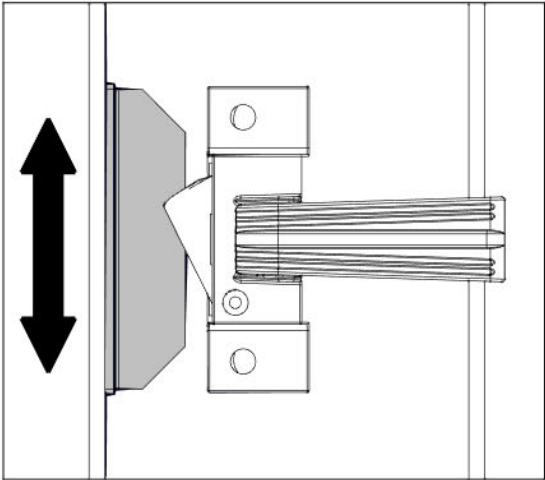

BACK WALL & TABLES NOT SHOWN ON THIS STEP

STEP 95A - ELECTRIC

Qty	PART NUMBER	DESCRIPTION
2	H100203	SCREW PFH 8 X 1/2 BLK
2	H100385	SCREW PFH 8 X 1 BLK

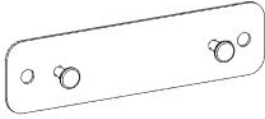

A4M01292 MOUNTING BRACKET
(x2) (INCLUDED W/ ELECTRICAL ENCLOSURE)

- NOTES:**
- USE AN 1/8" DRILL BIT TO CREATE PILOT HOLES; USING MOUNTING BRACKETS & DIMENSIONS AS A GUIDE.
 - ATTACH AS SHOWN.

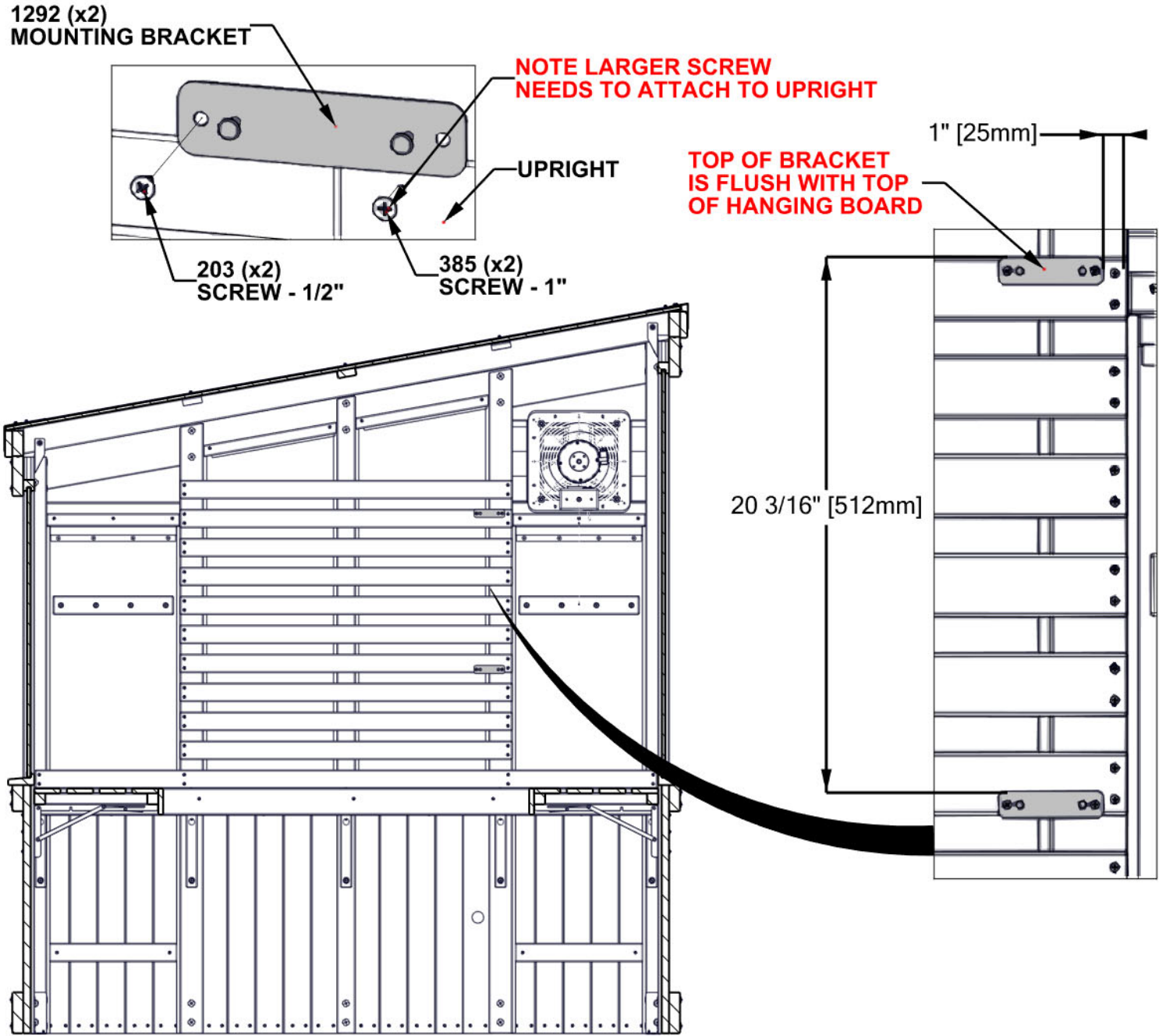

**LEFT WALL NOT
SHOWN ON THIS STEP**

STEP 95B - ELECTRIC

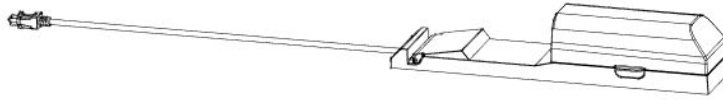

9205413 ELECTRICAL ENCLOSURE
(x1)

NOTES:

- HANG ELECTRICAL ENCLOSURE ON THE MOUNTING BRACKETS PROVIDED IN STEP 95A.
- RUN CHORD BEHIND THE SLAT WALL TOWARDS ACCESS HOLE IN WALL PANEL UNDER TABLE.

**WARNING! KEEP AWAY FROM WATER.
RISH OF ELECTRIC SHOCK!**

SEE ELECTRIC ENCLOSURE MANUAL
FOR COMPLETE DETAILS.

413 (x1)
ELECTRICAL ENCLOSURE

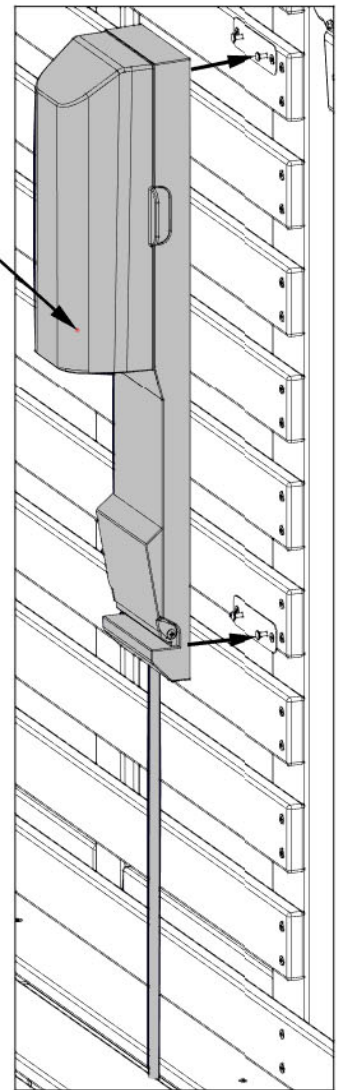
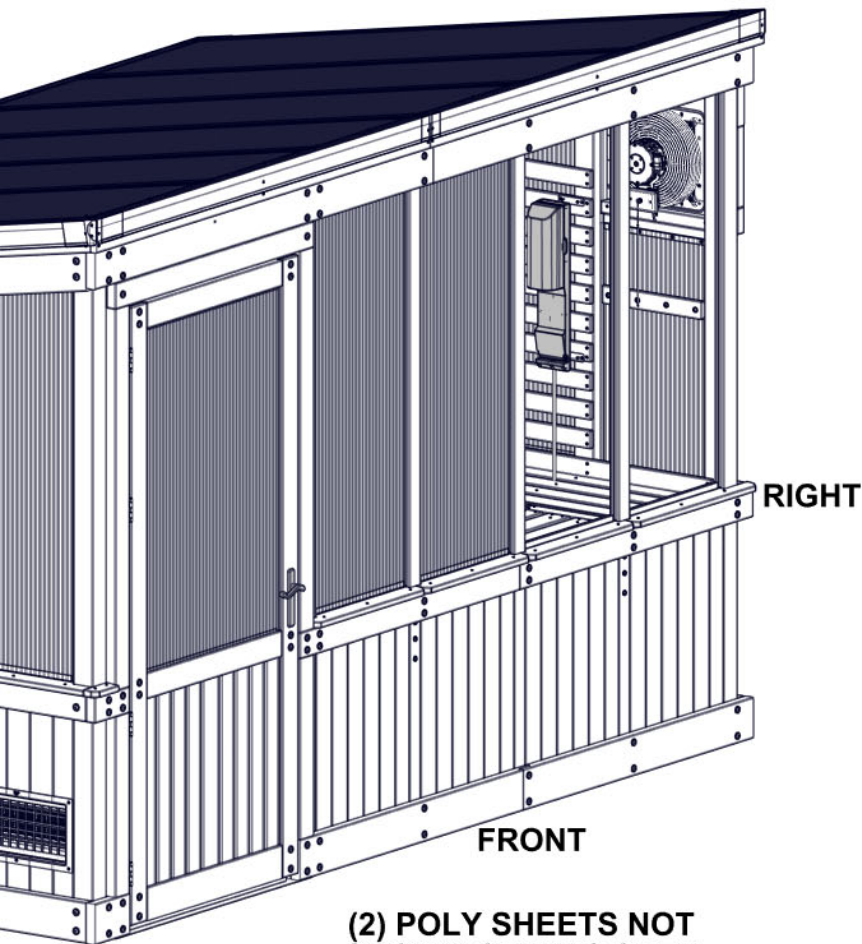

(2) POLY SHEETS NOT
SHOWN ON THIS STEP

STEP 96 - ELECTRICAL

Qty	PART NUMBER	DESCRIPTION
1	H100411	SCREW PFH 8 X 5/8 BLK



A6P00754 THERMOSTAT
(x1)

- NOTES:**
- LOCATE THERMOSTAT IN A DESIRED LOCATION CLOSE TO THE ELECTRICAL ENCLOSURE.
 - INSTALL SCREW LEAVING IT PARTIALLY STICKING OUT AND HANG THERMOSTAT.
 - HANG THE PROBE IN AN ELEVATED LOCATION.

SEE THERMOSTAT MANUAL FOR OPERATING INSTRUCTIONS

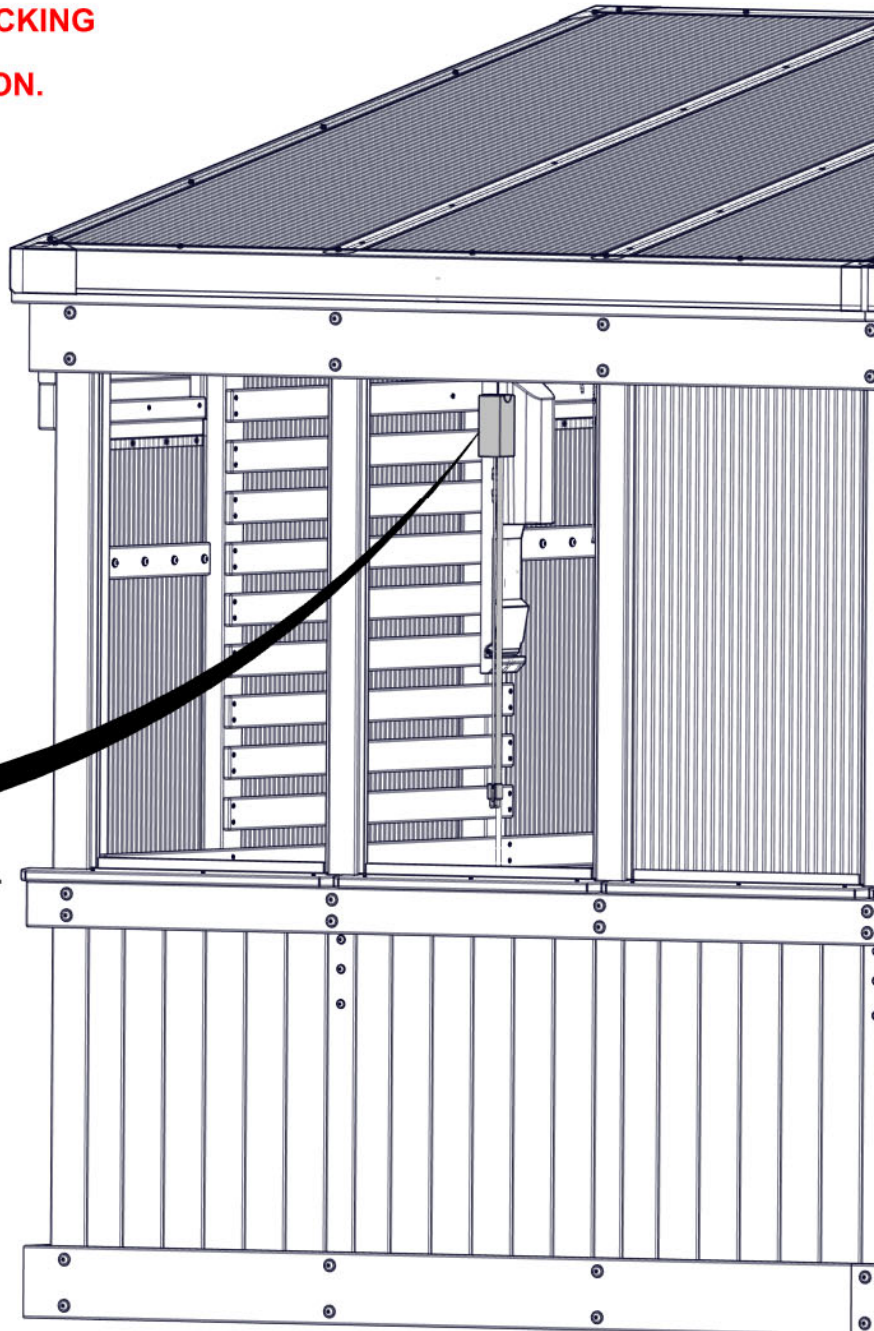
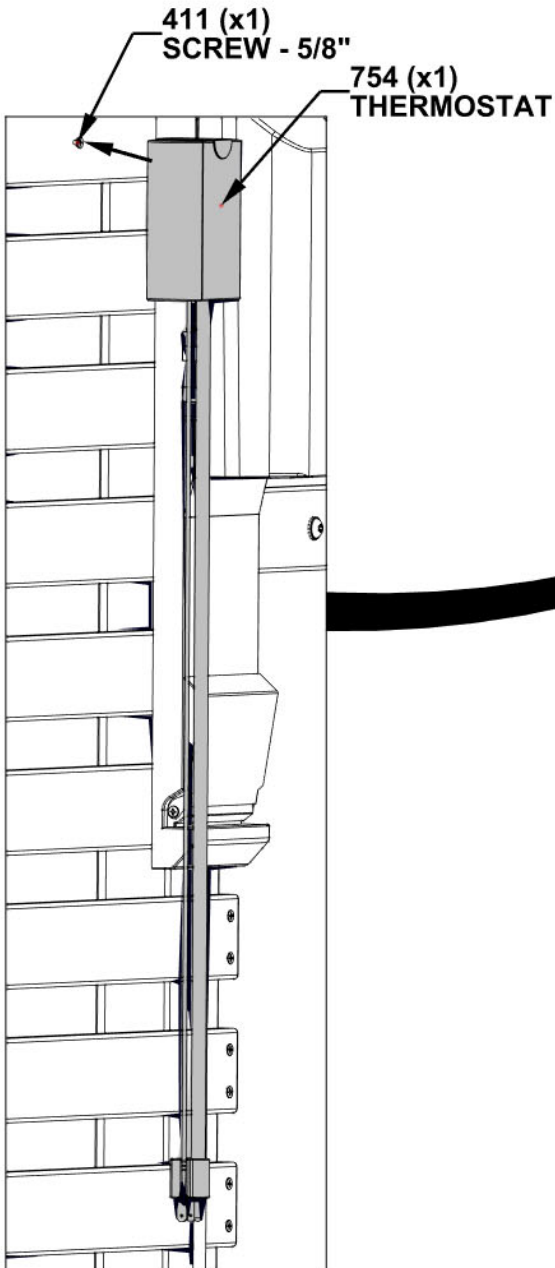

RIGHT

(2) POLY SHEETS NOT SHOWN ON THIS STEP **BACK**

STEP 97 - ELECTRICAL

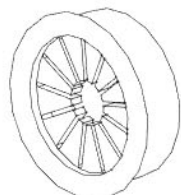

A6P00692 CORD GROMMET
(x1)

NOTES:
INSERT GROMMET IN HOLE PROVIDED
ON RIGHT SIDE OF GREENHOUSE.

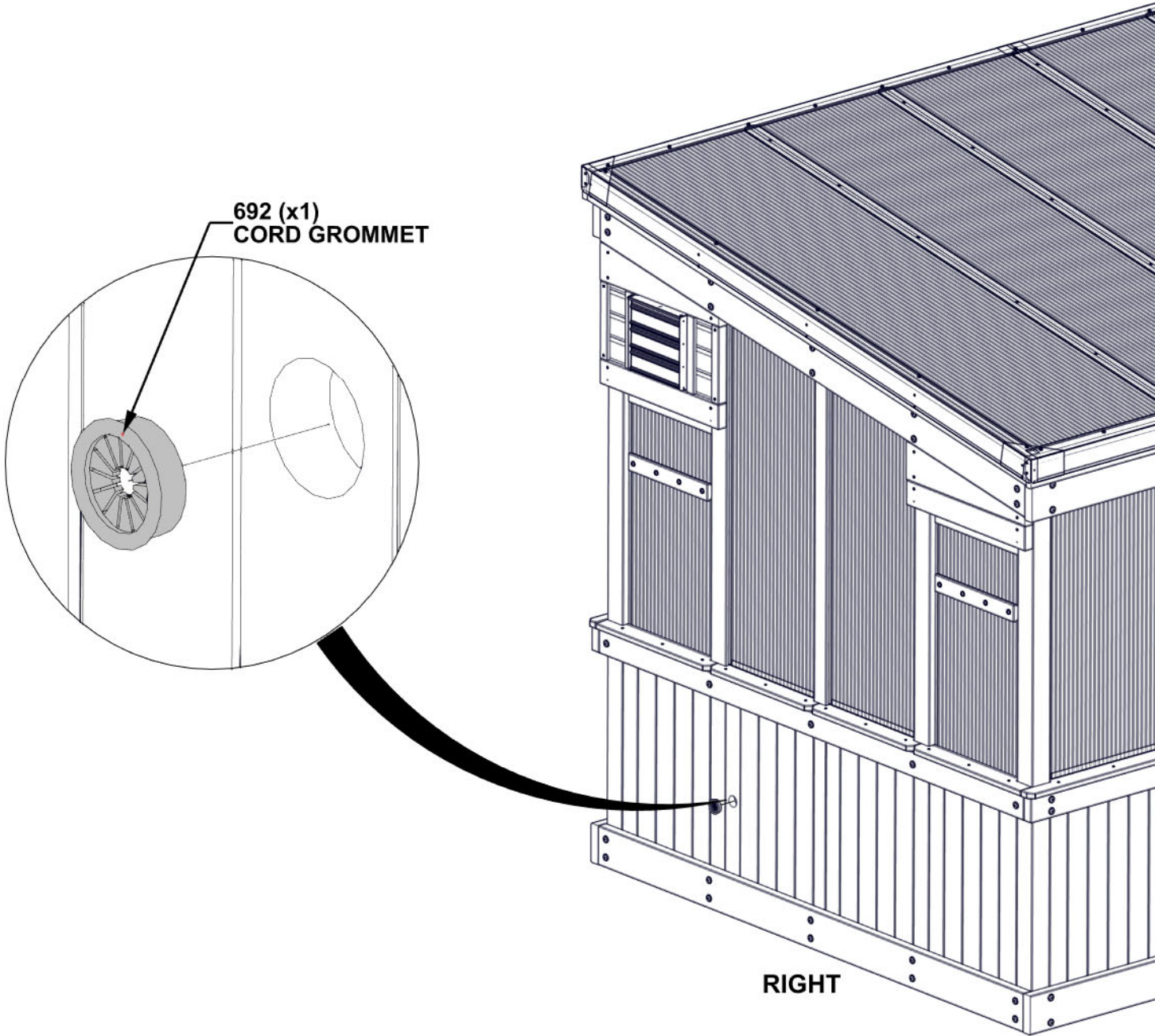

STEP 98 - WATER LINE

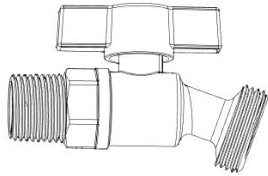

A4M02384 HOSE FAUCET
(x1)

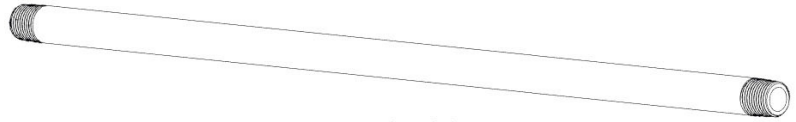

A6P00645 PIPE 1/2" SCH40 X 24"
(x1)

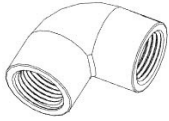

A6P00646 ELBOW 1/2" NPT
(x2)

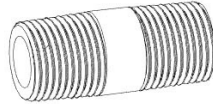

A6P00649 THREADED PIPE CONNECTOR
(x1)



A6P00809 PLUMBERS TAPE

- NOTES:**
- USE PLUMBERS TAPE AND WRAP THREADS OF MALE FITTINGS.
 - FASTEN FITTINGS TO FORM THE COMPLETED WATER LINE ASSEMBLY BELOW.

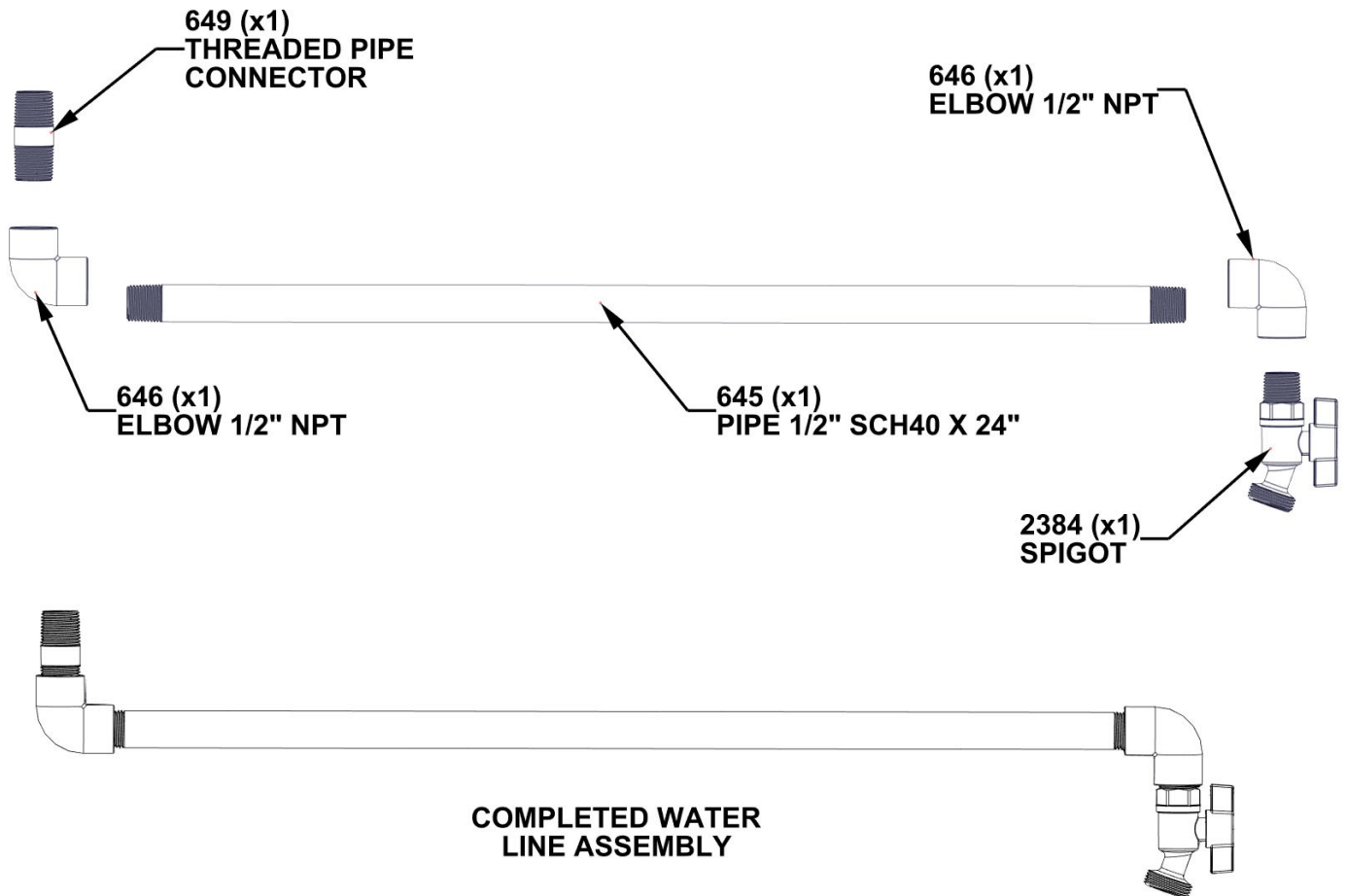

STEP 99 - WATER LINE

Qty	PART NUMBER	DESCRIPTION
4	H100387	SCREW PFH 8 X 1 1/4 BLK



M10 WATER LINE BOARD - W4L18820
(x1) 5/8"x3 3/8"x20 15/16" (16x86x532)

- NOTES:**
- USE DIMENSIONS SHOW TO LOCATE WATER LINE BOARD.
 - USE AN 1/8" DRILL BIT AND WATER LINE BOARD TO CREATE PILOT HOLES.
 - ATTACH AS SHOWN.

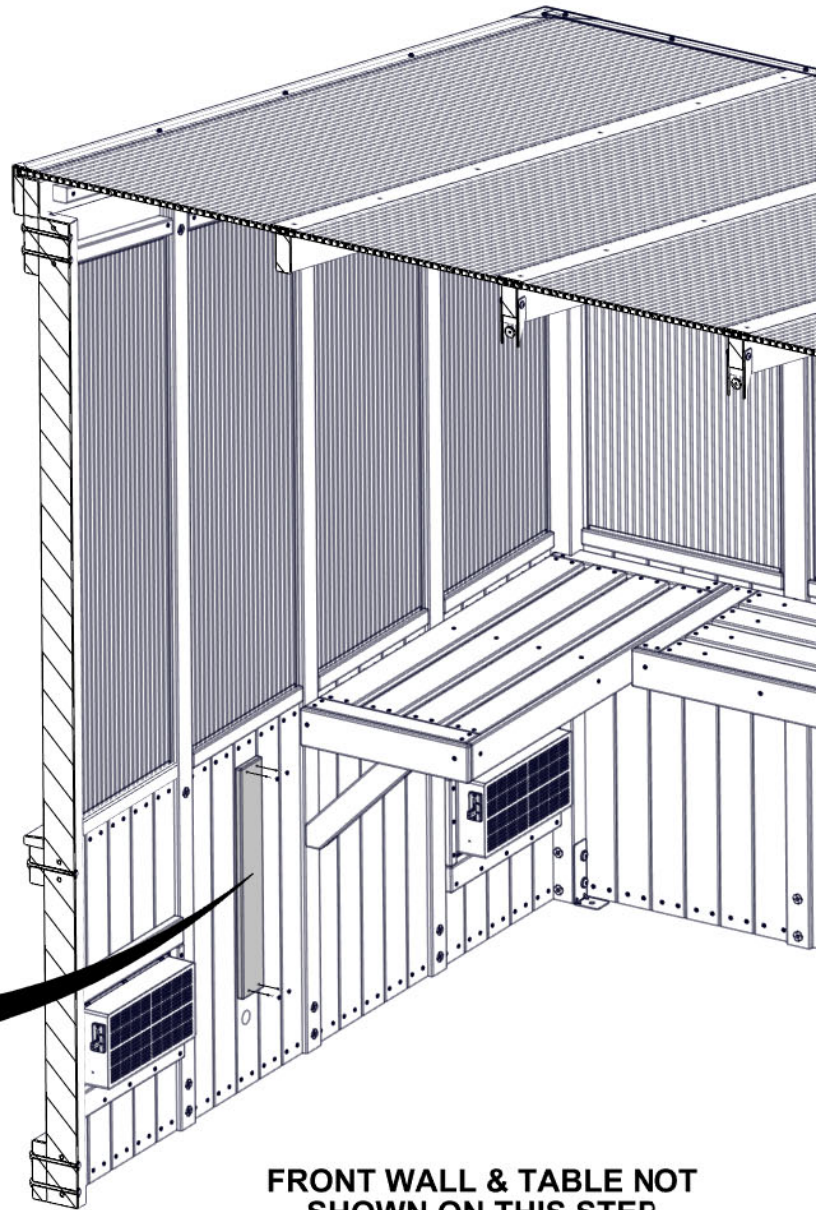
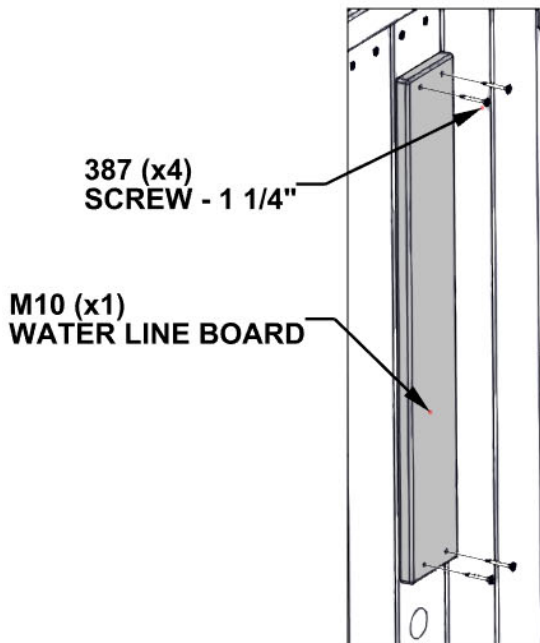
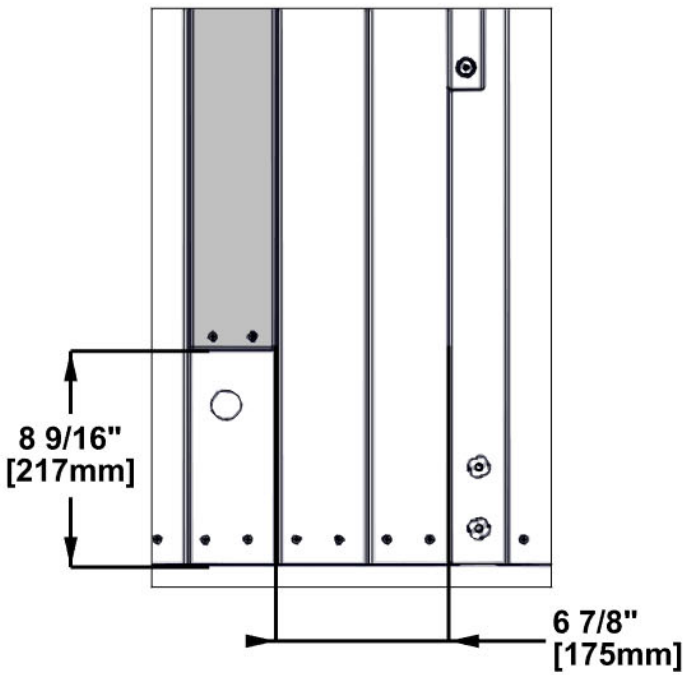

FRONT WALL & TABLE NOT SHOWN ON THIS STEP

STEP 100 - WATER LINE

Qty	PART NUMBER	DESCRIPTION
2	H100395	SCREW PFH 8 X 3/4 BLK

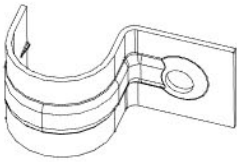

A4M02385 PIPE CLAMP
(x2)

- NOTES:**
- INSERT WATER LINE ASSEMBLY THROUGH THE HOLE IN THE SIDE WALL.
 - SECURE WATER LINE TO WATER LINE BOARD WITH PIPE CLAMPS.
 - FASTEN CLAMPS USING DIMENSIONS AS A GUIDE AT BOTH THE TOP & BOTTOM.

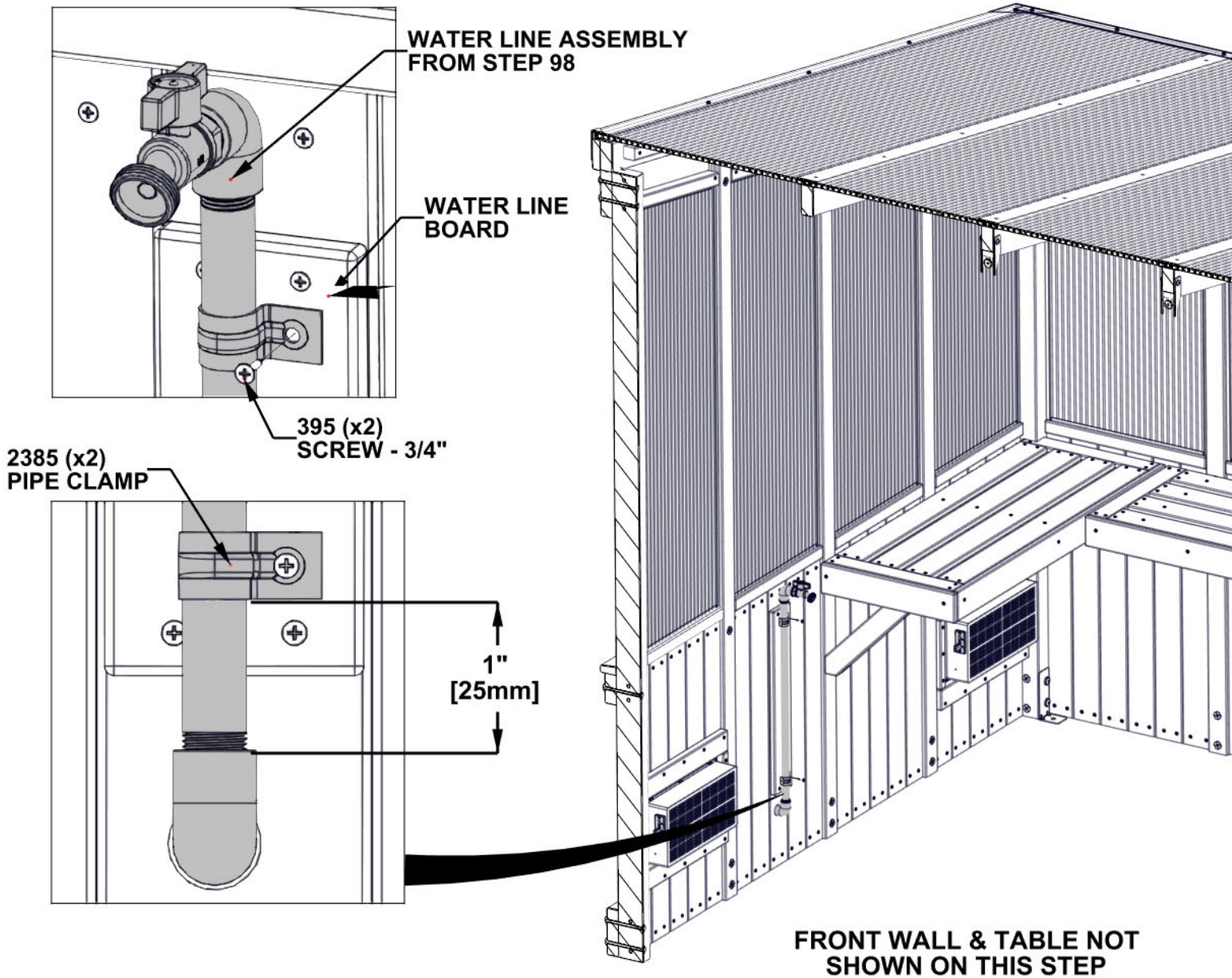

STEP 101 - WATER LINE



A6P00577 RUBBER GROMMET (x1)

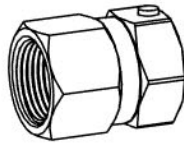

A6P00648 THREADED HOSE FITTING (x1)



A6000809 PLUMBERS TAPE

- NOTES:**
- PUSH RUBBER GROMMET IN HOLE AROUND THE WATER LINE ASSEMBLY.
 - USE PLUMBERS TAPE AND WRAP THREADS OF MALE FITTINGS.
 - FASTEN THREADED HOSE FITTING.

1ST

577 (x1)
RUBBER GROMMET

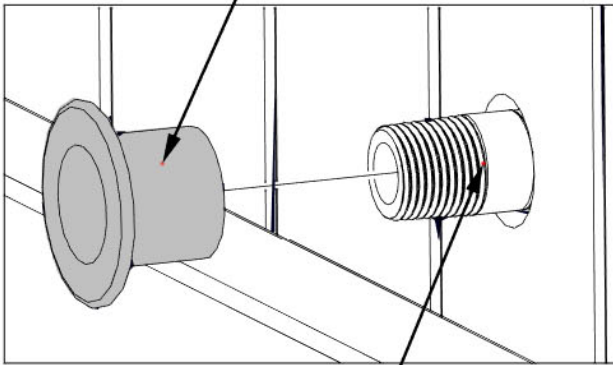

WATER LINE ASSEMBLY FROM STEP 98

2ND

648 (x1)
THREADED HOSE FITTING

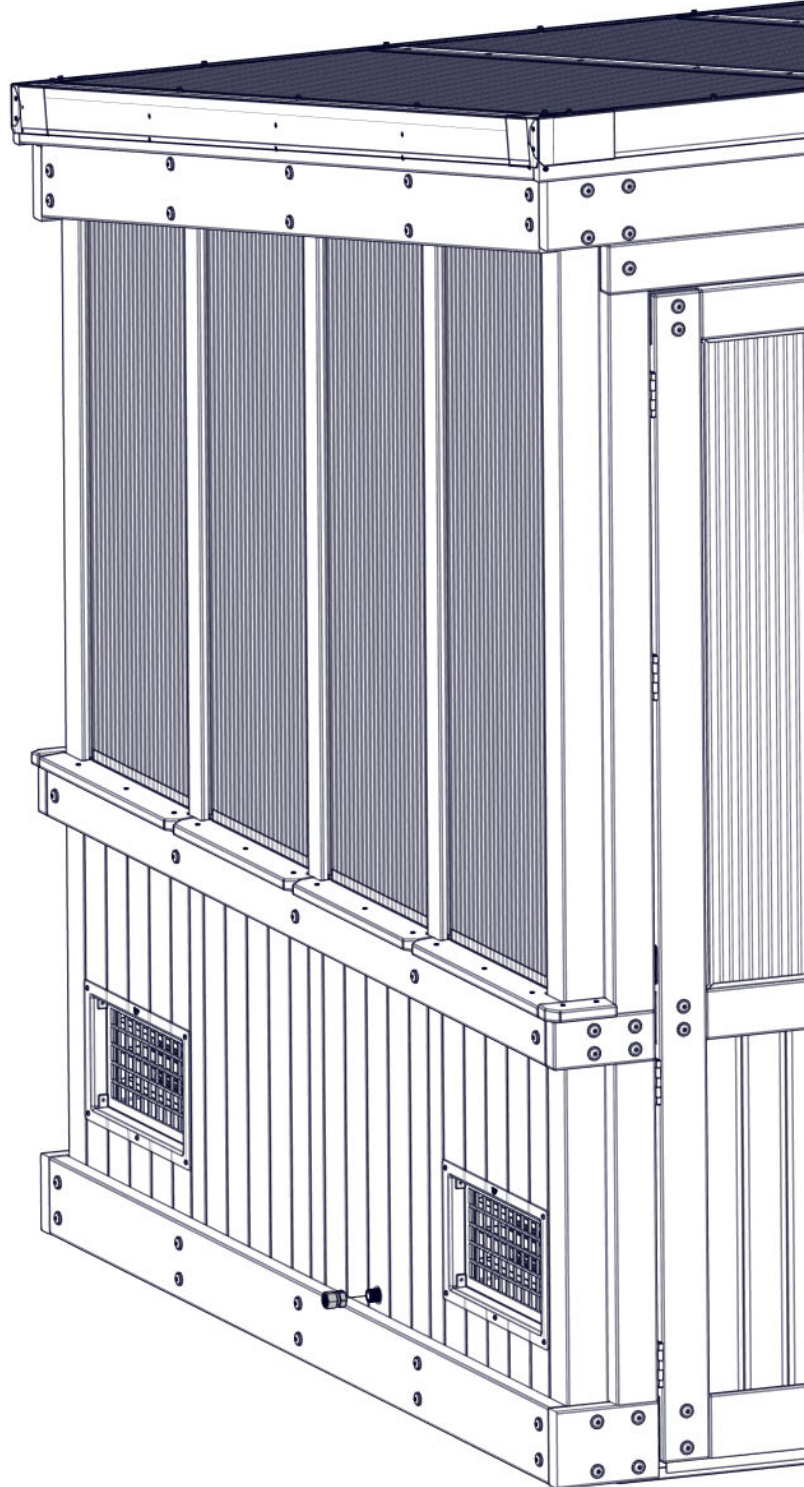
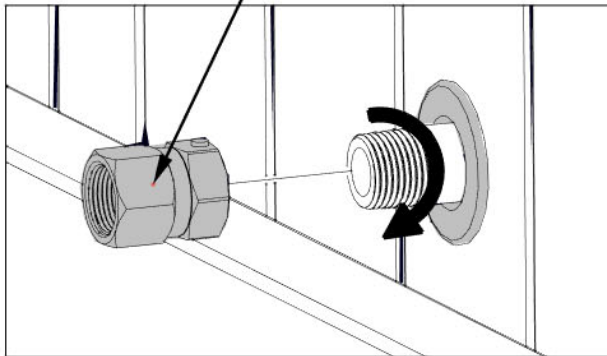

STEP 102 - I.D. TAG

Qty	PART NUMBER	DESCRIPTION
4	H100202	SCREW PWH 8 X 5/8 BLK



A4M02158 BYD ID TAG PATIO
(x1)

- NOTES:**
- CENTER TAG ON DOOR RAIL
 - FASTEN AS SHOWN

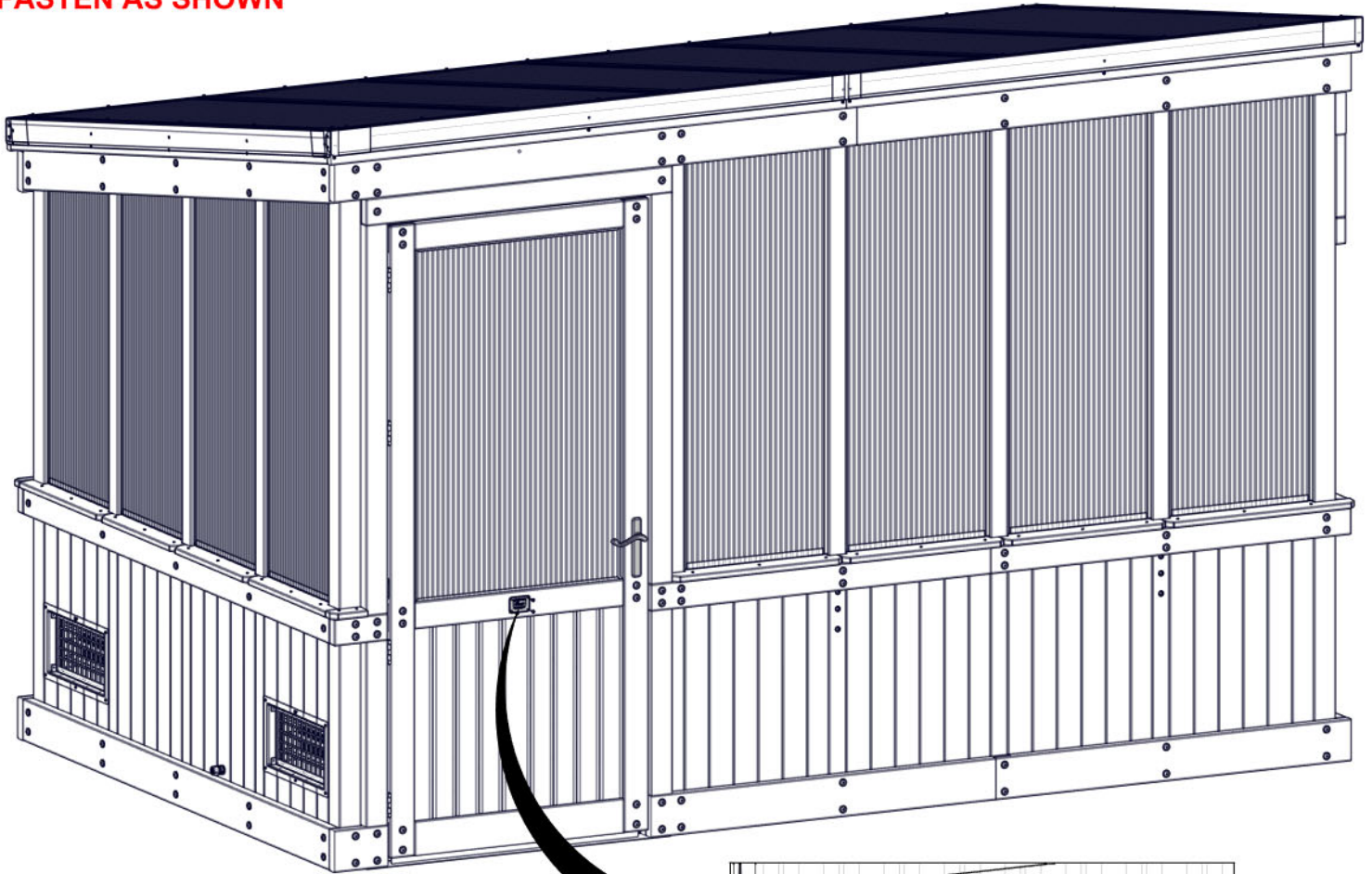

2158 (x1)
BYD ID TAG PATIO

DOOR RAIL

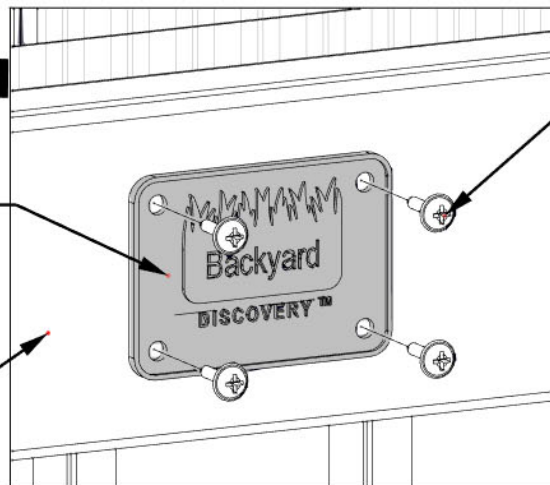

202 (x4)
SCREW - 5/8"

STEP 103 - GROUND STAKES

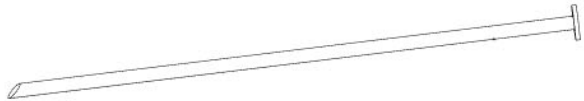

A4M02091 GROUND STAKE REBAR
(x5)

**ONLY USE FOR ANCHORING TO
GROUND. SEE STEP 104 FOR
ANCHORING TO CONCRETE.**

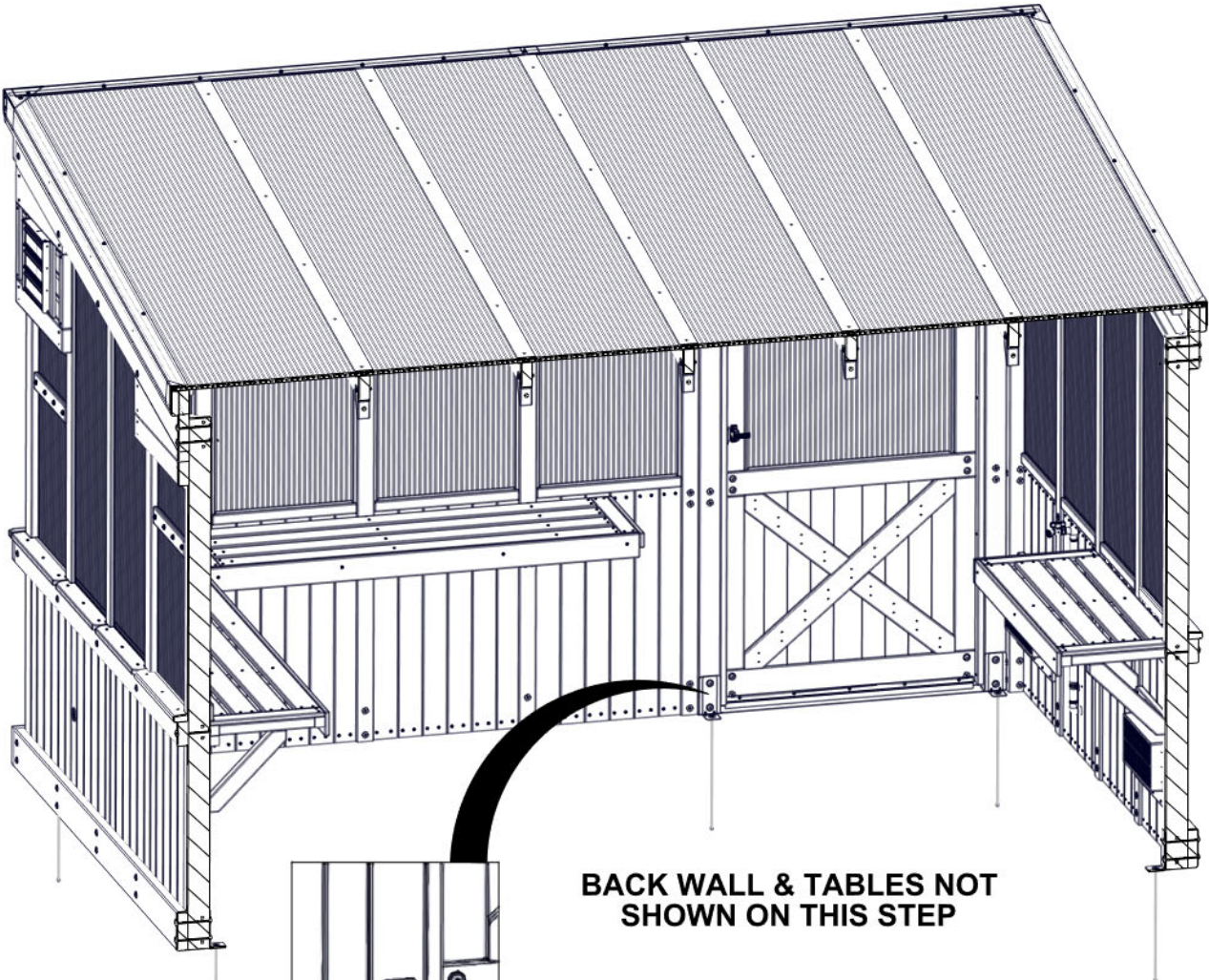

**BACK WALL & TABLES NOT
SHOWN ON THIS STEP**

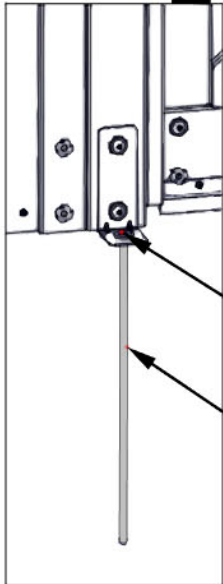

**SLIDE GROUND STAKE
INTO CLIPS (5) LOCATED
AROUND PERIMETER**

**2091 (x5)
GROUND STAKE REBAR**

STEP 104 - CONCRETE ANCHORS

Qty	PART NUMBER	DESCRIPTION
5	H101165	CONCRETE ANCHOR 3/8"x3" BLK

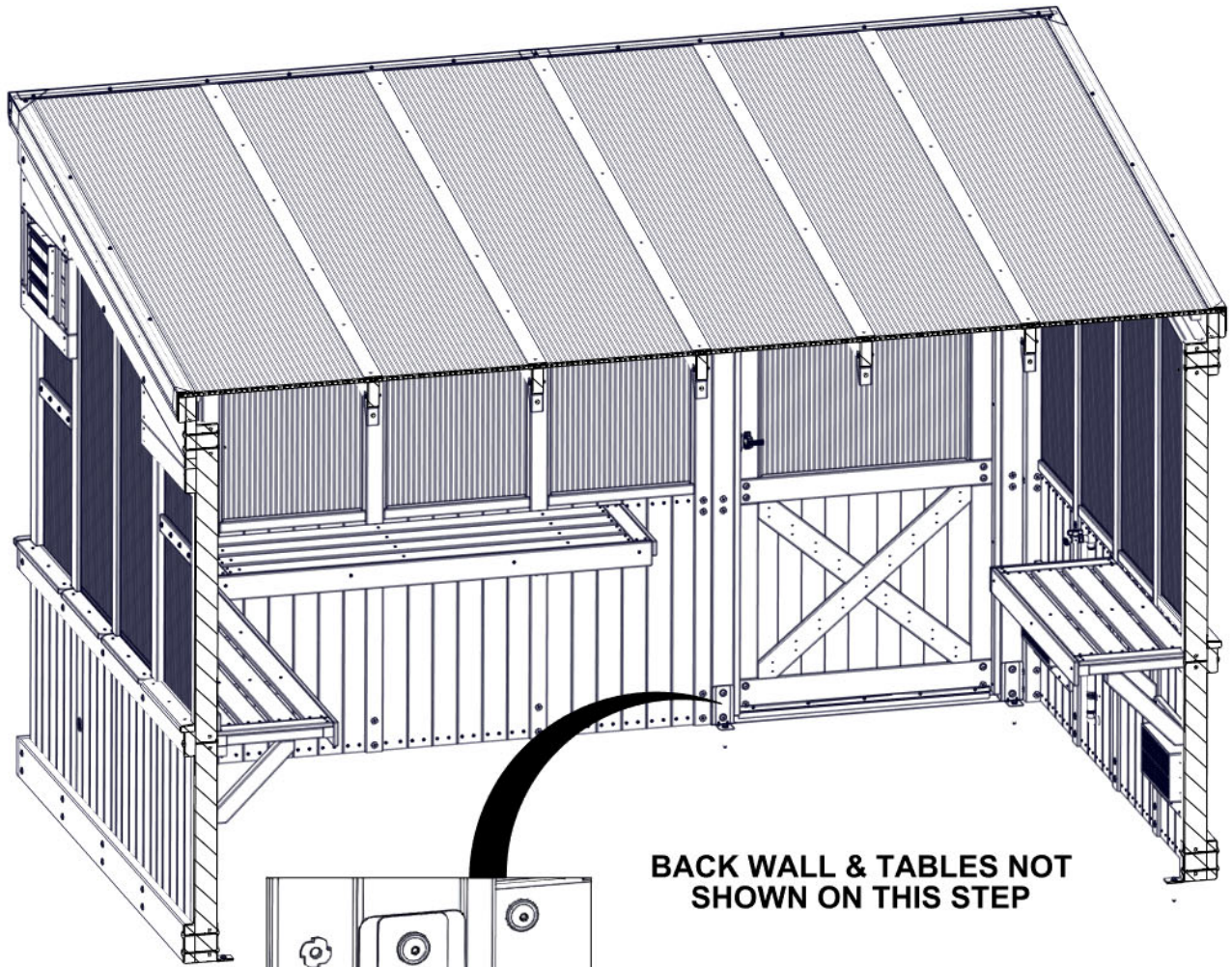

BACK WALL & TABLES NOT SHOWN ON THIS STEP

SLIDE ANCHOR INTO CLIPS (5) LOCATED AROUND PERIMETER

**1165 (x5)
CONCRETE ANCHOR-3"**