

Sit back. Relax. Stay warm.

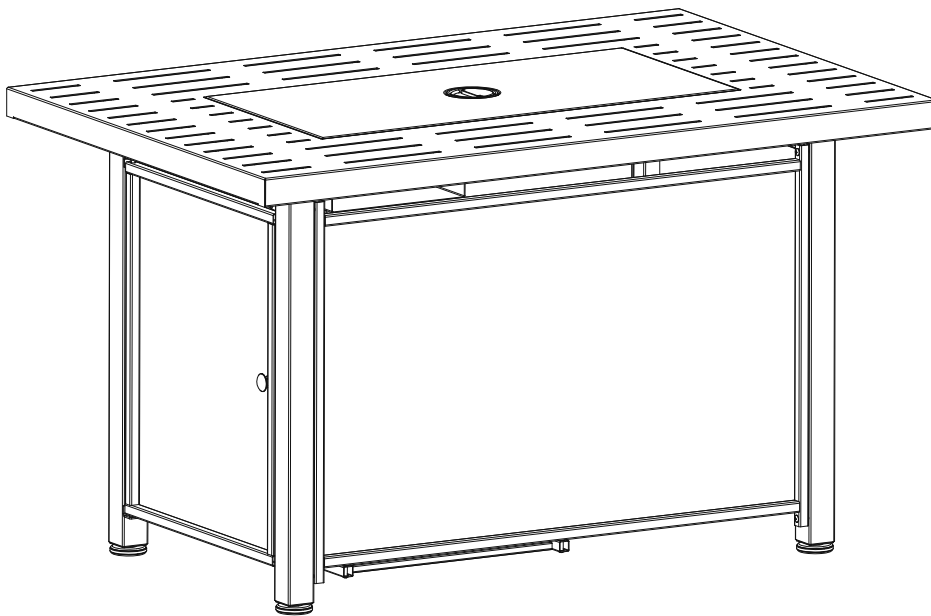

Charlie Aluminum Convertible Fire Table Manual and Instruction Guide



Model #: FP-10314

Item #: KLD4007



WARNING FOR YOUR SAFETY

1. Improper installation, adjustment, alteration, service or maintenance can cause injury or property damage.
2. Read the installation, operation, and maintenance instructions thoroughly before installing or servicing this equipment.
3. Failure to follow these instructions could result in fire or explosion, which could cause property damage, personal injury, or death.



WARNING

For Outdoor Use Only



WARNING

This product can expose you to chemicals including Lead, Chromium (hexavalent compounds), Di(2-ethylhexyl) phthalate (DEHP) and Diisononyl phthalate (DINP), which are known to the State of California to cause cancer and birth defects or other reproductive harm. For more information, go to www.P65Warnings.ca.gov.

Installation Precaution

This fire pit requires a minimum 18 inches of cross-ventilation in all directions.

Failure to provide proper ventilation can void the warranty.



Conforms to ANSI STD Z21.97-2017,
Certified to CSA STD 2.41-2017 Outdoor decorative gas appliances



Electronic Ignition
Requires 1 AA battery
(not included)



ATTACH YOUR RECEIPT HERE

Keep a copy of your proof of purchase or order confirmation which will be needed if you need to contact us about warranty coverage.

Purchase Date: _____



Questions, problems, missing parts?

Before returning to your retailer, contact our exceptional customer service.

Contact us by email at customercare@jrhome.com or call us toll-free at (800) 561-5550, 7:30 a.m. – 4:00 p.m., PST, Monday – Friday .



TABLE OF CONTENTS

Before You Begin	Page 2
Package Contents	Page 3
Safety Information	Page 4
Assembly	Pages 5-10
Operating Instructions	Pages 11-12
Care and Maintenance	Page 13
Troubleshooting	Page 14
Warranty Information	Page 14-15
Converting from Propane to Naturals Gas	Page 16-19



BEFORE YOU BEGIN

Please read and understand this entire manual before attempting to assemble, operate or install this appliance. If you have any questions regarding the product, please contact the retailer.

This manual contains important information about the assembly, operation and maintenance of this LPG fire pit. General safety information is presented in the first few pages and is also located throughout this manual. Keep this manual for future reference and to educate new users of this appliance.

SAFETY INFORMATION

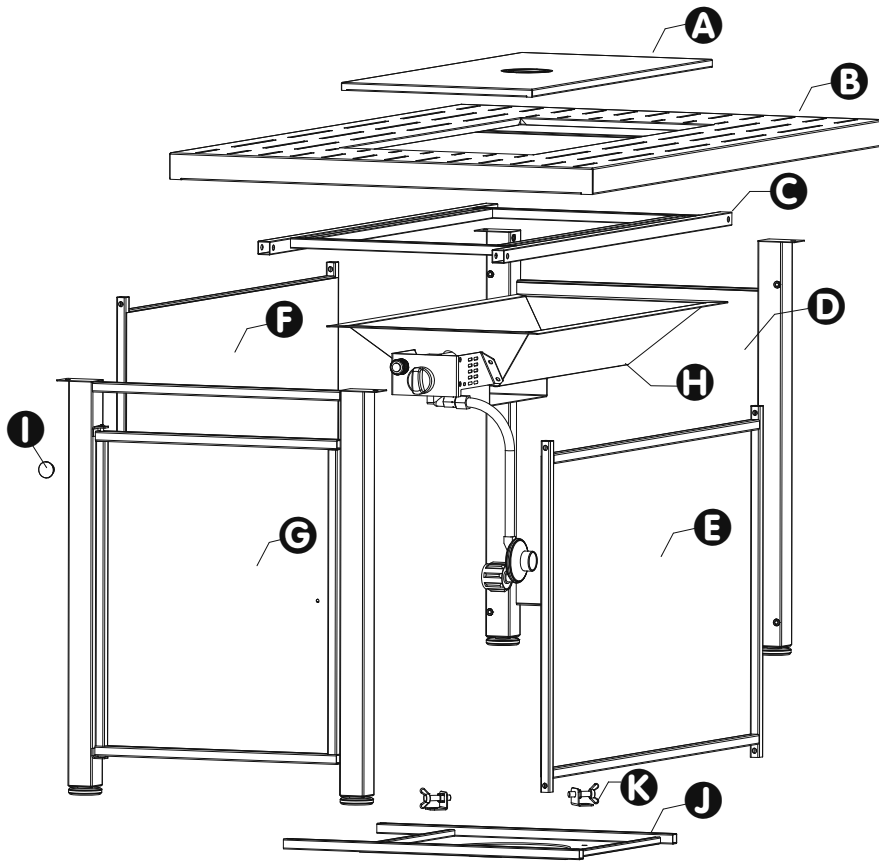

PART	DESCRIPTION	QTY
A	Lid	1
B	Table Top	1
C	Bowl Frame	1
D	Back Panel	1
E	Right Side Panel	1
F	Left Side Panel	1
G	Front Panel	1
H	Burner	1
I	Door Handle	1
J	Bottom	1
K	Cylinder Fixing Plate	2
L	Fire Glass	2

Also required but not included:

Phillips-head screwdriver with medium blade



Electronic ignition.
Requires (1) AA Battery.
(Not Included)



HARDWARE CONTENTS

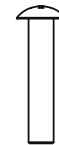

AA

M6x30 screw
Qty: 12

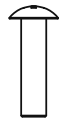

BB

M6x25 screw
Qty: 4



CC

M5x10 screw
Qty: 4



DD

M6x12 Bolt
(Preassembled)
Qty: 2



EE

M6 nut
(Preassembled)
Qty: 2



FF

Wing nut bolt
(Preassembled)
Qty: 2



GG

M4x8 Screw
(Preassembled)
Qty: 1



HH

M4 Washer
(Preassembled)
Qty: 1



SAFETY INFORMATION

This appliance has been tested to and complies with the ANSI Z21.97-2017, Outdoor Decorative Gas Appliances CGA CR 97-003 Outdoor Gas Fireplaces. The installation must conform to local codes or in the absence of local codes to the National Fuel Gas Code, ANSI Z223.1. This manual contains important information about the assembly, operation and maintenance of this fire pit. General safety information is presented in these first few pages and is also located throughout the manual. Keep this manual for future reference and to educate new users of this product. This manual should be read in conjunction with the labeling on the product. Safety precautions are essential when any mechanical or propane fueled equipment is involved. These precautions are necessary when using, storing, and servicing. Using the equipment with the respect and caution demanded will reduce the possibilities of personal injury or property damage. The following symbols (shown below) are used extensively throughout this manual. Always heed these precautions, as they are essential when using any mechanical or propane fueled equipment.

WARNING

Failure to comply with the precautions and instructions provided with this fire pit can result in death, serious bodily injury and property loss or damage from hazards of fire, explosion, burn, asphyxiation, and/or carbon monoxide poisoning. Only persons who can understand and follow the instructions should use or service this fire pit.

WARNING / DANGER

WARNING/DANGER indicates an imminently hazardous situation which, if not avoided, will result in death or serious injury.

WARNING

Do not store or use gasoline or other flammable vapors and liquids in the vicinity of this or any other appliance. An LP-cylinder not connected for use shall not be stored in the vicinity of this or any other appliance.

WARNING

Solid fuels shall not be burned in this appliance.

DANGER

EXPLOSION—FIRE HAZARD

- Keep solid combustibles, such as building materials, paper, or cardboard a safe distance away from the fire pit as recommended by the instructions.
- Provide adequate clearances around air openings into the combustion chamber. Never use the fire pit in spaces which do or may contain volatile or airborne combustibles, or products such as gasoline, solvents, paint thinner, dust particles, or unknown chemicals.
- During operation, this appliance can be a source of ignition. Keep fire pit area clear and free from combustible materials, gasoline, paint thinner, cleaning solvents and other flammable vapors and liquids. Do not use fire pit in areas with high dust content. Minimum fire pit clearances from combustible materials: 2 feet (24 inches) from the sides & 2 feet (24 inches) from the rear, 6 feet (72 inches) from ceiling.
- Never store propane near high heat, open flames, pilot lights, direct sunlight, other ignition sources or where temperatures exceed 120 degrees F (49 degrees C).
- Propane vapors are heavier than air and can accumulate in low places. If you smell gas, leave the area immediately.
- Never install or remove a propane cylinder while the fire pit is lighted, or near flame, pilot lights, or other ignition sources or while fire pit is hot to the touch.
- This fire pit is red hot during use and can ignite flammables too close to the burner. Keep flammables at least 6 feet (72 inches) from top and 2 feet (24 inches) from sides. Keep gasoline and other flammable liquids and vapors well away from fire pit.
- Store the propane cylinder outdoors in a well ventilated space out of the reach of children. Never store the propane cylinder in an enclosed area (house, garage, etc.). If fire pit is to be stored indoors, disconnect the propane cylinder for outdoor storage.

WARNING

- This fire pit is fueled by propane gas. Propane gas is invisible, odorless, and flammable. An odorant is normally added to help detect leaks and can be described as having a "rotten egg" smell. The odorant can fade over time so leaking gas is not always detectable by smell alone.
- Propane gas is heavier than air and leaking propane will sink to the lowest level possible. It can ignite by ignition sources including matches, lighters, sparks, or open flames of any kind many feet away from the original leak. Use only propane gas set up for vapor withdrawal.
- Store or use propane gas in compliance with local ordinances and codes or with ANSI/NFPA 58. Turn off propane when not in use.

DANGER

FOR YOUR SAFETY

If you smell gas:

1. Shut off gas to the appliance.
2. Extinguish any open flame
3. If odor continues, keep away from the appliance and immediately call your gas supplier or fire department.

WARNING

We cannot foresee every use which may be made of our fire pit. Check with your local fire safety authority if you have questions about fire pit use. Other standards govern the use of fuel gases and heat producing products for specific uses. Your local authorities can advise you about these. If no local codes exist, follow National Fuel Gas Code, ANSI Z223.1. In Canada, installation must conform to local codes. If no local codes exist, follow the current National standards of CANADA CAN/CGA-B 149.2.

WARNING: FOR OUTDOOR USE ONLY

CARBON MONOXIDE HAZARD

- This fire pit is a combustion appliance. All combustion appliances produce carbon monoxide (CO) during the combustion process. This product is designed to produce extremely minute, non-hazardous amounts of CO if used and maintained in accordance with all warnings and instructions. Do not block air flow into or out of the fire pit.
- Carbon Monoxide (CO) poisoning produces flu-like symptoms, watery eyes, headaches, dizziness, fatigue and possibly death. You can't see it and you can't smell it. It's an invisible killer. If these symptoms are present during operation of this product get fresh air immediately!
- For outdoor use only. Using this fire pit in an enclosed space can kill you. Never use this fire pit in an enclosed space such as a camper, tent, home, or other unventilated or enclosed area. 
- This fire pit consumes air (oxygen). Do not use in unventilated or enclosed areas to avoid endangering your life.

WARNING

Improper installation, adjustment, alteration, service or maintenance can cause property damage, injury or death. Read the installation, operation and maintenance instructions thoroughly before installing or servicing this equipment.



PREPARATION

Before beginning assembly, be sure to empty contents of carton and make sure all parts are present. If any parts are missing, please contact Customer Service at customer care@jrhome.com or (800)-561-5550, Monday-Friday, 7:30 a.m. – 4:00 p.m. PST.

Place all parts on a soft, level surface for assembly.

Estimated Assembly Time: 60 Minutes | DO NOT over tighten hardware!

- 1 Locate 4 panels **D/E/F/G**.
 Note: Side panel **E** and **F** bottom hole towards to Front panel **G**
 Attach using 8pcs M6x12 Screws (AA).

Hardware: **AA** M6x30 screw x 8

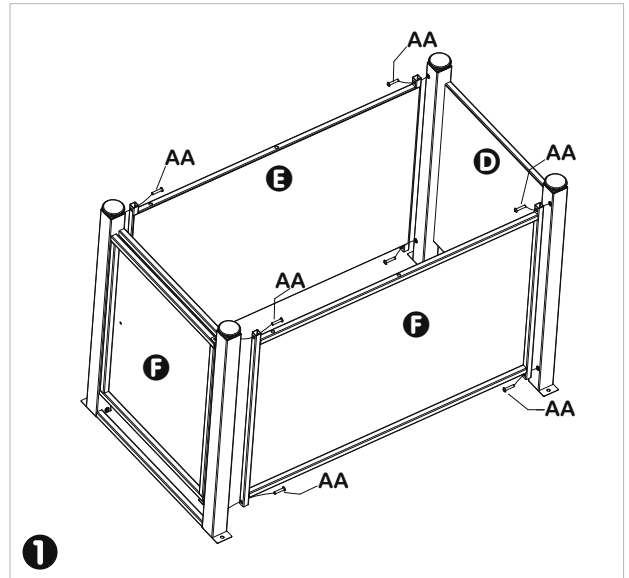
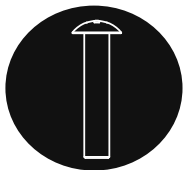

- 2 Attach the 2pcs Cylinder fixing plate **K** to the Bottom **J** with the preassembled M6x12 Bolts (DD) and M6 Nuts (EE)
 Attach the bottom to the side panel **E/F** with 4pcs M6x25 screws (BB).

Hardware: **BB** M6x25 screw x 4

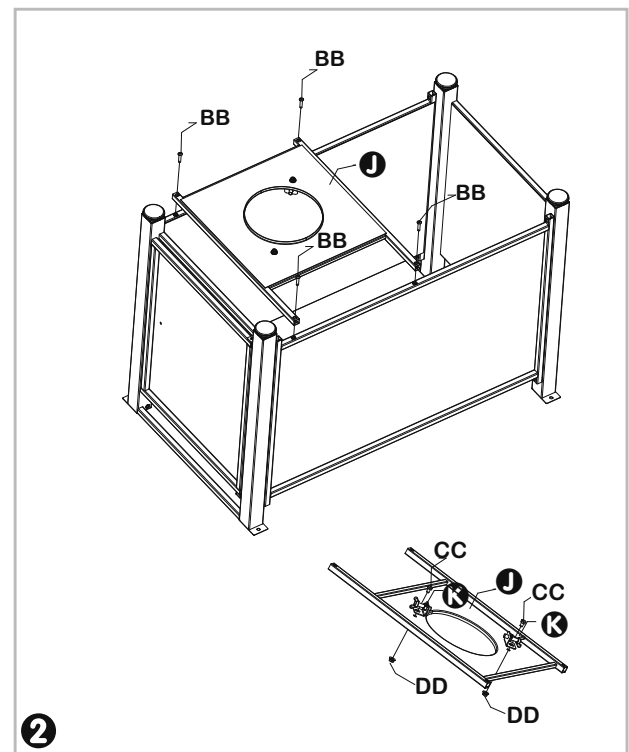

3 Carefully turn the side panel assembly upside down. Attach the Bowl Frame **C** to Front/Back Panel **D**/**E** with 4pcs M6x30 screws (AA).

NOTE: To insure proper bowl frame **C** orientation, locate the Label "C". Make sure the "C" label side faces towards the inside of the table.

Hardware: **AA** M6x30 screw x 4

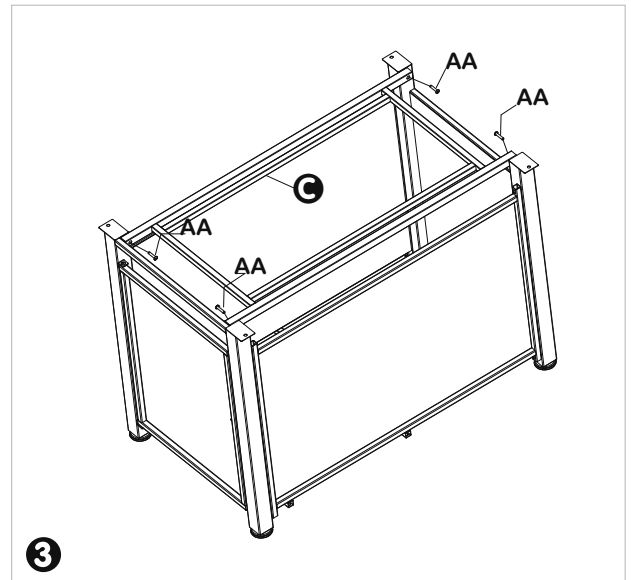
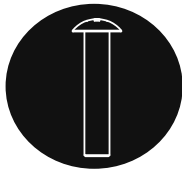

4 Gently place the Burner H into the hole in the Bowl Frame **C**. Make sure the Control Panel on the Burner faces the Front Panel **E**.

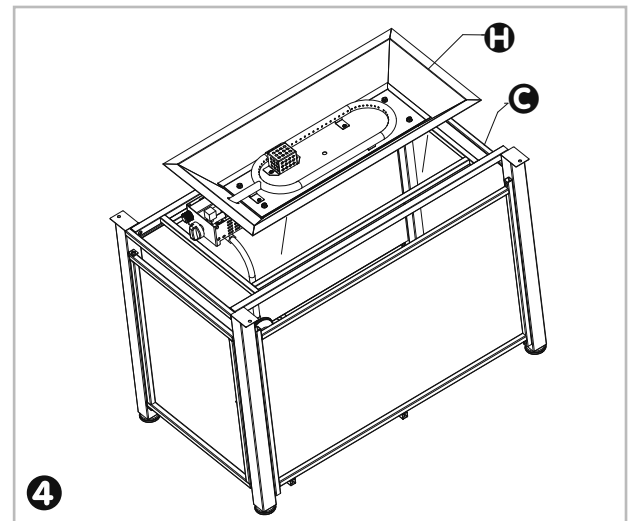

5 Place the Table Top **B** over the legs and align the holes on table top with holes on the top of legs. Fix them with 4pcs M5x10 screws **CC**.

Hardware: **CC** M5x10 screw x 4

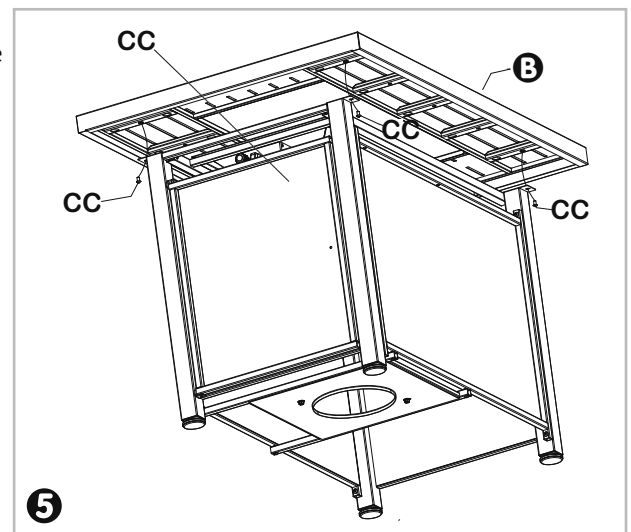

6 Attach the Door Handle **1** to the Front panel **ⓐ** with preassembled M4x8 screw (GG) and M4 Washer (HH).

Hardware: **GG** M4x8 Screw (Preassembled) x 1
HH M4 Washer (Preassembled) x 1



GG



HH

7 Pour the fire glass around the burner. Be careful not to obstruct pilot lighting housing. Put the Lid **A** on the burner.

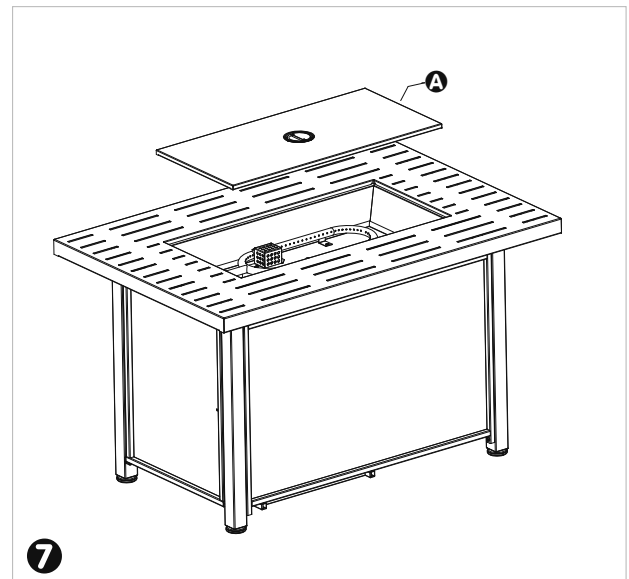
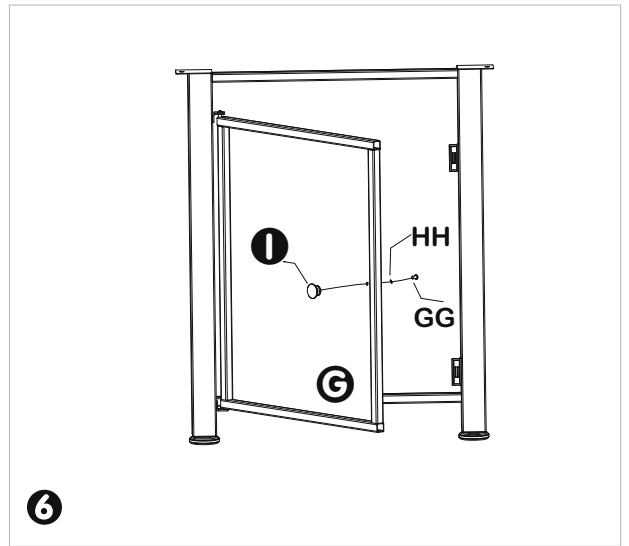

8

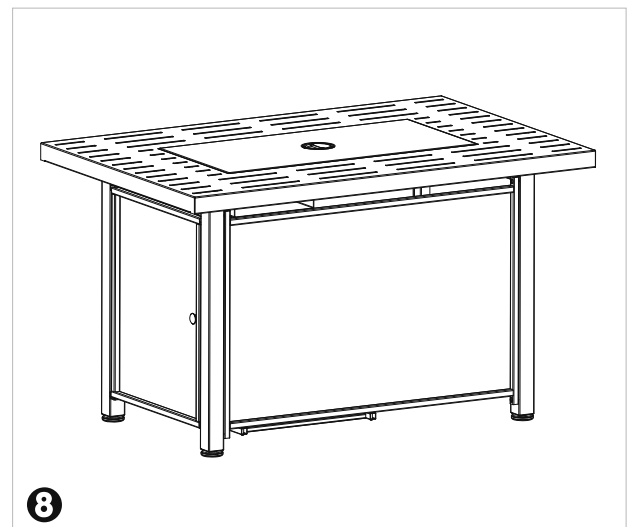



9 Open the Door to access the controls. Unscrew the rubber cap of the electronic igniter. Insert a AA battery with the positive end facing out, then replace the rubber cap.

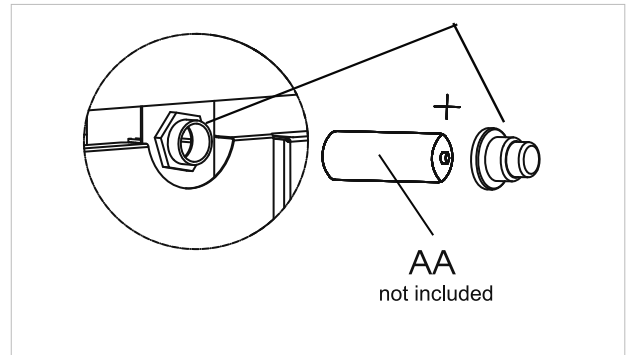

10 Connect hose and regulator to cylinder. The propane gas and cylinder are sold separately. Use a standard 20lb propane cylinder only. Use this fire pit only with a propane vapor withdrawal supply system. See chapter 5 of the standard storage and handling of liquefied petroleum gas, ANSI/NFPA 58. Your local library or fire department should have this book.

Storage of an appliance indoors is permissible only if the cylinder is disconnected and removed from the appliance. A cylinder must be stored outdoors in a well-ventilated area out of the reach of children. A disconnected cylinder must have dust caps tightly installed and must not be stored in a building, garage or any other enclosed area. The maximum inlet gas supply pressure: 250 PSI, the minimum inlet gas supply pressure: 5 PSI.

The minimum hourly of 10,000 BTU is required input rating for a fire pit for automatic operation at ratings less than full input rating. The pressure regulator and hose assembly supplied with the appliance must be used.

The installation must conform with local codes, or in the absence of local codes, with national fuel gas code, ANSI Z223.1/NFPA54, natural gas and propane Installation Code, CSA B 149.1, or propane storage and handling code, B149.2.

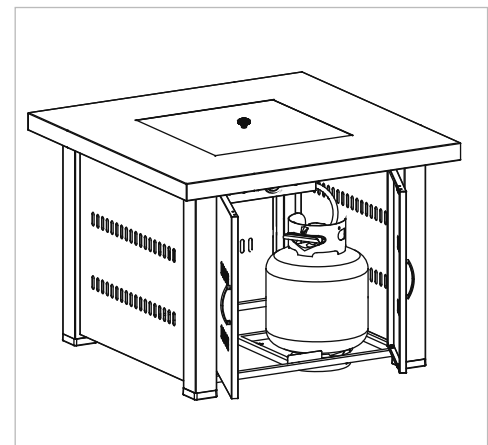
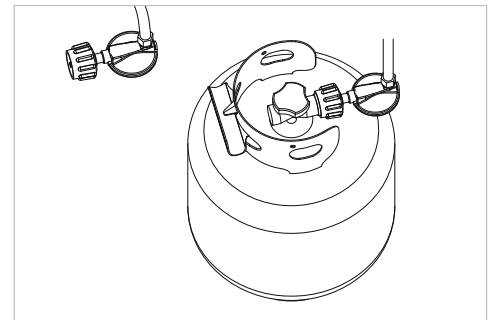
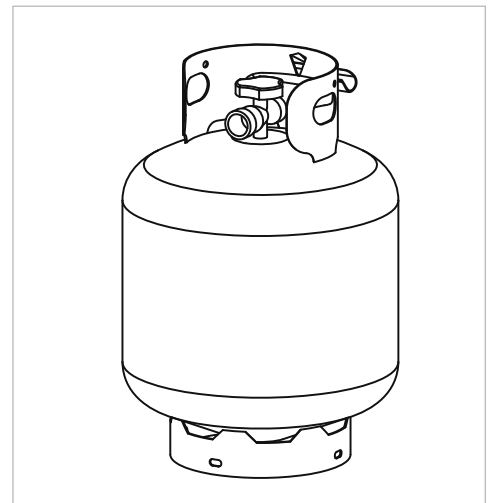



A dented, rusted or damaged propane cylinder may be hazardous and should be checked by your cylinder supplier. Never use a propane cylinder with a damaged valve connection.

The propane cylinder must be constructed and marked in accordance with the specifications for LP gas cylinders of the U.S. Department of Transportation (DOT) or the standard for cylinders, spheres and tubes for transportation of dangerous goods and commission, CAN/CSA-B339.

The cylinder must have a listed overfilling prevention device.

The cylinder used must include a collar to protect the cylinder valve.

Never connect an unregulated propane cylinder to the fire pit.

Attach regulator to cylinder. Complete attachment. Install cylinder.

- Do not store a spare LP gas cylinder under or near this appliance;
- Never fill the cylinder beyond 80 percent full;
- Place the dust cap on the cylinder valve outlet whenever the cylinder is not in use. Only install the type of dust cap on the cylinder valve that is provided with the cylinder valve. Other type of caps or plugs may result in leakage of propane.

ATTENTION: THIS PRODUCT IS NOT FOR COMMERCIAL USE. IT IS INTENDED FOR RESIDENTIAL USE ONLY.

- **Do not sit or stand on this table.**
- **Keep children away during assembly. This item contains small parts which can be swallowed by children.**
- **Do not use indoors or inside any enclosure.**
- **Retain the assembly instructions for future reference.**
- **Installer — please leave these instructions with the owner.**

LEAK CHECK

WARNING!

- Perform all leak tests outdoors.
- Extinguish all open flames.
- NEVER leak test when smoking.
- Do not use the fire pit until all connections have been leak tested and do not leak.

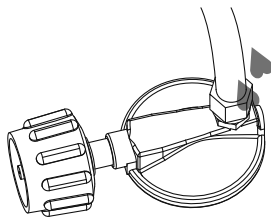

Hose / Regulator
Connection

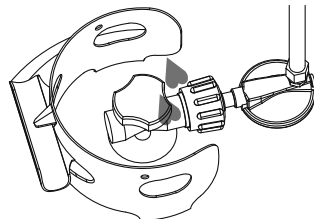

Regulator / Cylinder
Connection

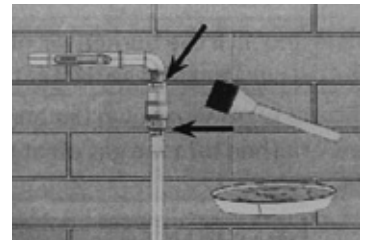
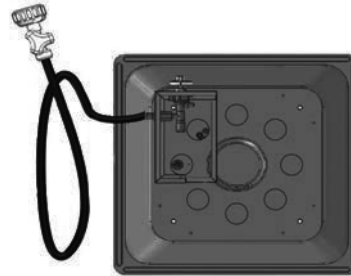

1. Make 2-3 oz. of leak test solution (one part liquid dishwashing detergent and three parts water).
2. Apply several drops of solution where hose attaches to regulator.
3. Apply several drops of solution where regulator connects to cylinder.
4. Make sure all valves are turned OFF.
5. Turn cylinder valve ON.

If bubbles appear at any connection there is a leak.

1. Turn cylinder valve OFF.
2. If leak is at hose/regulator connection: tighten connection and perform another leak test. If bubbles continue appearing, the hose should be returned to the place of purchase.
3. If leak is at regulatory/cylinder valve connection: disconnect, reconnect, and perform another leak test. If you continue to see bubbles after several attempts, cylinder valve is defective and should be returned to cylinder's place of purchase.

If NO bubbles appear at any connection, the connections are secure.

NOTE: Whenever gas connections are loosened or removed, you must perform a complete leak test. Complete installation.



CAUTION

Do not attempt to operate until you have read and understand all General Safety Information in this manual, all assembly is complete, and leak test has been performed.

DANGER!

FOR OUTDOOR USE ONLY



CARBON MONOXIDE HAZARD

Never use this inside a house or other unventilated or enclosed areas. This fire pit consumes air (oxygen). Do not use in unventilated or enclosed areas to avoid endangering your life.

WARNING

Very hot while in operation!

Never lean over the fire pit while in use. Do not touch Table Top or burner Assembly while the fire pit is in operation. Fire pit will be hot after use. Handle with care. Wait until fire pit has cooled down after use before placing lid on Table Top or touching any surfaces. Failure to follow these instructions may result in serious bodily injury.

WARNING

FOR YOUR SAFETY

Be careful when attempting to manually ignite this fire pit. Holding in the control knob for more than 10 seconds before igniting the gas will cause a ball of flame upon ignition.



OPERATION CHECKLIST:

For a safe and pleasant heating experience, review this checklist before each use:

- I am familiar with entire owner's manual and understand all precautions noted.
- All components are properly assembled, intact, and operable.
- No alterations have been made.
- All gas connections are secure and do not leak.
- Wind velocity is below 10mph.
- I understand the unit will operate at reduced efficiency below 40°F.
- I understand the fire pit is for outdoor use (outside any enclosure).
- There is adequate fresh air ventilation.
- Fire pit is away from gasoline and other flammable liquids or vapors.
- Fire pit is away from windows, air intake openings, sprinklers, and other water sources.
- Fire pit is at least two (2) feet on all sides/front/back and six (6) feet overhead from combustible materials.
- Fire pit is on a hard and level surface.
- There are no signs of spider/insect nests in fire pit orifices.
- All burner passages and air circulation passages are clear.
- I understand children and adults should be alerted to the hazard of high surface temperatures and should stay away to avoid burns or clothing ignition.
- I understand young children should be carefully supervised when they are in the area of the fire pit.
- I understand clothing or other fabric material should not be hung from the fire pit or placed on or near the fire pit.
- I understand that any guard or other protective device removed for servicing the fire pit must be replaced prior to operating the fire pit.
- I understand installation and repair should be done by a qualified service person, and that the fire pit should be inspected before each use and at least annually by a qualified service person.
- I understand that more frequent cleaning may be required as necessary and that it is imperative that the control compartment, burner, and circulating air passageways of the fire pit be kept clean.
- The fire pit is constructed of aluminum, a relatively soft/flexible metal, and I should not allow anyone to sit or lean heavily on the top of the fire pit, which can cause bending or warping.



BEFORE TURNING GAS SUPPLY ON:

1. Your fire pit was designed and approved for outdoor use only. Do NOT use it inside a building, garage, or any other enclosed area.
2. Make sure surrounding areas are free of combustible materials, gasoline, and other flammable vapors or liquids.
3. Ensure that there is no obstruction to air ventilation. Be sure all gas connections are tight and there are no leaks.
4. Be sure the cylinder is clear of debris. Be sure any component removed during assembly or servicing is replaced and fastened prior to starting.

OPERATING INSTRUCTIONS



NOTE: This model has an Electronic Igniter and requires one AA battery. Unscrew IGNITER BUTTON to install. Refer to Step 9.



Electronic igniter requires AA battery

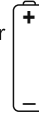

! DANGER!

FOR OUTDOOR USE ONLY



CARBON MONOXIDE HAZARD

Never use this fire pit inside a house or other unventilated or enclosed areas. This fire pit consumes air (oxygen). Do not use in unventilated or enclosed areas to avoid endangering your life.



BEFORE LIGHTING:

1. Smell all around the unit area for gas. Be sure to smell near the bottom as gas is heavier than air and will settle to the lowest point. If you smell gas, shut off the gas to the appliance, extinguish any open flame, and if the odour persists, call your gas supplier or the fire department.
2. The fire pit should be thoroughly inspected before each use and by a qualified service person at least annually. If relighting a hot fire pit always wait at least five minutes.
3. Inspect hose assembly for evidence of excessive abrasion, cuts or wear. Suspect areas should be leak tested. If the hose leaks, it must be replaced prior to operation. Only use the replacement hose assembly specified by the manufacturer.

WHEN FIRE PIT IS ON:

Burner will display tongues of blue and yellow flame. These flames should not produce thick black smoke, indicating an obstruction of airflow through the burners. If excessive flame is detected, turn off fire pit and consult the **Troubleshooting** section of this manual.



LIGHTING:

NOTE: Use only your hand to depress or turn the gas control knob. Never use tools. If the knob will not depress or turn by hand, DO NOT try to repair it. Call a qualified professional service technician. Force or attempted repair may result in fire or explosion and will void the warranty.

1. Turn the control knob to "OFF" position (Fig. A).
2. Fully open LP cylinder valve. **Note: For initial start or after any cylinder change, hold Control Knob IN for 2 minutes to purge air from gas lines before proceeding.**
3. Depress and turn the control knob counterclockwise to HIGH – counterclockwise 90° (Fig. B). Continue to depress the control knob for 3-5 seconds.
4. While holding control knob in, push the Electronic Ignition button to ignite the main burner. (The ignition will produce a soft snapping/crackling sound. If the fire pit does not light and there is no snapping sound, replace the battery.)
5. After fire pit lights, wait 10 seconds, then release control knob.
6. Observe the flame height when lit. Flame should reach between 3 and 13 inches in height. Overly short or tall flame can indicate a problem.
7. To decrease the flame, turn the control knob clockwise to LOW (Fig. C). To increase the flame, turn the control knob counterclockwise to HIGH (Fig. B).

NOTE: If burner fails to remain lit, close all valves and wait at least 5 minutes before attempting to light.

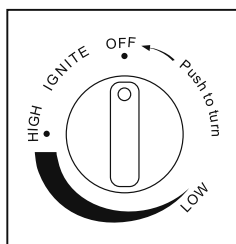
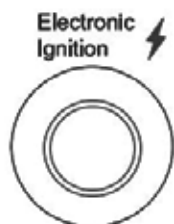

Figure A

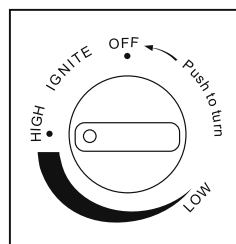

Figure B

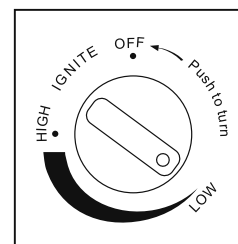
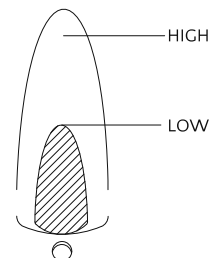

Figure C



SHUT DOWN:

1. To extinguish burner depress control knob and turn it clockwise to OFF.
2. Turn cylinder valve clockwise to OFF and disconnect regulator when fire pit is not in use.



AFTER-OPERATION CHECKLIST:

1. Gas control knob is in OFF position.
2. Gas tank valve is OFF.
3. Gas line is disconnected.



To enjoy years of outstanding performance from your fire pit, make sure you perform the following maintenance activities on a regular basis:

1. Use warm soapy water for cleaning. Never use flammable or corrosive cleaning agents.
2. While cleaning your unit, be sure to keep the area around the burner and control compartment dry at all times. Do not submerge the control valve assembly. If the gas control is submerged in water, do NOT use it. It must be replaced. Make sure fire pit has cooled completely before cleaning or covering with a cover.
 - A. Keep the appliance area clear and free from combustible materials, gasoline and other flammable vapors and liquids.
 - B. Do not obstruct the flow of combustion and ventilation air.
 - C. Keep the ventilation opening(s) of the cylinder enclosure free and clear from debris.
3. Air flow must be unobstructed. Keep controls, burner, and circulating air passageways clean. Signs of possible blockage include:
 - Gas odor with extreme yellow tipping of flame.
 - Fire pit does NOT reach the desired temperature.
 - Fire pit glow is excessively uneven.
 - Fire pit makes popping noise.
 - Spiders and insects can nest in burner or orifices. This dangerous condition can damage fire pit and render it unsafe for use. Clean burner holes by using a heavy-duty pipe cleaner. Compressed air may help clear away smaller particles.
 - Carbon deposits may create a fire hazard. Clean burner screen with warm soapy water if any carbon deposits develop.



Note: In a salt-air environment (such as near an ocean), corrosion occurs more quickly than normal. Frequently check for corroded areas and repair them promptly.

SERVICE:

Only a qualified service person should repair gas passages and associated components.



WARNING

FOR YOUR SAFETY

- Do NOT touch or move fire pit for at least 45 minutes after use.
- Burner is hot to the touch.
- Allow burner to cool before touching.

STORAGE:

Between uses:

- Turn control knob OFF.
- Disconnect LP source.
- Store fire pit in an area sheltered from direct contact with inclement weather (such as rain, sleet, hail, snow, dust and debris).
- If desired, cover fire pit to protect exterior surfaces and to help prevent build-up in air passages.

During periods of extended

inactivity or when transporting:

- Turn control knob OFF.
- Disconnect LP source and move to a secure, well-ventilated location outdoors.
- Store fire pit in an area sheltered from direct contact with inclement weather (such as rain, sleet, hail, snow dust and debris).
- If desired, cover fire pit to protect exterior surfaces and to help prevent build-up in air passages. Never leave LP cylinder exposed to direct sunlight or excessive heat.

Note: Wait until fire pit is cool before covering.

Caution: Always allow fire pit to cool before attempting service.

TROUBLESHOOTING



PROBLEM	POSSIBLE CAUSE	CORRECTIVE ACTION
Burner will not light	Propane cylinder is frosted over	Wait until the propane cylinder warms up and becomes unfrosted
	Blockage in orifice	Clear blockage
	Control knob is not in ON position	Turn control knob to ON
Burner flame is low	Gas pressure is low	Turn cylinder valve OFF and replace cylinder
	Outdoor temperature is less than 40°F and tank is less than 1/4 full	Use a full cylinder
	Control knob fully ON	Check burner and orifices for blockage
Carbon build-up Thick Black Smoke	Dirt or film on burner screen	Clean burner screen
	Blockage in burner	Remove blockage and clean burner screen inside and outside.

WARRANTY AND REVIEWS



Extend Your Warranty By Leaving A Review

We want your opinion about your purchase...and we want you to tell everyone about it!

Just leave a review for the product on the retailers website where you made your purchase, or at www.jrhome.com, and fill in the online warranty at www.jrhome.com/warranty-registration within 30 days of purchase to receive a complimentary extra year of warranty protection.

Follow us on:



#jrhome #paramount

IMPORTANT

For questions, concerns or problems with our product please email our customer service department:

customercare@jrhome.com

DATED PROOF OF PURCHASE REQUIRED FOR WARRANTY SERVICE

Si vous éprouvez des difficultés ou si vous avez des questions ou des préoccupations, prière de faire parvenir un courriel à notre service à la clientèle

customercare@jrhome.com

UNE PREUVE D'ACHAT DATÉE EST REQUISE POUR SE PRÉVALOIR DE LA GARANTIE.

WARRANTY

This product is inspected, tested and carefully packaged to minimize the chance of damage during shipment. If a part (excluding light bulbs, glass and fuses*) within one year from the date of purchase proves to be defective in material or fabrication under normal use, the part will be repaired or replaced. The Company's obligation under the warranty is to replace or repair defective parts at our discretion. Any expenses or damage resulting from the installation, removal or transportation of the product will be the responsibility of the owner and are not covered by this warranty. The owner assumes all other risks arising from the use or misuse of the product. The warranty will be void if the product damage or failure is deemed by the Company to be caused by accident, alteration, misuse, abuse, incorrect installation or removal, or connection to an incorrect power source by the owner. The Company neither assumes, nor authorizes any person or entity to assume for it any obligation or liability associated with its products. Light bulbs and fuses are not covered under this warranty. If you have any questions regarding the warranty or service, please contact us at **customercare@jrhome.com**.

Customer Service :

JR Home Products

Unit 306 - 19100 Airport Way, Pitt Meadows, BC V3Y 0E2

Toll Free : 1-800-561-5550

E-mail : **customercare@jrhome.com**

AVERTISSEMENT

Ce produit a été soigneusement inspecté, testé et emballé afin de minimiser les risques de dommages durant le transport. Si l'une des pièces (à l'exception des verres, des ampoules électriques et des fusibles*) s'avère défectueuse au niveau de sa fabrication ou de ses matériaux dans l'année qui suit la date de l'achat suite à une utilisation normale, la pièce sera réparée ou remplacée. La compagnie est tenue de réparer ou remplacer les pièces défectueuses à sa discrétion, en vertu de la garantie. Tous frais ou dommage résultant de l'installation, du démantèlement ou du transport du produit demeurent la responsabilité du client et n'est pas couvert par cette garantie. Le client assume tout autre risque résultant de l'utilisation correcte ou fautive du produit. La garantie devient nulle si la compagnie détermine que le dommage ou le mauvais fonctionnement est causé par un accident, une modification, une mauvaise utilisation, un abus, une mauvaise installation ou un mauvais démantèlement ou un branchement à une source électrique inadéquate de la part du client. La compagnie n'est pas responsable et n'autorise quiconque, personne ou entité légale, à accepter de responsabilité ou obligation en son nom, en rapport avec ses produits. * Les ampoules électriques et les fusibles ne sont pas couverts par cette garantie. Pour toute question au sujet de la garantie ou du service, contacter le service à la clientèle à : **customercare@jrhome.com**.

Service à la clientèle:

JR Home Products

Unit 306 - 19100 Airport Way, Pitt Meadows BC V3Y 0E2 Numéro

sans frais: 1-800-561-5550

Courriel: **customercare@jrhome.com**

You **MUST** register your product within 30 days of purchase to receive warranty service.

Registration can be completed online at **www.jrhome.com** or by mailing this form.

Vous **DEVEZ** enregistrer votre produit dans les 30 jours suivant l'achat pour bénéficier du service de garantie.

L'enregistrement sera complet une fois que vous aurez posté ce formulaire ou que vous serez inscrit en ligne.

Warranty Registration Information Form / Formulaire d'enregistrement de la garantie

Name / Nom : _____

Street / Adresse : _____

City / Ville : _____

Province / Province : _____

Postal Code / Code postal : _____

Daytime Phone # / No téléphone jour : _____

Evening Phone # / No téléphone soir : _____

E-Mail Address / Courriel : _____

Product/Produit : _____

Place of Purchase / Lieu de l'achat : _____

Date of Purchase / Date de l'achat : _____

Model # / No de modèle : _____

Serial # / Numéro de série : _____

You **MUST** register your product to receive warranty service.

For warranty service, contact J&R Home Products at the address, phone numbers listed below within 30 days of purchase. Be sure to have your sales receipt and original date of purchase. All warranty service will be coordinated by J&R Home Products service center.

Vous **DEVEZ** enregistrer votre produit pour vous prévaloir de la garantie.

Afin de faire valoir la garantie, communiquez avec J&R Home Products à l'adresse et aux numéros indiqués ci-dessous dans les 30 jours suivant la date d'achat. Ayez en main votre reçu et la date d'achat. Toutes les demandes liées aux garanties seront traitées par le centre de service de J&R Home Products.





⚠ WARNING
 MAKE SURE ALL CONTROL KNOBS & CYLINDER VALVE ARE IN OFF POSITION BEFORE CONVERTING.

This appliance is portable and shipped from the factory for use with Liquid Propane (LP Gas), which is delivered to the grill from removable tanks (LP tanks and their use are covered elsewhere in this manual). If a Natural Gas connection is available, the user may wish to change the gas delivery system to the more permanent Natural Gas supply.

This appliance is certified for use with either Liquid Propane (LP Gas) or Natural Gas and comes complete with the necessary parts to convert the appliance for use with Natural Gas hose and regulator (sold separately). The conversion valves allows the use of Natural Gas without replacing the burners or entire valve system.

A qualified gas technician is required to do the conversion. Your warranty may be voided if the conversion is improperly completed. Please retain the parts supplied with the appliance and these instructions so the technician can do the conversion.

Orifice Chart

The different burner valves in this appliance have different BTU ratings. The holes in the fittings are orifices themselves drilled to different sizes so as to allow the proper amount of gas to flow through them. Please note the chart below to give an easy reference for the various orifice opening sizes for the different valves in the appliance.

Propane (manifold pressure 11")		NG (manifold pressure 7")	
Orifice Size	Input Rate [BTU/h]	Orifice Size	Input Rate [BTU/h]
2.3mm	55000	3.78mm	55000

NG Hose and Regulator Conversion tools required:

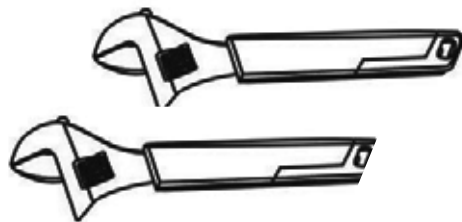

Adjustable Wrench (2)

⚠ WARNING
 Make sure all appliance components are completely cooled and gas supply is turned off and removed from the appliance prior to performing the conversion.

WARNING! To avoid the possibility of burns conversions should only be done when the burner is turned off. Turn gas off at source and disconnect the burner before beginning conversion.

WARNING! This conversion must be performed by a licensed gas fitter and all connections must be leak tested before operating the appliance.

Your burner comes from the factory set up for propane but it can be easily converted to natural gas by following these steps:

1. Disconnect the flex line from the burner using wrench.



2. Remove orifice connector using wrench.

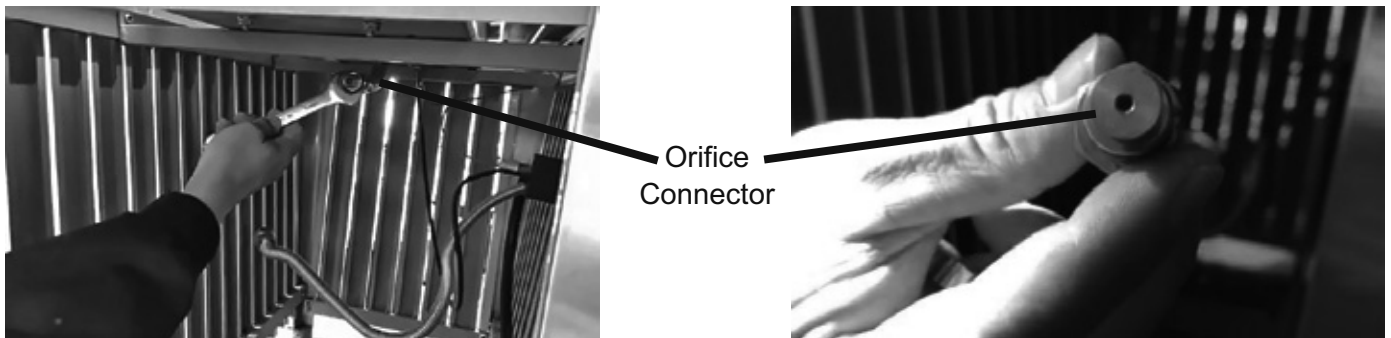

3. Install the natural gas air shutter from the parts bag.

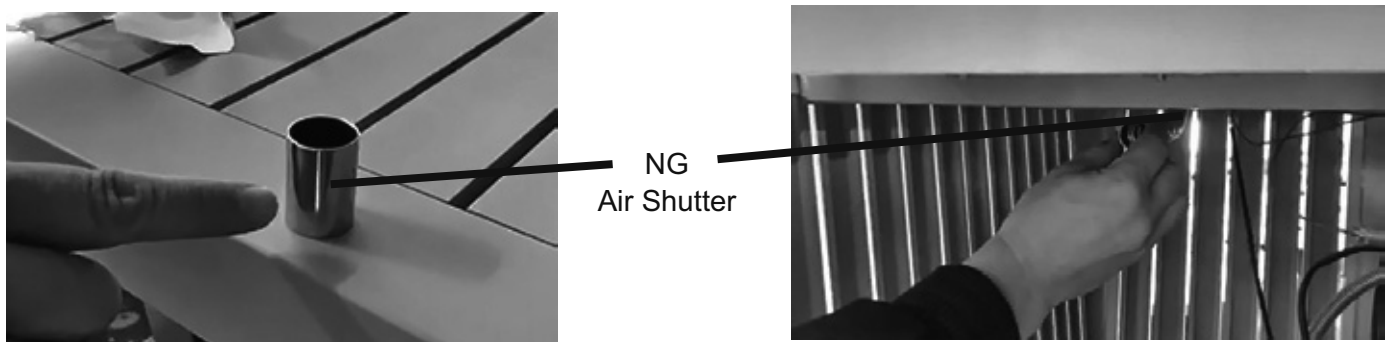

4. Separate the two parts of the orifice connector by using two wrenches.

Orifice Connector



5. Replace the propane orifice with the natural gas orifice and retighten with wrenches.

Natural Gas Orifice



6. Insert the Orifice holder into the air shutter. Re-attach flex hose. Tighten with wrench.

Orifice Connector
in Air Shutter



7. Connect NG hose to the burner control with a wrench. Connect the quick connect adapter to the NG supply valve.



Quick Connect Natural Gas Adapter
(Not Included)

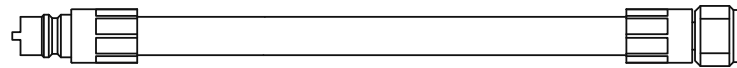

Quick Connect Natural Gas (NG) Hose
(Not Included)

PART# NL-NGHOSE
www.paramountathome.com

8. Connect the NG hose to the Quick Connect adapter.

9. Fill out the conversion label included with your burner and apply it to the inside of the control panel access door.

A leak test must be performed according to the leak testing instructions found in the manual.



Natural Gas Hook-Up

The gas appliance is designed to operate at an inlet pressure of 7 inches water column. The piping up to the appliance is the responsibility of the installer. Connect the inlet valve to rigid pipe, copper tube or an approved flexible metal connector, which complies with Z21.4/CSA 6.10. If using a gas hose(not supplied) connect the flared end of the hose to the connector on the end of the inlet valve. Tighten using two wrenches. (Do not use thread sealer/pipe dope.) Leak test all joints prior to using the appliance. Piping and valves upstream of the quick disconnect are not supplied. The gas supply pipe must be sufficiently sized to supply the BTU/h specified on the rating plate, based on the length of the piping run. The quick disconnect must not be installed in an upward direction and a readily accessible manual shut-off valve must be installed upstream of, and as close to, the quick disconnect as is feasible.

Purge the gas supply line of any trapped air prior to the first firing of the unit.



WARNING!

- The installation must be performed by a licensed gas fitter, and all connection must be leak tested before operating the appliance.
- Ensure all hose connections are tightened using two wrenches. Do not use Teflon tape or pipe dope on any hose connection.
- Ensure the hose does not contact any high temperature surfaces or it may melt and leak causing a fire.
- Locate the hose out of pathways where people may trip over it or in areas where the hose may be subject to accidental damage.
- Leak test all the connections using a soap and water solutions as per the leak testing instructions found in the manual.