

PRO-FORM[®]

HYBRID TRAINER

proformfitness.ca

Model No. PFEL03721C.0

Serial No. _____

Write the serial number in the space above for reference.

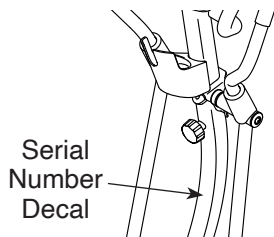

USER'S MANUAL

REGISTER YOUR PRODUCT

To register your product and activate your warranty today, go to iconservice.ca.

MEMBER CARE

Call toll-free 1-888-936-4266
Mon.–Fri. 7:30 a.m.–4:30 p.m. ET
(excluding holidays)

or email us at
customerservice@iconcanada.ca

Please do not contact the store.

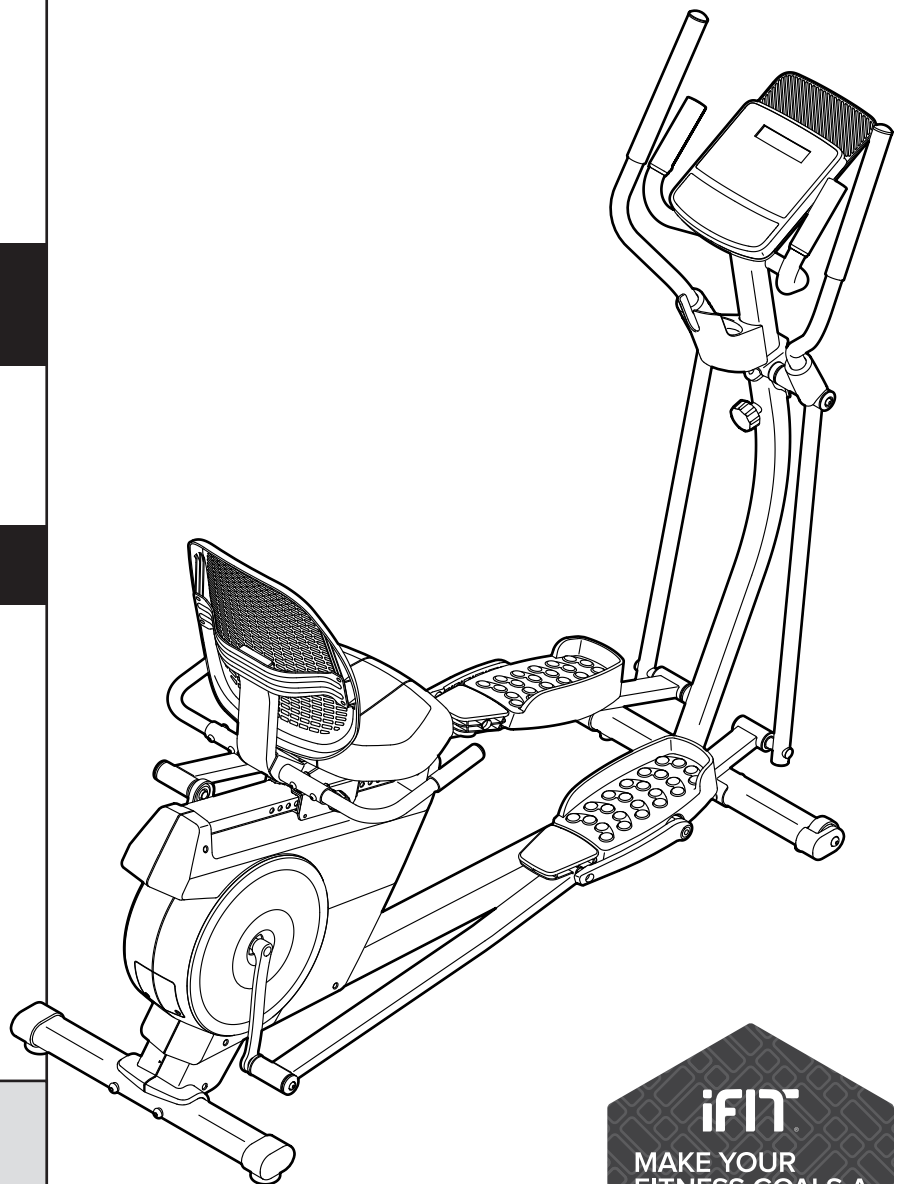

CAUTION

Read all precautions and instructions in this manual before using this equipment. Keep this manual for future reference.



TABLE OF CONTENTS

WARNING DECAL PLACEMENT 2

IMPORTANT PRECAUTIONS 3

BEFORE YOU BEGIN 5

PART IDENTIFICATION CHART 6

ASSEMBLY 7

HOW TO USE THE HYBRID TRAINER 16

HOW TO USE THE CONSOLE 18

IC INFORMATION 24

MAINTENANCE AND TROUBLESHOOTING 25

EXERCISE GUIDELINES 27

PART LIST 28

EXPLODED DRAWING 30

ORDERING REPLACEMENT PARTS Back Cover

LIMITED WARRANTY Back Cover

WARNING DECAL PLACEMENT

This drawing shows the location(s) of the warning decal(s). **If a decal is missing or illegible, see the front cover of this manual and request a free replacement decal. Apply the decal in the location shown.** Note: The decal(s) may not be shown at actual size.

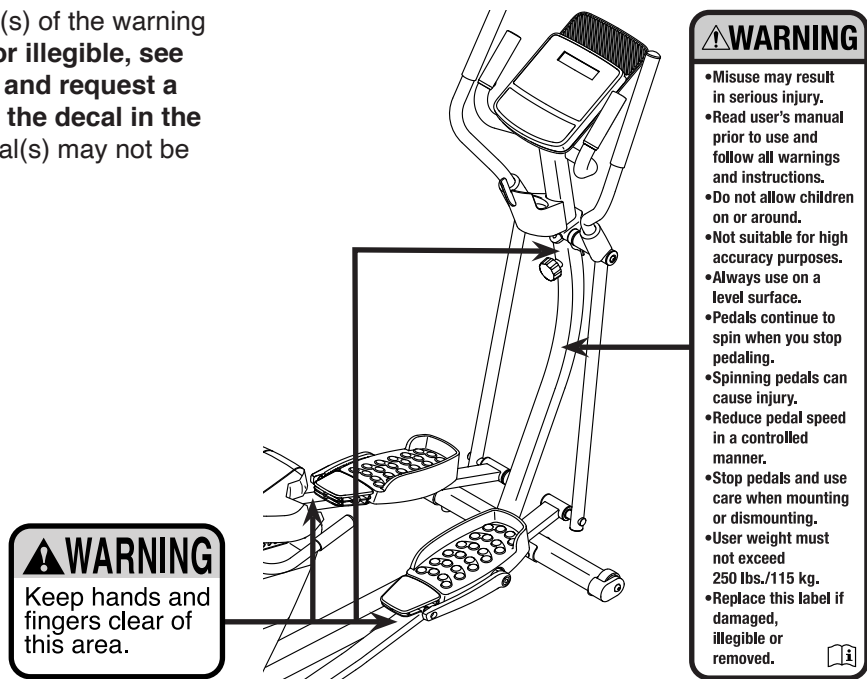

PROFORM and IFIT are registered trademarks of iFIT Inc. App Store is a trademark of Apple Inc., registered in the U.S. and other countries. Android and Google Play are trademarks of Google LLC. The Bluetooth® word mark and logos are registered trademarks of Bluetooth SIG, Inc. and are used under license. IOS is a trademark or registered trademark of Cisco in the U.S. and other countries and is used under license.

IMPORTANT PRECAUTIONS

⚠️ WARNING: To reduce the risk of serious injury, read all important precautions and instructions in this manual and all warnings on your hybrid trainer before using your hybrid trainer. iFIT assumes no responsibility for personal injury or property damage sustained by or through the use of this product.

1. It is the responsibility of the owner to ensure that all users of the hybrid trainer are adequately informed of all precautions.
2. Keep children under age 16 and pets away from the hybrid trainer at all times.
3. Consult your health care provider before beginning any exercise program. This is especially important for persons over age 35 or persons with pre-existing health problems.
4. Consult your health care provider before beginning or continuing any exercise program during pregnancy. Use the hybrid trainer only as authorized by your health care provider.
5. The hybrid trainer is not intended for use by persons with reduced physical, sensory, or mental capabilities or lack of experience and knowledge, unless they are given supervision or instruction about use of the hybrid trainer by someone responsible for their safety.
6. Use the hybrid trainer only as described in this manual.
7. The hybrid trainer is intended for home use only. Do not use the hybrid trainer in a commercial, rental, or institutional setting.
8. Keep the hybrid trainer indoors, away from moisture and dust. Do not put the hybrid trainer in a garage or covered patio or near water.
9. Place the hybrid trainer on a level surface, with at least 3 ft. (0.9 m) of clearance in the front and rear of the hybrid trainer and 2 ft. (0.6 m) on each side. To protect the floor or carpet from damage, place a mat under the hybrid trainer.
10. Inspect and properly tighten all parts each time the hybrid trainer is used. Replace any worn parts immediately. Use only manufacturer-supplied parts.
11. The hybrid trainer should not be used by persons weighing more than 250 lbs. (115 kg).
12. Wear appropriate clothes while exercising; do not wear loose clothes that could become caught on the hybrid trainer. Always wear athletic shoes for foot protection while exercising.
13. Hold the handlebars or the upper body arms when mounting, dismounting, or using the hybrid trainer.
14. The hybrid trainer does not have a freewheel; the pedals will continue to move until the flywheel stops. Reduce your pedaling speed in a controlled way.
15. Keep your back straight while using the hybrid trainer; do not arch your back.
16. Over exercising may result in serious injury or death. If you feel faint, if you become short of breath, or if you experience pain while exercising, stop immediately and cool down.

PROTECT

YOUR FITNESS EQUIPMENT
WITH AN EXTENDED SERVICE PLAN



Your new fitness equipment represents a significant investment in your health. Protect your investment now from unexpected mechanical or electrical failures for up to five years.

PLAN FEATURES

- Protection for one to five years
- Over 100 authorized repair centers
- Highly trained repair technicians
- A national toll-free repair hotline
- Simple repair claim procedure
- No claim forms
- Easy enrollment
- Service available within 100 miles (161 km) of nearest authorized repair center
- In-home repairs covered
- Parts and labour covered
- Mechanical and electrical failures covered

To protect your fitness equipment today, please
call Customer Service at **1-888-936-4266**
Or, email us at customerservice@iconcanada.ca

iFIT 
iFIT Health & Fitness Inc.

BEFORE YOU BEGIN

Thank you for selecting the revolutionary PROFORM® HYBRID TRAINER. The HYBRID TRAINER provides an impressive selection of features designed to make your workouts at home more effective and enjoyable.

For your benefit, read this manual carefully before you use the hybrid trainer. If you have questions after reading this manual, please see the front cover of this

manual. To help us assist you, note the product model number and serial number before contacting us. The model number and the location of the serial number decal are shown on the front cover of this manual.

Before reading further, please familiarize yourself with the parts that are labeled in the drawing below.

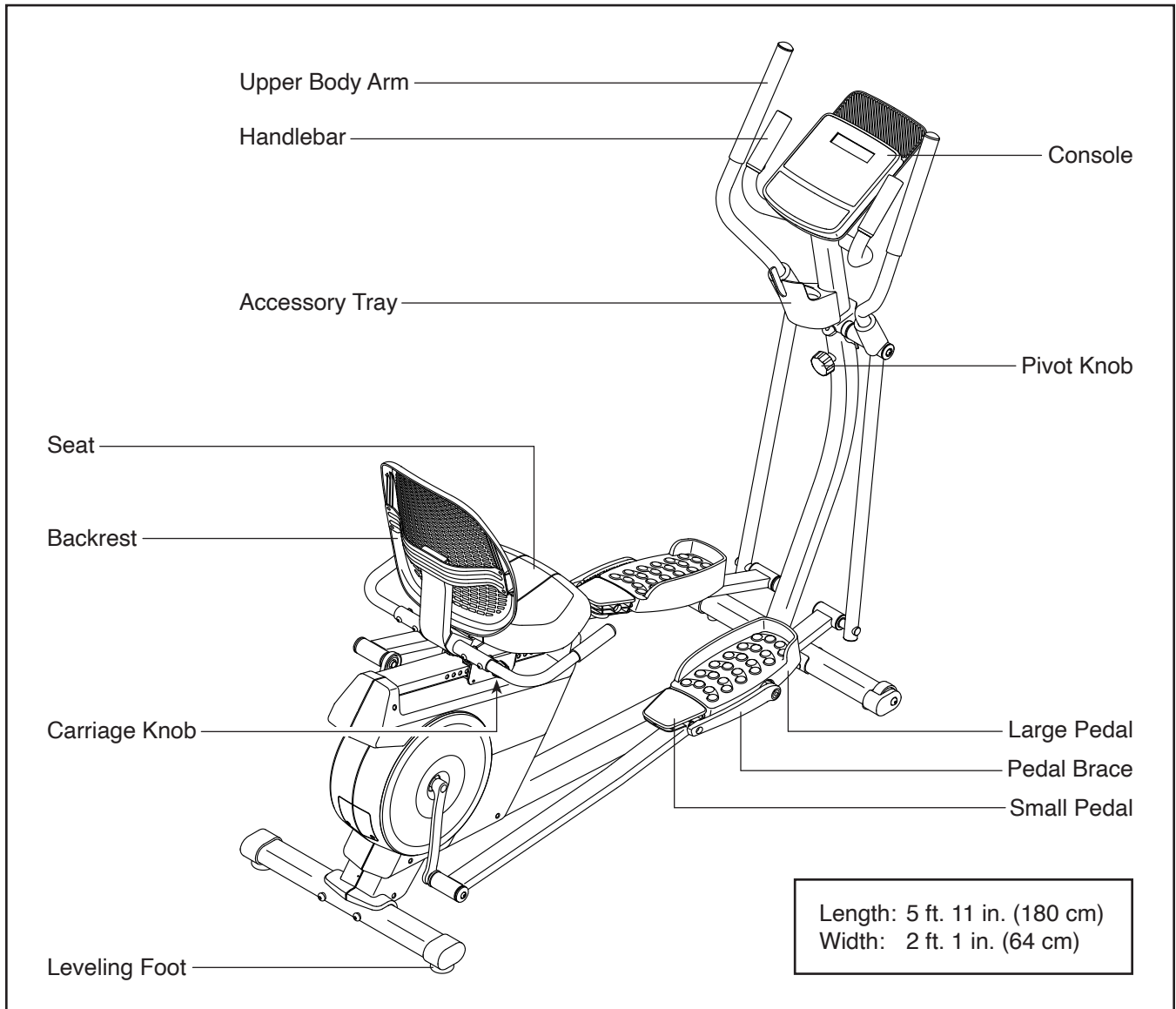

PART IDENTIFICATION CHART

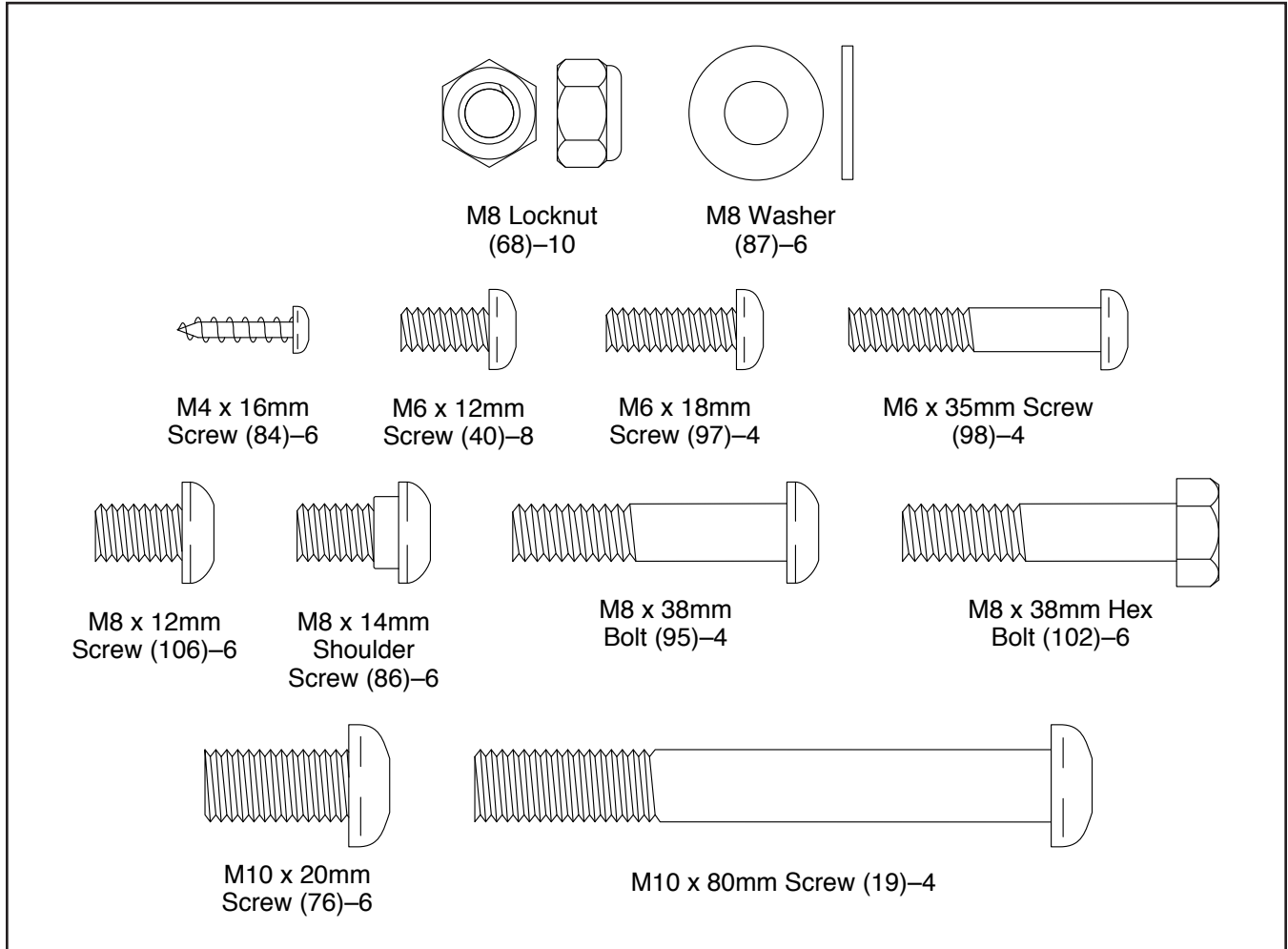

Use the drawings below to identify the small parts needed for assembly. The number in parentheses below each drawing is the key number of the part, from the PART LIST near the end of this manual. The number following the key number is the quantity needed for assembly. **Note: If a part is not in the hardware kit, check to see if it has been preassembled. Extra parts may be included.**



ASSEMBLY

- Assembly requires two persons.
- Place all parts in a cleared area and remove the packing materials. Do not dispose of the packing materials until you finish assembly.
- Left parts are marked “L” or “Left” and right parts are marked “R” or “Right.”
- To identify small parts, see page 6.

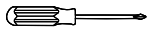
- In addition to the included tool(s), assembly requires the following tools:

- one Phillips screwdriver 
- one adjustable wrench 
- one rubber mallet 

Assembly may be easier if you have a set of wrenches. To avoid damaging parts, do not use power tools.

1. Go to iconservice.ca/CustomerService/registration and register your product.

- documents your ownership
- activates your warranty
- ensures priority customer support if assistance is ever needed

Note: If you do not have internet access, call Member Care (see the front cover of this manual) and register your product.

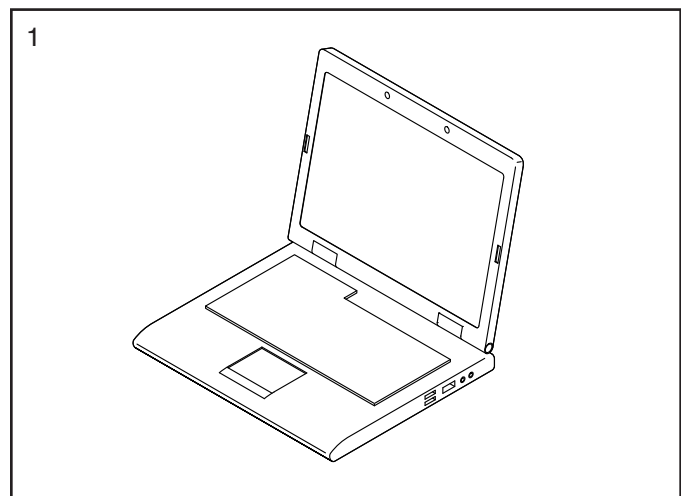

2. With the help of a second person, place some of the packing materials (not shown) under the Frame (1).

Orient the Rear Stabilizer (6) so that the large holes (A) are facing the Frame (1). Attach the Rear Stabilizer to the Frame with two M10 x 80mm Screws (19).

Then, remove the packing materials from under the Frame (1).

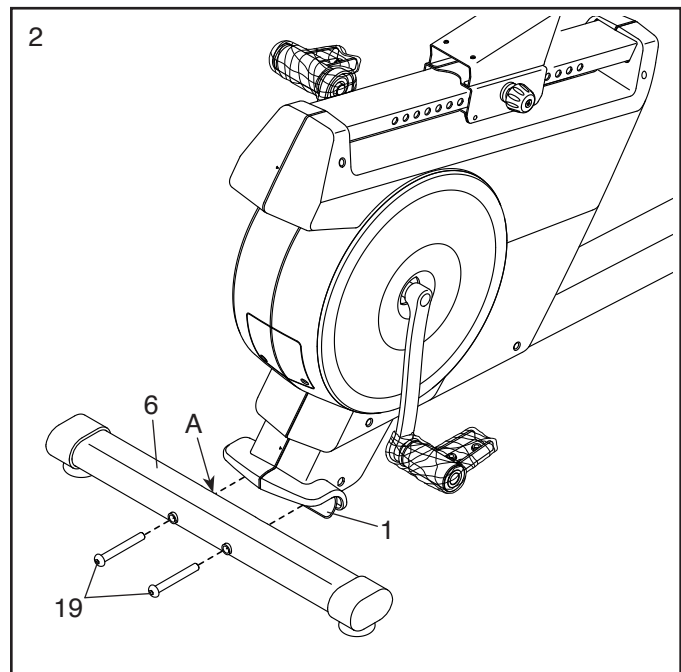

3. Orient the Upright (2) and the Front Stabilizer (5) so that the large holes (B) are facing the Upright.

Attach the Front Stabilizer (5) to the Upright (2) with two M10 x 80mm Screws (19).

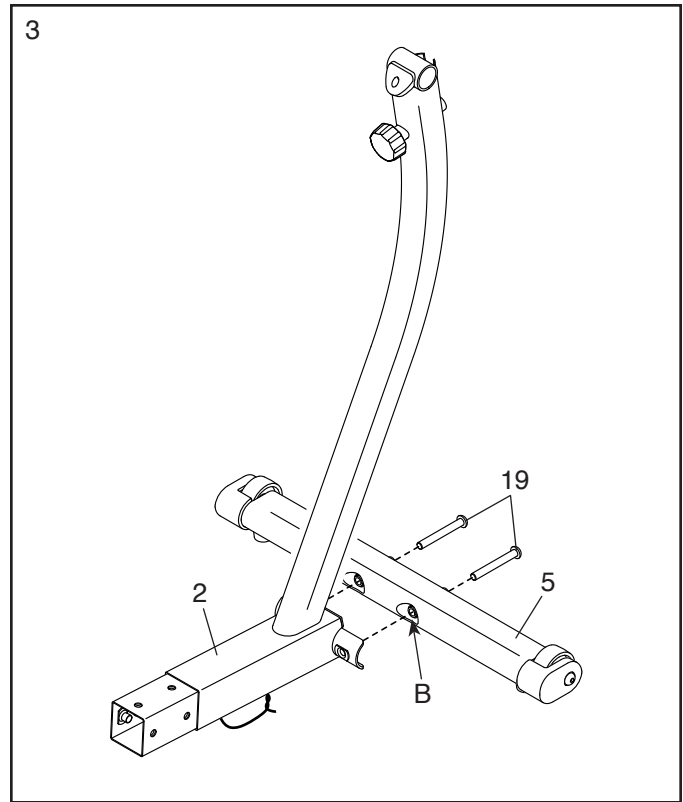

4. Set the Upright (2) near the Frame (1) as shown.

Locate the wire tie (C) in the Frame (1), and pull the Main Wire (96) out of the underside of the Frame.

Repeat this action to pull the Upper Wire (not shown) out of the underside of the Upright (2).

Then, untie and discard the wire ties (C, D).

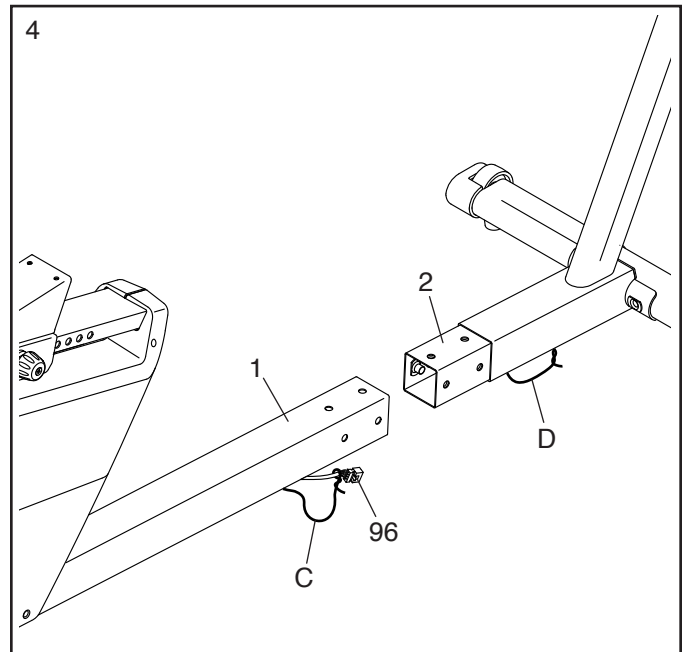

5. **Tip: Avoid pinching the wires.** Insert the Upright (2) into the Frame (1).

Attach the Upright (2) with six M10 x 20mm Screw (76); **start all the Screws, and then tighten them.**

Then, connect the Upper Wire (94) to the Main Wire (96). **Tip: The wire connectors should slide together easily and snap into place with an audible click. If they do not, turn one connector and try again.**

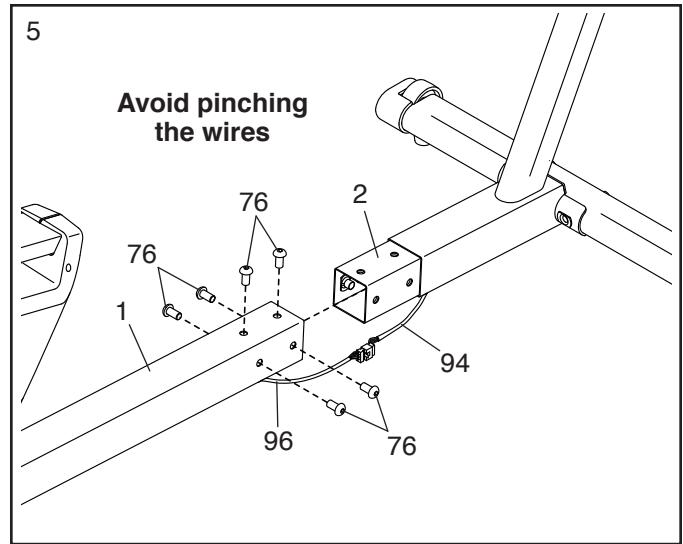

6. Locate the wire tie (E) in the top of the Upright (2), and pull the Upper Wire (94) out of the Upright. Then, untie and discard the wire tie.

Tip: Avoid pinching the wires. Attach the Wire Cover (20) to the Frame (1) and the Upright (2) with two M4 x 16mm Screws (84). **Make sure that the tab (F) on the Wire Cover is in the location shown.**

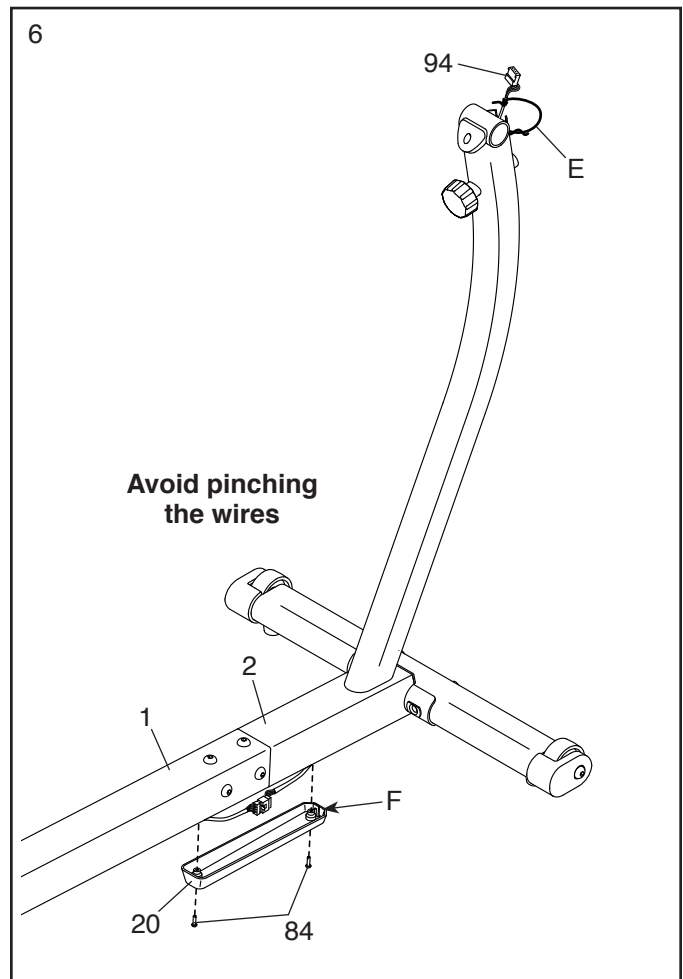

7. Have a second person hold the Pivot Bracket (3) near the Upright (2).

Locate the wire tie (G) in the Pivot Bracket (3). Tie the wire tie to the Upper Wire (94) and then pull the other end of the wire tie until the Upper Wire is routed through the Pivot Bracket.

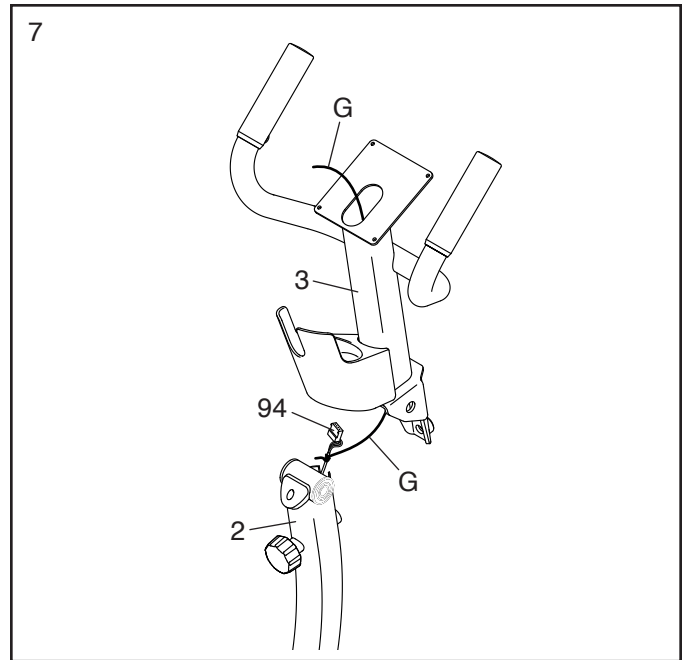

8. Using a plastic bag to keep your fingers clean, apply a generous amount of the included grease to the Pivot Axle (80).

Tip: Avoid pinching the Upper Wire (94). Slide the Pivot Bracket (3) onto the Upright (2) and hold it in place.

Next, insert the Pivot Axle (80) into the Pivot Bracket (3) and into the Upright (2). Center the Pivot Axle.

Then, tighten the Pivot Knob (13) into the Pivot Bracket (3).

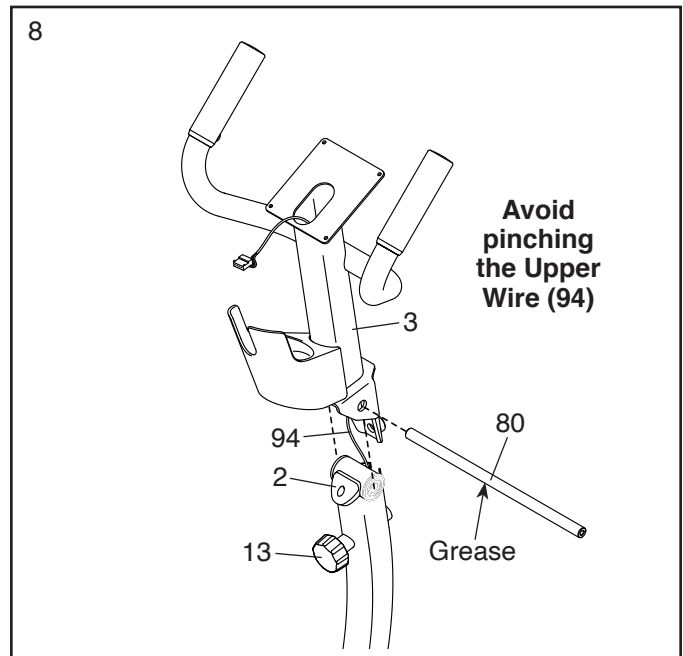

9. Identify the Right Pedal Arm (9) and the Right Large Pedal (70), and orient them as shown.

Attach the Right Large Pedal (70) to the Right Pedal Arm (9) with four M6 x 12mm Screws (40); **start all the Screws, and then tighten them.**

Repeat this step for the Left Pedal Arm (not shown) and the Left Large Pedal (not shown).

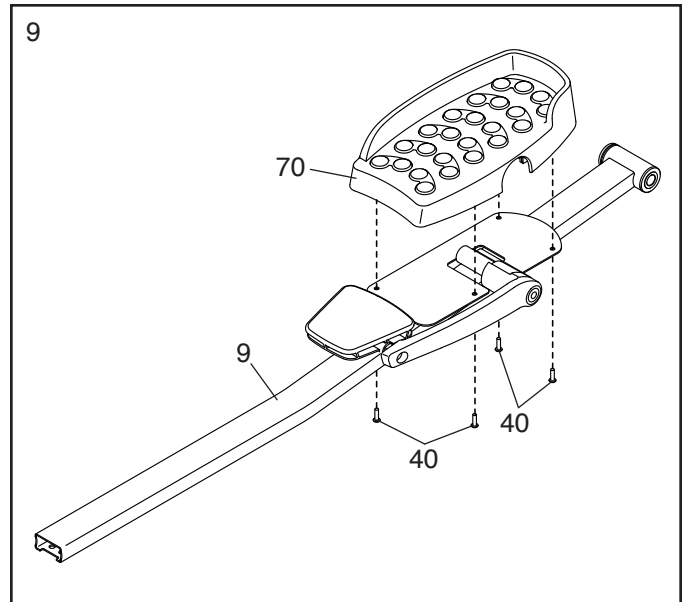

10. Apply a generous amount of the included grease to the axle on the Right Pivot Leg (8).

Then, slide the Right Pedal Arm (9) onto the Right Pivot Leg (8). Attach the Right Pedal Arm with an M8 x 14mm Shoulder Screw (86), a Pivot Cover (83), and an M8 Washer (87).

Repeat this step for the Left Pedal Arm (not shown) and the Left Pivot Leg (not shown).

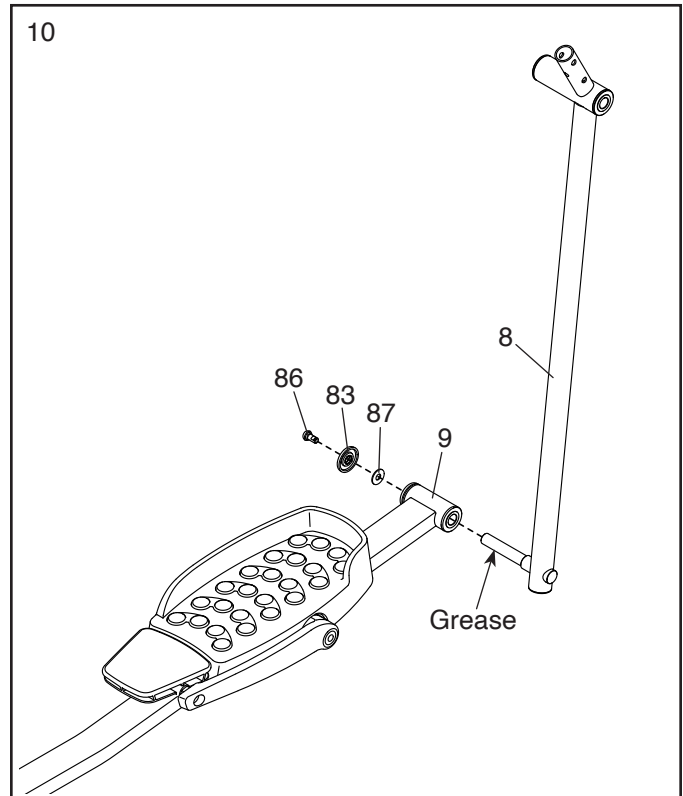

11. Slide a Pivot Spacer (79) onto each side of the Pivot Axle (80).

Then, slide the Right and Left Pivot Legs (8, 11) onto the Pivot Axle (80); **make sure that the Pivot Legs are on the correct sides.**

Then, tighten an M8 x 14mm Shoulder Screw (86) with a Pivot Cover (83) and an M8 Washer (87) into each end of the Pivot Axle (80) **at the same time.**

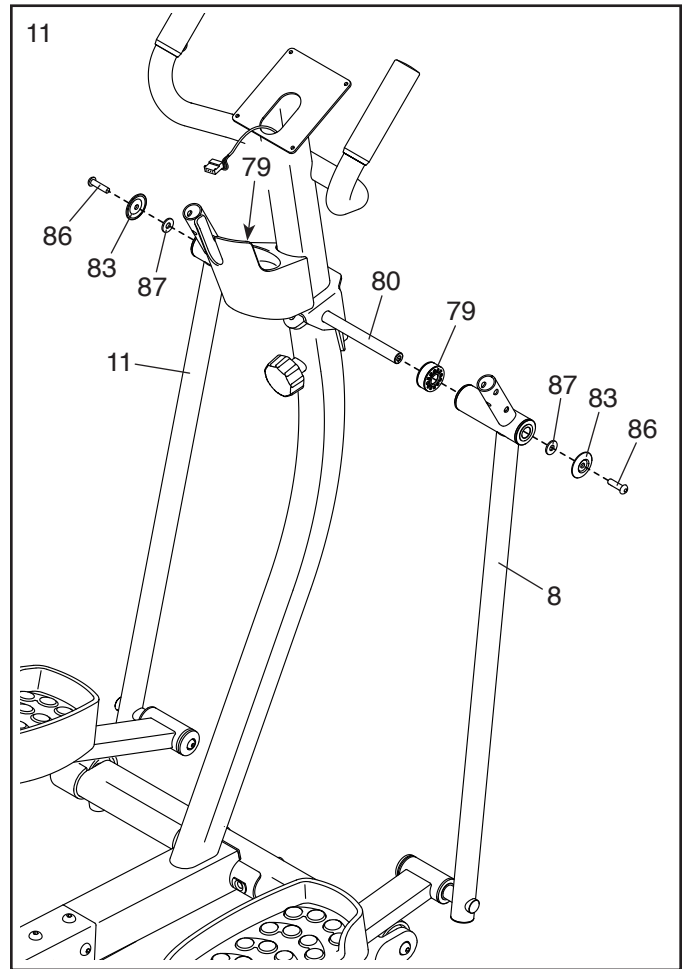

12. Remove and discard the packaging on the Right Crank Bracket (30). Then, tighten an M8 x 14mm Shoulder Screw (86) with a Pivot Cover (83) and an M8 Washer (87) into the right Crank Arm (24).

Next, slide the Right Pedal Arm (9) onto the Right Crank Bracket (30).

Then, attach the Right Pedal Arm (9) with three M8 x 12mm Screws (106); **start all the Screws, and then tighten them.**

Repeat this step on the other side of the hybrid trainer.

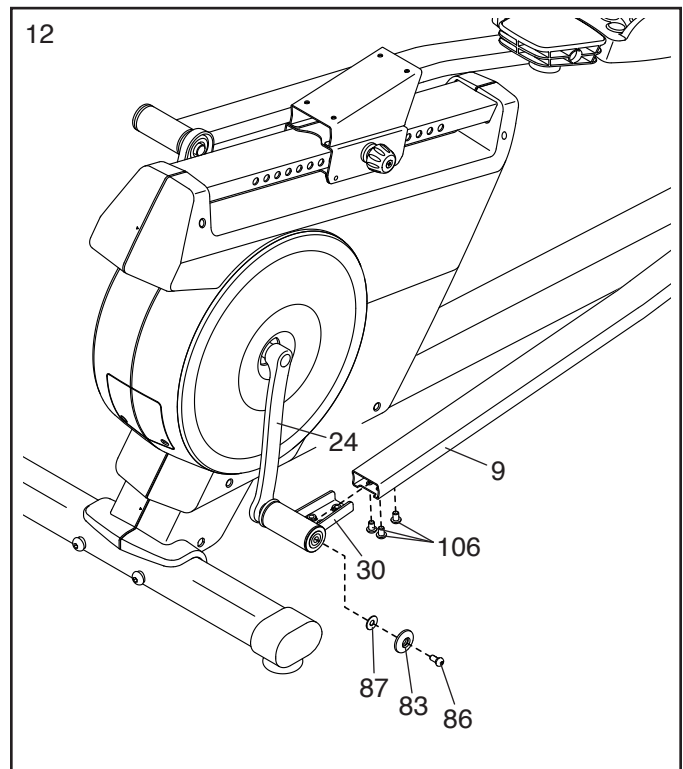

13. Untie and discard the wire tie on the Upper Wire (94).

While a second person holds the Console (4) near the Pivot Bracket (3), plug the Upper Wire (94) into the receptacle on the Console. **Tip: The wire connector should slide in easily and snap into place with an audible click. If it does not, turn the connector and try again.**

Insert the excess wire into the Pivot Bracket (3).

Tip: Avoid pinching the wires. Attach the Console (4) to the Pivot Bracket (3) with four M4 x 16mm Screws (84); **start all the Screws, and then tighten them.**

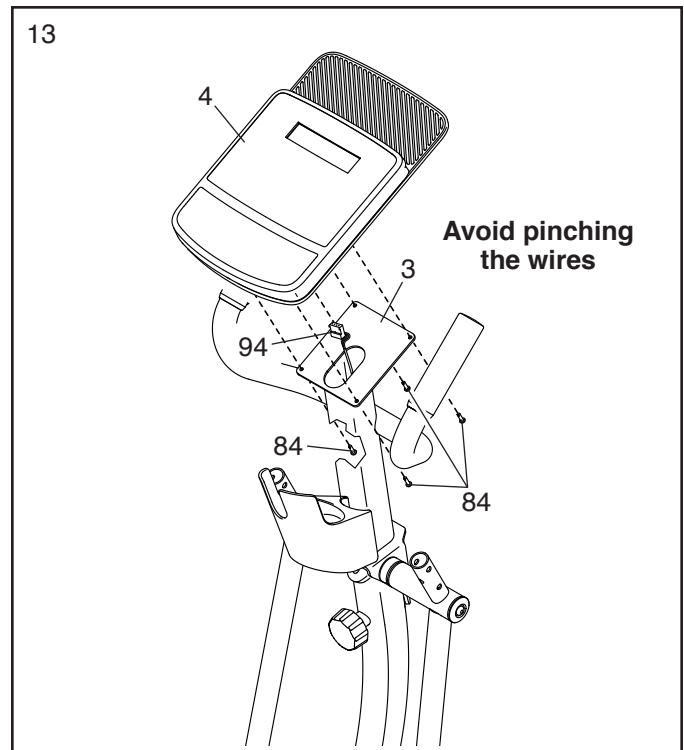

14. Identify the Right Upper Body Arm (7).

Orient an Upper Body Cover (78) as shown, and slide it upward onto the Right Upper Body Arm (7).

Attach the Right Upper Body Arm (7) to the Right Pivot Leg (8) with three M8 x 38mm Hex Bolts (102) and three M8 Locknuts (68); **start all the Hex Bolts, and then tighten them. Make sure that the Locknuts are inside of the hexagonal holes (H).**

Then, slide the Upper Body Cover (78) downward onto the Right Pivot Leg (8).

Repeat this step on the other side of the hybrid trainer.

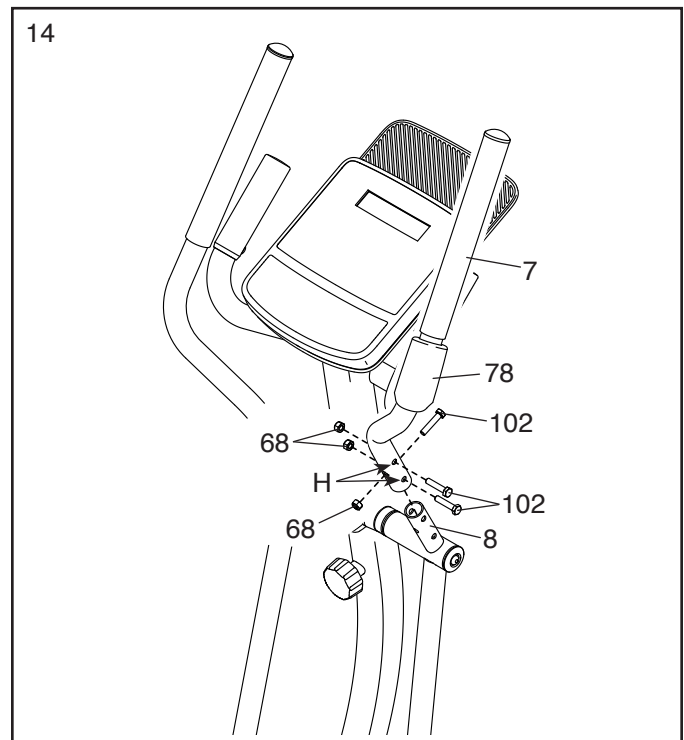

15. Orient the Seat Frame (61) as shown.

Insert a Seat Handlebar (29) into the Seat Frame (61). Attach the Seat Handlebar with two M8 x 38mm Bolts (95) and two M8 Locknuts (68); **make sure that the Locknuts are in the hexagonal holes (I).**

Repeat this step to attach the other Seat Handlebar (29).

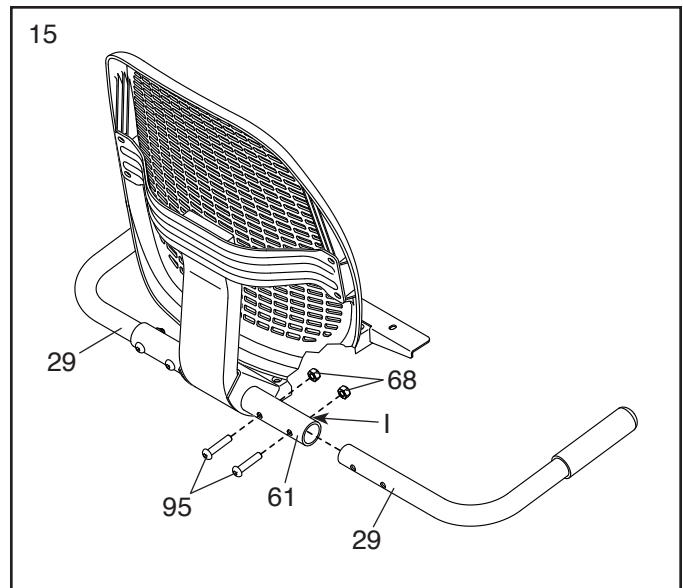

16. Attach the Seat Frame (61) to the Seat Carriage (32) with four M6 x 35mm Screws (98); **start all the Screws, and then tighten them.**

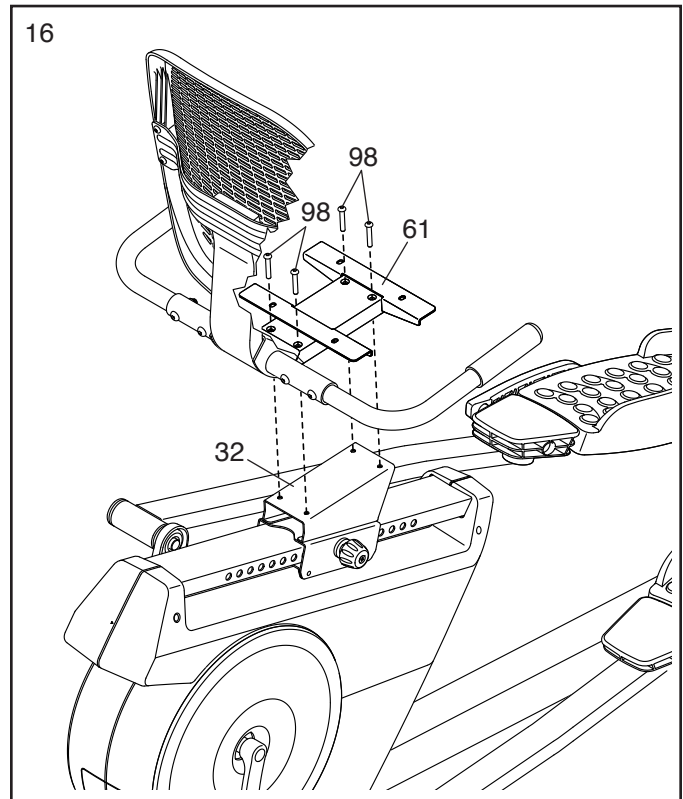

17. Attach the Seat (28) to the Seat Frame (61) with four M6 x 18mm Screws (97) (only two are shown); **start all the Screws, and then tighten them.**

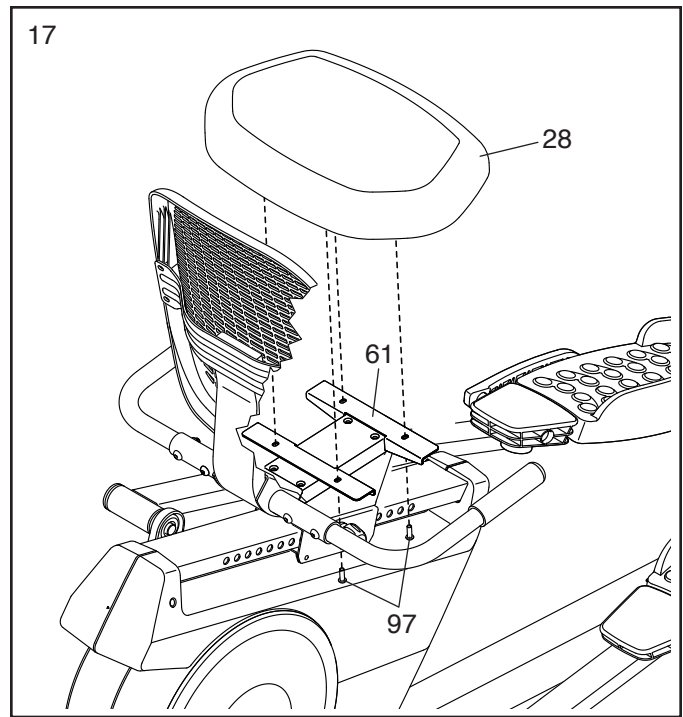

18. Plug the Power Adapter (104) into the receptacle on the rear of the hybrid trainer.

Note: To plug the Power Adapter (104) into an outlet, see HOW TO PLUG IN THE POWER ADAPTER on page 16.

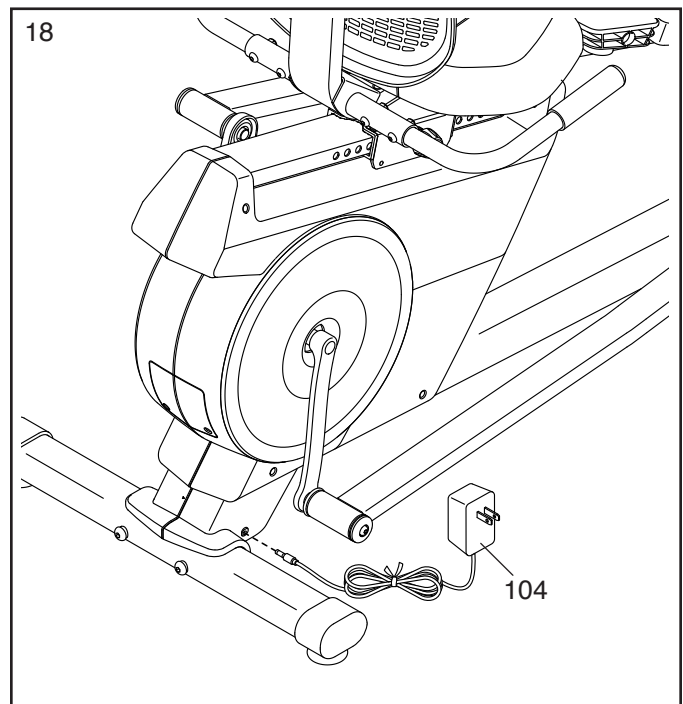

19. **Make sure that all parts of the hybrid trainer are properly tightened.** Extra parts may be included. To protect the floor or carpet from damage, place a mat under the hybrid trainer.

HOW TO USE THE HYBRID TRAINER

HOW TO PLUG IN THE POWER ADAPTER

IMPORTANT: If the hybrid trainer has been exposed to cold temperatures, allow it to warm to room temperature before you plug in the power adapter (A). If you do not do this, you may damage the console displays or other electronic components.

Plug the power adapter (A) into the receptacle on the frame of the hybrid trainer. Then, plug the power adapter into an appropriate outlet that is properly installed in accordance with all local codes and ordinances.

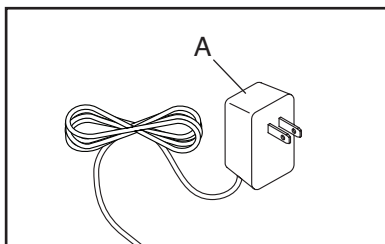

HOW TO MOVE THE HYBRID TRAINER

Take any necessary measures to protect your floor. Lift the rear stabilizer (B) until the hybrid trainer will roll on the wheels. Carefully move the hybrid trainer to the desired location, and then lower it to the floor.

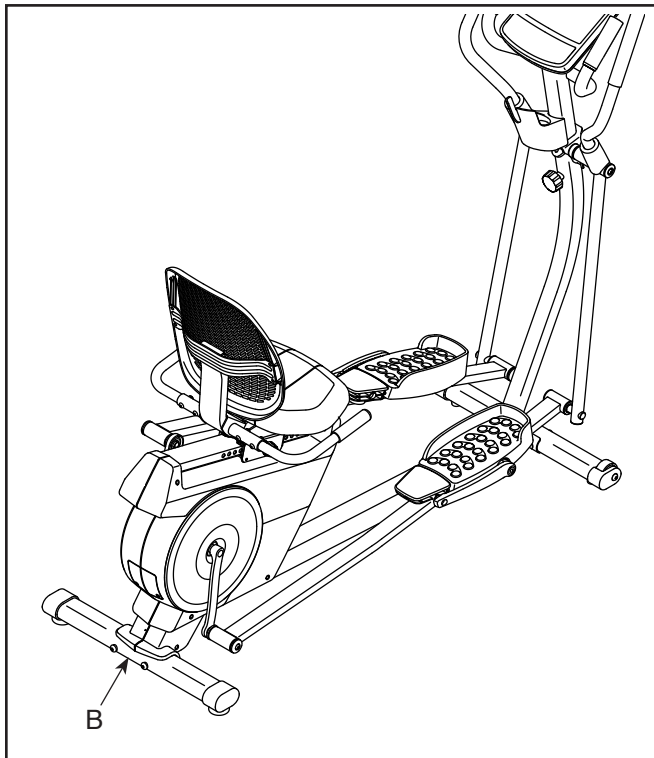

HOW TO LEVEL THE HYBRID TRAINER

If the hybrid trainer rocks slightly on your floor during use, turn one or both of the leveling feet (C) beneath the rear stabilizer until the rocking motion is eliminated.

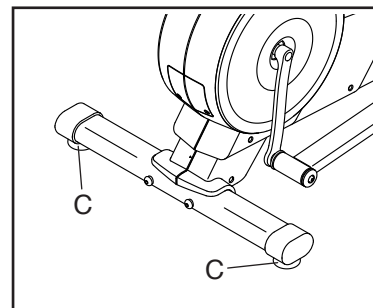

HOW TO USE THE ELLIPTICAL MODE

To use the hybrid trainer as an elliptical, first pivot the pivot bracket to the high position and tighten the pivot knob (D) into the upright.

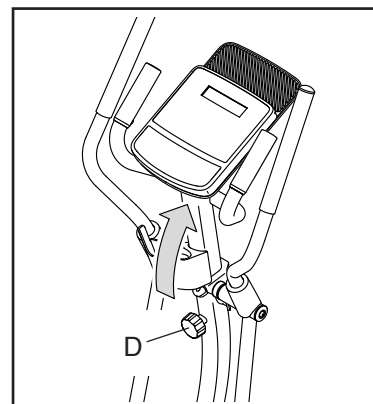

Then, pivot the right and left small pedals (E, F) to the low position.

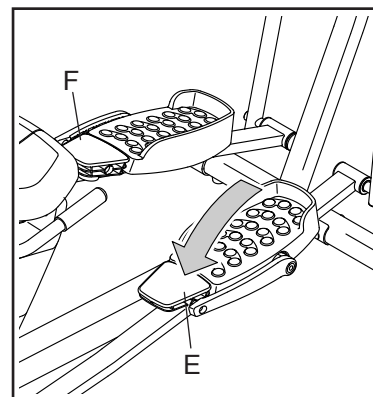

To mount the hybrid trainer in the elliptical mode, hold the handlebars (G) or the upper body arms (H) and step onto the pedal (I) that is in the lower position. Then, step onto the other pedal.

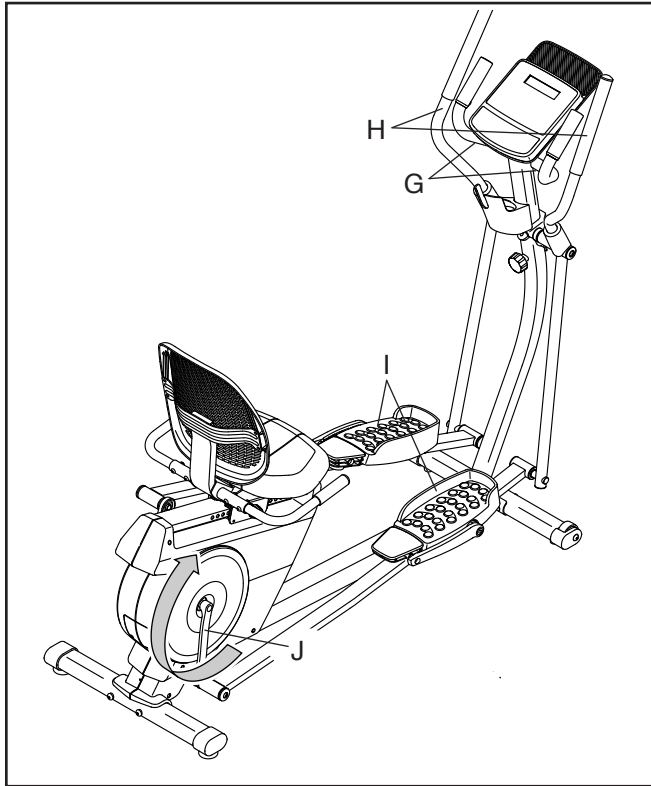

Push the pedals (I) until they begin to move with a continuous motion. **Note: The crank arms (J) can turn in either direction. It is recommended that you move the crank arms in the direction shown by the arrow; however, for variety, you can turn the crank arms in the opposite direction.**

To dismount the hybrid trainer, wait until the pedals (I) come to a complete stop. **Note: The hybrid trainer does not have a free wheel; the pedals will continue to move until the flywheel stops.** When the pedals are stationary, step off the higher pedal first. Then, step off the lower pedal.

HOW TO USE THE RECUMBENT BIKE MODE

To use the hybrid trainer as a recumbent bike, loosen the pivot knob (D) and pivot the pivot bracket to the low position.

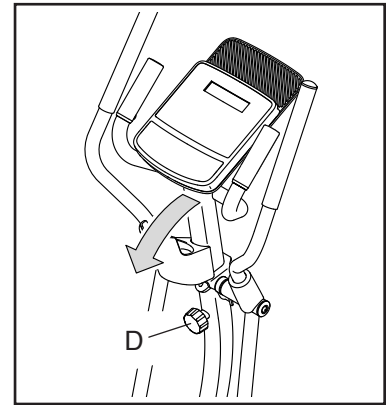

Next, pivot the right and left small pedals (E, F) to the high position.

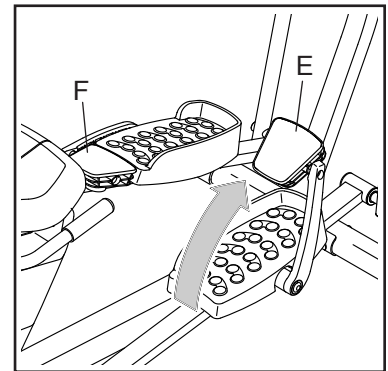

Then, adjust the seat forward or backward to the position that is the most comfortable. To adjust the seat, loosen the carriage knob (K) and pull it outward, slide the seat to the desired position, and then release the carriage knob into an adjustment hole on the frame. **Make sure that the carriage knob is securely inserted into an adjustment hole.** Then, tighten the carriage knob.

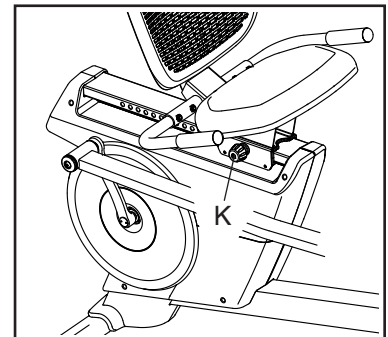

HOW TO USE THE CONSOLE

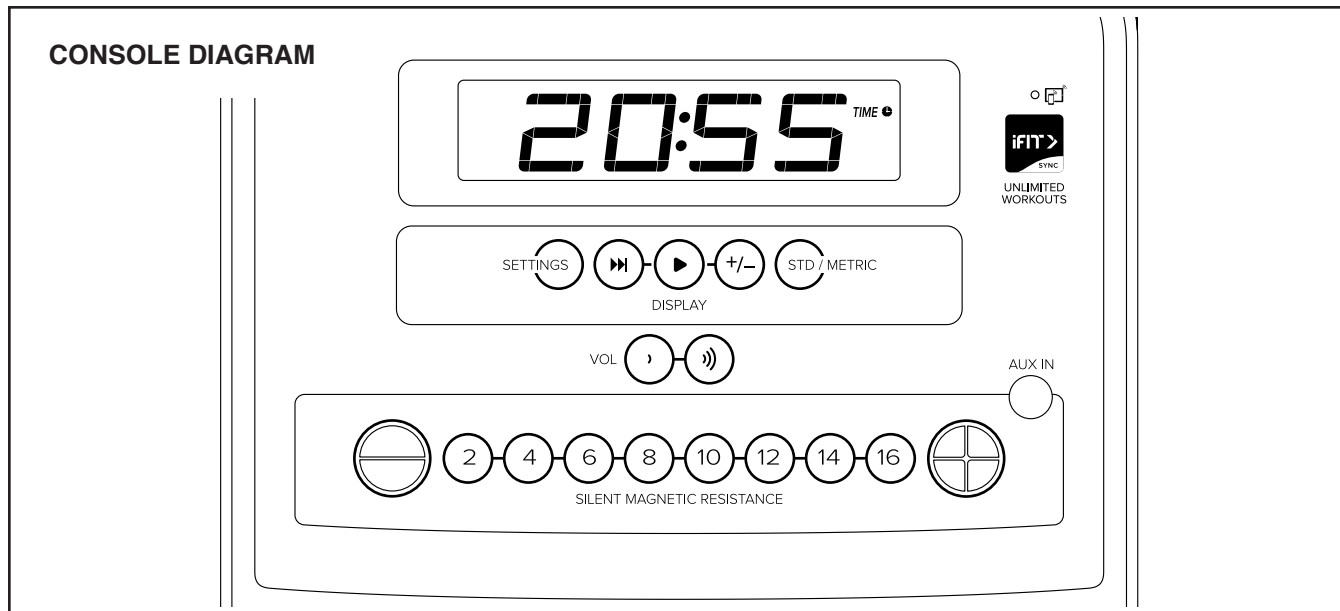

FEATURES OF THE CONSOLE

The advanced console offers an array of features designed to make your workouts more effective and enjoyable.

When you use the manual mode of the console, you can change the resistance of the pedals with the touch of a button. As you exercise, the console will provide continuous exercise feedback. You can even measure your heart rate using a compatible heart rate monitor.

You can also connect your personal audio player to the console sound system and listen to your favorite music or audio books while you exercise.

The console also offers unlimited iFIT workouts when you download the iFIT app to your smart device and connect it to the console.

With the iFIT app, you can access a large and varied library of iFIT video workouts, create your own workouts, track your workout results, and access many other features.

Each iFIT workout automatically changes the resistance of the pedals as an iFIT coach guides you through an immersive and effective video workout.

To use the manual mode, see page 19. **To use an iFIT workout**, see page 21. **To connect your heart rate monitor to the console**, see page 22. **To change console settings**, see page 23.

Note: If there is a sheet of plastic on the display, remove the plastic.

HOW TO USE THE MANUAL MODE

1. **Begin pedaling or press any button on the console to turn on the console.**

When you turn on the console, the display will turn on. The console will then be ready for use.

2. **Select the manual mode.**

When you turn on the console, the manual mode will be selected automatically.

3. **Change the resistance of the pedals as desired.**

Begin pedaling to start the manual mode.

As you pedal, you can change the resistance of the pedals. To change the resistance, press one of the numbered Silent Magnetic Resistance buttons or press the Silent Magnetic Resistance increase and decrease buttons.

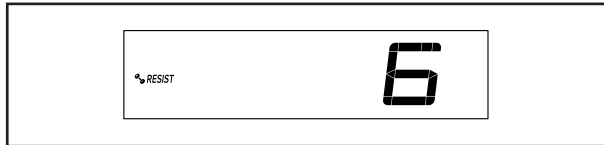

Note: After you press a button, it will take a moment for the pedals to reach the selected resistance level.

4. **Follow your progress with the display.**

The display can show the following workout information:

Calories (CALs)—The approximate number of calories you have burned.

Calories per Hour (CALs/HR)—The approximate number of calories you are burning per hour.

Distance (MI or KM)—The distance that you have pedaled in miles or kilometers. To change the unit of measurement, press the Std/Metric button.

Pace—Your pedaling speed in minutes per mile or minutes per kilometer. To change the unit of measurement, press the Std/Metric button.

Pulse (BPM and heart symbol)—Your heart rate when you use a compatible heart rate monitor (see step 5).

Resistance (RESIST)—The resistance level of the pedals.

RPM—Your pedaling speed in revolutions per minute (RPM).

Speed (MPH or KPH)—Your pedaling speed in miles per hour or kilometers per hour. To change the unit of measurement, press the Std/Metric button.

Time—The elapsed time.

Press the Display button (A) repeatedly to view the desired workout information in the display.

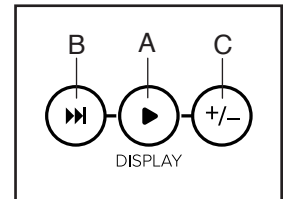

Scan mode—The console also has a scan mode that will display workout information in a repeating cycle. To turn on the scan mode, press the Scan button (B); the scan indicator (D) and the word SCAN will turn on in the display.



To manually advance the scan cycle, press the Scan button repeatedly.

To turn off the scan mode, press the Display button; the scan indicator and the word SCAN will turn off.

You can also customize the scan mode to display only the desired workout information in the repeating cycle.

To customize the scan mode, first press the Display button repeatedly until the workout information that you want to add to or remove from the scan cycle appears in the display.

Next, press the Add/Remove button (C) to add or remove that workout information from the scan cycle.

When workout information is added, its indicator will turn on

in the display. **When workout information is removed**, its indicator will turn off.

Then, press the Scan button to turn on the scan mode.

Note: The console will show your heart rate in the scan cycle automatically whenever it detects a pulse from a heart rate monitor.

To pause the console, simply stop pedaling. When the console is paused, the time will flash in the display. To continue your workout, simply resume pedaling.

Note: The console can show speed and distance in standard or metric units of measurement. To change the unit of measurement, press the Std/Metric button.

5. Wear a compatible heart rate monitor and measure your heart rate if desired.

You can wear a compatible heart rate monitor to measure your heart rate. Note: The console is compatible with all Bluetooth® Smart heart rate monitors.

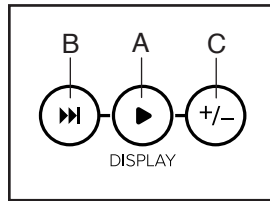

A compatible heart rate monitor is included with some models. If a heart rate monitor is included, see THE HEART RATE MONITOR in this manual to learn how to use it.

If this model does not include a compatible heart rate monitor, see page 22 for information about ordering one.

To connect a compatible heart rate monitor to the console, press the iFIT Sync button on the console; the console pairing number will appear in the display. When a connection is established, the LED on the console will flash red twice. When your heart-beat is detected, your heart rate will be shown. See HOW TO CONNECT YOUR HEART RATE MONITOR TO THE CONSOLE on page 22 for more information.

6. When you are finished exercising, the console will turn off automatically.

If the pedals do not move for several seconds, the console will pause and the time will flash in the display. To resume your workout, simply resume pedaling.

If the pedals do not move for several minutes and the buttons are not pressed, the console will turn off and the display will be reset.

Note: The console features a demo mode, designed to be used if the hybrid trainer is displayed in a store. If the demo mode is turned on, the console will not turn off and the display will not be reset when you finish exercising. To turn off the demo mode, see HOW TO CHANGE CONSOLE SETTINGS on page 23.

HOW TO USE AN IFIT WORKOUT

The console offers access to a large and varied library of iFIT workouts when you download the iFIT app to your smart device and connect it to the console.

Note: The console supports Bluetooth connections to smart devices via the iFIT app and to compatible heart rate monitors. Other Bluetooth connections are not supported.

1. Download and install the iFIT app on your smart device.

On your iOS® or Android™ smart device, open the App StoreSM or the Google Play™ store, search for the free iFIT app, and then install the app on your smart device. **Make sure that the Bluetooth option is enabled on your smart device.**

Then, open the iFIT app and follow the instructions to set up an iFIT account and customize settings.

Take time to explore the iFIT app and learn about its features and settings.

2. Connect your heart rate monitor to the console if desired.

If you are connecting both your heart rate monitor and your smart device to the console, **you must connect your heart rate monitor before you connect your smart device.** See HOW TO CONNECT YOUR HEART RATE MONITOR TO THE CONSOLE on page 22.

3. Connect your smart device to the console.

Press the iFIT Sync button on the console; the console pairing number will appear in the display. Then, follow the instructions in the iFIT app to connect your smart device to the console.

When a connection is established, the LED on the console will turn solid blue.

4. Select an iFIT workout.

In the iFIT app, touch the buttons at the bottom of the screen to select either the main menu (Home button) or the workout library (Browse button).

To select a workout from the main menu or the workout library, simply touch the desired workout button on the screen. Slide or flick the screen to scroll upward or downward if necessary.

When you select a workout, the screen will show an overview of the workout that includes details such as the duration and distance of the workout and the approximate number of calories you will burn during the workout.

5. Start the workout.

Touch *Start Workout* to start the workout.

During some workouts, an iFIT coach will guide you through an immersive video workout. Touch the screen in any open space to view and select music, trainer voice, and volume options for the workout.

During some workouts, the screen will show a map of the route and a marker indicating your progress. Touch the buttons on the screen to select the desired map options.

If the resistance setting for the current segment of the workout is too high or too low, you can manually override the setting by pressing the Silent Magnetic Resistance buttons on the console. **IMPORTANT: When the current segment ends, the resistance will automatically adjust to the resistance setting programmed for the next segment.**

Note: The calorie goal shown in the workout description is an estimate of the number of calories that you will burn during the workout. The actual number of calories that you burn will depend on various factors, such as your weight. In addition, if you manually change the resistance level during the workout, the number of calories you burn will be affected.

To pause the workout, simply touch the screen or stop pedaling. To continue the workout, simply resume pedaling.

To end the workout, touch the screen to pause the workout, and then follow the prompts on the screen to end the workout and return to the main menu.

When the workout ends, a workout summary will appear on the screen. If desired, you can select options such as adding the workout to your schedule or adding the workout to your favorites list. Then, touch *Finish* to return to the main menu.

6. Disconnect your smart device from the console.

To disconnect your smart device from the console, first select the disconnect option in the iFIT app. Then, press and hold the iFIT Sync button on the console until the LED on the console turns solid green.

Note: All Bluetooth connections between the console and other devices (including any smart devices, heart rate monitors, and so forth) will be disconnected.

7. When you are finished exercising, the console will turn off automatically.

If the pedals do not move for several seconds, the console will pause.

If the pedals do not move for several minutes and the buttons are not pressed, the console will turn off and the display will be reset.

HOW TO CONNECT YOUR HEART RATE MONITOR TO THE CONSOLE

The console is compatible with all Bluetooth Smart heart rate monitors.

To connect your Bluetooth Smart heart rate monitor to the console, press the iFIT Sync button on the console; the console pairing number will appear in the display. When a connection is established, the LED on the console will flash red twice.

Note: If there is more than one compatible heart rate monitor near the console, the console will connect to the heart rate monitor with the strongest signal.

To disconnect your heart rate monitor from the console, press and hold the iFIT Sync button on the console until the LED on the console turns solid green.

Note: All Bluetooth connections between the console and other devices (including any smart devices, heart rate monitors, and so forth) will be disconnected.

THE OPTIONAL HEART RATE MONITOR

Whether your goal is to burn fat or to strengthen your cardiovascular system, the key to achieving the best results is to maintain the proper heart rate during your workouts. The optional heart rate monitor will enable you to continuously monitor your heart rate while you exercise, helping you to reach your personal fitness goals. **To purchase an optional heart rate monitor, please see the front cover of this manual.**

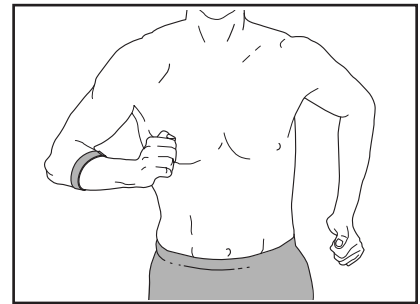

Note: The console is compatible with all Bluetooth Smart heart rate monitors.

HOW TO CHANGE CONSOLE SETTINGS

1. Select the settings mode.

To select the settings mode, press the Settings button. The first settings screen will appear in the display.

Note: If you are using the manual mode or an iFIT workout, end your workout before you press the Settings button.

2. Navigate the settings mode.

While the settings mode is selected, you can navigate through several settings screens. Press the Display button repeatedly to select the desired settings screen.

3. Change settings as desired.

Software Version Number—The software version number will appear in the display.

Unit of Measurement—The currently selected unit of measurement will appear in the display. The console can show speed and distance in standard or metric units of measurement. To change the unit of measurement, press the Std/Metric button repeatedly. To view workout information in standard units, select STD. To view workout information in metric units, select MET.



Display Test—This screen is intended to be used by service technicians to identify whether the display is working correctly.

Button Test—This screen is intended to be used by service technicians to identify whether a certain button is working correctly.

Total Time—The word TIME will appear in the display. The display will show the total number of hours that the hybrid trainer has been used.

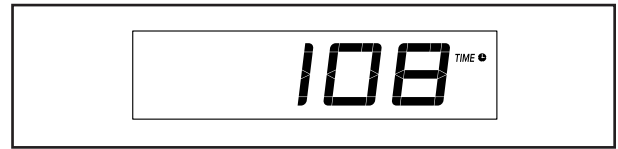

Total Distance—The letters MI or KM will appear in the display. The display will show the total distance (in miles or kilometers) that the hybrid trainer has been pedaled.

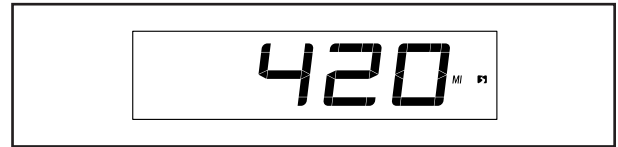

Contrast Level—The currently selected contrast level will appear in the display. Press the Silent Magnetic Resistance increase and decrease buttons to adjust the contrast level.

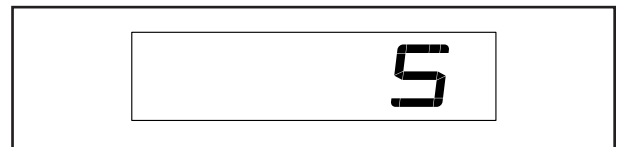

Demo Mode—The currently selected demo mode option will appear in the display. The console features a demo mode, designed to be used if the hybrid trainer is displayed in a store. If the demo mode is turned on, the console will not turn off and the display will not be reset when you finish exercising. Press the Silent Magnetic Resistance increase button repeatedly to select a demo mode option. To turn on the demo mode, select DON. To turn off the demo mode, select DOFF.



4. Exit the settings mode.

Press the Settings button to exit the settings mode.

IC INFORMATION

This device contains licence-exempt transmitter(s)/receiver(s) that comply with Innovation, Science and Economic Development Canada's licence-exempt RSS(s). Operation is subject to the following two conditions: 1. This device may not cause interference. 2. This device must accept any interference, including interference that may cause undesired operation of the device.

IMPORTANT: To satisfy exposure compliance requirements, the antenna and transmitter in the console must be at least 8 in. (20 cm) from all persons and must not be near or connected to any other antenna or transmitter.

CAN ICES-3 (B)/NMB-3(B)

Note: The console contains IC ID: 3673A-OMCBMD1.

MAINTENANCE AND TROUBLESHOOTING

MAINTENANCE

Regular maintenance is important for optimal performance and to reduce wear. Inspect and properly tighten all parts each time the hybrid trainer is used. Replace any worn parts immediately. Use only manufacturer-supplied parts.

To clean the hybrid trainer, use a damp cloth and a small amount of mild soap. **IMPORTANT: To avoid damage to the console, keep liquids away from the console and keep the console out of direct sunlight.**

CONSOLE TROUBLESHOOTING

If the console does not turn on, make sure that the power adapter is fully plugged in.

If a replacement power adapter is needed, call the telephone number on the cover of this manual. IMPORTANT: To avoid damaging the console, use only a manufacturer-supplied regulated power adapter.

HOW TO ADJUST THE REED SWITCH

If the console does not display correct feedback, the reed switch should be adjusted. To adjust the reed switch, first **unplug the power adapter**.

Remove the two M4 x 16mm Screws (84) from the Rear Access Cover (26), and then remove the Rear Access Cover.

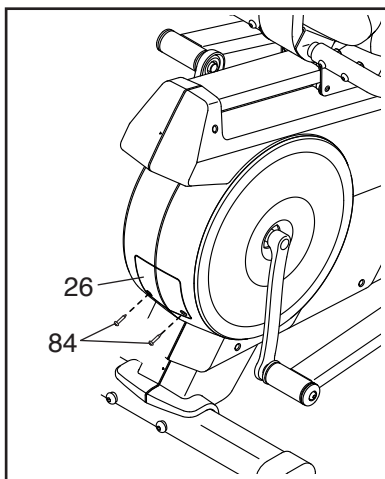

Next, locate the Reed Switch (60). Slightly loosen the two M4 x 16mm Screws (84).

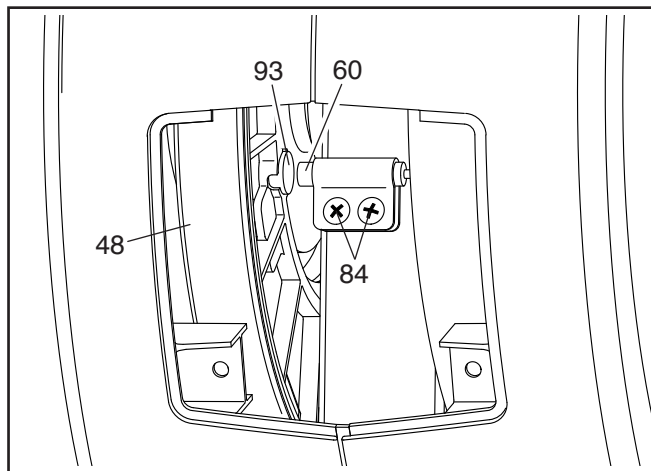

Next, rotate the Large Pulley (48) until a Pulley Magnet (93) is aligned with the Reed Switch (60). Slide the Reed Switch slightly toward or away from the Pulley Magnet. Then, retighten the M4 x 16mm Screws (84).

Plug in the power adapter and rotate the Large Pulley (48) for a moment. Repeat these actions until the console displays correct feedback.

When the reed switch is correctly adjusted, reattach the rear access cover and plug in the power adapter.

HOW TO ADJUST THE DRIVE BELT

If you can feel the pedals slip while you are pedaling, even when the resistance is adjusted to the highest level, the drive belt may need to be adjusted.

To adjust the drive belt, first **unplug the power adapter**. Next, remove the M4 x 16mm Screw (84) from the Side Access Cover (21), and then remove the Side Access Cover by moving it in the direction shown by the arrow.

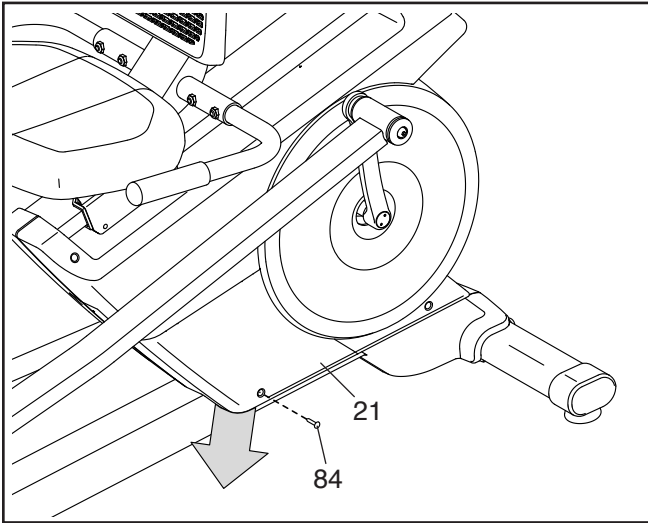

Loosen the M10 x 55mm Shoulder Bolt (99). Then, tighten the M8 Locknut (68) until the Drive Belt (64) is tight.

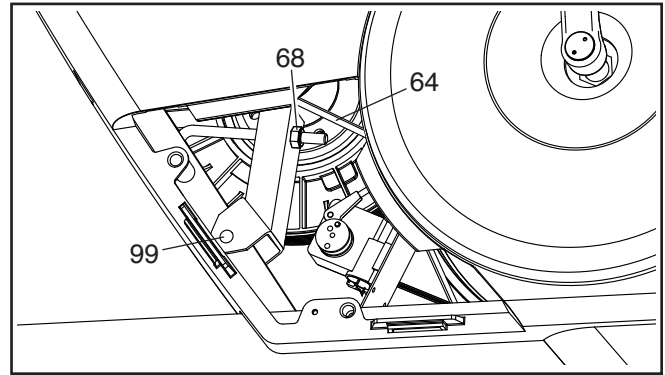

When the Drive Belt (64) is tight, tighten the M10 x 55mm Shoulder Bolt (99). Then, reattach the side access cover and plug in the power adapter.

EXERCISE GUIDELINES

⚠️ WARNING: Before beginning this or any exercise program, consult your physician. This is especially important for persons over age 35 or persons with pre-existing health problems.

These guidelines will help you to plan your exercise program. For detailed exercise information, obtain a reputable book or consult your physician. Remember, proper nutrition and adequate rest are essential for successful results.

EXERCISE INTENSITY

Whether your goal is to burn fat or to strengthen your cardiovascular system, exercising at the proper intensity is the key to achieving results. You can use your heart rate as a guide to find the proper intensity level. The chart below shows recommended heart rates for fat burning and aerobic exercise.

165	155	145	140	130	125	115	♥️
145	138	130	125	118	110	103	♥️
125	120	115	110	105	95	90	♥️
<hr/>							
20	30	40	50	60	70	80	

To find the proper intensity level, find your age at the bottom of the chart (ages are rounded off to the nearest ten years). The three numbers listed above your age define your “training zone.” The lowest number is the heart rate for fat burning, the middle number is the heart rate for maximum fat burning, and the highest number is the heart rate for aerobic exercise.

Burning Fat—To burn fat effectively, you must exercise at a low intensity level for a sustained period of time. During the first few minutes of exercise, your body uses carbohydrate calories for energy. Only after the first few minutes of exercise does your body begin to use stored fat calories for energy. If your goal is to burn fat, adjust the intensity of your exercise until your heart rate is near the lowest number in your training zone. For maximum fat burning, exercise with your heart rate near the middle number in your training zone.

Aerobic Exercise—If your goal is to strengthen your cardiovascular system, you must perform aerobic exercise, which is activity that requires large amounts of oxygen for prolonged periods of time. For aerobic exercise, adjust the intensity of your exercise until your heart rate is near the highest number in your training zone.

HOW TO MEASURE YOUR HEART RATE

To measure your heart rate, exercise for at least four minutes. Then, stop exercising and place two fingers on your wrist as shown. Take a six-second heartbeat count, and multiply the result by 10 to find your heart rate. For example, if your six-second heartbeat count is 14, your heart rate is 140 beats per minute.

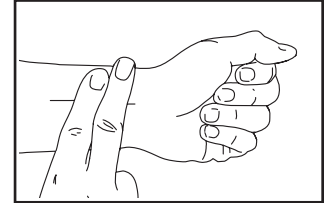

WORKOUT GUIDELINES

Warming Up—Start with 5 to 10 minutes of stretching and light exercise. A warm-up increases your body temperature, heart rate, and circulation in preparation for exercise.

Training Zone Exercise—Exercise for 20 to 30 minutes with your heart rate in your training zone. (During the first few weeks of your exercise program, do not keep your heart rate in your training zone for longer than 20 minutes.) Breathe regularly and deeply as you exercise; never hold your breath.

Cooling Down—Finish with 5 to 10 minutes of stretching. Stretching increases the flexibility of your muscles and helps to prevent post-exercise problems.

EXERCISE FREQUENCY

To maintain or improve your condition, complete three workouts each week, with at least one day of rest between workouts. After a few months of regular exercise, you may complete up to five workouts each week, if desired. Remember, the key to success is to make exercise a regular and enjoyable part of your everyday life.

PART LIST

Model No. PFEL03721C.0 R1121A

Key No.	Qty.	Description	Key No.	Qty.	Description
1	1	Frame	51	6	Crank Bearing
2	1	Upright	52	1	Bearing Spacer
3	1	Pivot Bracket	53	1	Crank Collar
4	1	Console	54	1	Idler Axle
5	1	Front Stabilizer	55	1	Idler Bolt
6	1	Rear Stabilizer	56	2	Idler Bushing
7	1	Right Upper Body Arm	57	1	Idler Bracket
8	1	Right Pivot Leg	58	1	Small Pulley
9	1	Right Pedal Arm	59	1	Flywheel
10	1	Left Upper Body Arm	60	1	Reed Switch/Wire
11	1	Left Pivot Leg	61	1	Seat Frame
12	1	Left Pedal Arm	62	2	Leveling Foot
13	1	Pivot Knob	63	1	Clamp
14	1	Accessory Tray	64	2	Drive Belt
15	2	Upper Body Grip	65	14	Pivot Bushing
16	2	Handgrip	66	1	Left Crank Bracket
17	2	Wheel Cap	67	1	Set Screw
18	3	Crank Screw Cap	68	20	M8 Locknut
19	4	M10 x 80mm Screw	69	3	Crank Screw
20	1	Wire Cover	70	1	Right Large Pedal
21	1	Side Access Cover	71	1	Left Large Pedal
22	1	Left Shield	72	2	Pedal Insert
23	1	Right Shield	73	2	Pedal Base
24	2	Crank Arm	74	1	Right Small Pedal
25	1	Pivot Cover	75	2	Upper Body Cap
26	1	Rear Access Cover	76	10	M10 x 20mm Screw
27	1	Backrest	77	1	M5 x 10mm Screw
28	1	Seat	78	2	Upper Body Cover
29	2	Seat Handlebar	79	2	Pivot Spacer
30	1	Right Crank Bracket	80	1	Pivot Axle
31	2	Seat Grip	81	2	Pivot Leg Cap
32	1	Seat Carriage	82	2	Wheel
33	2	Seat Handlebar Cap	83	6	Pivot Cover
34	1	Seat Carriage Bracket	84	37	M4 x 16mm Screw
35	2	Seat Carriage Bushing	85	4	Foot
36	1	Adjustment Pin	86	6	M8 x 14mm Shoulder Screw
37	1	Carriage Knob	87	7	M8 Washer
38	1	Carriage Knob Screw	88	2	M5 Nut
39	4	M6 x 10mm Bolt	89	2	M5 x 10mm Black Screw
40	12	M6 x 12mm Screw	90	5	M4 x 10mm Screw
41	2	Carriage Cap	91	2	M5 Washer
42	2	Stabilizer Cap	92	8	M8 x 20mm Bolt
43	1	C-magnet	93	2	Pulley Magnet
44	1	Resistance Motor	94	1	Upper Wire
45	1	Resistance Arm	95	4	M8 x 38mm Bolt
46	1	Resistance Disc	96	1	Main Wire
47	1	Resistance Block	97	4	M6 x 18mm Screw
48	2	Large Pulley	98	4	M6 x 35mm Screw
49	1	Crank	99	1	M10 x 55mm Shoulder Bolt
50	1	Weld Spacer	100	1	M8 Snap Ring

Key No.	Qty.	Description	Key No.	Qty.	Description
101	2	M10 x 54mm Shoulder Screw	112	2	Clip Nut
102	6	M8 x 38mm Hex Bolt	113	1	Left Pedal Brace
103	1	Receptacle/Wire	114	2	Pedal Weight
104	1	Power Adapter	115	2	Weight Screw
105	2	M19 Snap Ring	116	4	Pedal Brace Bushing
106	6	M8 x 12mm Screw	117	2	M10 x 20mm Shoulder Screw
107	1	Left Small Pedal	118	2	Pedal Axle
108	1	M4 x 16mm Bright Screw	119	2	M10 Washer
109	1	Right Pedal Brace	*	–	User's Manual
110	8	M8 Split Washer	*	–	Assembly Tool
111	4	M6 Locknut	*	–	Grease Packet

Note: Specifications are subject to change without notice. For information about ordering replacement parts, see the back cover of this manual. *These parts are not illustrated.

EXPLODED DRAWING A

Model No. PFEL03721C.0 R1121A

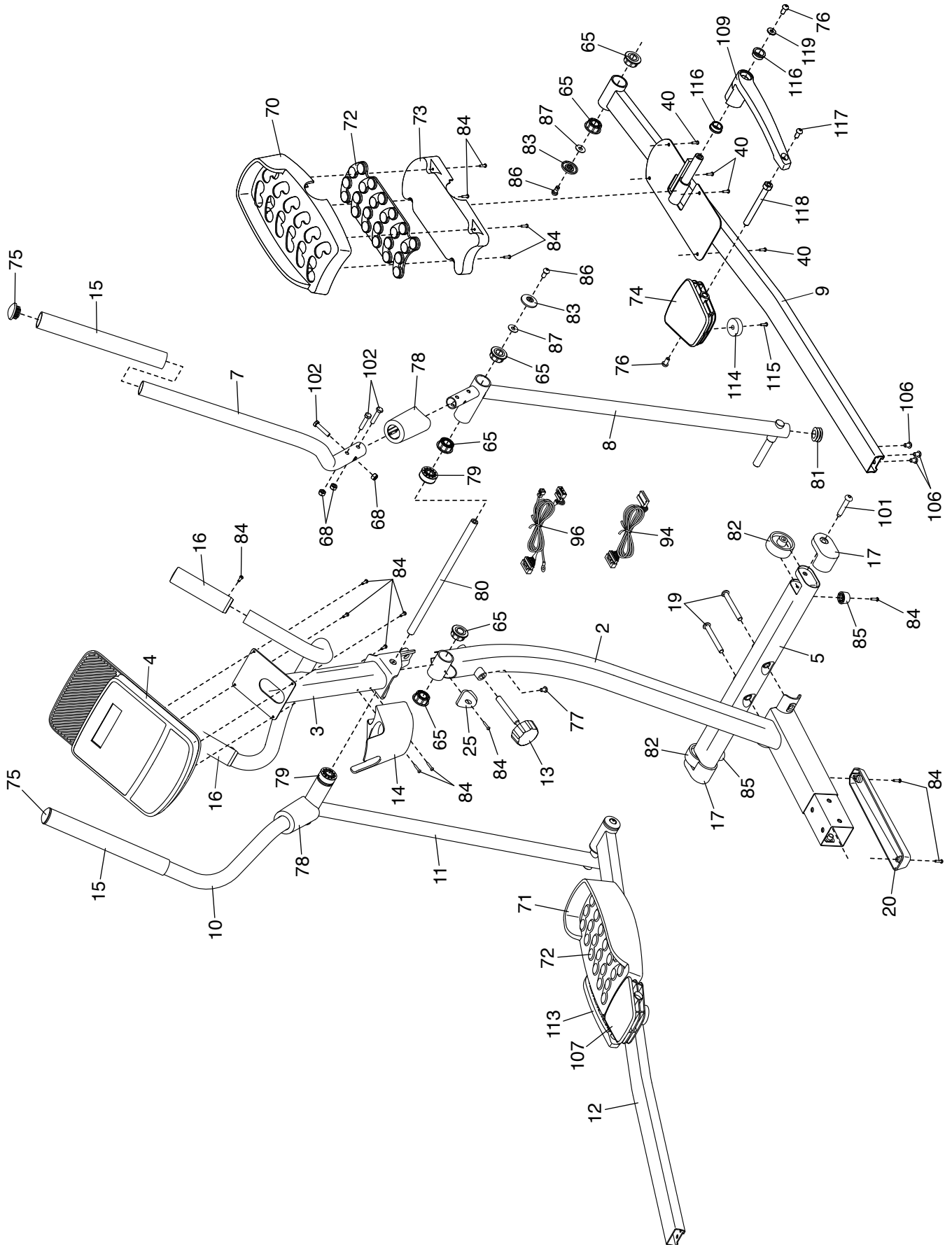

EXPLODED DRAWING B

Model No. PFEL03721C.0 R1121A

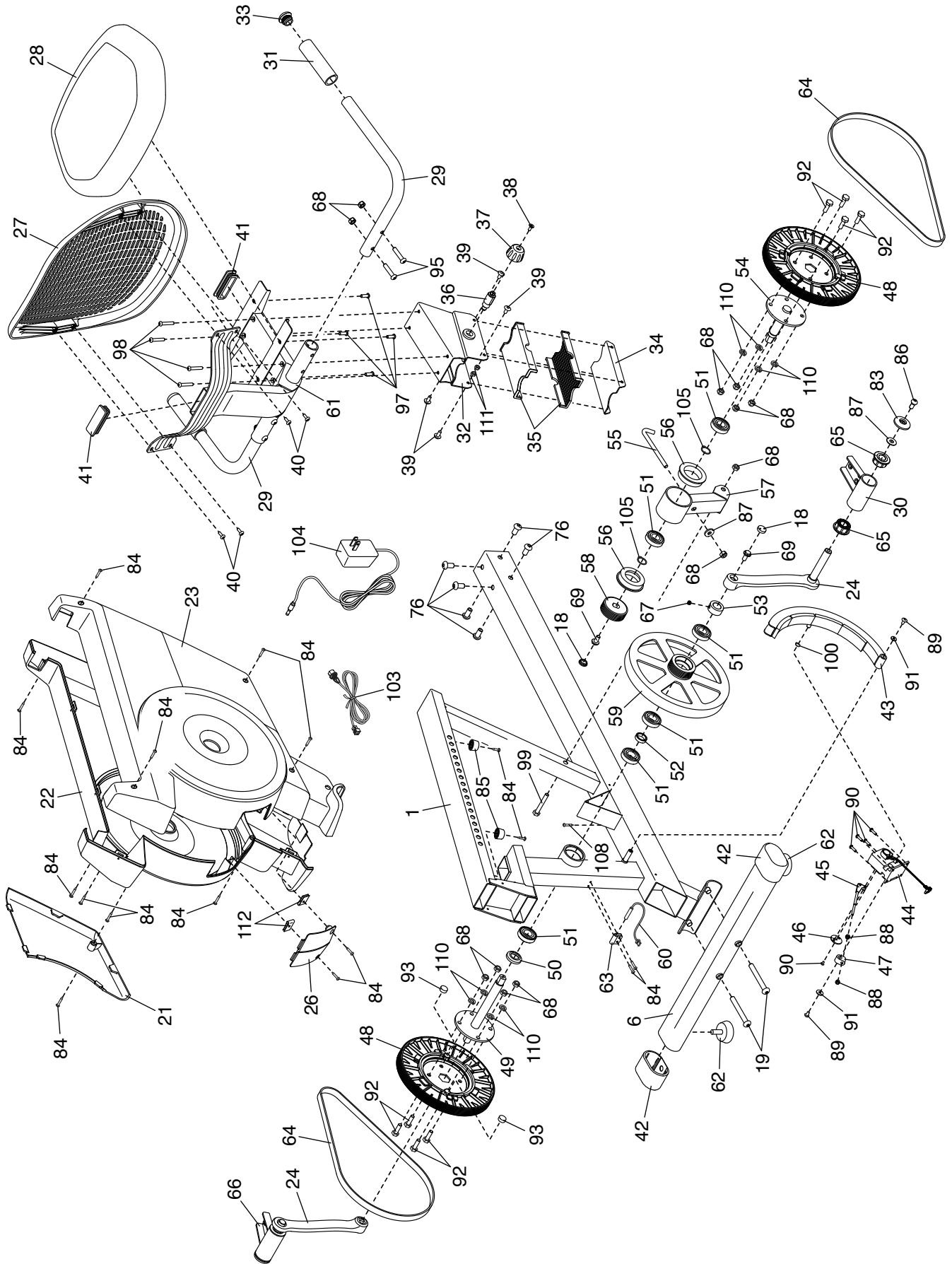

ORDERING REPLACEMENT PARTS

To order replacement parts, please see the front cover of this manual. To help us assist you, be prepared to provide the following information when contacting us:

- the model number and serial number of the product (see the front cover of this manual)
- the name of the product (see the front cover of this manual)
- the key number and description of the replacement part(s) (see the PART LIST and the EXPLODED DRAWING near the end of this manual)

LIMITED WARRANTY

IMPORTANT: To protect your fitness equipment with an extended service plan, see page 4.

iFIT Health & Fitness Inc. (iFIT) warrants this product to be free from defects in workmanship and material, under normal use and service conditions. The frame is warranted for five (5) years from the date of purchase. Parts and labor are warranted for one (1) year from the date of purchase.

This warranty extends only to the original purchaser (customer) and is not transferrable. iFIT's obligation under this warranty is limited to repairing or replacing, at iFIT's discretion, the product through one of its authorized service providers. All repairs for which warranty claims are made must be preauthorized by iFIT. If replacement parts are shipped while the product is under warranty, the customer will be responsible for a minimal handling charge. For in-home service, the customer may be responsible for a minimal trip charge. This warranty does not extend to freight damage to the product. This warranty will automatically be voided by the following conditions: (1) if the product is used as a store display model, (2) if the product is purchased or transported outside of Canada, (3) if any instruction or warning in this manual is not followed, (4) if the product is abused or improperly or abnormally used, (5) if the product is modified to alter functionality or capability without the written permission of iFIT, or (6) if the product is used for commercial or rental purposes. No other warranty beyond that specifically set forth above is authorized by iFIT.

iFIT is not responsible or liable for the following damages: (1) indirect, special, or consequential damages arising out of or in connection with the use or performance of the product; (2) damages with respect to any economic loss, loss of property, loss of revenues or profits, loss of enjoyment or use, or costs of removal or installation; or (3) other consequential damages of any kind. Some provinces do not allow the exclusion or limitation of incidental or consequential damages. Accordingly, the above limitation may not apply to the customer.

The warranty extended hereunder is in lieu of any and all other warranties, and any implied warranties of merchantability or fitness for a particular purpose are limited in their scope and duration to the terms set forth herein. Some provinces do not allow limitations on how long an implied warranty lasts. Accordingly, the above limitation may not apply to the customer. This warranty provides specific legal rights; the customer may have other rights that vary from province to province.

For warranty service, please call the telephone number on the front cover of this manual. Please be prepared to provide the model number and serial number of the product (see the front cover of this manual).

iFIT Health & Fitness Inc., 900 de l'Industrie, St. Jérôme, QC J7Y 4B8