

PRO-FORM[®]

CC500

proformfitness.ca

Model No. PFTL39621C.0

Serial No. _____

Write the serial number in the space above for reference.

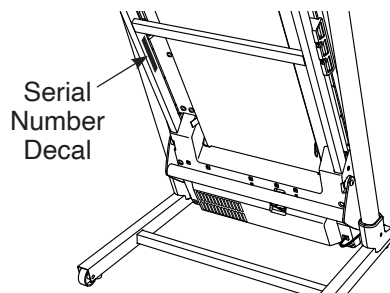

REGISTER YOUR PRODUCT

To register your product and activate your warranty today, go to iconservice.ca.

MEMBER CARE

Call toll-free 1-888-936-4266
Mon.–Fri. 7:30 a.m.–4:30 p.m. ET
(excluding holidays)

or email us at
customerservice@iconcanada.ca

Please do not contact the store.

CAUTION

Read all precautions and instructions in this manual before using this equipment. Save this manual for future reference.

USER'S MANUAL

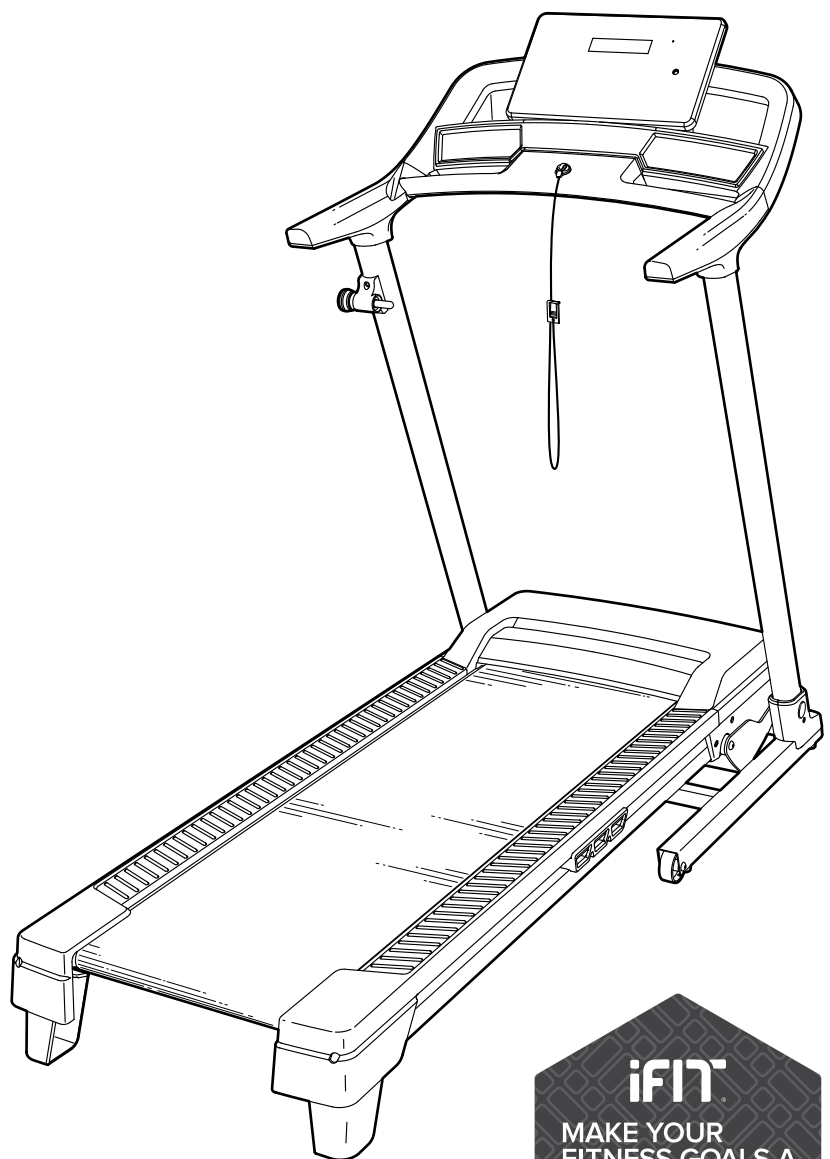

TABLE OF CONTENTS

WARNING DECAL PLACEMENT 2

IMPORTANT PRECAUTIONS 3

BEFORE YOU BEGIN 6

PART IDENTIFICATION CHART 7

ASSEMBLY 8

HOW TO USE THE TREADMILL 13

IC INFORMATION 21

HOW TO FOLD AND MOVE THE TREADMILL 22

MAINTENANCE AND TROUBLESHOOTING 23

EXERCISE GUIDELINES 25

PART LIST 26

EXPLODED DRAWING 28

ORDERING REPLACEMENT PARTS Back Cover

LIMITED WARRANTY Back Cover

WARNING DECAL PLACEMENT

This drawing shows the location(s) of the warning decal(s). **If a decal is missing or illegible, see the front cover of this manual and request a free replacement decal. Apply the decal in the location shown.** Note: The decal(s) may not be shown at actual size.

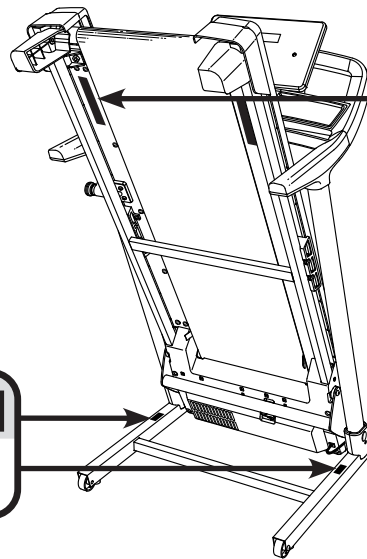



CAUTION

KEEP HANDS AND FEET AWAY FROM THIS AREA WHILE THE TREADMILL IS IN OPERATION.



ATTENTION

GARDEZ VOS PIEDS ET VOS MAINS ÉLOIGNÉS DE CET ENDROIT QUAND LE TAPIS ROULANT EST EN MARCHÉ.

▲ WARNING:

Protect yourself and others from risk of serious injury. Read the user's manual, and:

-  • Stand only on the side rails when starting or stopping treadmill.
- Change speed in small increments.
- Hold handrails to prevent falling, and always wear the safety clip while operating the treadmill.
- Stop if you feel faint, dizzy, or short of breath.
- Fully engage the storage latch before the treadmill is moved or stored.
- Incline should be set to zero before folding the treadmill into a storage position.
- Never allow children on or around the treadmill.
- Remove the safety key when treadmill is not in use.
- Keep clothing, fingers, and hair away from moving parts.
- Never try to adjust or fix the belt while it is moving.
- Always wear athletic shoes while operating the treadmill.

PROFORM and iFIT are registered trademarks of ICON Health & Fitness, Inc. App Store is a trademark of Apple Inc., registered in the U.S. and other countries. Android and Google Play are trademarks of Google LLC. The Bluetooth® word mark and logos are registered trademarks of Bluetooth SIG, Inc. and are used under license. IOS is a trademark or registered trademark of Cisco in the U.S. and other countries and is used under license.

IMPORTANT PRECAUTIONS

⚠️ WARNING: To reduce the risk of burns, fire, electric shock, or injury to persons, read all important precautions and instructions in this manual and all warnings on the treadmill before using the treadmill. ICON assumes no responsibility for personal injury or property damage sustained by or through the use of this product.

1. It is the responsibility of the owner to ensure that all users of the treadmill are adequately informed of all warnings and precautions.
2. Keep children under age 16 and pets away from the treadmill at all times.
3. Consult your health care provider before beginning any exercise program. This is especially important for persons over age 35 or persons with pre-existing health problems.
4. Consult your health care provider before beginning or continuing any exercise program during pregnancy. Use the treadmill only as authorized by your health care provider.
5. The treadmill is not intended for use by persons with reduced physical, sensory, or mental capabilities or lack of experience and knowledge, unless they have been given supervision or instruction concerning use of the treadmill by someone responsible for their safety.
6. Use the treadmill only as described in this manual.
7. The treadmill is intended for home use only. Do not use the treadmill in any commercial, rental, or institutional setting.
8. Keep the treadmill indoors, away from moisture and dust. Do not put the treadmill in a garage or covered patio, or near water.
9. Place the treadmill on a level surface, with at least 8 ft. (2.4 m) of clearance behind it and 2 ft. (0.6 m) on each side. Do not place the treadmill on any surface that blocks air openings. To protect the floor or carpet from damage, place a mat under the treadmill.
10. Do not operate the treadmill where aerosol products are used or where oxygen is being administered.
11. The treadmill should be used only by persons weighing 300 lbs. (136 kg) or less.
12. Never allow more than one person on the treadmill at a time.
13. Wear appropriate exercise clothes while using the treadmill. Do not wear loose clothes that could become caught in the treadmill. Athletic support clothes are recommended for both men and women. *Always wear athletic shoes. Never use the treadmill with bare feet, wearing only stockings, or in sandals.*
14. Plug the power cord into a surge suppressor (not included), and plug the surge suppressor into an appropriate outlet (see page 13). To avoid overloading the circuit, do not plug other electrical devices, except for low-power devices such as cell phone chargers, into the surge suppressor or into an outlet on the same circuit.
15. Use only a surge suppressor that meets all of the specifications described on page 13. To purchase a surge suppressor, see your local PROFORM dealer, call the telephone number on the front cover of this manual, or see your local electronics store.
16. Failure to use a properly functioning surge suppressor could result in damage to the control system of the treadmill. If the control system is damaged, the walking belt may slow, accelerate, or stop unexpectedly, which may result in a fall and serious injury.
17. Keep the power cord and the surge suppressor away from heated surfaces.
18. Never move the walking belt while the power is turned off. Do not operate the treadmill if the power cord or plug is damaged, or if the treadmill is not working properly. (See MAINTENANCE AND TROUBLESHOOTING on page 23 if the treadmill is not working properly.)

19. Read, understand, and test the emergency stop procedure before using the treadmill (see HOW TO TURN ON THE POWER on page 15). Always wear the clip while using the treadmill.
20. Be careful when mounting and dismounting the treadmill. Always stand on the foot rails when starting or stopping the walking belt. Always hold the handrails while using the treadmill.
21. When a person is walking on the treadmill, the noise level of the treadmill will increase.
22. Keep fingers, hair, and clothing away from the moving walking belt.
23. The treadmill is capable of high speeds. Adjust the speed in small increments to avoid sudden jumps in speed.
24. Never leave the treadmill unattended while it is running. Always remove the key, press the power switch into the off position (see the drawing on page 6 for the location of the power switch), and unplug the power cord when the treadmill is not in use.
25. Do not attempt to move the treadmill until it is properly assembled. (See ASSEMBLY on page 8 and HOW TO FOLD AND MOVE THE TREADMILL on page 22.) You must be able to safely lift 45 lbs. (20 kg) to move the treadmill.
26. When folding or moving the treadmill, make sure that the storage latch is holding the frame securely in the storage position. Do not operate the treadmill while it is folded.
27. Do not change the incline of the treadmill by placing objects under the treadmill.
28. Never insert any object into any opening on the treadmill.
29. Inspect and properly tighten all parts each time the treadmill is used. Replace any worn parts immediately. Use only manufacturer-supplied parts.
30. **DANGER:** Always unplug the power cord immediately after use, before cleaning the treadmill, and before performing the maintenance and adjustment procedures described in this manual. Never remove the motor hood unless instructed to do so by an authorized service representative. Servicing other than the procedures in this manual should be performed by an authorized service representative only.
31. Over exercising may result in serious injury or death. If you feel faint, if you become short of breath, or if you experience pain while exercising, stop immediately and cool down.

SAVE THESE INSTRUCTIONS

PROTECT

YOUR FITNESS EQUIPMENT
WITH AN EXTENDED SERVICE PLAN



Your new fitness equipment represents a significant investment in your health. Protect your investment now from unexpected mechanical or electrical failures for up to five years.

PLAN FEATURES

- Protection for one to five years
- Over 100 authorized repair centers
- Highly trained repair technicians
- A national toll-free repair hotline
- Simple repair claim procedure
- No claim forms
- Easy enrollment
- Service available within 100 miles (161 km) of nearest authorized repair center
- In-home repairs covered
- Parts and labour covered
- Mechanical and electrical failures covered

To protect your fitness equipment today, please
call Customer Service at **1-888-936-4266**
Or, email us at customerservice@iconcanada.ca

 **ICON**[™]
du/of Canada Inc.

BEFORE YOU BEGIN

Thank you for selecting the new PROFORM® CC500 treadmill. The CC500 treadmill offers a selection of features designed to make your workouts at home more effective. And when you're not exercising, the treadmill can be folded up, requiring less than half the floor space of other treadmills.

For your benefit, read this manual carefully before using the treadmill. If you have questions after

reading this manual, please see the front cover of this manual. To help us assist you, note the product model number and serial number before contacting us. The model number and the location of the serial number decal are shown on the front cover of this manual.

Before reading further, please review the drawing below and familiarize yourself with the labeled parts.

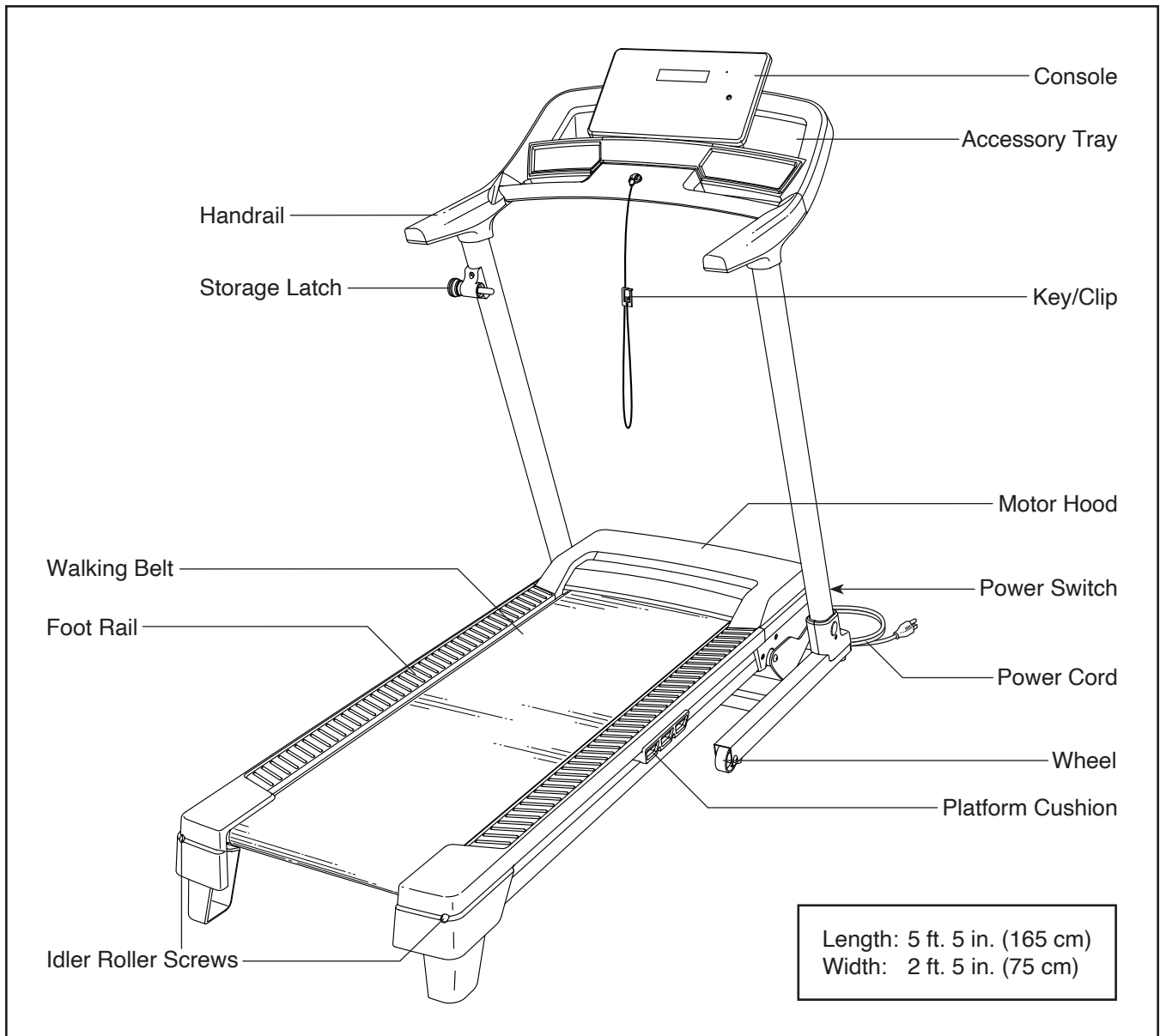

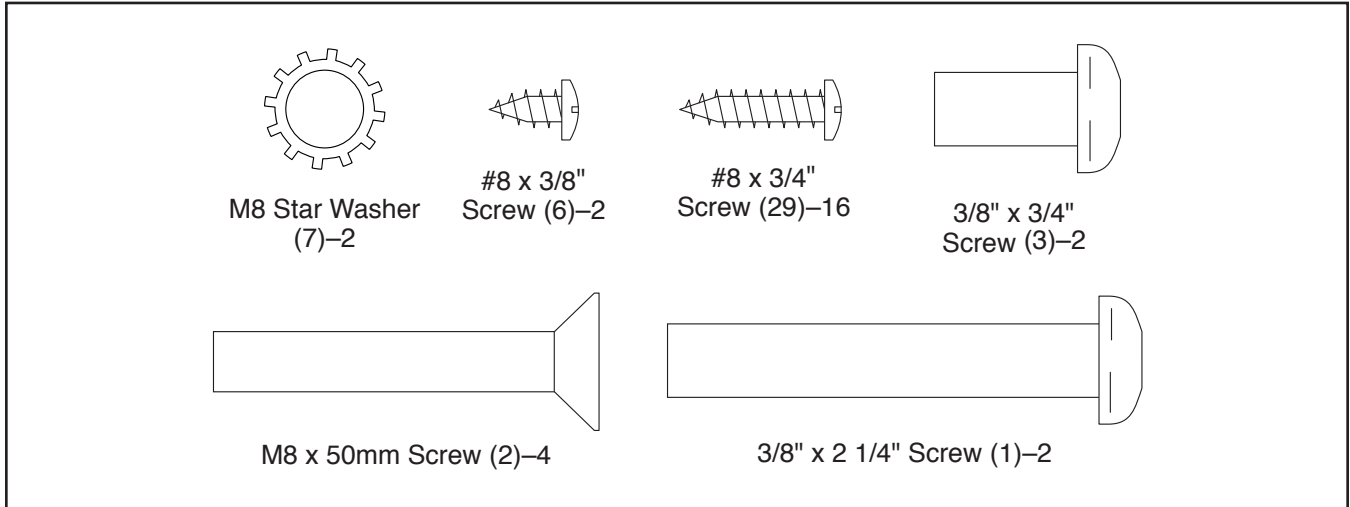

PART IDENTIFICATION CHART

Use the drawings below to identify small parts used for assembly. The number in parentheses below each drawing is the key number of the part, from the PART LIST near the end of this manual. The number following the key number is the quantity used for assembly. **Note: If a part is not in the hardware kit, check to see whether it is preattached. Extra parts may be included.**



ASSEMBLY

- Assembly requires two persons.
 - Place all parts in a cleared area and remove the packing materials. Do not dispose of the packing materials until you finish all assembly steps.
 - After shipping, there may be an oily substance on the exterior of the treadmill. This is normal. If there is an oily substance on the treadmill, wipe it off with a soft cloth and a mild, non-abrasive cleaner.
 - To identify small parts, see page 7.
 - Left parts are marked “L” or “Left” and right parts are marked “R” or “Right.”
 - Assembly requires the following tools:
 - the included hex keys 
 - one Phillips screwdriver 
- To avoid damaging parts, do not use power tools.

1. **Go to iconservice.ca/CustomerService/registration and register your product.**

- documents your ownership
- activates your warranty
- ensures priority customer support if assistance is ever needed

Note: If you do not have internet access, call Member Care (see the front cover of this manual) and register your product.

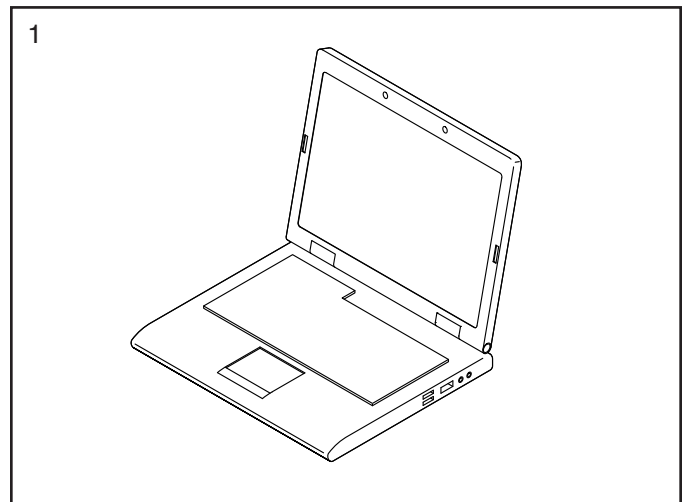

2. **Make sure that the power cord is unplugged.**

Carefully raise the Right Upright (81) to the vertical position.

Next, start a 3/8" x 2 1/4" Screw (1) and a 3/8" x 3/4" Screw (3) into the Right Upright (81) and the Base (90) as shown; **then, tighten both Screws.**

Repeat this step on the left side of the treadmill.

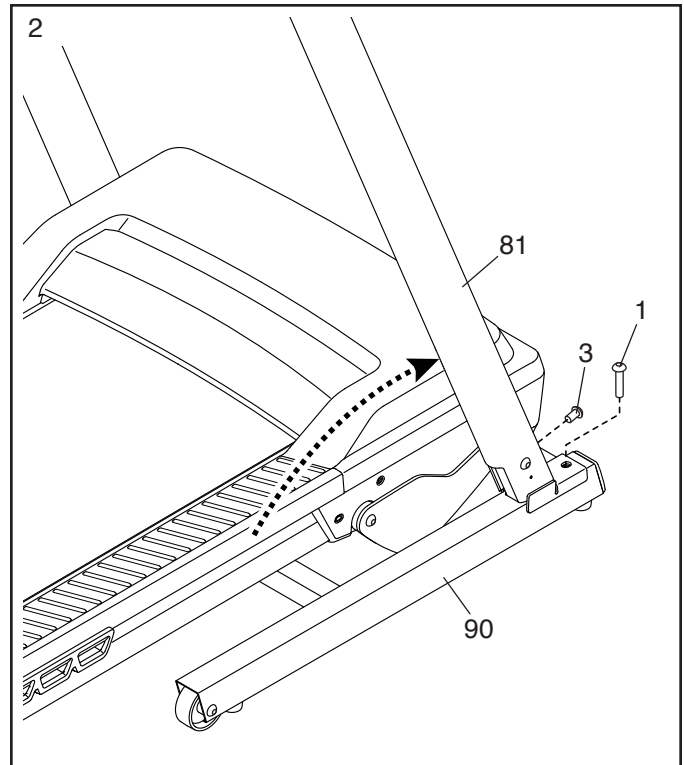

3. Identify the Left and Right Handrail Bottoms (73, 74), and slide them onto the Uprights (80, 81) as shown.

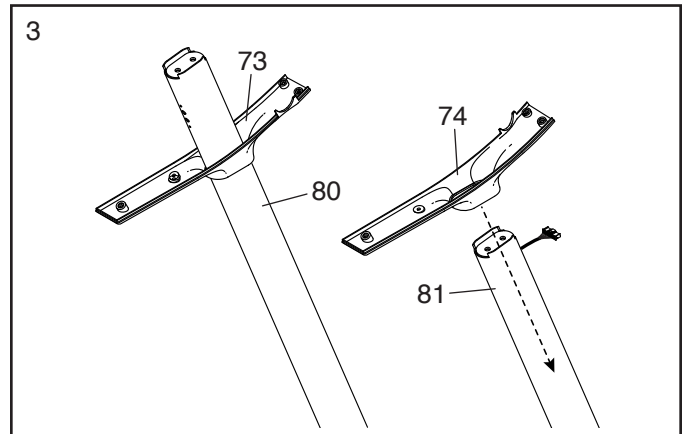

4. Set the console assembly (A) face down on a soft surface to avoid scratching the console assembly.

Attach the Right and Left Trays (95, 94) with six #8 x 3/4" Screws (29); **start all six Screws, and then tighten them. Do not overtighten the Screws.**

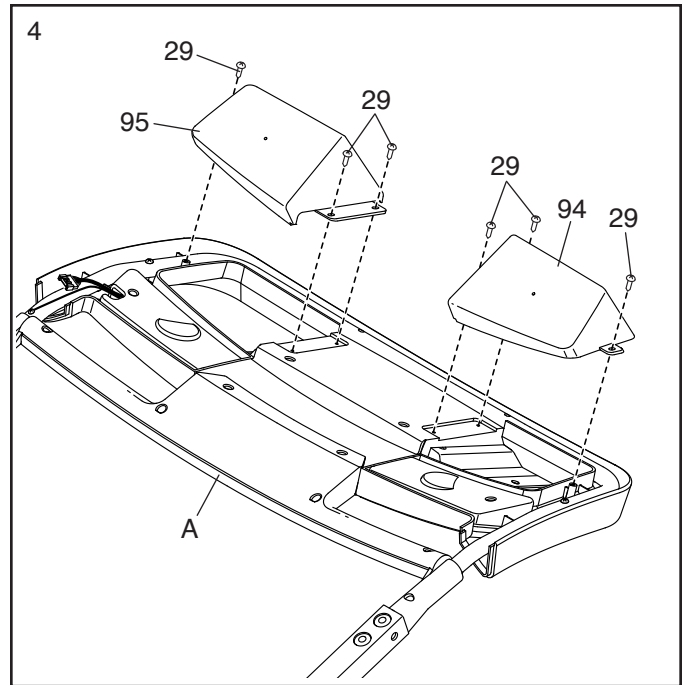

5. With the help of a second person, set the console assembly (A) on the Uprights (80, 81). Attach the console assembly with four M8 x 50mm Screws (2) and two M8 Star Washers (7); **start all four Screws, and then tighten them.**

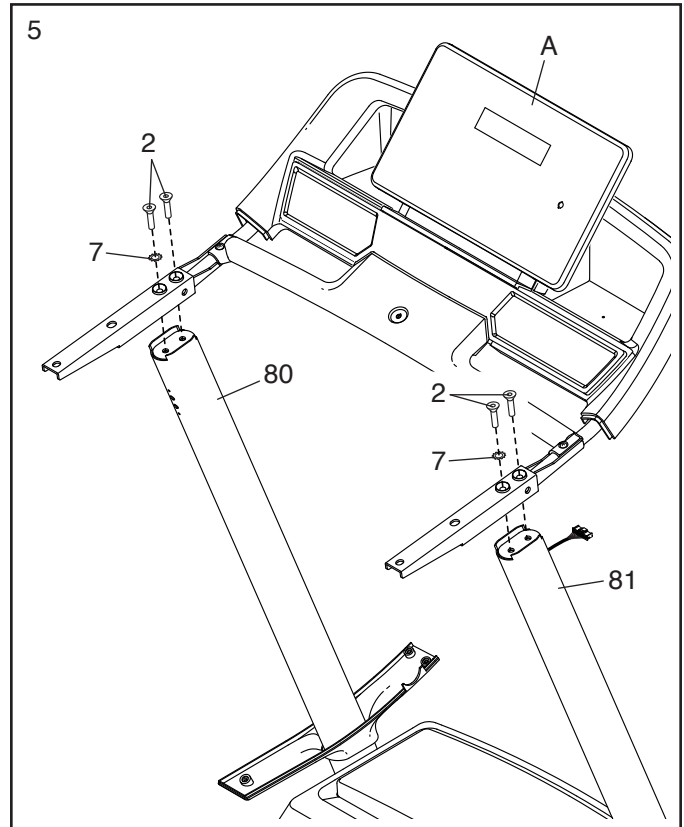

6. Connect the Upright Wire (78) to the console wire (B). **The connectors should slide together easily and snap into place with an audible click. If they do not, turn one connector and try again.**

Insert any excess wire into the console assembly (A).

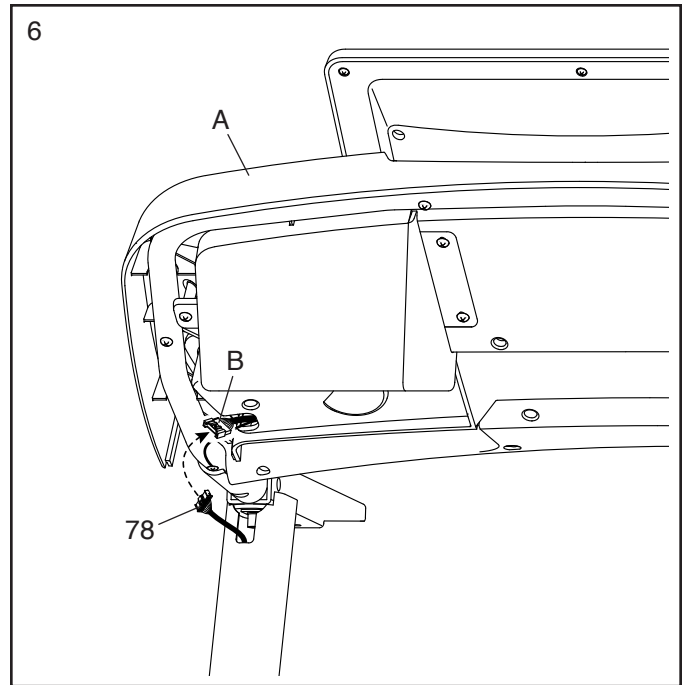

7. Identify the Right Handrail Top (72). Set the Right Handrail Top on the Handrail (76), and slide it forward against the console assembly (A).

Next, slide the Right Handrail Bottom (74) upward. **Make sure that the Upright Wire (78) is covered by the Right Handrail Bottom and is not pinched.** Attach the Right Handrail Bottom with four #8 x 3/4" Screws (29); **start all four Screws, then tighten them. Note: The Screws need to be inserted at an angle as shown. Be careful not to overtighten the Screws.**

Attach the Left Handrail Top (not shown) and the Left Handrail Bottom (not shown) as described above. Note: There are no wires on the left side.

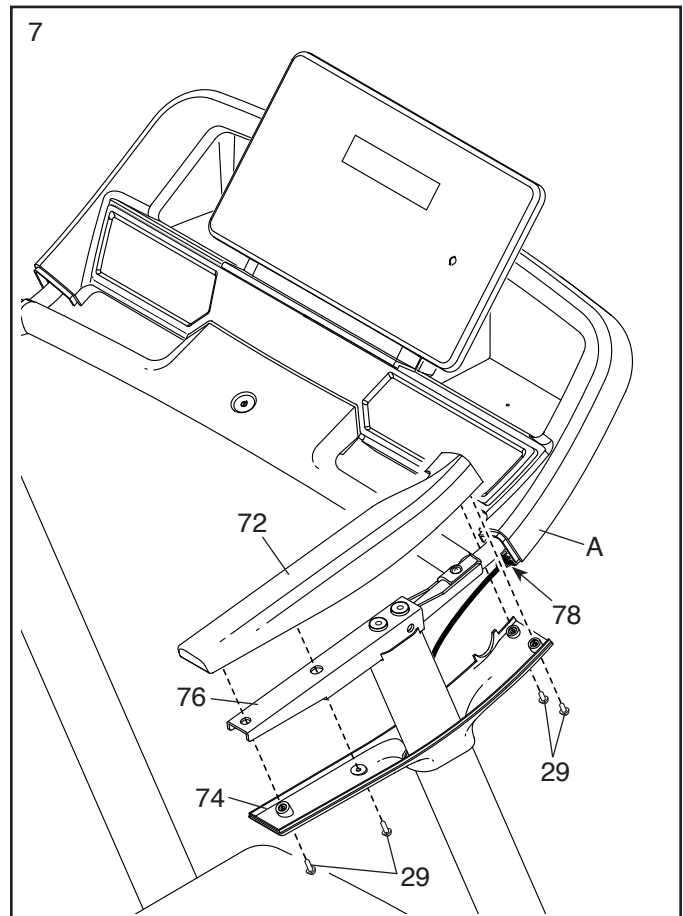

- Slide the Right Inner Upright Cover (84) between the Right Upright (81) and the Motor Hood (62). Next, press the Right Outer Upright Cover (85) against the Right Inner Upright Cover until they snap together.

Then, tighten a #8 x 3/8" Screw (6) into the Right Outer Upright Cover (85). **Do not overtighten the Screw.**

Repeat this step on the left side of the treadmill.

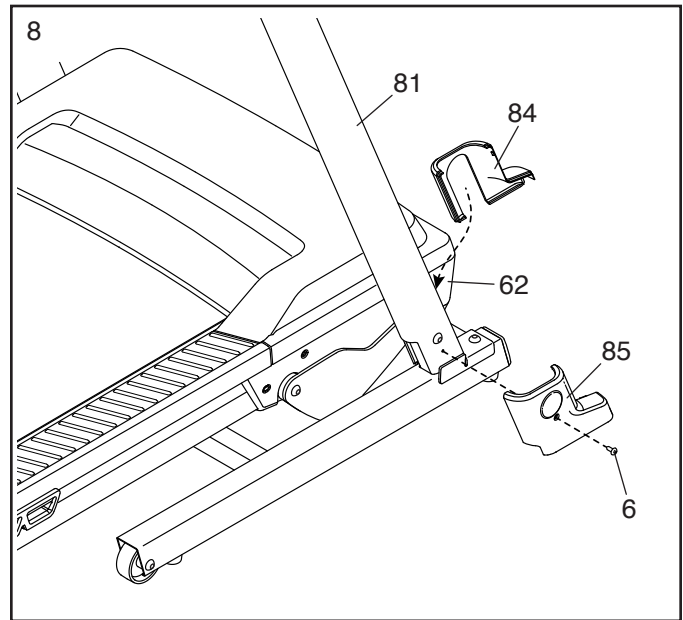

- Orient the Storage Latch (79) as shown. Attach the Storage Latch to the Left Upright (80) with two #8 x 3/4" Screws (29); **start both Screws, and then tighten them.**

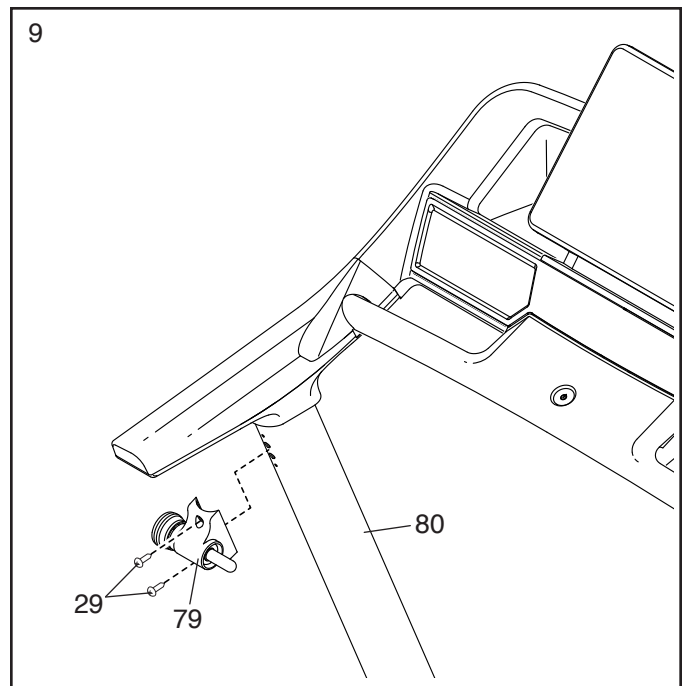

- Make sure that all parts are properly tightened before you use the treadmill.** To protect the floor or carpet, place a mat under the treadmill. To avoid damage to the console, keep the treadmill out of direct sunlight. Keep the included hex keys in a secure place. One of the hex keys is used to adjust the walking belt (see page 24). Note: Extra parts may be included.

HOW TO USE THE TREADMILL

HOW TO CONNECT THE POWER CORD

Use a Surge Suppressor

Your treadmill, like other electronic equipment, can be damaged by sudden voltage changes in your home's power. Voltage surges, spikes, and noise interference can result from weather conditions or from other appliances being turned on or off. **To decrease the risk of damaging the treadmill, always use a surge suppressor (A) with the treadmill. To purchase a surge suppressor, see precaution 14 on page 3.**

Use only a surge suppressor (A) that is UL 1449 listed as a transient voltage surge suppressor (TVSS). The surge suppressor must have a UL suppressed voltage rating of 400 volts or less and a minimum surge dissipation of 450 joules. The surge suppressor must also be electrically rated for 120 volts AC and 15 amps. There must be a monitoring light on the surge suppressor to indicate whether it is functioning properly. **Failure to use a properly functioning surge suppressor could result in damage to the control system of the treadmill and serious injury to users.**

Plug in the Power Cord

The treadmill must be grounded. If it should malfunction or break down, grounding provides a path of least resistance for electric current to reduce the risk of electric shock. The treadmill power cord (B) has a plug with a grounding pin (C) (see drawing 1 on this page).

⚠ DANGER: Improper connection of the power cord increases the risk of electric shock. Do not modify the plug—if it will not fit an outlet, have a proper outlet installed by a qualified electrician. If you are unsure whether the treadmill is properly grounded, contact a qualified electrician.

Plug the power cord (B) into a surge suppressor (A), and plug the surge suppressor into an appropriate outlet (D) that is properly installed and grounded in accordance with all local codes and ordinances. **The outlet must be on a nominal 120-volt circuit**

capable of carrying 15 or more amps. To avoid overloading the circuit, do not plug other electrical devices, except for low-power devices such as cell phone chargers, into the surge suppressor or into an outlet on the same circuit. **IMPORTANT: If the treadmill is connected to an AFCI-equipped outlet and your circuit breaker trips repeatedly when the treadmill is used, see the front cover of this manual to purchase an arc filter.**

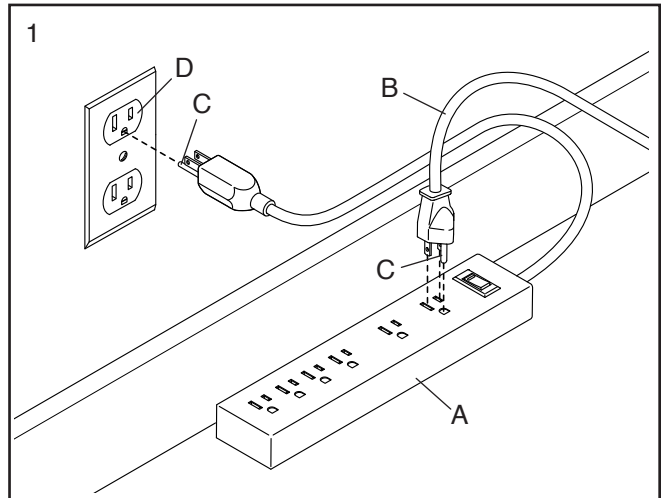

A temporary adapter (E) may be used to connect the surge suppressor (A) to a 2-pole receptacle (F) if a properly grounded outlet is not available.

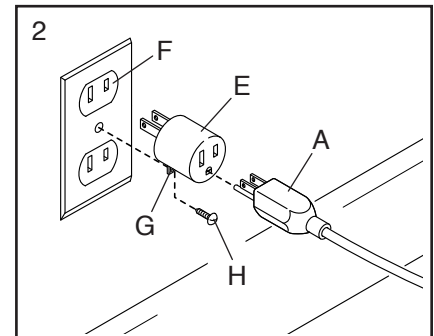

The lug (G) or wire extending from the adapter must be connected with a metal screw (H) to a permanent ground such as a properly grounded outlet box cover. **Some 2-pole receptacle outlet box covers are not grounded. Before using an adapter, contact a qualified electrician to determine whether the outlet box cover is grounded. The temporary adapter should be used only until a properly grounded outlet can be installed by a qualified electrician.**

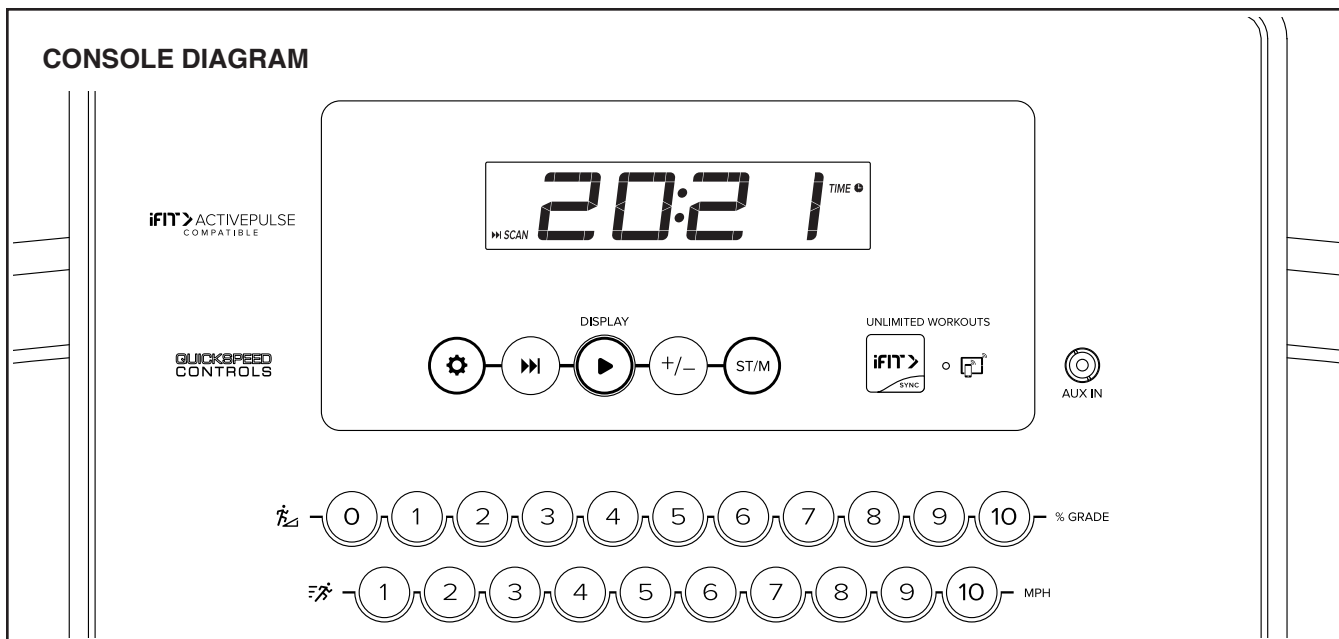

FEATURES OF THE CONSOLE

The treadmill console offers a selection of features designed to make your workouts more effective and enjoyable. During your workouts, you can change the speed and incline of the treadmill with the touch of a button. As you exercise, the console will display continuous exercise feedback. You can even monitor your heart rate using a compatible heart rate monitor. **See page 20 for information about purchasing a compatible heart rate monitor.**

With an iFIT subscription, you can also connect your tablet to the console and use the iFIT app to access iFIT's unrivaled selection of studio and destination workouts. You can even set fitness goals and record your workouts to track your progress.

You can even listen to your favorite workout music or audio books with the console's sound system while you exercise.

To turn on the power, see page 15. To use the manual mode, see page 15. To use an iFIT workout, see page 17. To connect a heart rate monitor to the console, see page 19. To use the settings mode, see page 19. To use the sound system, see page 20.

IMPORTANT: If there is a sheet of plastic on the console, remove the plastic. To prevent damage to the walking platform, wear clean athletic shoes while using the treadmill. The first time the treadmill is used, observe the alignment of the walking belt, and center the walking belt if necessary (see page 24).

Note: The console can display speed and distance in either miles or kilometers. To find which unit of measurement is selected, see THE SETTINGS MODE on page 19. To change the unit of measurement, press the St/M button. For simplicity, all instructions in this section refer to miles.

HOW TO TURN ON THE POWER

IMPORTANT: If the treadmill has been exposed to cold temperatures, allow it to warm to room temperature before you turn on the power. If you do not do this, you may damage the console displays or other electrical components.

Plug in the power cord (see page 13). Next, locate the power switch on the treadmill frame near the power cord. Make sure that the switch is in the reset position (I).

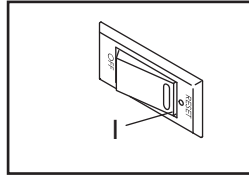

IMPORTANT: The console may feature a display demo mode, designed to be used if the treadmill is displayed in a store. If the display lights as soon as you plug in the power cord and press the power switch into the reset position, the demo mode is turned on. To turn off the demo mode, hold down the Stop button for a few seconds. If the display remains lit, see THE SETTINGS MODE on page 19 to turn off the demo mode.

Next, stand on the foot rails of the treadmill. Find the clip (J) attached to the key (K), and slide the clip onto the waistband of your clothes. Then, insert the key into the console. After a moment, the displays will light. **IMPORTANT:** In an emergency, the key can be pulled from the console, causing the walking belt to slow to a stop. Test the clip by carefully taking a few steps backward; if the key is not pulled from the console, adjust the position of the clip.

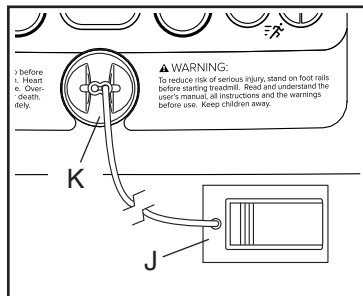

IMPORTANT: The first time you use the treadmill, you must calibrate the incline system (see step 3 on page 19).

HOW TO USE THE MANUAL MODE

1. Insert the key into the console.

See HOW TO TURN ON THE POWER at the left.

2. Start the walking belt.

To start the walking belt, press the Start button or one of the numbered speed buttons.

If you press the Start button, the walking belt will begin to move at 1 mph. As you exercise, change the speed of the walking belt as desired by pressing the Speed increase and decrease buttons. Each time you press one of the buttons, the speed setting will change by 0.1 mph; if you hold down the button, the speed setting will change in increments of 0.5 mph.

If you press one of the numbered speed buttons, the walking belt will gradually change speed until it reaches the selected speed setting. To select a speed setting that includes a decimal—such as 3.5 mph—press two numbered buttons in succession. For example, to select a speed setting of 3.5 mph, press the 3 button and then immediately press the 5 button. Note: This feature will not function when the console is set to metric units.

To stop the walking belt, press the Stop button. The time will begin to flash in the display. To restart the walking belt, press the Start button, the Speed increase button, or one of the numbered speed buttons.

3. Change the incline of the treadmill as desired.

To change the incline of the treadmill, press the Incline increase and decrease buttons or one of the numbered incline buttons. Each time you press the Incline increase or decrease button, the incline setting will change by 0.5 percent. If you press one of the numbered incline buttons, the incline will gradually change until it reaches the selected incline setting.

4. Follow your progress with the display.

The display can show the following workout information:

Calories (CALs)—The approximate number of calories you have burned.

Calories per Hour (CALs/HR)—The approximate number of calories you are burning per hour.

Distance (MI or KM)—The distance that you have walked or run in miles or kilometers. To change the unit of measurement, press the St/M button.

Incline (%Grade)—The incline level of the treadmill.

Pace—Your speed in minutes per mile or minutes per kilometer. To change the unit of measurement, press the St/M button.

Pulse (BPM and heart symbol)—Your heart rate when you use a compatible heart rate monitor (see page 20).

Speed (MPH or KPH)—Your speed in miles per hour or kilometers per hour. To change the unit of measurement, press the St/M button.

Time—The elapsed time.



Vertical Distance (VRT FT or VRT M)—The distance you have walked or run in vertical feet or vertical meters.

Press the Display button (L) repeatedly to view the desired workout information in the display.

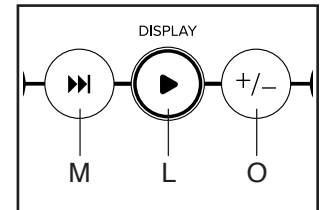

Scan mode—The console also has a scan mode that will display workout information in a repeating cycle. **To turn on the scan mode**, press the Scan button (M); the scan indicator (N) will turn on in the display.

To manually advance the scan cycle, press the Scan button repeatedly.

To turn off the scan mode, press the Display button; the scan indicator and the word SCAN will turn off.

You can also customize the scan mode to display only the desired workout information in the repeating cycle.

To customize the scan mode, first press the Display button repeatedly until the workout information that you want to add to or remove from the scan cycle appears in the display.

Next, press the Add/Remove button (O) to add or remove that workout information from the scan cycle. **When workout information is added**, its indicator will turn on in the display. **When workout information is removed**, its indicator will turn off.

Then, press the Scan button to turn on the scan mode.

To reset the displays, press the Stop button twice, remove the key, and then reinsert the key.

5. When you are finished exercising, remove the key from the console.

Step onto the foot rails, press the Stop button, and **adjust the incline of the treadmill to zero. The incline must be at zero when you fold the treadmill to the storage position, or you may damage the treadmill.** Next, remove the key from the console and put it in a secure place.

When you are finished using the treadmill, press the power switch into the off position and unplug the power cord. **IMPORTANT: If you do not do this, the treadmill's electrical components may wear prematurely.**

HOW TO USE AN iFIT WORKOUT

The console offers access to a large and varied library of iFIT workouts when you download the iFIT app to your smart device and connect it to the console.

Note: The console supports Bluetooth connections to smart devices via the iFIT app and to compatible heart rate monitors. Other Bluetooth connections are not supported.

1. Download and install the iFIT app on your smart device.

On your iOS® or Android™ smart device, open the App StoreSM or the Google Play™ store, search for the free iFIT app, and then install the app on your smart device. **Make sure that the Bluetooth option is enabled on your smart device.**

Then, open the iFIT app and follow the instructions to set up an iFIT account and customize settings.

Take time to explore the iFIT app and learn about its features and settings.

2. Connect your heart rate monitor to the console if desired.

If you are connecting both your heart rate monitor and your smart device to the console, **you must connect your heart rate monitor before you connect your smart device.** See HOW TO CONNECT A HEART RATE MONITOR TO THE CONSOLE on page 19.

3. Connect your smart device to the console.

Press the iFIT Sync button on the console; the console pairing number will appear in the display. Then, follow the instructions in the iFIT app to connect your smart device to the console.

When a connection is established, the LED on the console will turn solid blue.

4. Select an iFIT workout.

In the iFIT app, touch the buttons at the bottom of the screen to select either the main menu (Home button) or the workout library (Browse button).

To select a workout from the main menu or the workout library, simply touch the desired workout button on the screen. Slide or flick the screen to scroll upward or downward if necessary.

When you select a workout, the screen will show an overview of the workout that includes details such as the duration and distance of the workout and the approximate number of calories you will burn during the workout.

5. Start the workout.

Touch *Start Workout* to start the workout.

During some workouts, an iFIT coach will guide you through a video workout. Touch the sound button (music notes symbol) to select music, trainer voice, and volume options for the workout.

During some workouts, the screen will show a map of the route and a marker indicating your progress. Touch the buttons on the screen to select the desired map options.

If the speed or incline setting for the current segment of the workout is too high or too low, you can manually override the setting by pressing the Speed and Incline buttons on the console.

IMPORTANT: When the current segment ends, the speed will automatically adjust to the setting programmed for the next segment.

Note: The calorie goal shown in the workout description is an estimate of the number of calories that you will burn during the workout. The actual number of calories that you burn will depend on various factors, such as your weight. In addition, if you manually change the speed during the workout, the number of calories that you burn will be affected.

To pause the workout, simply touch the screen or press the Stop button. To continue the workout, press the play icon on the screen, or press the Start button.

To end the workout, touch the screen to pause the workout, and then follow the prompts on the screen to end the workout and return to the main menu.

When the workout ends, a workout summary will appear on the screen. If desired, you can select options such as adding the workout to your schedule or adding the workout to your favorites list. Then, touch *Save Workout* to return to the main menu.

6. Disconnect your smart device from the console.

To disconnect your smart device from the console, first select the disconnect option in the iFIT app. Then, press and hold the iFIT Sync button on the console until the LED on the console turns solid green.

Note: All Bluetooth connections between the console and other devices (including any smart devices, heart rate monitors, and so forth) will be disconnected.

7. When you are finished exercising, remove the key from the console.

See step 5 on page 17.

HOW TO CONNECT A HEART RATE MONITOR TO THE CONSOLE

The console is compatible with all Bluetooth Smart heart rate monitors. **See page 20 for information about purchasing an optional heart rate monitor.**

To connect your Bluetooth Smart heart rate monitor to the console, press the iFIT Sync button on the console; the console pairing number will appear in the display. When a connection is established, the LED on the console will flash red twice.

Note: If there is more than one compatible heart rate monitor near the console, the console will connect to the heart rate monitor with the strongest signal.

To disconnect your heart rate monitor from the console, press and hold the iFIT Sync button on the console until the LED on the console turns solid green.

Note: All Bluetooth connections between the console and other devices (including any tablets, heart rate monitors, and so forth) will be disconnected.

THE SETTINGS MODE

1. Select the settings mode.

To select the settings mode, press the gear button (P).

The first settings screen will appear in the display.

Note: If you have selected a workout, you may need to press the Stop button repeatedly to return to the main menu before selecting the settings mode.

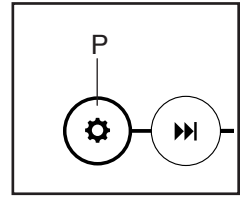

2. Navigate the settings mode.

While the settings mode is selected, you can navigate through several settings screens. Press the Stop button repeatedly to select the desired settings screen.

3. Change settings as desired.

Software Version Number—The software version number will appear in the display.

Incline System Calibration—The letters CAL will appear in the display. If the incline system is not functioning properly, it may need to be calibrated. To calibrate the incline system, press the Incline increase or decrease button. The treadmill will automatically rise to the maximum incline level and then return to the minimum level. When the treadmill stops moving, the incline system is calibrated.

Note: Occasionally, the incline calibration may run automatically when you turn on the treadmill. Wait for the calibration to be completed before attempting to use the treadmill.



Display Test—This screen is intended to be used by service technicians to identify whether the display is working correctly.

Button Test—This screen is intended to be used by service technicians to identify whether a certain button is working correctly.

Total Time—The word TIME will appear in the display. The display will show the total number of hours that the treadmill has been used.

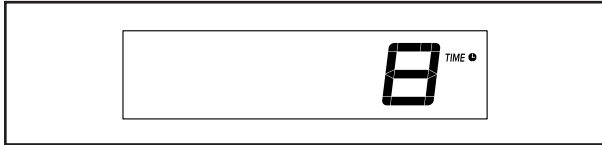

Total Distance—The letters MI or KM will appear in the display. The display will show the total distance (in miles or kilometers) that the walking belt has moved.

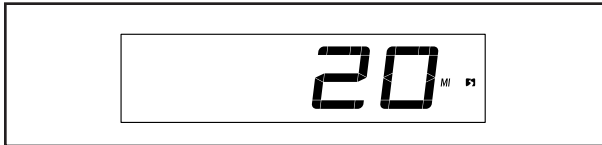

Demo Mode—The currently selected demo mode option will appear in the display. The console features a demo mode, designed to be used if the treadmill is displayed in a store. If the demo mode is turned on, the console will not turn off and the display will not be reset when you finish exercising. Press the Speed increase button repeatedly to select a demo mode option. To turn on the demo mode, select DON. To turn off the demo mode, select DOFF.



4. Exit the settings mode.

Press the gear button to exit the settings mode.

HOW TO USE THE SOUND SYSTEM

To play music or audio books through the console sound system while you exercise, plug a 3.5 mm male to 3.5 mm male audio cable (not included) into the jack on the console and into a jack on your personal audio player; **make sure that the audio cable is fully plugged in. Note: To purchase an audio cable, see your local electronics store.**

Next, press the play button on your personal audio player. Adjust the volume level using the volume control on your personal audio player.

THE OPTIONAL HEART RATE MONITOR

Whether your goal is to burn fat or to strengthen your cardiovascular system, the key to achieving the best results is to maintain the proper heart rate during your workouts. The optional wearable heart rate monitor will enable you to continuously monitor your heart rate while you exercise, helping you to reach your personal fitness goals. **To purchase a heart rate monitor, please see the front cover of this manual.**

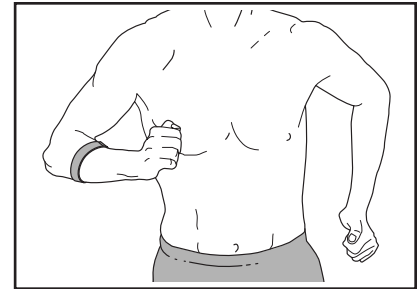

Note: The console is compatible with all Bluetooth Smart heart rate monitors.

IC INFORMATION

This device contains licence-exempt transmitter(s)/receiver(s) that comply with Innovation, Science and Economic Development Canada's licence-exempt RSS(s). Operation is subject to the following two conditions: 1. This device may not cause interference. 2. This device must accept any interference, including interference that may cause undesired operation of the device.

IMPORTANT: To satisfy exposure compliance requirements, the antenna and transmitter in the console must be at least 8 in. (20 cm) from all persons and must not be near or connected to any other antenna or transmitter.

CAN ICES-3 (B)/NMB-3(B)

Note: The console contains IC ID: 3673A-BMD1.

HOW TO FOLD AND MOVE THE TREADMILL

HOW TO FOLD THE TREADMILL

Before folding the treadmill, remove the key and unplug the power cord. **CAUTION:** You must be able to safely lift 45 lbs. (20 kg) to raise, lower, or move the treadmill.

1. Hold the metal frame (A) firmly in the location shown by the arrow below. **CAUTION: Do not hold the frame by the plastic foot rails. Bend your legs and keep your back straight.** Raise the frame about halfway to the vertical position.

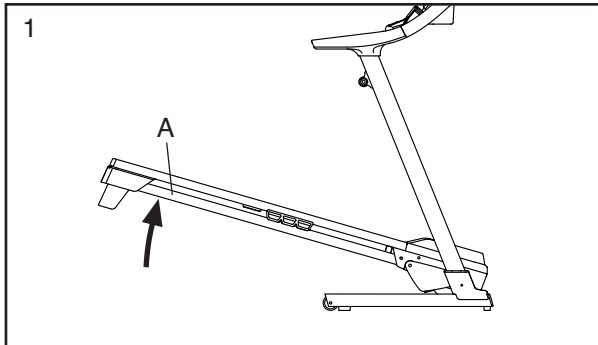

2. Hold the treadmill firmly with your right hand as shown. Pull the latch knob (B) to the left and hold it. Next, raise the frame until the latch plate (C) is past the latch pin (D). Then, slowly release the latch knob; **make sure that the latch plate is resting against the latch pin.**

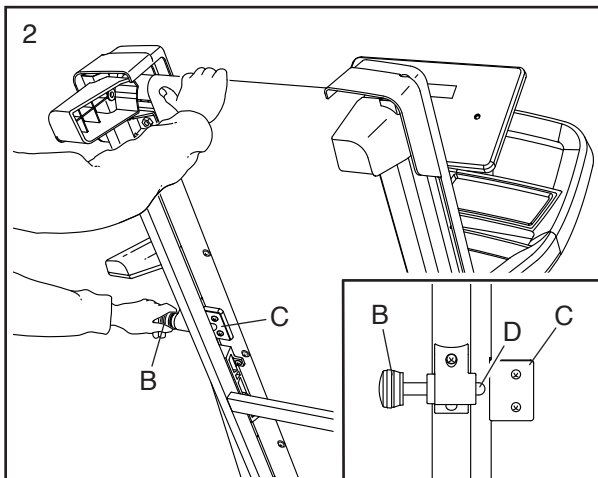

To protect the floor or carpet, place a mat under the treadmill. Keep the treadmill out of direct sunlight. Do not leave the treadmill in the storage position in temperatures above 85°F (30°C).

HOW TO MOVE THE TREADMILL

Before moving the treadmill, fold it as described at the left. **CAUTION:** Make sure that the latch plate (C) is resting against the latch pin (D). Moving the treadmill may require two people. Take any necessary measures to avoid damaging your floor.

1. Hold the frame (A) and one of the handrails (E), and place one foot against a wheel (F).

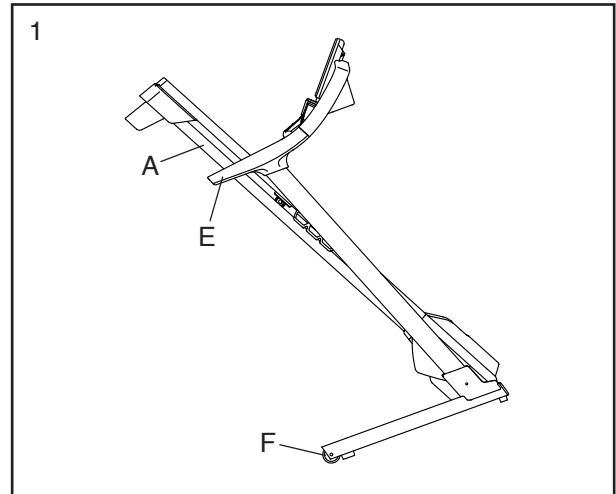

2. Pull back on the handrail (E) until the treadmill will roll on the wheels (F), and carefully move it to the desired location. **CAUTION: Do not move the treadmill without tipping it back, do not pull on the frame (A), and do not move the treadmill over an uneven surface.**
3. Place one foot against a wheel (F), and carefully lower the treadmill.

HOW TO LOWER THE TREADMILL FOR USE

1. **See drawing 2 at the left.** Hold the upper end of the treadmill with your right hand. Pull the latch knob (B) to the left and hold it. Next, lower the frame until it is past the latch pin (D). Then, release the latch knob.
2. **See drawing 1 at the left.** Hold the metal frame (A) firmly with both hands, and lower it to the floor. **CAUTION: Do not hold the frame by the plastic foot rails, and do not drop the frame. Bend your legs and keep your back straight.**

MAINTENANCE AND TROUBLESHOOTING

MAINTENANCE

Regular maintenance is important for optimal performance and to reduce wear. Inspect and properly tighten all parts each time the treadmill is used. Replace any worn parts immediately. Use only manufacturer-supplied parts.

Regularly clean the treadmill and keep the walking belt clean and dry. First, **press the power switch into the off position and unplug the power cord.** Wipe exterior parts of the treadmill with a damp cloth and a small amount of mild soap. **IMPORTANT: Do not spray liquids directly onto the treadmill. To avoid damage to the console, keep liquids away from the console.** Then, thoroughly dry the treadmill with a soft towel.

TROUBLESHOOTING

Most treadmill problems can be solved by following the simple steps below. Find the symptom that applies, and follow the steps listed. If further assistance is needed, see the front cover of this manual.

SYMPTOM: The power does not turn on

- Make sure that the power cord is plugged into a surge suppressor and that the surge suppressor is plugged into a properly grounded outlet (see page 13). Use only a surge suppressor that meets all of the specifications described on page 13. **IMPORTANT: If the treadmill is connected to an AFCI-equipped outlet and your circuit breaker trips repeatedly when the treadmill is used, see the front cover of this manual to purchase an arc filter.**
- After the power cord has been plugged in, make sure that the key is inserted into the console.

- Check the power switch located on the treadmill frame near the power cord. If the switch protrudes as shown (A), the switch has tripped. To reset the power switch, wait for five minutes and then press the switch back in (B).

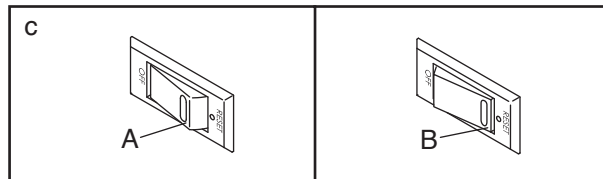

SYMPTOM: The power turns off during use

- Check the power switch (see drawing c at the left). If the switch has tripped, wait for five minutes and then press the switch back in.
- Make sure that the power cord is plugged in. If the power cord is plugged in, unplug it, wait for five minutes, and then plug it back in.
- Remove the key from the console, and then reinsert it.
- If the treadmill still will not run, please see the front cover of this manual.

SYMPTOM: The console displays remain lit when you remove the key from the console

- The console features a display demo mode, designed to be used if the treadmill is displayed in a store. If the displays remain lit when you remove the key, the demo mode is turned on. To turn off the demo mode, hold down the Stop button for a few seconds. If the displays are still lit, see THE SETTINGS MODE on pages 19 and 20 to turn off the demo mode.

SYMPTOM: The incline of the treadmill does not change correctly

- Calibrate the incline system (see step 3 on page 19).

SYMPTOM: The walking belt slows when walked on

- a. Use only a surge suppressor that meets all of the specifications described on page 13.
- b. If the walking belt is overtightened, treadmill performance may decrease and the walking belt may become damaged. Remove the key and **UNPLUG THE POWER CORD**. Using the hex key, turn both idler roller screws (C) counterclockwise, 1/4 of a turn. When the walking belt is properly tightened, you should be able to lift each edge of the walking belt 2 to 3 in. (5 to 7 cm) off the walking platform. Be careful to keep the walking belt centered. Then, plug in the power cord, insert the key, and walk on the treadmill for a few minutes. Repeat until the walking belt is properly tightened.

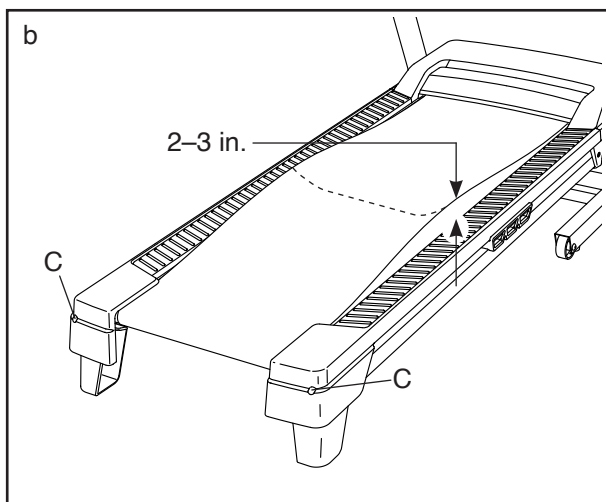

- c. Your treadmill features a walking belt coated with high-performance lubricant. **IMPORTANT: Never apply silicone spray or other substances to the walking belt or the walking platform unless instructed to do so by an authorized service representative. Such substances may deteriorate the walking belt and cause excessive wear.** If you suspect that the walking belt needs more lubricant, see the front cover of this manual.
- d. If the walking belt still slows when walked on, see the front cover of this manual.

SYMPTOM: The walking belt is off-center or slips when walked on

- a. **If the walking belt is off-center**, first remove the key and **UNPLUG THE POWER CORD**. **If the walking belt has shifted to the left**, use the hex key to turn the left idler roller screw clockwise 1/2 of a turn; **if the walking belt has shifted to the right**, turn the left idler roller screw counterclockwise 1/2 of a turn. Be careful not to overtighten the walking belt. Then, plug in the power cord, insert the key, and walk on the treadmill for a few minutes. Repeat until the walking belt is centered.

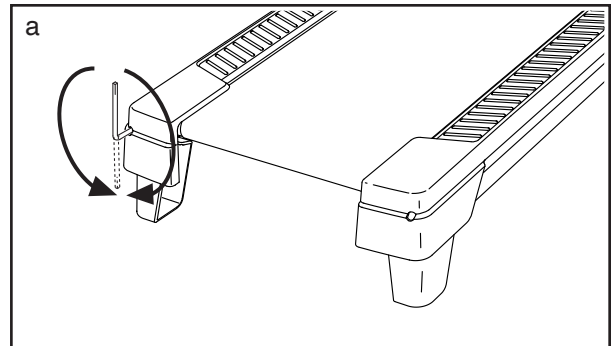

- b. **If the walking belt slips when walked on**, first remove the key and **UNPLUG THE POWER CORD**. Using the hex key, turn both idler roller screws clockwise, 1/4 of a turn. When the walking belt is correctly tightened, you should be able to lift each edge of the walking belt 2 to 3 in. (5 to 7 cm) off the walking platform. Be careful to keep the walking belt centered. Then, plug in the power cord, insert the key, and walk on the treadmill for a few minutes. Repeat until the walking belt is properly tightened.

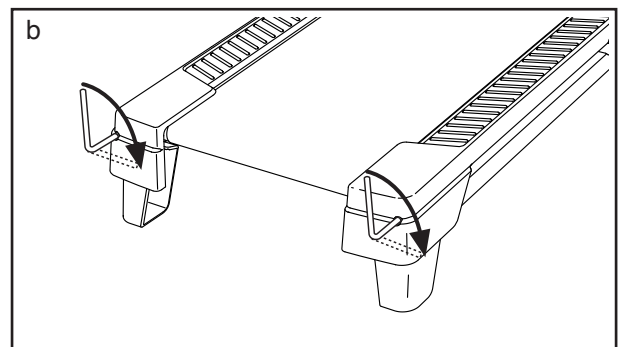

EXERCISE GUIDELINES

⚠️ WARNING: Before beginning this or any exercise program, consult your physician. This is especially important for persons over age 35 or persons with pre-existing health problems.

These guidelines will help you to plan your exercise program. For detailed exercise information, obtain a reputable book or consult your physician. Remember, proper nutrition and adequate rest are essential for successful results.

EXERCISE INTENSITY

Whether your goal is to burn fat or to strengthen your cardiovascular system, exercising at the proper intensity is the key to achieving results. You can use your heart rate as a guide to find the proper intensity level. The chart below shows recommended heart rates for fat burning and aerobic exercise.

165	155	145	140	130	125	115	♥️
145	138	130	125	118	110	103	♥️
125	120	115	110	105	95	90	♥️
<hr/>							
20	30	40	50	60	70	80	

To find the proper intensity level, find your age at the bottom of the chart (ages are rounded off to the nearest ten years). The three numbers listed above your age define your “training zone.” The lowest number is the heart rate for fat burning, the middle number is the heart rate for maximum fat burning, and the highest number is the heart rate for aerobic exercise.

Burning Fat—To burn fat effectively, you must exercise at a low intensity level for a sustained period of time. During the first few minutes of exercise, your body uses carbohydrate calories for energy. Only after the first few minutes of exercise does your body begin to use stored fat calories for energy. If your goal is to burn fat, adjust the intensity of your exercise until your heart rate is near the lowest number in your training zone. For maximum fat burning, exercise with your heart rate near the middle number in your training zone.

Aerobic Exercise—If your goal is to strengthen your cardiovascular system, you must perform aerobic exercise, which is activity that requires large amounts of oxygen for prolonged periods of time. For aerobic exercise, adjust the intensity of your exercise until your heart rate is near the highest number in your training zone.

HOW TO MEASURE YOUR HEART RATE

To measure your heart rate, exercise for at least four minutes. Then, stop exercising and place two fingers on your wrist as shown. Take a six-second heartbeat count, and multiply the result by 10 to find your heart rate. For example, if your six-second heartbeat count is 14, your heart rate is 140 beats per minute.

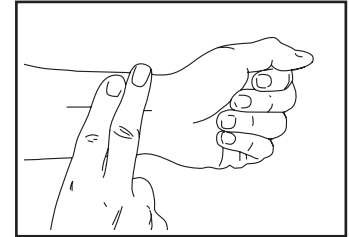

WORKOUT GUIDELINES

Warming Up—Start with 5 to 10 minutes of stretching and light exercise. A warm-up increases your body temperature, heart rate, and circulation in preparation for exercise.

Training Zone Exercise—Exercise for 20 to 30 minutes with your heart rate in your training zone. (During the first few weeks of your exercise program, do not keep your heart rate in your training zone for longer than 20 minutes.) Breathe regularly and deeply as you exercise; never hold your breath.

Cooling Down—Finish with 5 to 10 minutes of stretching. Stretching increases the flexibility of your muscles and helps to prevent post-exercise problems.

EXERCISE FREQUENCY

To maintain or improve your condition, complete three workouts each week, with at least one day of rest between workouts. After a few months of regular exercise, you may complete up to five workouts each week, if desired. Remember, the key to success is to make exercise a regular and enjoyable part of your everyday life.

PART LIST

Model No. PFTL39621C.0 R0721A

Key No.	Qty.	Description	Key No.	Qty.	Description
1	2	3/8" x 2 1/4" Screw	49	1	Walking Belt
2	4	M8 x 50mm Screw	50	2	Platform Cushion
3	2	3/8" x 3/4" Screw	51	2	Belt Guide
4	5	Hood Clip	52	1	Drive Roller/Pulley
5	24	M4.2 x 19mm Screw	53	1	Drive Belt
6	2	#8 x 3/8" Screw	54	1	Controller
7	4	M8 Star Washer	55	1	Controller Clamp
8	2	M8 x 35mm Screw	56	1	Electronics Bracket
9	4	M4.2 x 13mm Washer Head Screw	57	1	Frame
10	2	M4.2 x 25mm Screw	58	1	Drive Motor
11	2	#8 x 5/8" Screw	59	1	Drive Motor Bracket
12	4	M4.2 x 19mm Tek Screw	60	1	Right Rear Foot
13	7	M4.2 x 19mm Washer Head Screw	61	1	Left Rear Foot
14	11	M4 x 10mm Screw	62	1	Motor Hood
15	4	M8 x 30mm Screw	63	4	Frame Spacer
16	4	M4.2 x 13mm Belt Guide Screw	64	1	Incline Motor
17	2	M6 x 70mm Screw	65	1	Lift Frame
18	2	1/4" x 3/8" Screw	66	2	M10 Flat Washer
19	1	M8 x 102mm Bolt	67	1	Power Cord
20	2	#10 x 3/4" Screw	68	1	Power Cord grommet
21	2	#10 Star Washer	69	1	Power Switch
22	2	M8 x 20mm Bolt	70	1	Belly Pan
23	2	3/8" x 2" Bolt	71	1	Left Handrail Top
24	2	M8 x 40mm Screw	72	1	Right Handrail Top
25	2	M10 x 58mm Bolt	73	1	Left Handrail Bottom
26	2	M10 x 58mm Screw	74	1	Right Handrail Bottom
27	1	3/8" x 1 1/4" Bolt	75	1	Ground Wire
28	1	3/8" x 2" Hex Head Bolt	76	1	Handrail
29	32	#8 x 3/4" Screw	77	1	Crossbar
30	1	M6 x 60mm Bolt	78	1	Upright Wire
31	2	1/4" Flat Washer	79	1	Storage Latch
32	1	Incline Motor Spacer	80	1	Left Upright
33	4	M6 Star Washer	81	1	Right Upright
34	14	Small Washer	82	1	Left Outer Upright Cover
35	1	M8 Jam Nut	83	1	Left Inner Upright Cover
36	2	M10 Star Washer	84	1	Right Inner Upright Cover
37	2	M8 Flange Nut	85	1	Right Outer Upright Cover
38	4	M8 Nut	86	2	Base Cap
39	4	3/8" Jam Nut	87	4	Round Base Pad
40	1	M6 Nut	88	1	Grommet
41	1	Latch Plate Spacer	89	1	Key/Clip
42	2	M8 Weld Nut	90	1	Base
43	2	M10 Nut	91	2	Caution Decal
44	1	Left Foot Rail	92	2	Cable Tie
45	1	Right Foot Rail	93	2	Wheel
46	1	Warning Decal	94	1	Left Tray
47	1	Latch Plate	95	1	Right Tray
48	1	Walking Platform	96	1	Console Base

Key No.	Qty.	Description	Key No.	Qty.	Description
97	1	Console	100	1	Idler Roller
98	1	Right Idler Roller Bracket	101	1	French Warning Decal
99	1	Left Idler Roller Bracket	*	–	User's Manual

Note: Specifications are subject to change without notice. For information about ordering replacement parts, see the back cover of this manual. *These parts are not illustrated.

EXPLODED DRAWING A

Model No. PFTL39621C.0 R0721A

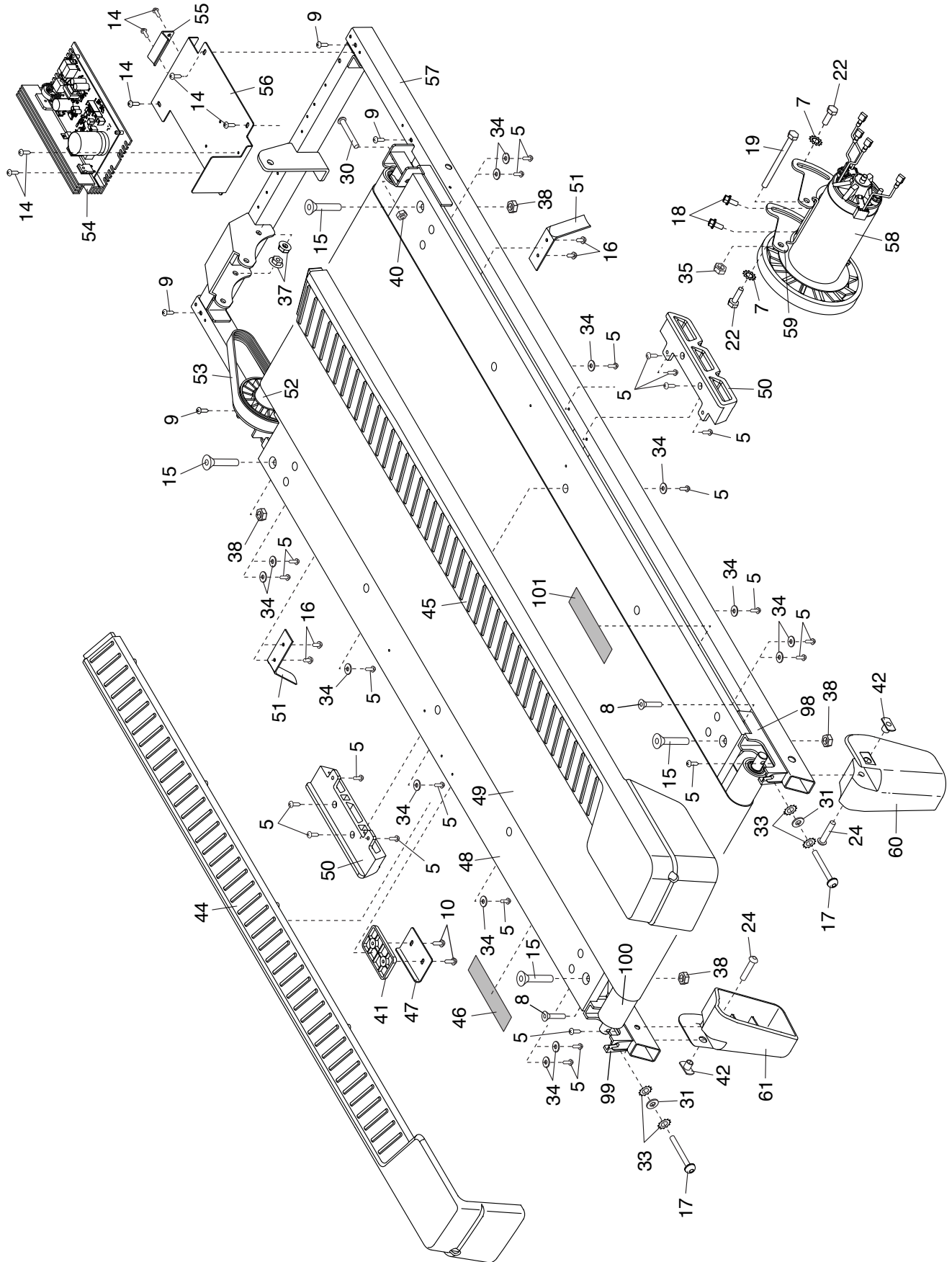

EXPLODED DRAWING B

Model No. PFTL39621C.0 R0721A

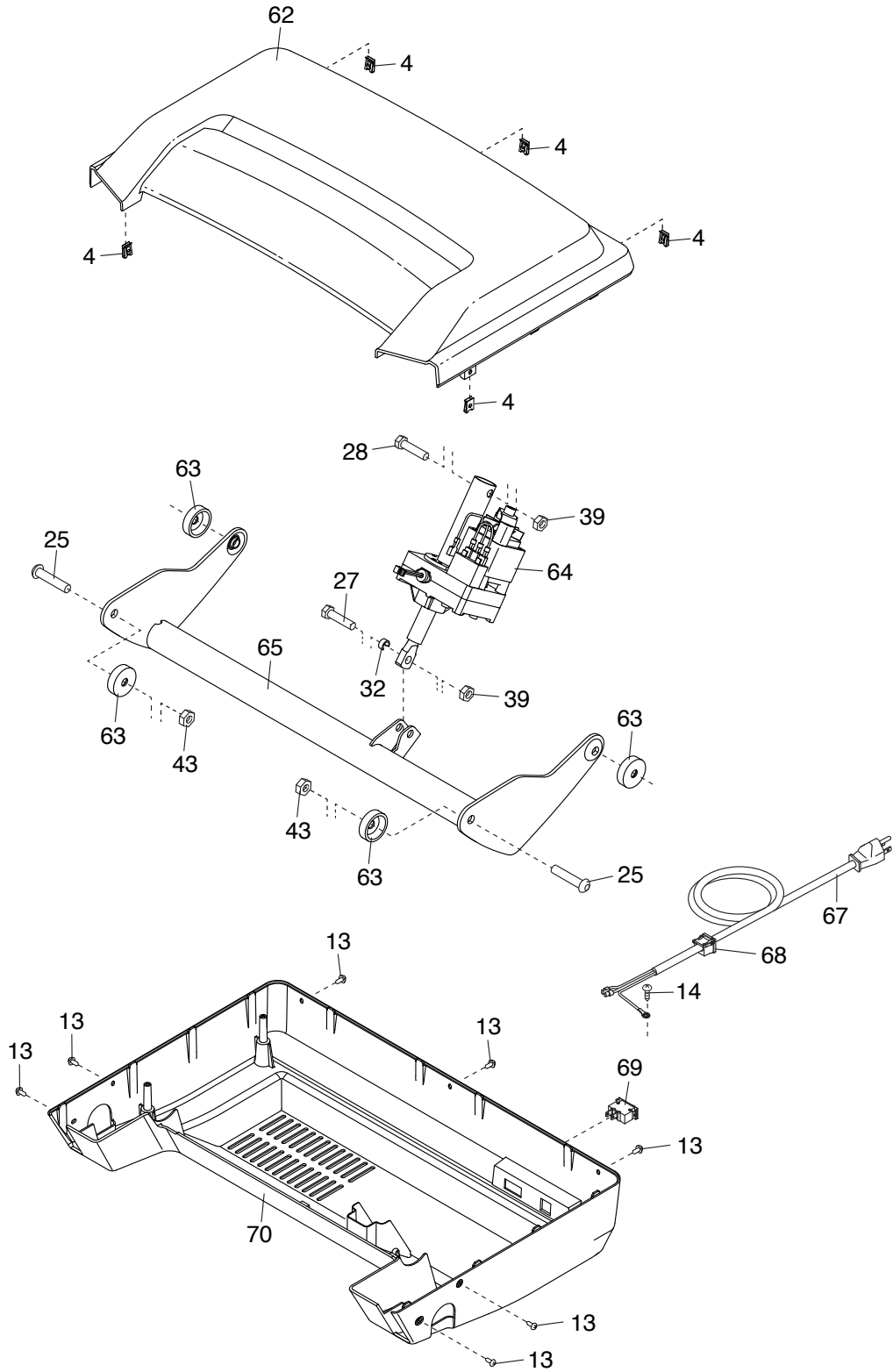

EXPLODED DRAWING C

Model No. PFTL39621C.0 R0721A

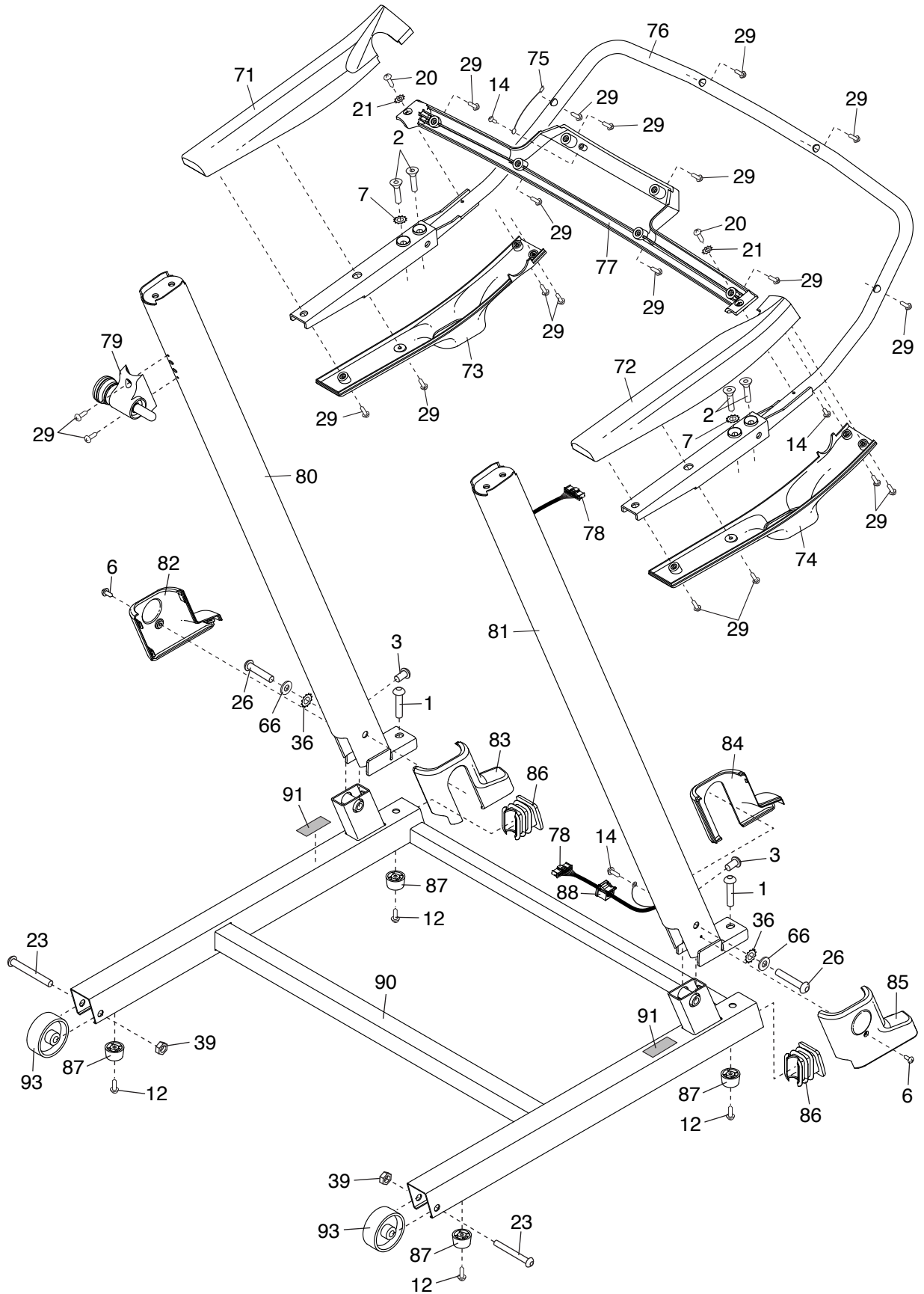

EXPLODED DRAWING D

Model No. PFTL39621C.0 R0721A

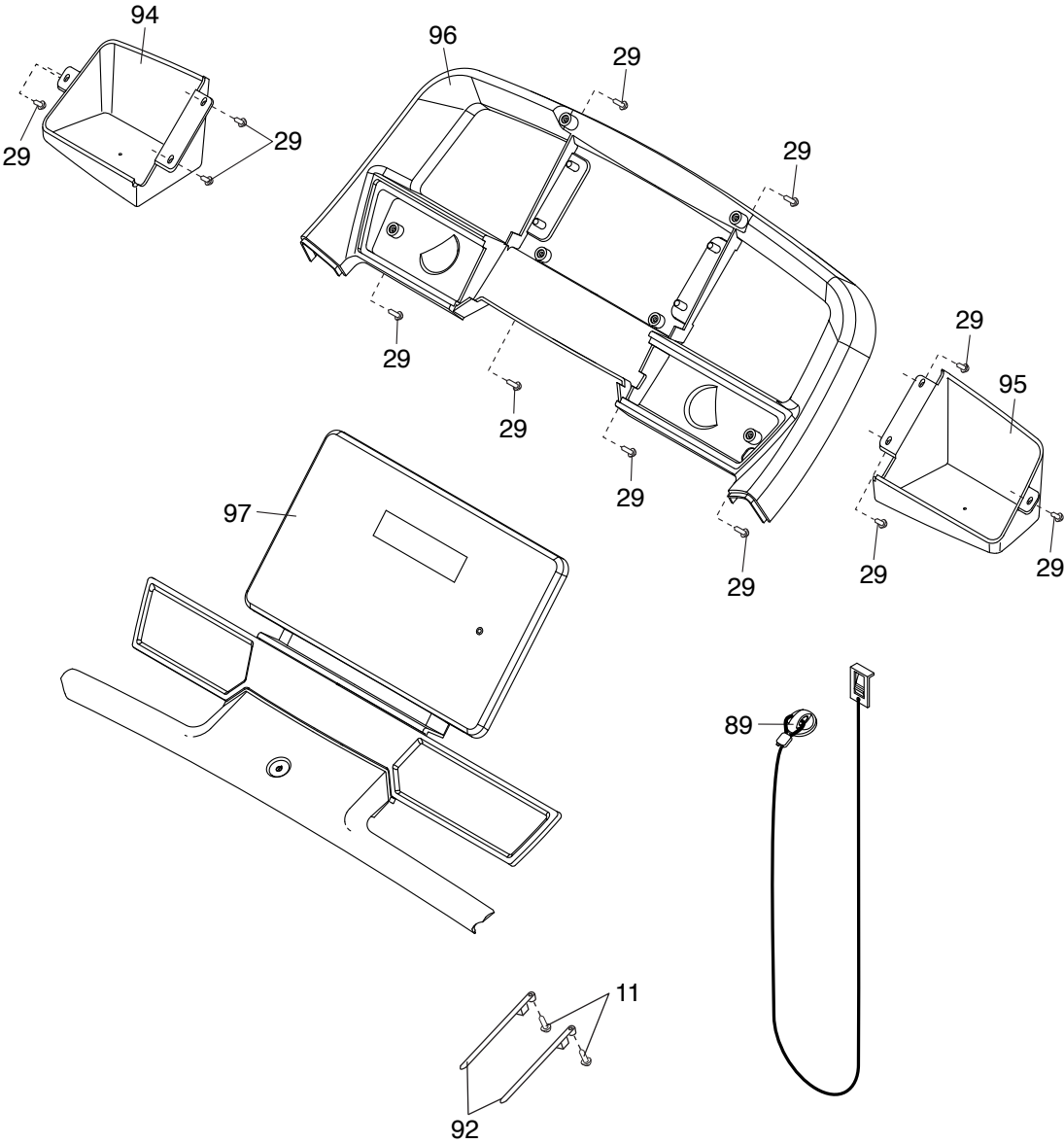

ORDERING REPLACEMENT PARTS

To order replacement parts, please see the front cover of this manual. To help us assist you, be prepared to provide the following information when contacting us:

- the model number and serial number of the product (see the front cover of this manual)
- the name of the product (see the front cover of this manual)
- the key number and description of the replacement part(s) (see the PART LIST and the EXPLODED DRAWING near the end of this manual)

LIMITED WARRANTY

IMPORTANT: To protect your fitness equipment with an extended service plan, see page 5.

ICON of Canada, Inc. (ICON) warrants this product to be free from defects in workmanship and material, under normal use and service conditions. The frame is warranted for five (5) years from the date of purchase. Parts and labor are warranted for ninety (90) days from the date of purchase

This warranty extends only to the original purchaser (customer) and is not transferrable. ICON's obligation under this warranty is limited to repairing or replacing, at ICON's discretion, the product through one of its authorized service providers. All repairs for which warranty claims are made must be preauthorized by ICON. If replacement parts are shipped while the product is under warranty, the customer will be responsible for a minimal handling charge. For in-home service, the customer may be responsible for a minimal trip charge. This warranty does not extend to freight damage to the product. This warranty will automatically be voided by the following conditions: (1) if the product is used as a store display model, (2) if the product is purchased or transported outside of Canada, (3) if any instruction or warning in this manual is not followed, (4) if the product is abused or improperly or abnormally used, (5) if the product is modified to alter functionality or capability without the written permission of ICON, or (6) if the product is used for commercial or rental purposes. No other warranty beyond that specifically set forth above is authorized by ICON.

ICON is not responsible or liable for the following damages: (1) indirect, special, or consequential damages arising out of or in connection with the use or performance of the product; (2) damages with respect to any economic loss, loss of property, loss of revenues or profits, loss of enjoyment or use, or costs of removal or installation; or (3) other consequential damages of any kind. Some provinces do not allow the exclusion or limitation of incidental or consequential damages. Accordingly, the above limitation may not apply to the customer.

The warranty extended hereunder is in lieu of any and all other warranties, and any implied warranties of merchantability or fitness for a particular purpose are limited in their scope and duration to the terms set forth herein. Some provinces do not allow limitations on how long an implied warranty lasts. Accordingly, the above limitation may not apply to the customer. This warranty provides specific legal rights; the customer may have other rights that vary from province to province.

For warranty service, please call the telephone number on the front cover of this manual. Please be prepared to provide the model number and serial number of the product (see the front cover of this manual).

ICON of Canada, Inc., 900 de l'Industrie, St. Jérôme, QC J7Y 4B8