

# PRO-FORM®

# SPORT E2.0

proform.com

Model No. PFEL02920.0

Serial No. \_\_\_\_\_

Write the serial number in the space above for reference.

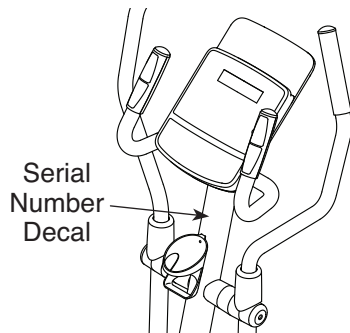

## ACTIVATE YOUR WARRANTY

To register your product and activate your warranty today, go to [my.proform.com](http://my.proform.com).

## CUSTOMER CARE

For service at any time, go to [support.proform.com](http://support.proform.com).

Or call 1-888-533-1333  
Mon.–Fri. 6 a.m.–6 p.m. MT  
Sat. 8 a.m.–12 p.m. MT

Please do not contact the store.

## ⚠ CAUTION

Read all precautions and instructions in this manual before using this equipment. Keep this manual for future reference.

# USER'S MANUAL

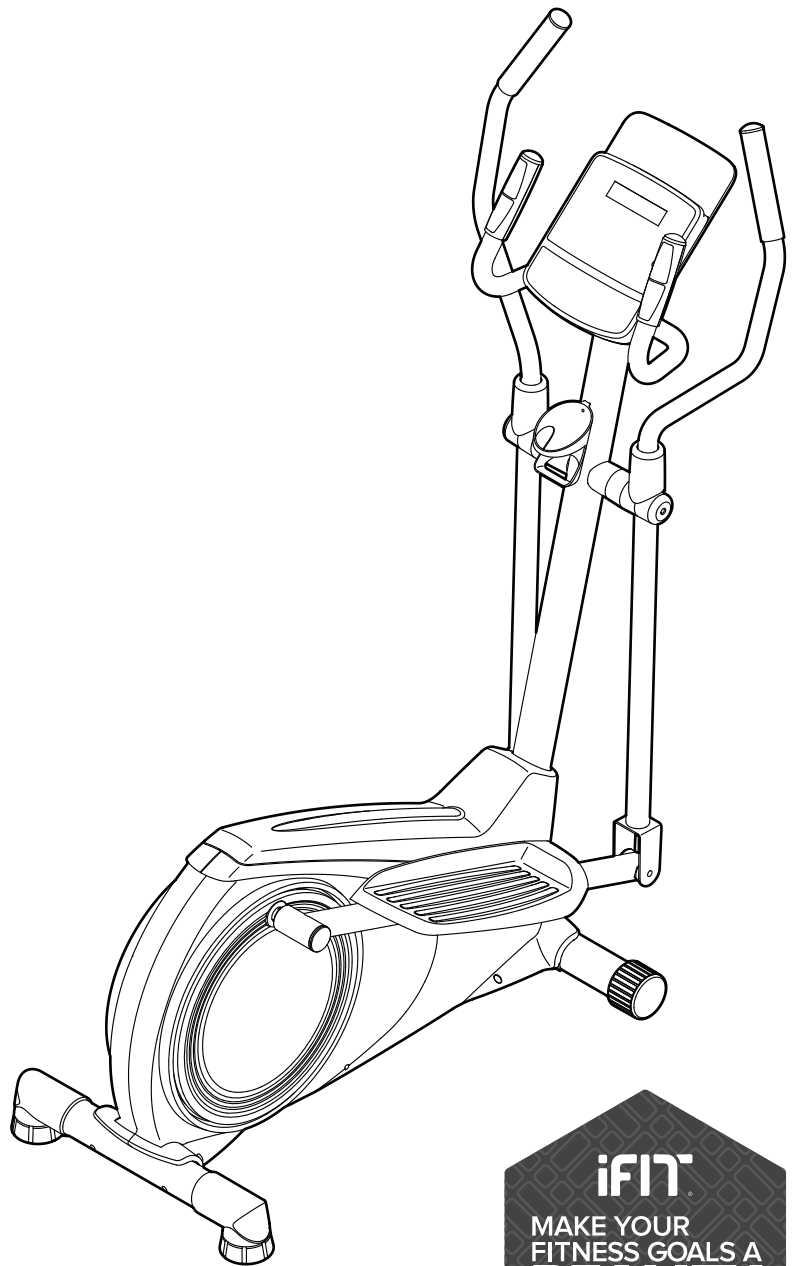

**IFIT**

MAKE YOUR  
FITNESS GOALS A  
**REALITY**

[IFIT.COM](http://IFIT.COM)

# TABLE OF CONTENTS

WARNING DECAL PLACEMENT ..... 2

IMPORTANT PRECAUTIONS..... 3

BEFORE YOU BEGIN..... 5

PART IDENTIFICATION CHART..... 6

ASSEMBLY..... 7

HOW TO USE THE ELLIPTICAL ..... 15

HOW TO USE THE CONSOLE..... 17

FCC INFORMATION..... 23

MAINTENANCE AND TROUBLESHOOTING ..... 24

EXERCISE GUIDELINES..... 26

PART LIST..... 29

EXPLODED DRAWING..... 30

ORDERING REPLACEMENT PARTS ..... Back Cover

LIMITED WARRANTY..... Back Cover

## WARNING DECAL PLACEMENT

This drawing shows the location(s) of the warning decal(s).  
**If a decal is missing or illegible, see the front cover of this manual and request a free replacement decal.**  
**Apply the decal in the location shown.** Note: The decal(s) may not be shown at actual size.

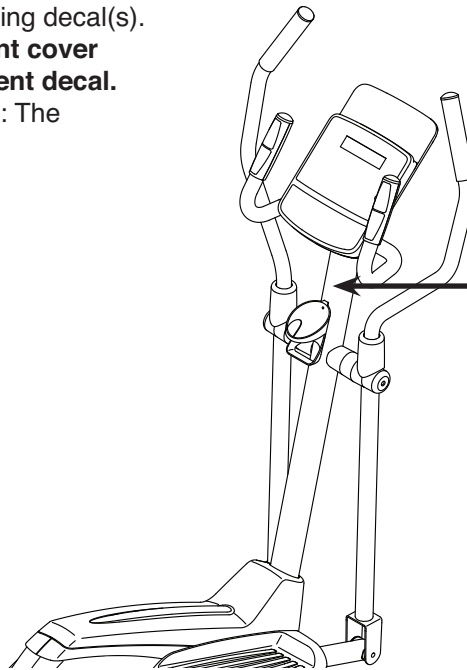

**⚠ WARNING**

- Misuse of this machine may result in serious injury.
- Read user's manual prior to use and follow all warnings and instructions.
- Do not allow children on or around machine.
- Pedals continue to spin when you stop pedaling.
- Spinning pedals can cause injury.
- Reduce pedal speed in a controlled manner.
- User weight must not exceed 250 lbs / 113 kgs.
- This product should always be used on a level surface.
- This product is not intended for therapeutic use.
- Replace label if damaged, illegible, or removed.



PROFORM and IFIT are registered trademarks of ICON Health & Fitness, Inc. App Store is a trademark of Apple Inc., registered in the U.S. and other countries. Android and Google Play are trademarks of Google LLC. The Bluetooth® word mark and logos are registered trademarks of Bluetooth SIG, Inc. and are used under license. IOS is a trademark or registered trademark of Cisco in the U.S. and other countries and is used under license.

# IMPORTANT PRECAUTIONS

**⚠️ WARNING:** To reduce the risk of serious injury, read all important precautions and instructions in this manual and all warnings on your elliptical before using your elliptical. ICON assumes no responsibility for personal injury or property damage sustained by or through the use of this product.

1. It is the responsibility of the owner to ensure that all users of the elliptical are adequately informed of all precautions.
2. Before beginning any exercise program, consult your physician. This is especially important for persons over age 35 or persons with pre-existing health problems.
3. The elliptical is not intended for use by persons with reduced physical, sensory, or mental capabilities or lack of experience and knowledge, unless they are given supervision or instruction about use of the elliptical by someone responsible for their safety.
4. Use the elliptical only as described in this manual.
5. The elliptical is intended for home use only. Do not use the elliptical in a commercial, rental, or institutional setting.
6. Keep the elliptical indoors, away from moisture and dust. Do not put the elliptical in a garage or covered patio, or near water.
7. Place the elliptical on a level surface, with at least 3 ft. (0.9 m) of clearance in the front and rear of the elliptical and 2 ft. (0.6 m) on each side. To protect the floor or carpet from damage, place a mat under the elliptical.
8. Inspect and properly tighten all parts each time the elliptical is used. Replace any worn parts immediately.
9. Keep children under age 16 and pets away from the elliptical at all times.
10. The elliptical should not be used by persons weighing more than 250 lbs. (113 kg).
11. Wear appropriate clothes while exercising; do not wear loose clothes that could become caught on the elliptical. Always wear athletic shoes for foot protection while exercising.
12. Hold the handlebars or the upper body arms when mounting, dismounting, or using the elliptical. Before mounting or dismounting, bring the pedals to a stop with the pedal on the mounting or dismounting side in its lowest position.
13. The heart rate monitor is not a medical device. Various factors may affect the accuracy of heart rate readings. The heart rate monitor is intended only as an exercise aid in determining heart rate trends in general.
14. The elliptical does not have a freewheel; the pedals will continue to move until the flywheel stops. Reduce your pedaling speed in a controlled way.
15. Keep your back straight while using the elliptical; do not arch your back.
16. Over exercising may result in serious injury or death. If you feel faint, if you become short of breath, or if you experience pain while exercising, stop immediately and cool down.

# PROTECT

YOUR FITNESS EQUIPMENT  
WITH AN EXTENDED SERVICE PLAN



Your new fitness equipment is not an ordinary purchase; it is an investment in your health and well being for years to come.

As the leading provider of manufacturer's extended service plans, ICON strives to protect your equipment and your future.

Please review the following service plans and find one that best fits your needs.

## PREVENTIVE MAINTENANCE SERVICE PLANS

Equipment Price	3-Year Plan	5-Year Plan
\$0.00 to \$1000.00	\$199.99	\$289.99
\$1001.00 to \$1500.00	\$259.99	\$379.99
\$1501.00 to \$2500.00	\$339.99	\$489.99
(Bikes/Systems Only) \$0.00 to \$2500.00	\$139.99	NA

### Features:

- Includes an annual preventive maintenance and performance check at your convenience
- Unlimited in-home repairs; no shipping required
- Covers parts and labor on all manufacturer's defects, as well as wear and tear on parts
- Up to 5 years of coverage available

## STANDARD SERVICE PLANS

Equipment Price	1-Year Plan	2-Year Plan	3-Year Plan
\$0.00 to \$300.00	\$29.99	\$39.99	\$59.99
\$301.00 to \$1000.00	\$89.99	\$119.99	\$149.99
\$1001.00 to \$2000.00	\$109.99	\$139.99	\$179.99
\$2001.00 to \$3000.00	\$179.99	\$209.99	\$239.99

### Features:

- Unlimited in-home repairs; no shipping required
- Covers parts and labor on all manufacturer's defects, as well as wear and tear on parts
- Up to 3 years of coverage available

To protect your fitness equipment today, please  
call Customer Care at **1-800-677-3838.**  
Or, visit us online at **www.utserv.com.**



# BEFORE YOU BEGIN

Thank you for selecting the new PROFORM® SPORT E2.0 elliptical. The SPORT E2.0 elliptical provides a selection of features designed to make your workouts at home more effective and enjoyable.

**For your benefit, read this manual carefully before you use the elliptical.** If you have questions after reading this manual, please see the front cover of this

manual. To help us assist you, note the product model number and serial number before contacting us. The model number and the location of the serial number decal are shown on the front cover of this manual.

Before reading further, please familiarize yourself with the parts that are labeled in the drawing below.

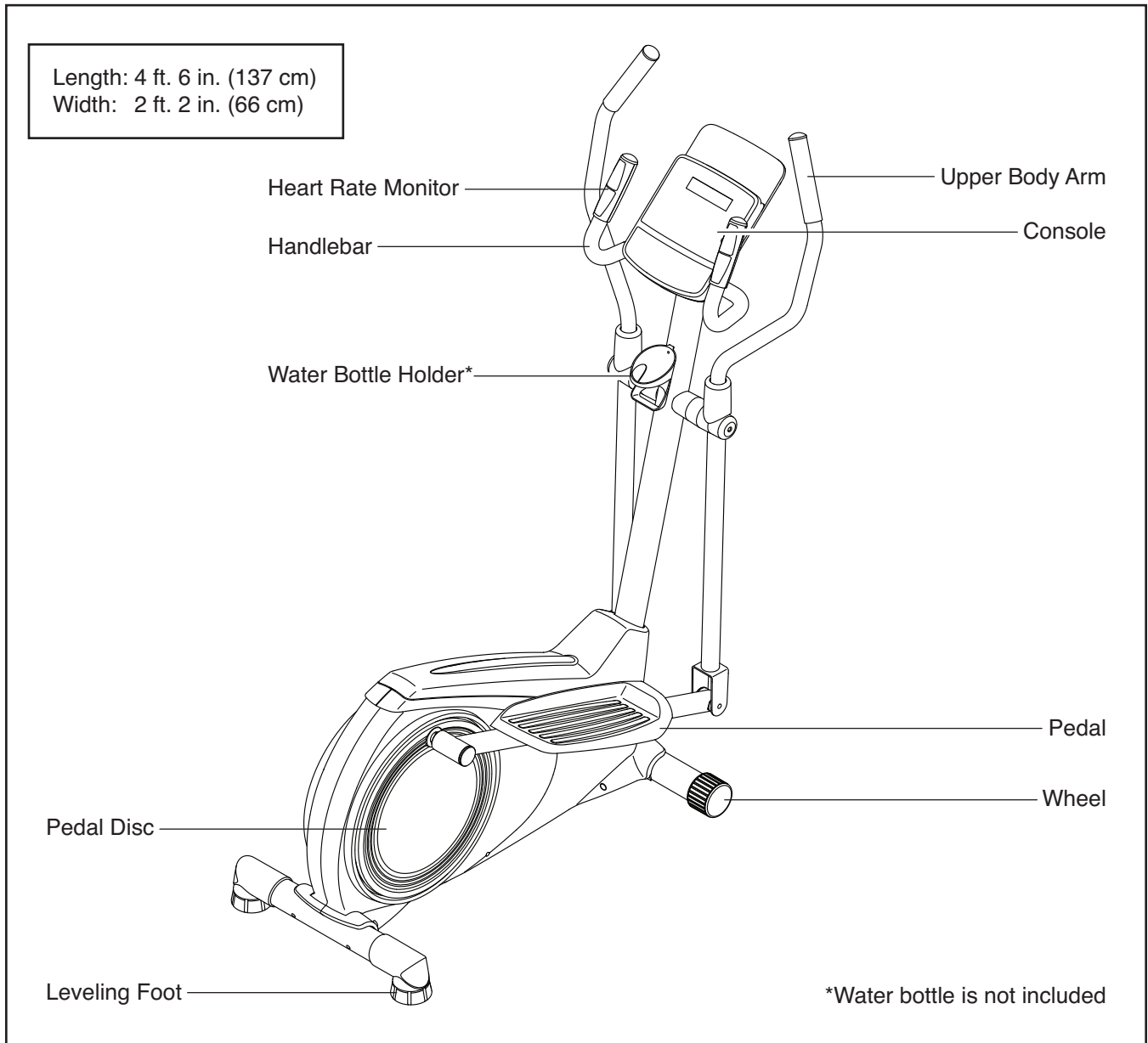

# PART IDENTIFICATION CHART

Use the drawings below to identify the small parts needed for assembly. The number in parentheses below each drawing is the key number of the part, from the PART LIST near the end of this manual. The number following the key number is the quantity needed for assembly. **Note: If a part is not in the hardware kit, check to see if it has been preassembled.**

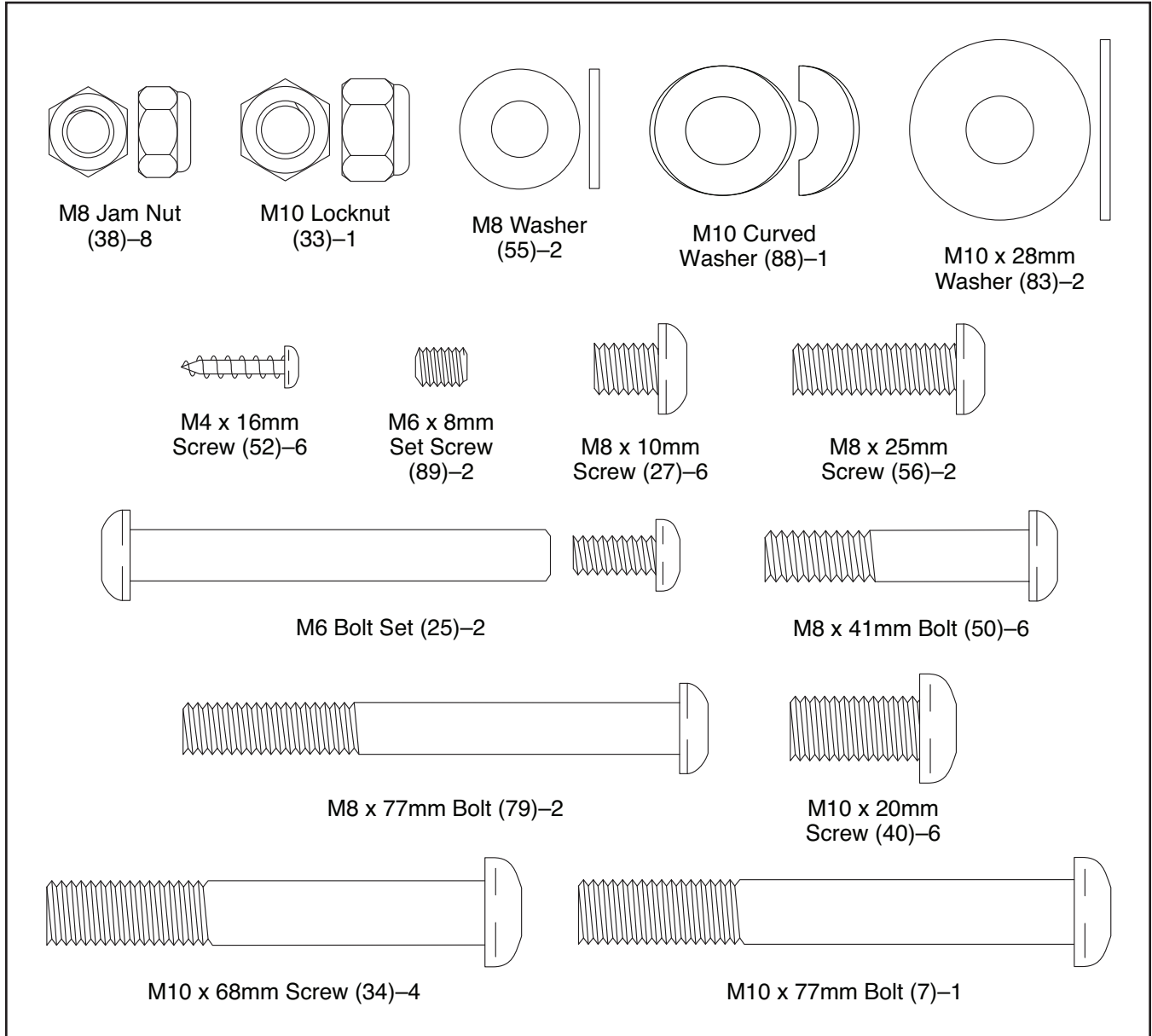

# ASSEMBLY

- To hire an authorized service technician to assemble this product, call 1-800-445-2480.
- Assembly requires two persons.
- Place all parts in a cleared area and remove the packing materials. Do not dispose of the packing materials until you finish all assembly steps.
- Left and right parts are marked “L” or “Left” and “R” or “Right.”
- To identify small parts, see page 6.

- In addition to the included tool(s), assembly requires the following tools:

one adjustable wrench



one Phillips screwdriver

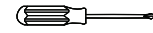

one rubber mallet



Assembly may be easier if you have a set of wrenches. To avoid damaging parts, do not use power tools.

## 1. Go to [my.proform.com](http://my.proform.com) on your computer and register your product.

- documents your ownership
- activates your warranty
- ensures priority customer support if assistance is ever needed

Note: If you do not have internet access, call Customer Care (see the front cover of this manual) and register your product.

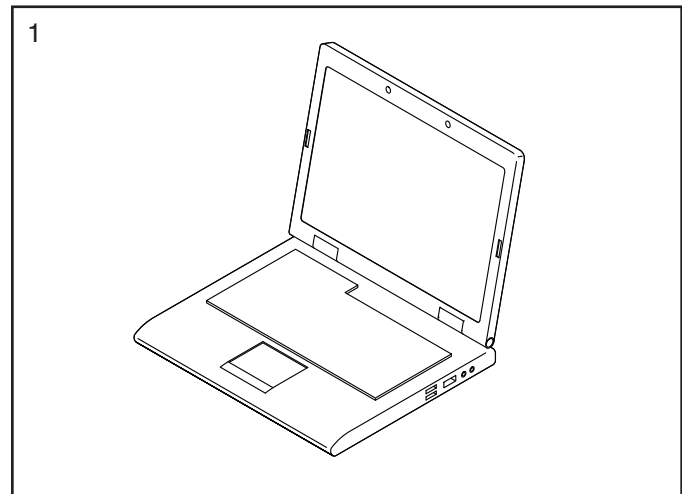

## 2. Identify the Front Stabilizer (63), and orient it as indicated by the sticker. **Make sure that the large holes (A) in the Front Stabilizer are facing the Frame (1).**

While a second person lifts the front of the Frame (1), attach the Front Stabilizer (63) to the Frame with two M10 x 68mm Screws (34).

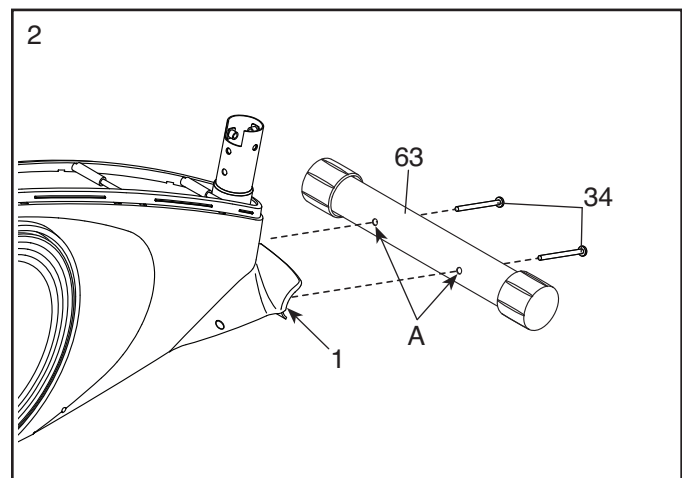

3. Orient the Rear Stabilizer (9) as indicated by the sticker.

While a second person lifts the rear of the Frame (1), attach the Rear Stabilizer (9) to the Frame with two M10 x 68mm Screws (34).

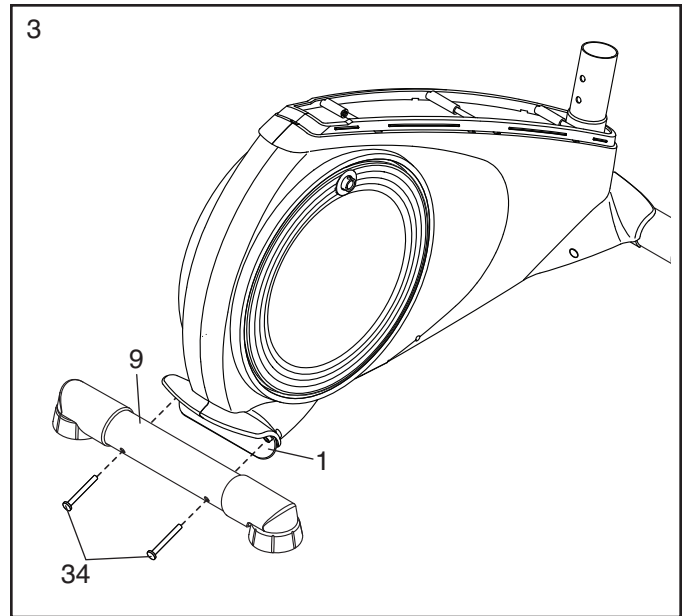

4. Orient the Upright (2) and the Top Shield (41) as shown. Slide the Top Shield upward onto the Upright. **Do not remove the wire ties (B, C) from the Upright.**

Next, slide the Upright (2) onto the Frame (1).

Attach the Upright (2) with four M10 x 20mm Screws (40), an M10 x 77mm Bolt (7), an M10 Curved Washer (88), and an M10 Locknut (33); **do not tighten the Screws and the Locknut yet.**

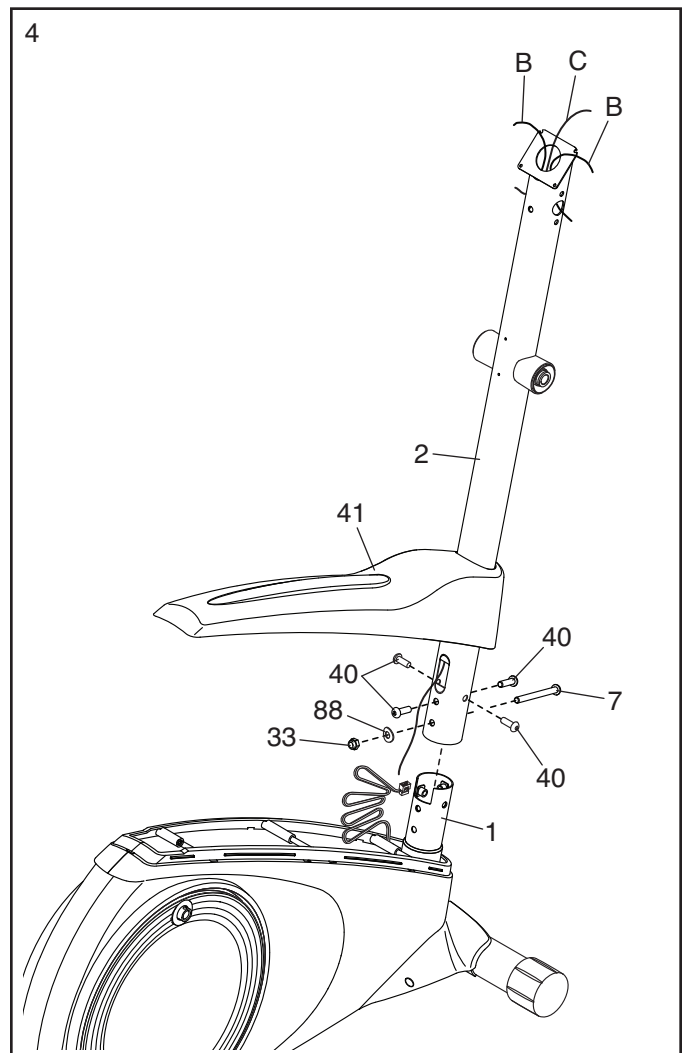

5. **See the inset drawing.** Locate the wire tie (C) in the lower end of the Upright (2). Tie the wire tie to the Wire Harness (73). Next, pull the upper end of the wire tie until the Wire Harness is routed through the Upright.

**Tip: To prevent the Wire Harness (73) from falling into the Upright (2), secure the Wire Harness with the wire tie (C).**

Next, slide the Top Shield (41) downward to the Frame (1); **do not press the Top Shield into place yet.**

Then, attach the Water Bottle Holder (29) to the Upright (2) with two M4 x 16mm Screws (52).

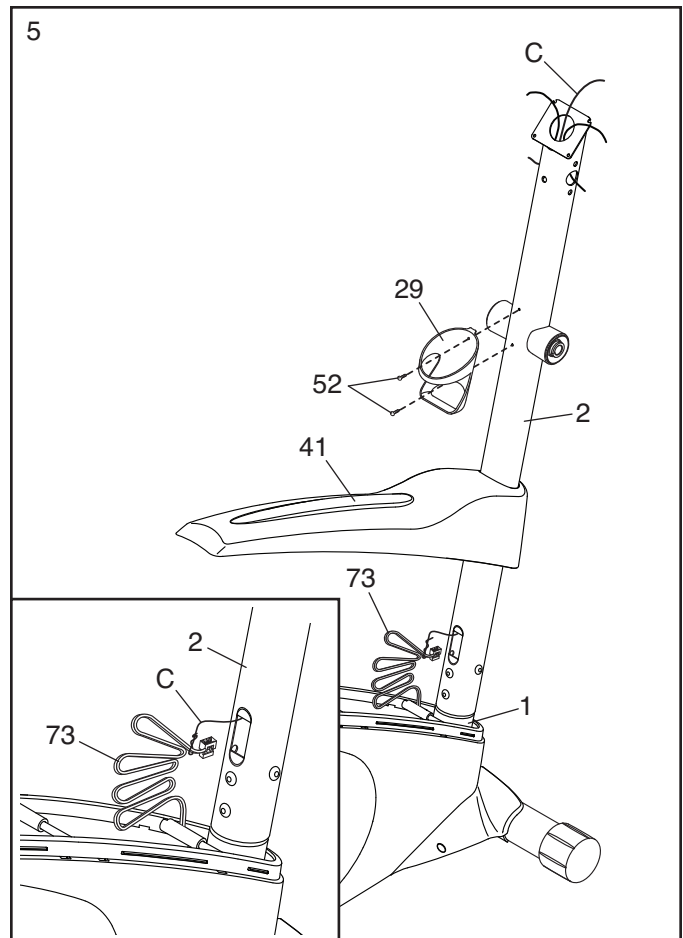

6. Identify the Left and Right Handlebars (85, 86).

Have a second person hold the Left and Right Handlebars (85, 86) near the Upright (2). Next, locate the remaining two wire ties (B) inside the Upright. Tie the lower ends of the wire ties to the Pulse Wires (84). Then, pull the upper ends of the wire ties upward out of the top of the Upright.

**Tip: While inserting the M8 x 77mm Bolts (79), avoid damaging the Wire Harness (73) and the Pulse Wires (84) inside the Upright (2).**

Attach the Left and Right Handlebars (85, 86) to the Upright (2) with two M8 x 77mm Bolts (79) and two M8 Jam Nuts (38).

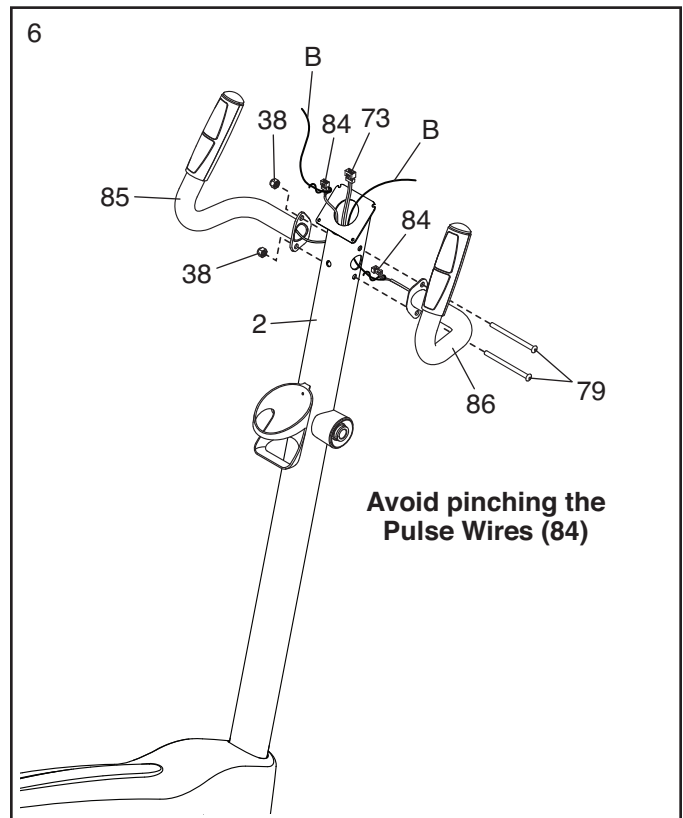

7. While a second person holds the Console (23) near the Upright (2), plug the Wire Harness (73) and the Pulse Wires (84) into the receptacles (D) on the Console.

**The connectors on the Wire Harness (73) and the Pulse Wires (84) should slide easily into the receptacles (D) and snap into place. If a connector does not slide easily into a receptacle, turn the connector and try again. If you do not connect the connectors properly, the Console (23) may become damaged when you use the elliptical.**

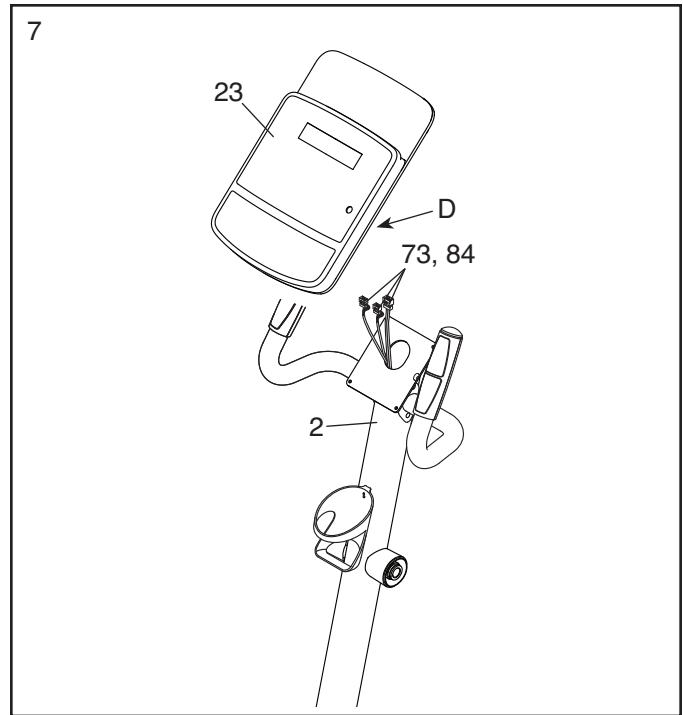

8. Insert the excess wire into the Upright (2).

**Tip: Avoid pinching the wires.** Attach the Console (23) to the Upright (2) with four M4 x 16mm Screws (52); **start all the Screws, and then tighten them.**

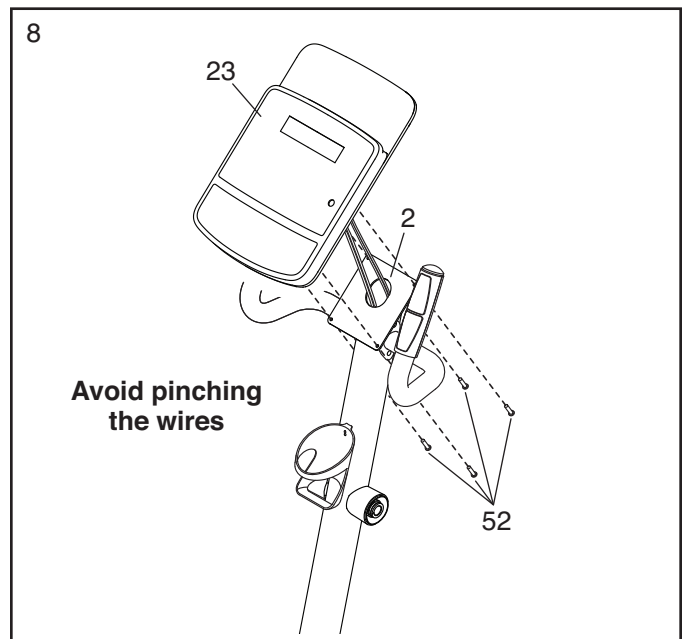

9. Identify the Right Upper Body Arm (8).

Slide an Upper Body Arm Cover (42) upward onto the Right Upper Body Arm (8).

Next, insert the Right Upper Body Arm (8) into an Upper Body Leg (5).

**Tip: Have a second person hold the Upper Body Arm Cover (42) while you perform this action:**

Attach the Right Upper Body Arm (8) to the Upper Body Leg (5) with three M8 x 41mm Bolts (50) and three M8 Jam Nuts (38). **Make sure that the Jam Nuts are inside the hexagonal holes (E).**

**Assemble the Left Upper Body Arm (6) and the other Upper Body Leg (5) in the same way.**

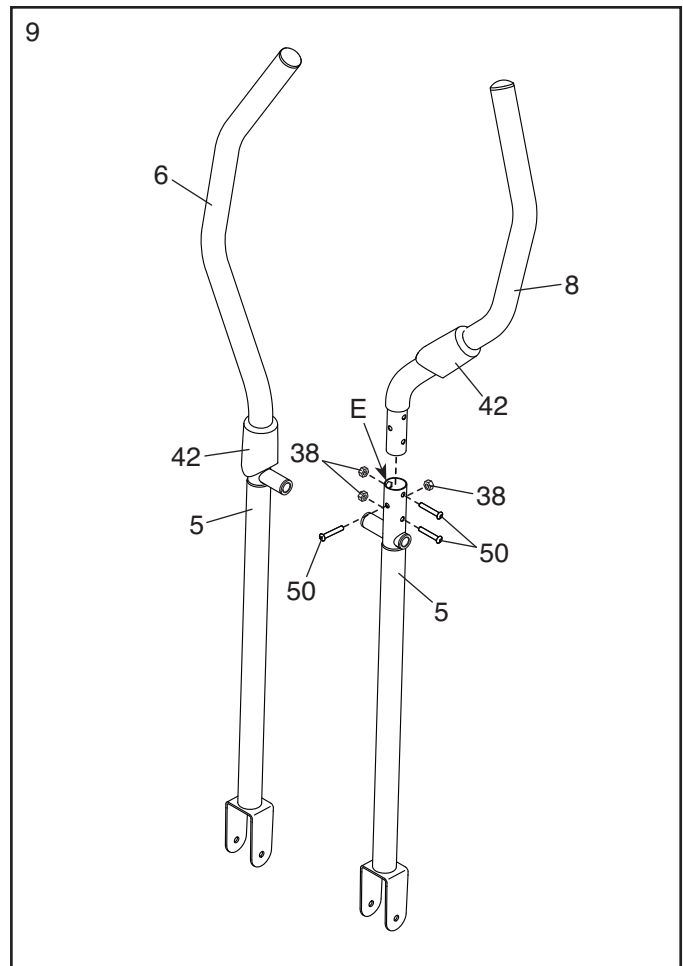

10. Insert the Pivot Axle (26) into the Upright (2), and center the Pivot Axle.

Using a small plastic bag to keep your fingers clean, apply a generous amount of the included grease to both ends of the Pivot Axle (26).

Then, slide a Pivot Spacer (69) onto each side of the Pivot Axle (26).

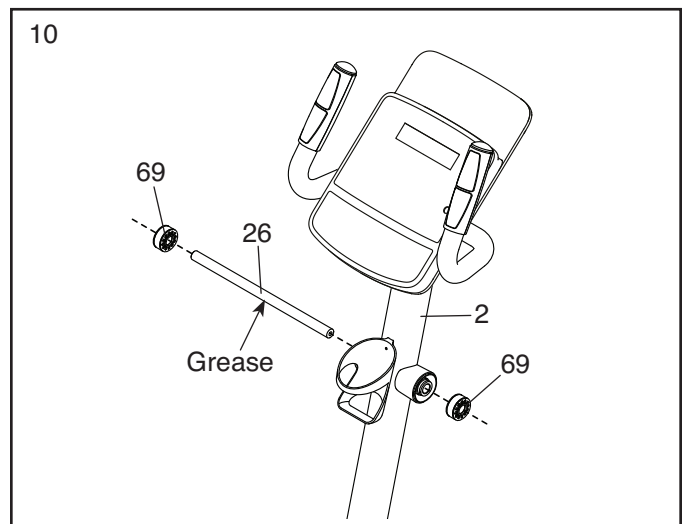

11. Orient an Upper Body Arm Spacer (47) as shown, and slide it onto the right side of the Pivot Axle (26).

Next, slide the Right Upper Body Arm (8) onto the right side of the Pivot Axle (26).

**Repeat these actions on the other side of the elliptical.**

Next, tighten an M8 x 25mm Screw (56) with an M8 Washer (55) into each end of the Pivot Axle (26) **at the same time.**

Next, slide the right Upper Body Arm Cover (42) upward. Then, press the tabs on an Axle Cap (46) into the Upper Body Arm Spacer (47). **Repeat this action on the other side of the elliptical.**

Then, slide the Upper Body Arm Cover (42) downward to cover the M8 x 41mm Bolts (not shown). **Repeat this action on the other side of the elliptical.**

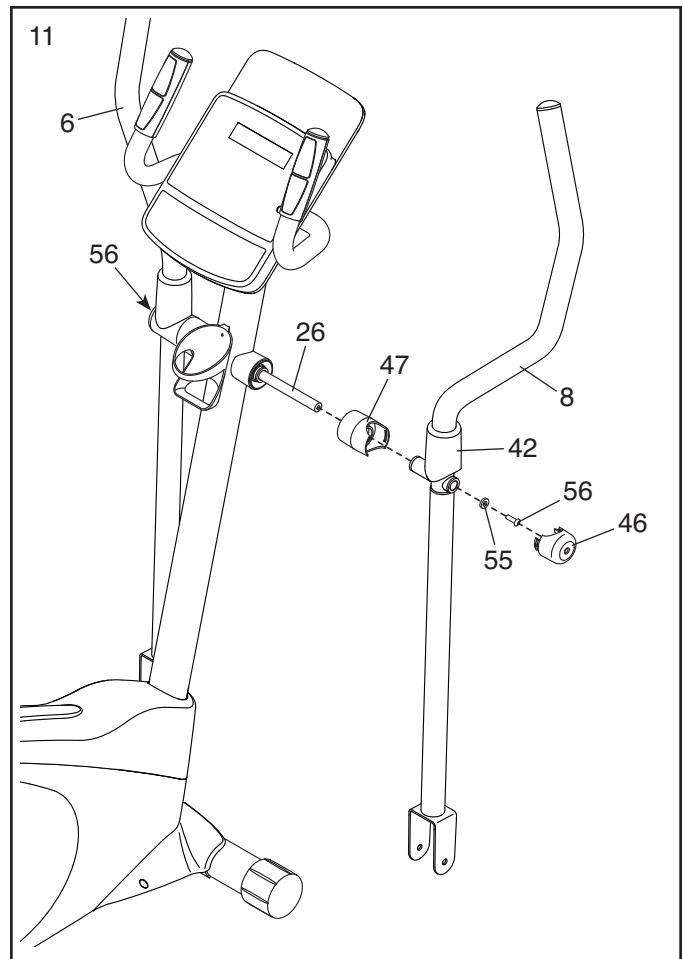

12. Identify the Right Pedal (14) and the Right Pedal Arm (12).

Attach the Right Pedal (14) to the Right Pedal Arm (12) with three M8 x 10mm Screws (27); **start all the Screws, and then tighten them.**

**Attach the Left Pedal (13) to the Left Pedal Arm (11) in the same way.**

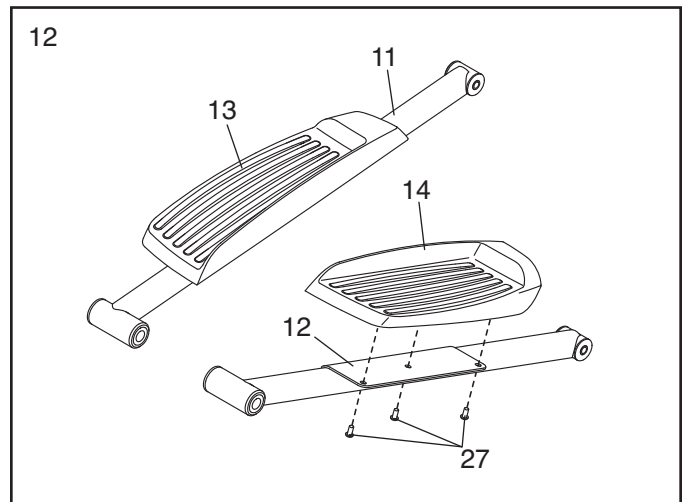

13. Orient a Crank Arm Stud (32) as shown, and tighten it firmly into the Right Crank Arm (80).  
**IMPORTANT: Make sure that the Crank Arm Stud is firmly tightened.**

Then, tighten an M6 x 8mm Set Screw (89) into the Right Crank Arm (80) and the Crank Arm Stud (32).

**Repeat this step on the other side of the elliptical.**

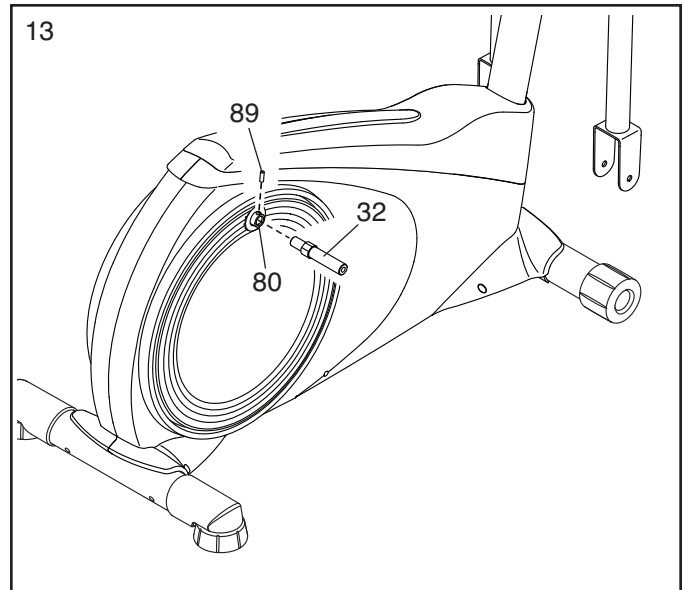

14. Apply a small amount of grease to the axle on the right Crank Arm Stud (32).

Slide the Right Pedal Arm (12) onto the axle on the right Crank Arm Stud (32).

Next, slide an M10 x 28mm Washer (83) onto an M10 x 20mm Screw (40), and tighten the Screw into the axle.

Then, press a Pedal Arm Cap (74) into the Right Pedal Arm (12).

**Repeat this step on the other side of the elliptical.**

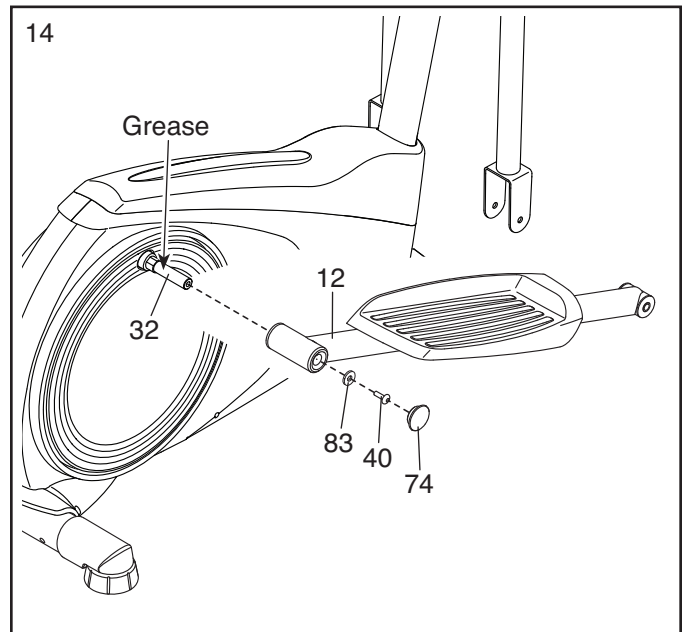

15. **See assembly steps 4 and 5.** Tighten the M10 x 20mm Screws (40) and the M10 Locknut (33). Then, press the Top Shield (41) into place.

Next, apply a small amount of grease to an M6 Bolt Set (25).

Hold the end of the Right Pedal Arm (12) inside the bracket on the right Upper Body Leg (5).

Attach the right Upper Body Leg (5) to the Right Pedal Arm (12) with the M6 Bolt Set (25).

**Repeat this step on the other side of the elliptical.**

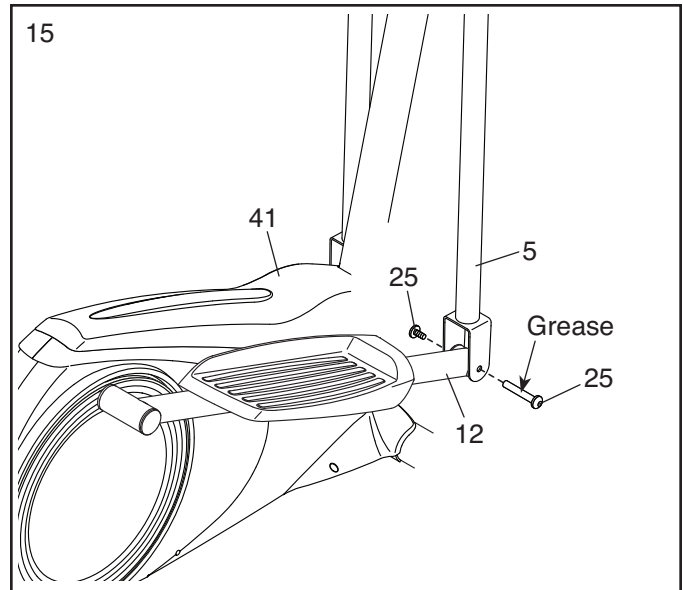

16. Plug the Power Adapter (75) into the receptacle on the front of the elliptical.

Note: To plug the Power Adapter (75) into an outlet, see HOW TO PLUG IN THE POWER ADAPTER on page 15.

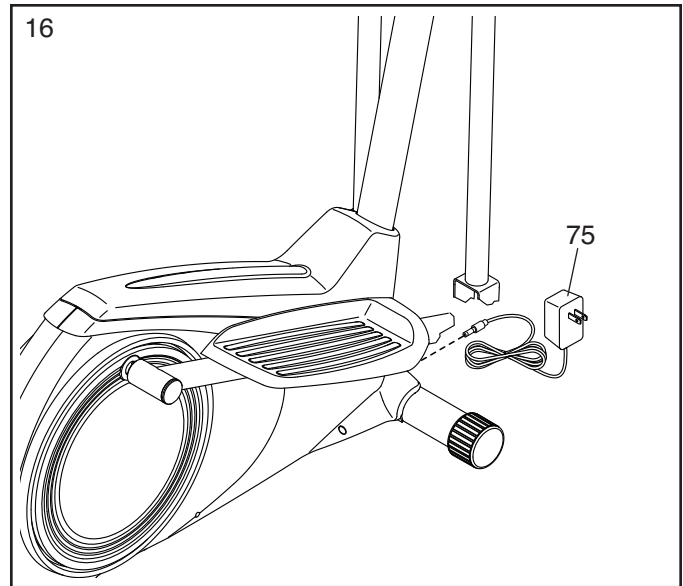

17. **Make sure that all parts are properly tightened.** Extra parts may be included. Place a mat beneath the elliptical to protect the floor.

# HOW TO USE THE ELLIPTICAL

## HOW TO PLUG IN THE POWER ADAPTER

**IMPORTANT:** If the elliptical has been exposed to cold temperatures, allow it to warm to room temperature before you plug in the power adapter (A). If you do not do this, you may damage the console displays or other electronic components.

Plug the power adapter (A) into the receptacle on the front of the elliptical. Then, plug the power adapter into an appropriate outlet that is properly installed in accordance with all local codes and ordinances.

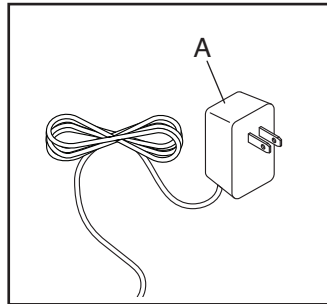

## HOW TO MOVE THE ELLIPTICAL

Due to the size and weight of the elliptical, moving it requires two persons. Stand in front of the elliptical, hold the upright (B), and place one foot against one of the front wheels (C). Next, pull on the upright and have a second person lift the rear stabilizer (D) until the elliptical will roll on the wheels. Carefully move the elliptical to the desired location, and then lower it to the floor.

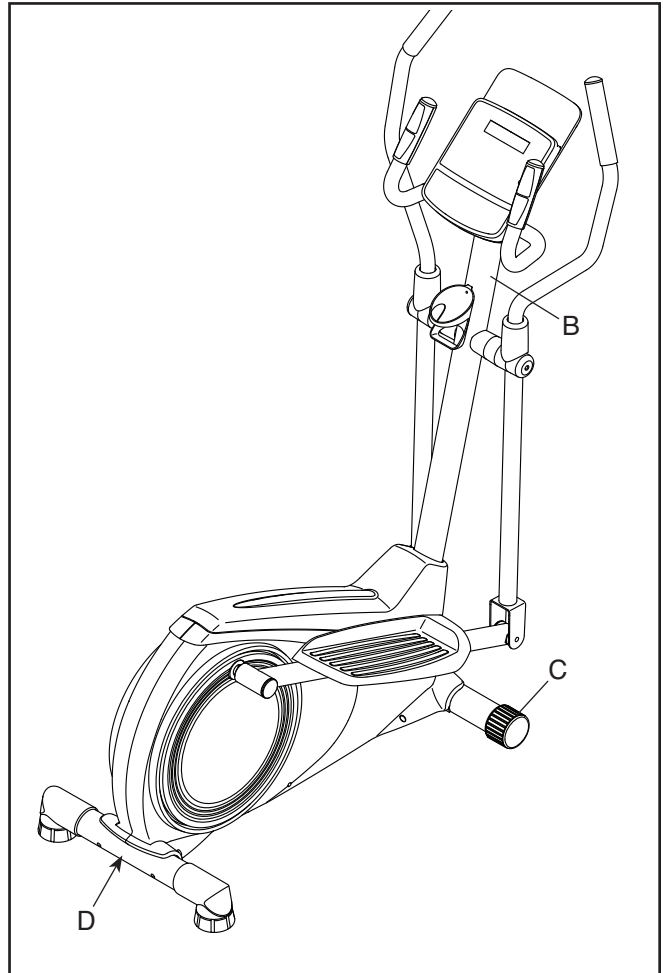

## HOW TO EXERCISE ON THE ELLIPTICAL

To mount the elliptical, hold the handlebars (E) or the upper body arms (F) and step onto the pedal (G) that is in the lowest position. Then, step onto the other pedal.

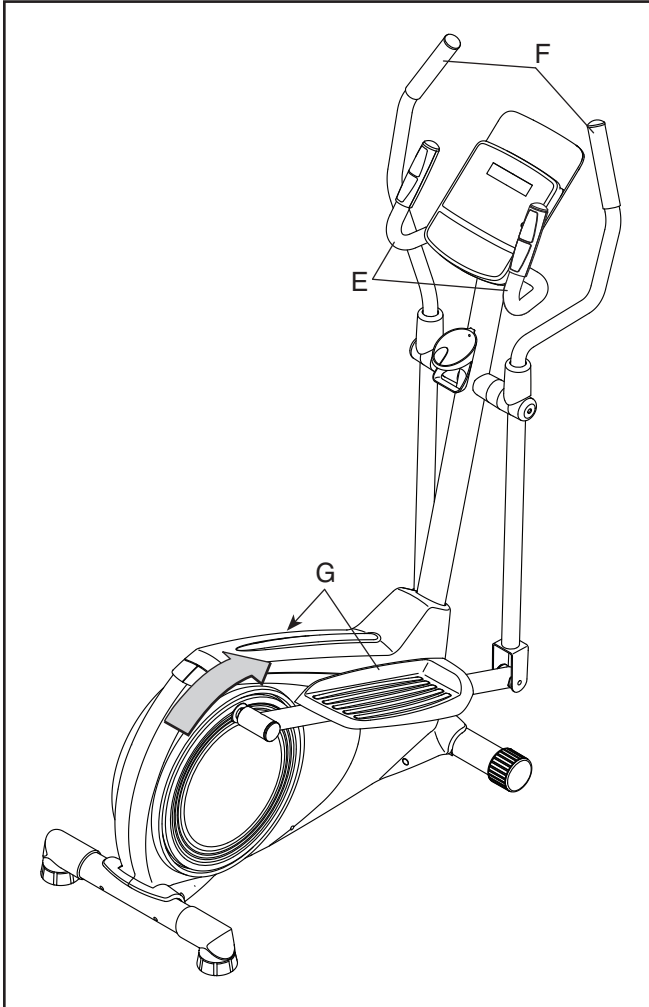

Push the pedals (G) until they begin to move with a continuous motion. **Note: The pedal discs can turn in either direction. It is recommended that you move the pedal discs in the direction shown by the arrow; however, for variety, you can turn the pedal discs in the opposite direction.**

To dismount the elliptical, wait until the pedals (G) come to a complete stop. **Note: The elliptical does not have a free wheel; the pedals will continue to move until the flywheel stops.** When the pedals are stationary, step off the higher pedal first. Then, step off the lower pedal.

## HOW TO LEVEL THE ELLIPTICAL

If the elliptical rocks slightly on your floor during use, turn one or both of the leveling feet (H) beneath the rear stabilizer until the rocking motion is eliminated.

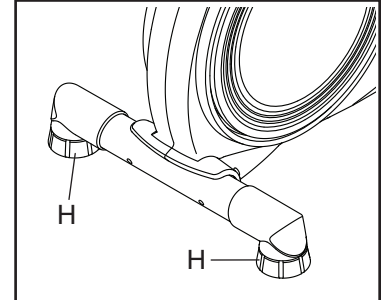

# HOW TO USE THE CONSOLE

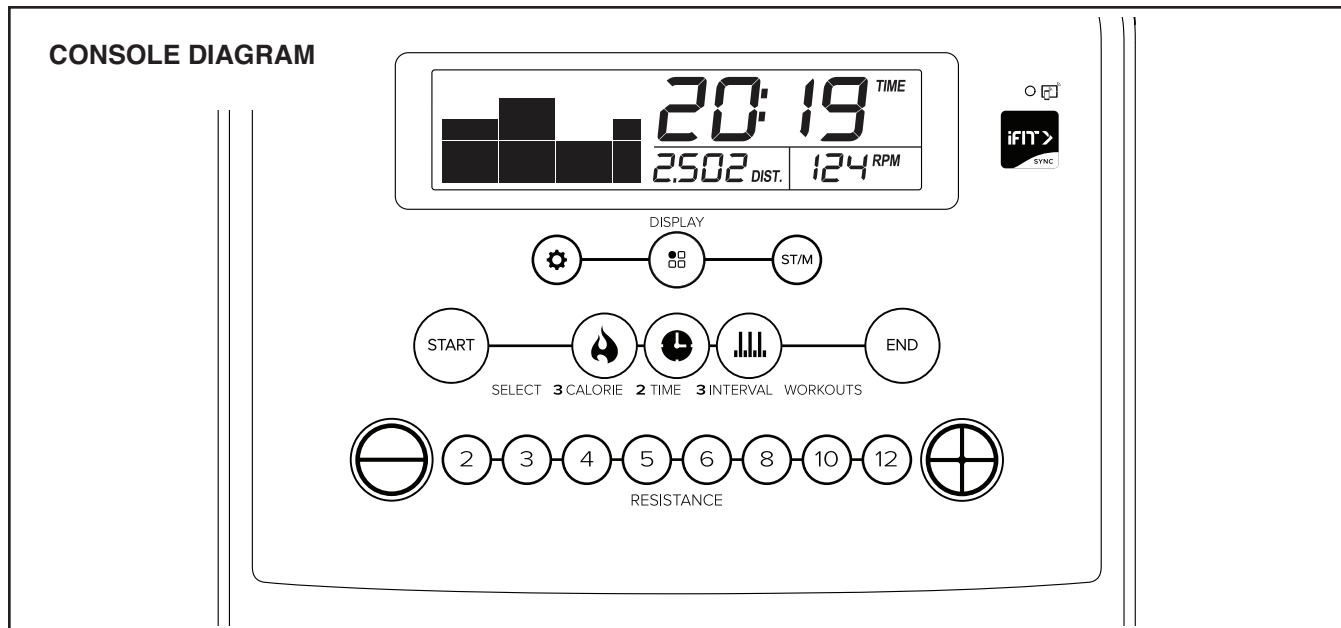

## FEATURES OF THE CONSOLE

The advanced console offers an array of features designed to make your workouts more effective and enjoyable.

When you use the manual mode of the console, you can change the resistance of the pedals with the touch of a button.

As you exercise, the console will provide continuous exercise feedback. You can even measure your heart rate using the handgrip heart rate monitor or a compatible heart rate monitor. **See page 22 for information about purchasing an optional chest heart rate monitor.**

You can also connect your tablet to the console and use the iFit app to record and track your workout information.

The console also offers a selection of onboard workouts. Each onboard workout automatically changes the resistance of the pedals and prompts you to maintain a target pedaling speed as it guides you through an effective workout.

**To use the manual mode**, see page 18. **To use an onboard workout**, see page 20. **To connect your tablet to the console**, see page 21. **To connect your heart rate monitor to the console**, see page 21. **To change console settings**, see page 22.

Note: If there is a sheet of plastic on the display, remove the plastic.

Note: The console can display speed and distance in either standard or metric units. To change the unit of measurement, press the St/M button repeatedly. For simplicity, all instructions in this section refer to standard units.

## HOW TO USE THE MANUAL MODE

### 1. Begin pedaling or press any button on the console to turn on the console.

When you turn on the console, the display will turn on. The console will then be ready for use.

### 2. Select the manual mode.

When you turn on the console, the manual mode will be selected automatically.

If you have selected a workout, reselect the manual mode by pressing any of the Workouts buttons repeatedly until zeros appear in the display.

### 3. Change the resistance of the pedals as desired.

Press the Start button or begin pedaling to start the manual mode.

As you pedal, you can change the resistance of the pedals. To change the resistance, press one of the numbered Resistance buttons or press the Resistance increase and decrease buttons.

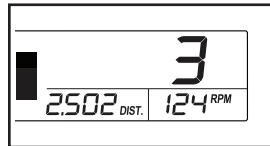

Note: After you press a button, it will take a moment for the pedals to reach the selected resistance level.

### 4. Follow your progress with the display.

The displays can show the following workout information:

**Calories (CALs.)**—When the manual mode and most onboard workouts are selected, the approximate number of calories you have burned. When calorie workouts are selected, the approximate number of calories that remain to be burned in the workout.

**Distance (DIST.)**—The distance that you have pedaled in miles or kilometers. To change the unit of measurement, press the St/M button.

**Heart Rate (heart symbol)**—Your heart rate when you use the handgrip heart rate monitor or a compatible heart rate monitor (see step 5).

**Matrix**—When the manual mode is selected, a track that represents 1/4 mile (400 m). As you exercise, the flashing rectangle will show your progress. When an onboard workout is selected, a profile of the resistance levels of the workout.

**Resistance Level**—The resistance level of the pedals.

**RPM**—Your pedaling speed in revolutions per minute (RPM).

**Speed**—Your pedaling speed in miles per hour or kilometers per hour. To change the unit of measurement, press the St/M button.

**Time**—When the manual mode or a calorie workout is selected, the elapsed time. When an onboard workout is selected, the time remaining in the workout.

Press the Display button repeatedly to view the desired workout information in the displays.

**Scan mode**—The console also has a scan mode that will display workout information in a repeating cycle. To turn on the scan mode, press the Display button repeatedly until the word SCAN appears in the display.

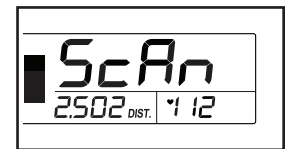

Note: The console will show your heart rate in the scan cycle automatically whenever it detects a pulse from a heart rate monitor.

To pause the console, simply stop pedaling or press the End button. When the console is paused, the time will flash in the display. To continue your workout, simply resume pedaling.

To end the workout, press the End button repeatedly.

Note: The console can show speed and distance in standard or metric units of measurement. To change the unit of measurement, press the St/M button.

## 5. Measure your heart rate if desired.

You can measure your heart rate using either the handgrip heart rate monitor or an optional chest heart rate monitor (see page 22 for information about the optional chest heart rate monitor).

Note: The console is compatible with Bluetooth® Smart heart rate monitors.

**Note: If you use both heart rate monitors at the same time, the Bluetooth Smart heart rate monitor will have priority.**

**If there are sheets of plastic on the metal contacts (A) on the handgrip heart rate monitor, remove the plastic. To measure your heart rate, hold the handgrip heart rate monitor with your**

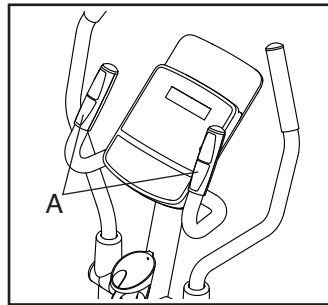

palms resting against the contacts. Avoid moving your hands or gripping the contacts tightly.

When your pulse is detected, your heart rate will be shown in the display. **For the most accurate heart rate reading, hold the contacts for at least 15 seconds.**

If the display does not show your heart rate, make sure that your hands are positioned as described. Be careful not to move your hands excessively or to squeeze the contacts tightly. For optimal performance, clean the contacts using a soft cloth; **never use alcohol, abrasives, or chemicals to clean the contacts.**

## 6. When you are finished exercising, the console will turn off automatically.

If the pedals do not move for several seconds, the console will pause and the time will flash in the display. To resume your workout, simply resume pedaling.

If the pedals do not move for several minutes and the buttons are not pressed, the console will turn off and the display will be reset.

Note: The console features a demo mode, designed to be used if the elliptical is displayed in a store. If the demo mode is turned on, the console will not turn off and the display will not be reset when you finish exercising. To turn off the demo mode, see HOW TO CHANGE CONSOLE SETTINGS on page 22.

## HOW TO USE AN ONBOARD WORKOUT

1. **Begin pedaling or press any button on the console to turn on the console.**

When you turn on the console, the display will turn on. The console will then be ready for use.

2. **Select an onboard workout.**

To select an onboard workout, press the Calorie, Time, or Interval Workouts button repeatedly until the name of the desired workout appears in the display.

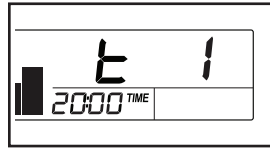

A few seconds after you press a button, the duration of the workout or the number of calories to be burned will appear in the display. The maximum pedaling speed may also appear.

3. **Start the workout.**

Press the Start button or begin pedaling to start the workout.

**Calorie and Interval Workouts**—Each Calorie and Interval workout is divided into segments. One resistance level and one target speed are programmed for each segment. Note: The same resistance level and/or target speed may be programmed for consecutive segments.

If a different resistance level is programmed for the next segment, the resistance level will appear in the display for a few seconds to alert you. The resistance of the pedals will then change.

As you exercise, you will be prompted to keep your pedaling speed near the target speed for the current segment.



**When the words TOO SLO appear in the display**, increase your pedaling speed. **When the words TOO FAST appear**, decrease your pedaling speed. **When no words appear**, maintain your current pedaling speed.

**IMPORTANT: The target speed is intended only to provide motivation. Your actual pedaling speed may be slower than the target speed. Make sure to pedal at a speed that is comfortable for you.**

If the resistance level for the current segment is too high or too low, you can manually override the setting by pressing the Resistance buttons.

**IMPORTANT: When the current segment of the workout ends, the pedals will automatically adjust to the resistance level programmed for the next segment.**

The workout will continue in this way until the last segment ends. To pause the console, simply stop pedaling or press the End button. When the console is paused, the time will flash in the display. To continue your workout, simply resume pedaling.

To end the workout, press the End button repeatedly.

**Time Workouts**—Each Time workout is divided into segments. Adjust the resistance level and your pedaling speed as desired during each segment of a Time workout.

The workout will continue in this way until the last segment ends. To pause the console, simply stop pedaling or press the End button. When the console is paused, the time will flash in the display. To continue your workout, simply resume pedaling.

To end the workout, press the End button repeatedly.

4. **Follow your progress with the display.**

See step 4 on page 18.

5. **Measure your heart rate if desired.**

See step 5 on page 19.

6. **When you are finished exercising, the console will turn off automatically.**

See step 6 on page 19.

## HOW TO CONNECT YOUR TABLET TO THE CONSOLE

The console supports Bluetooth connections to tablets via the iFit app and to compatible heart rate monitors. Note: Other Bluetooth connections are not supported.

### 1. Download and install the iFit app on your tablet.

On your iOS® or Android™ tablet, open the App Store<sup>SM</sup> or the Google Play™ store, search for the free iFit app, and then install the app on your tablet. **Make sure that the Bluetooth option is enabled on your tablet.**

Then, open the iFit app and follow the instructions to set up an iFit account and customize settings.

### 2. Connect your heart rate monitor to the console if desired.

If you are connecting both your heart rate monitor and your tablet to the console, **you must connect your heart rate monitor before you connect your tablet.** See HOW TO CONNECT YOUR HEART RATE MONITOR TO THE CONSOLE at the right.

### 3. Connect your tablet to the console.

Press the iFit Sync button on the console; the console pairing number will appear in the display. Then, follow the instructions in the iFit app to connect your tablet to the console.

When a connection is established, the LED on the console will turn solid blue.

### 4. Record and track your workout information.

Follow the instructions in the iFit app to record and track your workout information.

### 5. Disconnect your tablet from the console if desired.

To disconnect your tablet from the console, first select the disconnect option in the iFit app. Then, press and hold the iFit Sync button on the console until the LED on the console turns solid green.

Note: All Bluetooth connections between the console and other devices (including any tablets, heart rate monitors, and so forth) will be disconnected.

## HOW TO CONNECT YOUR HEART RATE MONITOR TO THE CONSOLE

The console is compatible with all Bluetooth Smart heart rate monitors.

To connect your Bluetooth Smart heart rate monitor to the console, press the iFit Sync button on the console; the console pairing number will appear in the display. When a connection is established, the LED on the console will flash red twice.

Note: If there is more than one compatible heart rate monitor near the console, the console will connect to the heart rate monitor with the strongest signal.

To disconnect your heart rate monitor from the console, press and hold the iFit Sync button on the console until the LED on the console turns solid green.

Note: All Bluetooth connections between the console and other devices (including any tablets, heart rate monitors, and so forth) will be disconnected.

## HOW TO CHANGE CONSOLE SETTINGS

### 1. Select the settings mode.

To select the settings mode, press the Settings button (gear symbol). The first settings screen will appear in the display.

### 2. Navigate the settings mode.

While the settings mode is selected, you can navigate through several settings screens. Press the Display button repeatedly to select the desired settings screen.

### 3. Change settings as desired.

**Software Version Number**—The software version number will appear in the display.

#### **Unit of Measurement**—

The currently selected unit of measurement will appear in the display. The console can show speed and distance in standard or metric units of measurement. To change the unit of measurement, press the St/M button repeatedly. To view workout information in standard units, select STD. To view workout information in metric units, select MET.

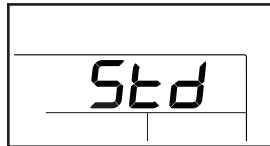

**Display Test**—This screen is intended to be used by service technicians to identify whether the display is working correctly.

**Button Test**—This screen is intended to be used by service technicians to identify whether a certain button is working correctly.

#### **Total Time and Total**

**Distance**—The display will show the total number of hours that the elliptical has been used and the total distance (in miles or kilometers) that the elliptical has been pedaled.

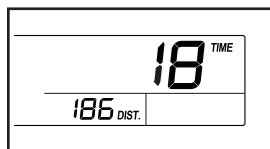

**Demo Mode**—The currently selected demo mode option will appear in the display. The console features a demo mode, designed to be used if the elliptical is displayed in a store. If the demo mode is turned on, the console will not turn off and the display will not be reset when you finish exercising. Press the Resistance increase button repeatedly to select a demo mode option. To turn on the demo mode, select DON. To turn off the demo mode, select DOFF.



### 4. Exit the settings mode.

Press the Settings button (gear symbol) to exit the settings mode.

## THE OPTIONAL CHEST HEART RATE MONITOR

Whether your goal is to burn fat or to strengthen your cardiovascular system, the key to achieving the best results is to maintain the proper heart rate during your workouts.

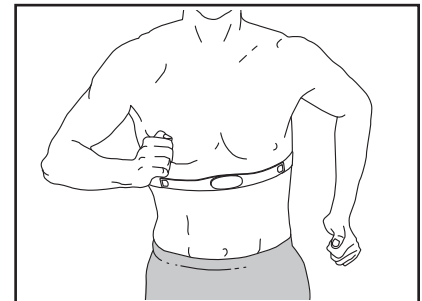

The optional chest heart rate monitor will enable you to continuously monitor your heart rate while you exercise, helping you to reach your personal fitness goals. **To purchase a chest heart rate monitor, please see the front cover of this manual.**

Note: The console is compatible with all Bluetooth Smart heart rate monitors.

---

## FCC INFORMATION

This equipment has been tested and found to comply with the limits for a Class B digital device, pursuant to Part 15 of the FCC Rules. These limits are designed to provide reasonable protection against harmful interference in a residential installation. This equipment generates, uses, and can radiate radio frequency energy and, if not installed and used in accordance with the instructions, may cause harmful interference to radio communications. However, there is no guarantee that interference will not occur in a particular installation. If this equipment does cause harmful interference to radio or television reception, which can be determined by turning the equipment off and on, try to correct the interference by one or more of the following measures:

- Reorient or relocate the receiving antenna.
- Increase the separation between the equipment and the receiver.
- Connect the equipment into an outlet on a circuit different from that to which the receiver is connected.
- Consult the dealer or an experienced radio/TV technician for help.

**FCC CAUTION: To assure continued compliance, use only shielded interface cables when connecting to computer or peripheral devices. Changes or modifications not expressly approved by the party responsible for compliance could void the user's authority to operate this equipment.**

**IMPORTANT: To satisfy exposure compliance requirements, the antenna and transmitter in the console must be at least 8 in. (20 cm) from all persons and must not be near or connected to any other antenna or transmitter.**

**Note: The console contains FCC ID: OMCBMD1.**

# MAINTENANCE AND TROUBLESHOOTING

## MAINTENANCE

Regular maintenance is important for optimal performance and to reduce wear. Inspect and properly tighten all parts each time the elliptical is used. Replace any worn parts immediately.

To clean the elliptical, use a damp cloth and a small amount of mild dish soap. **IMPORTANT: Keep liquids away from the console and keep the console out of direct sunlight.**

## CONSOLE TROUBLESHOOTING

If the handgrip heart rate monitor does not function properly, see step 5 on page 19.

**If a replacement power adapter is needed, call the telephone number on the cover of this manual. IMPORTANT: To avoid damaging the console, use only a manufacturer-supplied regulated power adapter.**

## HOW TO ADJUST THE REED SWITCH

If the console does not display correct feedback, the reed switch should be adjusted.

Using a standard screwdriver, remove the Top Shield (41).

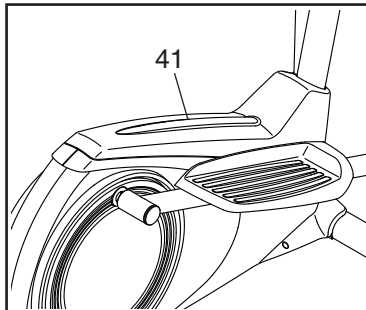

Note: For clarity, the right pedal disc is not shown in the drawing below.

Locate the Reed Switch (53). Slightly loosen the M4 x 16mm Screw (52).

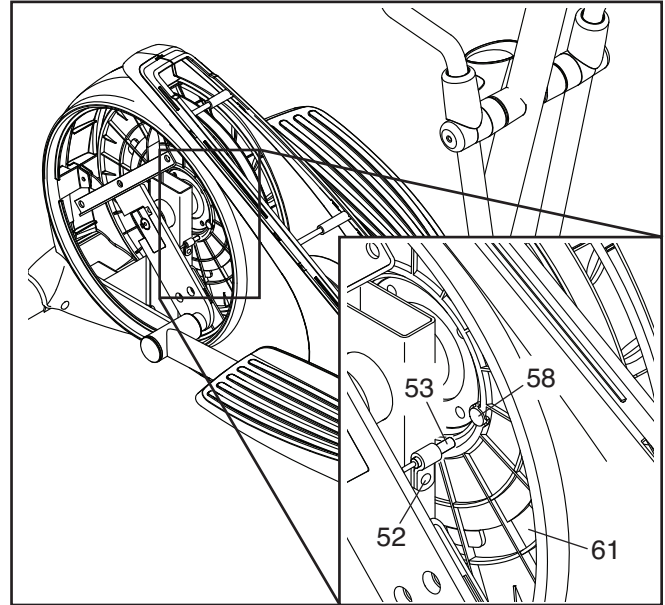

Next, rotate the Pulley (61) until a Magnet (58) is aligned with the Reed Switch (53). Slide the Reed Switch slightly toward or away from the Magnet. Then, retighten the M4 x 16mm Screw (52). Rotate the Pulley for a moment.

Repeat these actions until the console displays correct feedback.

When the reed switch is correctly adjusted, reattach the top shield.

## HOW TO ADJUST THE DRIVE BELT

If you feel the pedals slip while you are pedaling, even when the resistance is adjusted to the highest level, the drive belt may need to be adjusted.

To adjust the drive belt, you must remove the pedal arms, the pedal discs, and the left shield.

**See step 14 on page 13 and step 15 on page 14.** Remove the Left and Right Pedal Arms (11, 12).

**See EXPLODED DRAWING A on page 30.** Using a standard screwdriver, remove the left and right Pedal Discs (15).

Next, identify the Left and Right Shields (3, 4). Remove all of the M4 x 16mm Screws (52) from the Left and Right Shields.

Next, remove the two M6 x 18mm Screws (43). Then, remove the Left Shield (3).

Next, loosen the M8 x 22mm Screw (65), and turn the M10 x 60mm Bolt (62) until the Drive Belt (19) is tight.

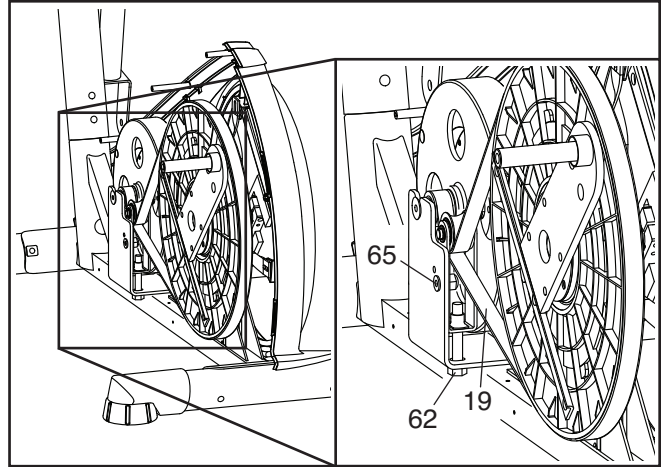

When the Drive Belt (19) is tight, tighten the M8 x 22mm Screw (65).

Then, reattach the shields, the pedal discs, and the pedal arms.

# EXERCISE GUIDELINES

**⚠️ WARNING:** Before beginning this or any exercise program, consult your physician. This is especially important for persons over age 35 or persons with pre-existing health problems.

The heart rate monitor is not a medical device. Various factors may affect the accuracy of heart rate readings. The heart rate monitor is intended only as an exercise aid in determining heart rate trends in general.

These guidelines will help you to plan your exercise program. For detailed exercise information, obtain a reputable book or consult your physician. Remember, proper nutrition and adequate rest are essential for successful results.

## EXERCISE INTENSITY

Whether your goal is to burn fat or to strengthen your cardiovascular system, exercising at the proper intensity is the key to achieving results. You can use your heart rate as a guide to find the proper intensity level. The chart below shows recommended heart rates for fat burning and aerobic exercise.

165	155	145	140	130	125	115	♥♥
145	138	130	125	118	110	103	♥
125	120	115	110	105	95	90	♥
<hr/>							
20	30	40	50	60	70	80	

To find the proper intensity level, find your age at the bottom of the chart (ages are rounded off to the nearest ten years). The three numbers listed above your age define your “training zone.” The lowest number is the heart rate for fat burning, the middle number is the heart rate for maximum fat burning, and the highest number is the heart rate for aerobic exercise.

**Burning Fat**—To burn fat effectively, you must exercise at a low intensity level for a sustained period of time. During the first few minutes of exercise, your body uses carbohydrate calories for energy. Only after the first few minutes of exercise does your body begin to use stored fat calories for energy. If your goal is to burn fat, adjust the intensity of your exercise until your heart rate is near the lowest number in your training zone. For maximum fat burning, exercise with your heart rate near the middle number in your training zone.

**Aerobic Exercise**—If your goal is to strengthen your cardiovascular system, you must perform aerobic exercise, which is activity that requires large amounts of oxygen for prolonged periods of time. For aerobic exercise, adjust the intensity of your exercise until your heart rate is near the highest number in your training zone.

## WORKOUT GUIDELINES

**Warming Up**—Start with 5 to 10 minutes of stretching and light exercise. A warm-up increases your body temperature, heart rate, and circulation in preparation for exercise.

**Training Zone Exercise**—Exercise for 20 to 30 minutes with your heart rate in your training zone. (During the first few weeks of your exercise program, do not keep your heart rate in your training zone for longer than 20 minutes.) Breathe regularly and deeply as you exercise; never hold your breath.

**Cooling Down**—Finish with 5 to 10 minutes of stretching. Stretching increases the flexibility of your muscles and helps to prevent post-exercise problems.

## EXERCISE FREQUENCY

To maintain or improve your condition, complete three workouts each week, with at least one day of rest between workouts. After a few months of regular exercise, you may complete up to five workouts each week, if desired. Remember, the key to success is to make exercise a regular and enjoyable part of your everyday life.

## SUGGESTED STRETCHES

The correct form for several basic stretches is shown at the right. Move slowly as you stretch; never bounce.

### 1. Toe Touch Stretch

Stand with your knees bent slightly and slowly bend forward from your hips. Allow your back and shoulders to relax as you reach down toward your toes as far as possible. Hold for 15 counts, then relax. Repeat 3 times. Stretches: Hamstrings, back of knees and back.

### 2. Hamstring Stretch

Sit with one leg extended. Bring the sole of the opposite foot toward you and rest it against the inner thigh of your extended leg. Reach toward your toes as far as possible. Hold for 15 counts, then relax. Repeat 3 times for each leg. Stretches: Hamstrings, lower back and groin.

### 3. Calf/Achilles Stretch

With one leg in front of the other, reach forward and place your hands against a wall. Keep your back leg straight and your back foot flat on the floor. Bend your front leg, lean forward and move your hips toward the wall. Hold for 15 counts, then relax. Repeat 3 times for each leg. To cause further stretching of the achilles tendons, bend your back leg as well. Stretches: Calves, achilles tendons and ankles.

### 4. Quadriceps Stretch

With one hand against a wall for balance, reach back and grasp one foot with your other hand. Bring your heel as close to your buttocks as possible. Hold for 15 counts, then relax. Repeat 3 times for each leg. Stretches: Quadriceps and hip muscles.

### 5. Inner Thigh Stretch

Sit with the soles of your feet together and your knees outward. Pull your feet toward your groin area as far as possible. Hold for 15 counts, then relax. Repeat 3 times. Stretches: Quadriceps and hip muscles.

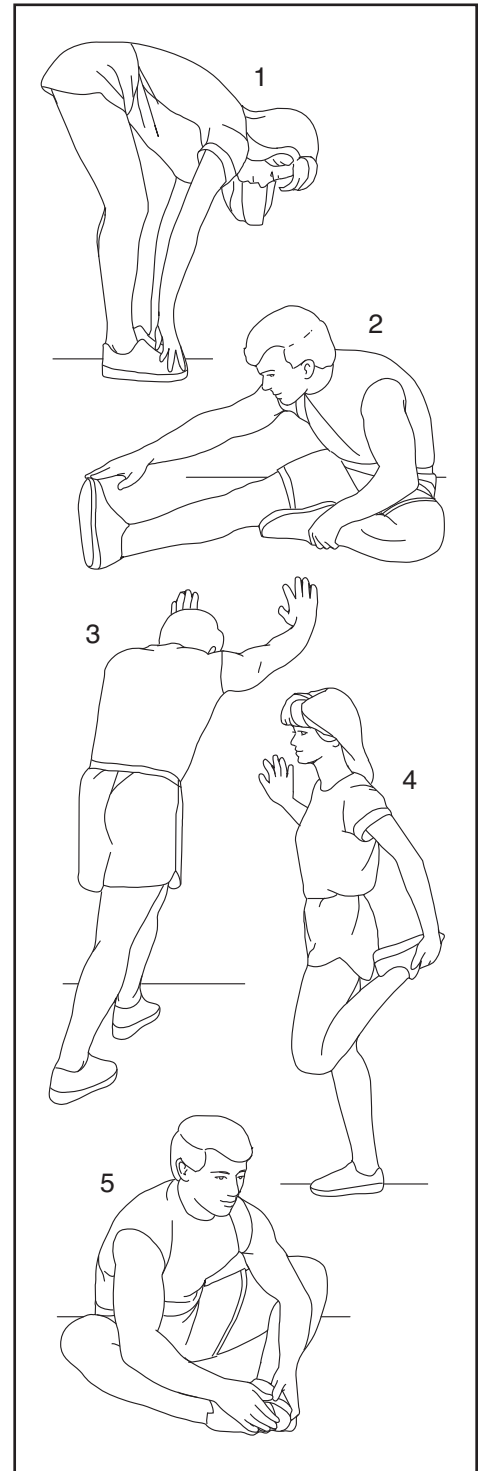

---

# NOTES

# PART LIST

Model No. PFEL02920.0 R0121A

Key No.	Qty.	Description	Key No.	Qty.	Description
1	1	Frame	47	2	Upper Body Arm Spacer
2	1	Upright	48	2	Frame Spacer
3	1	Left Shield	49	6	Upper Body Arm Bushing
4	1	Right Shield	50	6	M8 x 41mm Bolt
5	2	Upper Body Leg	51	4	M10 x 22mm Washer
6	1	Left Upper Body Arm	52	26	M4 x 16mm Screw
7	1	M10 x 77mm Bolt	53	1	Reed Switch/Wire
8	1	Right Upper Body Arm	54	1	Clamp
9	1	Rear Stabilizer	55	3	M8 Washer
10	1	Key	56	2	M8 x 25mm Screw
11	1	Left Pedal Arm	57	1	Mechanism Axle
12	1	Right Pedal Arm	58	2	Magnet
13	1	Left Pedal	59	2	Wiring Clamp
14	1	Right Pedal	60	4	Front Pedal Arm Bushing
15	2	Pedal Disc	61	1	Pulley
16	1	Left Crank Arm	62	1	M10 x 60mm Bolt
17	1	Eddy Mechanism	63	1	Front Stabilizer
18	1	Shield Bracket	64	8	Mushroom Fastener
19	1	Drive Belt	65	1	M8 x 22mm Screw
20	2	Rear Stabilizer Cap	66	2	M6 Locknut
21	2	Wheel	67	2	M10 Thin Locknut
22	1	Idler	68	1	Right Crank Spacer
23	1	Console	69	2	Pivot Spacer
24	2	Foam Grip	70	2	Leveling Foot
25	2	M6 Bolt Set	71	1	M8 Locknut
26	1	Pivot Axle	72	1	Resistance Motor
27	6	M8 x 10mm Screw	73	1	Wire Harness
28	1	M6 Washer	74	2	Pedal Arm Cap
29	1	Water Bottle Holder	75	1	Power Adapter
30	1	Left Crank Spacer	76	4	M8 x 10mm Hex Screw
31	2	Bearing	77	1	Resistance Cable
32	2	Crank Arm Stud	78	1	M4 x 16mm Bright Screw
33	1	M10 Locknut	79	2	M8 x 77mm Bolt
34	4	M10 x 68mm Screw	80	1	Right Crank Arm
35	1	M10 x 45mm Screw	81	1	Power Wire/Receptacle
36	2	M3 x 16mm Screw	82	1	Wire Bushing
37	2	Outer Pedal Arm Bushing	83	2	M10 x 28mm Washer
38	8	M8 Jam Nut	84	2	Pulse Wire
39	2	Inner Pedal Arm Bushing	85	1	Left Handlebar
40	6	M10 x 20mm Screw	86	1	Right Handlebar
41	1	Top Shield	87	2	Pulse Grip
42	2	Upper Body Arm Cover	88	1	M10 Curved Washer
43	2	M6 x 18mm Screw	89	2	M6 x 8mm Set Screw
44	2	Small Upper Body Arm Cap	*	–	Assembly Tool
45	1	M6 x 14mm Screw	*	–	Grease Packet
46	2	Axle Cap	*	–	User's Manual

Note: Specifications are subject to change without notice. For information about ordering replacement parts, see the back cover of this manual. \*These parts are not illustrated.



# EXPLODED DRAWING B

Model No. PFEL02920.0 R0121A

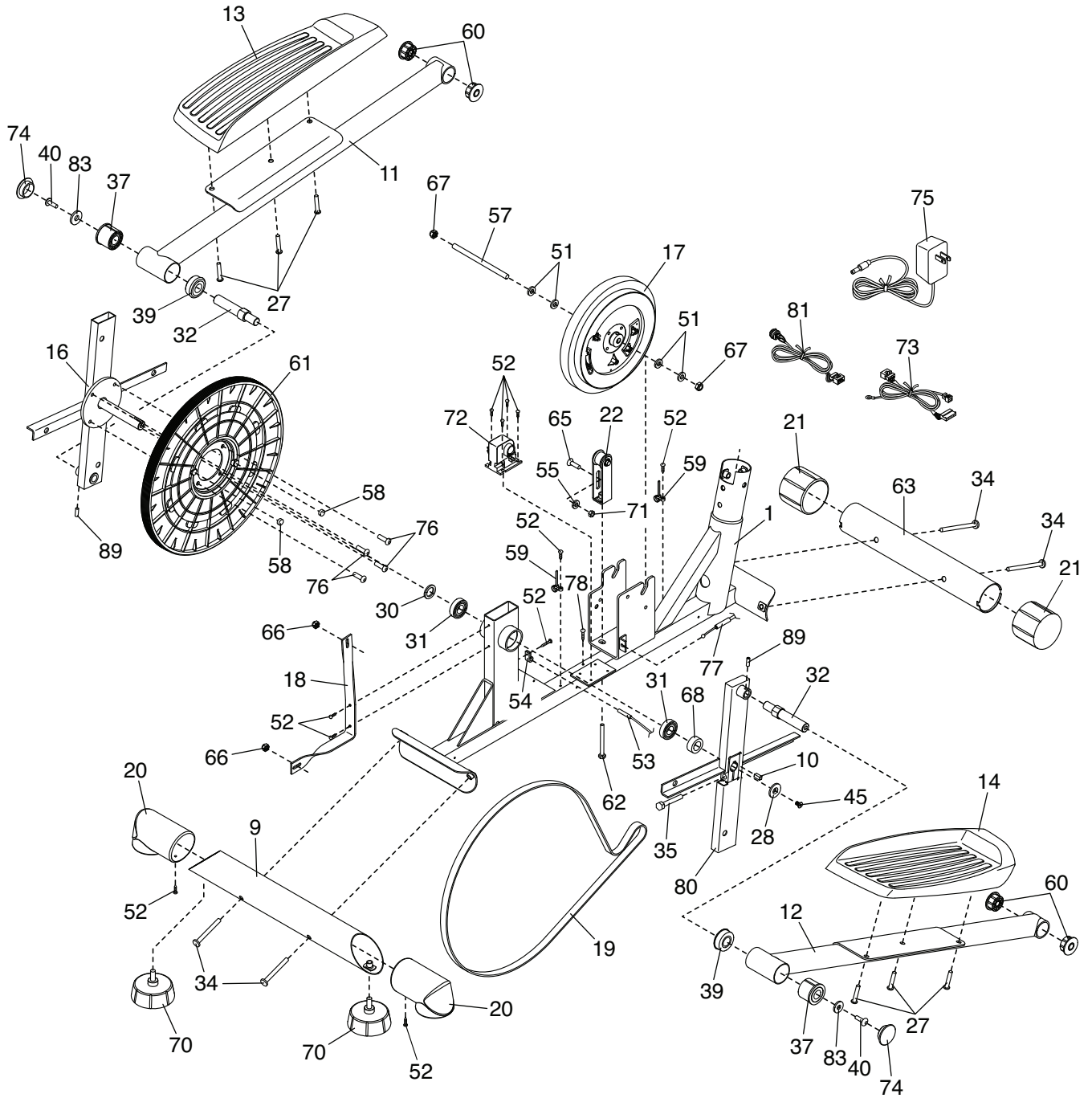

---

# ORDERING REPLACEMENT PARTS

To order replacement parts, please see the front cover of this manual. To help us assist you, be prepared to provide the following information when contacting us:

- the model number and serial number of the product (see the front cover of this manual)
- the name of the product (see the front cover of this manual)
- the key number and description of the replacement part(s) (see the PART LIST and the EXPLODED DRAWING near the end of this manual)

## LIMITED WARRANTY

**IMPORTANT: To protect your fitness equipment with an extended service plan, see page 4.**

ICON Health & Fitness, Inc. (ICON) warrants this product to be free from defects in workmanship and material, under normal use and service conditions. Parts and labor are warranted for ninety (90) days from the date of purchase.

This warranty extends only to the original purchaser (customer) and is not transferrable. ICON's obligation under this warranty is limited to repairing or replacing, at ICON's option, the product through one of its authorized service providers. All repairs for which warranty claims are made must be preauthorized by ICON. If replacement parts are shipped while the product is under warranty, the customer will be responsible for a minimal handling charge. For in-home service, the customer may be responsible for a minimal trip charge. This warranty does not extend to freight damage to the product. This warranty will automatically be voided by the following conditions: (1) if the product is used as a store display model, (2) if the product is purchased or transported outside the USA, (3) if all instructions and warnings in this manual are not followed, (4) if the product is abused or improperly or abnormally used, or (5) if the product is used for commercial or rental purposes. No other warranty beyond that specifically set forth above is authorized by ICON.

ICON is not responsible or liable for the following damages: (1) indirect, special, or consequential damages arising out of or in connection with the use or performance of the product; (2) damages with respect to any economic loss, loss of property, loss of revenues or profits, loss of enjoyment or use, or costs of removal or installation; or (3) other consequential damages of any kind. Some states do not allow the exclusion or limitation of incidental or consequential damages. Accordingly, the above limitation may not apply to the customer.

The warranty extended hereunder is in lieu of any and all other warranties, and any implied warranties of merchantability or fitness for a particular purpose are limited in their scope and duration to the terms set forth herein. Some states do not allow limitations on how long an implied warranty lasts. Accordingly, the above limitation may not apply to the customer. This warranty provides specific legal rights; the customer may have other rights that vary from state to state.

For warranty service, please call the telephone number on the front cover of this manual. Please be prepared to provide the model number and serial number of the product (see the front cover of this manual).

**ICON Health & Fitness, Inc., 1500 S. 1000 W., Logan, UT 84321-9813**