

### SPECIFICATIONS

### CX18



### FEATURES

- Deep Locking Cup For Easy Installation
- Stainless Steel Body
- Stainless Steel Basket
- Zinc Post With Ball Bearing Type Snap In Feature

### CARACTÉRISTIQUES

- Crépine-filtre profonde pour installation facile
- Fabriqué en acier inoxydable
- Panier en acier inoxydable
- Tenon en zinc avec attache-pression style roulement à billes

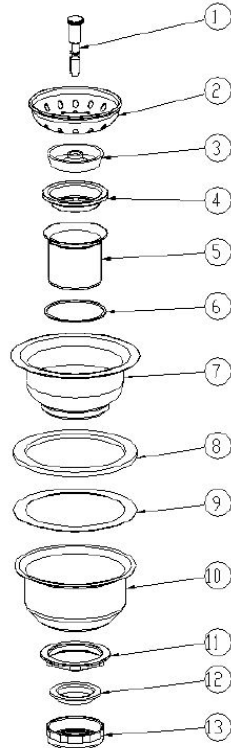
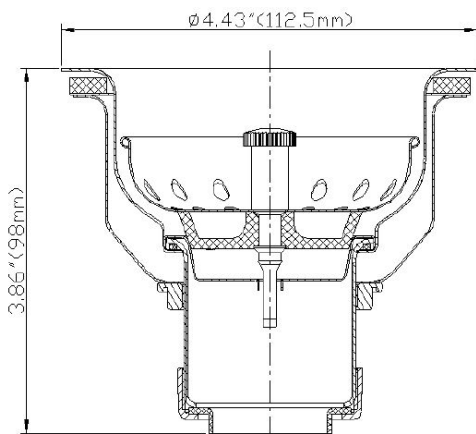

#	Part/ No de pièce	Material/ Matériel
1	Stick Post/ Colonne de manipulation	Zinc
2	Basket/ Panier	Stainless Steel/ Acier inoxydable
3	Stopper/ Arrêt	Rubber/ Caoutchouc
4	Gasket/ Joint d'étanchéité	Stainless Steel/ Acier inoxydable
5	Thread Tube/ Tuyau bridé	Stainless Steel/ Acier inoxydable
6	Washer/ Rondelle	Rubber/ Caoutchouc
7	Body/ Composant	Stainless Steel/ Acier inoxydable
8	Washer/ Rondelle	Rubber/ Caoutchouc
9	Friction Washer/ Rondelle de friction	Paper/ Papier
10	Shell/ Coquille	Stainless Steel/ Acier inoxydable
11	Locknut/ Écrou autofreiné	Zinc
12	Washer/ Rondelle	PE
13	Tailpiece Nut/ Écrou de raccordement	Zinc

#### AVAILABLE FINISHES / FINIS OFFERTS :

- Polished Chrome / Chrome poli (CP)