



EAGLES NEST ELITE SWING SET

Model # 1902329 | Owner's Manual & Assembly Instructions

MANUFACTURED BY:
Backyard Discovery
3305 Airport Drive
Pittsburg, KS 66762
800-856-4445



INSTALLATION SERVICES AVAILABLE!*

Need a helping hand?

Let our team of professionals handle the installation for you!

GOCONFIGURE
888-888-5424

*Installation services are only available to U.S. customers.

average 2 person assembly time



assembly time may vary based on skill level

Before you begin

FOR QUICK & EASY ASSEMBLY

FIND 3D INSTRUCTIONS FOR THIS PRODUCT IN

BILT.

DOWNLOAD THE FREE APP



For the most up to date assembly manual, to register your set, or to order replacement parts please visit

www.backyarddiscovery.com

SAVE THIS ASSEMBLY MANUAL FOR FUTURE REFERENCE IN THE EVENT THAT YOU NEED TO ORDER REPLACEMENT PARTS.

Para obtener instrucciones en español, visite www.backyarddiscovery.com



GOCONFIGURE
Putting it all together for you

INSTALLATION SERVICES AVAILABLE!*

Need a helping hand?

Let our team of professionals handle the installation for you!

GOCONFIGURE
888-888-5424

**Installation services are only available
to U.S. customers.*

With Go Configure, we bring you 18 years of experience right to your doorstep. We service a wide array of indoor and outdoor recreation products that most consumers don't have the time or ability to deliver & install themselves.

We do the heavy lifting, so you don't have to!

- 18+ Years of Experience Servicing Big Box Retailers and Direct Consumers
- Highly Skilled, Specialized, Courteous, Professional Service Technicians
- Over 140,000 Installations Annually
- White Glove Service

- Satisfaction Guarantee
- Flexible Appointments, including weekends
- Coverage across the nation

Visit www.goconfigure.com for more info!

**Installation services are only available to U.S. customers.*



The store where you made your purchase does not stock parts for this item. If you have assembly questions or you are missing or have damaged parts, please call

1-800-856-4445

you can also visit www.backyarddiscovery.com
or e-mail customerservice@backyarddiscovery.com

Please have the following information ready when you make your call:

- Model Number of the product located on the front of the assembly manual
 - The item description and number from the parts list from the manual that was included in your box
-
- Read entire assembly manual, paying special attention to the important tips and safety information.
 - To ensure there are no missing pieces do a complete inventory by first separating and identifying all parts.
 - Make sure to check packing material for small parts that may have fallen out during shipment.
 - Structures are not intended for public use. The Company does not warranty any of its residential structures subjected to commercial use.
 - This manual contains helpful information concerning assembly preparation, installation procedure and required maintenance.
 - Always keep safety in mind as your structure is being built.
 - Keep these instructions for future reference.



Please read entire booklet completely before beginning the assembly process

Please retain these instructions and your receipt for future reference. Keep them in a safe place where you can refer to them as needed. In order to provide you with the most efficient service, it is required that you provide us with the part numbers when ordering parts.

For Your Records:

Please take time and fill out the information below. This information will be needed for warranty issues.

Where Purchased: _____
 Date of Purchase: _____
 Installation Date: _____
 Installed by: _____
 Tracking Number: _____

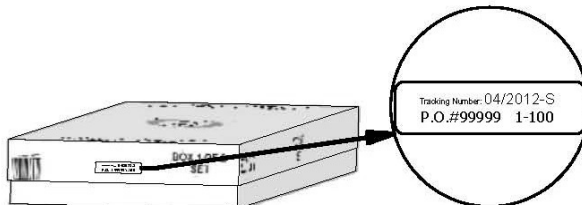
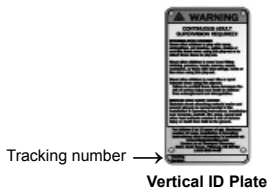

Tracking Number Reference Label

Tracking ID number on the carton and on the bottom of the vertical ID plate are included for tracking purposes associated with warranty claims.

This Limited Warranty by Backyard Discovery applies to products manufactured under the Backyard Discovery brand or its other brands including but not limited to Backyard Botanical, Adventure Playsets, and Leisure Time Products.

Backyard Discovery warrants that this product is free from defect in materials and workmanship for a period of one (1) year from the original date of purchase. This one (1) year warranty covers all parts including wood, hardware, and accessories. All wood carries a five (5) year pro-rated warranty against rot and decay. Refer to the schedule below for charges associated with replacement of parts under this Limited Warranty. In addition, Backyard Discovery will replace any parts within the first 30 days from date of purchase found to be missing from or damaged in the original packaging.

This warranty applies to the original owner and registrant and is non-transferable. Regular maintenance is required to assure maximum life and performance of this product. Failure by the owner to maintain the product according to the maintenance requirements may void this warranty. Maintenance guidelines are provided in the Owner's Manual.

This Limited Warranty does not cover:

- Installation
- Labor for any inspection
- Labor for replacement of any defective item(s)
- Incidental or consequential damages
- Cosmetic defects which do not affect performance or integrity of a part or the entire product
- Vandalism, improper use, failure due to loading or use beyond the capacities stated in the applicable Assembly Manual.
- Acts of nature including but not limited to wind, storms, hail, floods, excessive water exposure
- Improper installation including but not limited to installation on uneven, unlevel, or soft ground
- Minor twisting, warping, checking, or any other natural occurring properties of wood that do not affect performance or integrity

Backyard Discovery products have been designed for safety and quality. Any modifications made to the original product could damage the structural integrity of the unit leading to failure and possible injury. Modification voids any and all warranties and Backyard Discovery assumes no liability for any modified products or consequences resulting from failure of a modified product.

This product is warranted for RESIDENTIAL USE ONLY. Under no circumstance should a Backyard Discovery product be used in public settings. Such use may lead to product failure and potential injury. Any and all public use will void this warranty. Backyard Discovery disclaims all other representations and warranties of any kind, express or implied.

Pro Rated Part Replacement Schedule

<u>Product Age</u>	<u>Customer Pays</u>
All Parts	
0-30 days from date of purchase	\$0 and free shipping
31 days to 1 year	\$0 + S&H
Wood Rot and Decay Only	
1 year	\$0 and free shipping
2 year	20% + S&H
3 year	40% + S&H
4 year	60% + S&H
5 year	80% + S&H
Over 5 years	100% + S&H



NOTE:

Your Children's Safety Is Our #1 Concern!

Observe the following statements and warnings to reduce the likelihood of serious or fatal injury. Please review these safety rules regularly with your children.



WARNING: BURN HAZARD

- Pay special attention to plastic and metal surfaces as they may be hot enough to cause burns.
- Always check the temperature of the product before letting your children play on it.
- Remember that the product may cause burns if left in direct sunlight.
- Always be aware of the sun and weather conditions, and do not assume that the equipment is safe because the air temperature is not very high.

- Children **MUST NOT** use this playcenter until unit has been completely assembled and inspected by an adult to ensure set has been properly installed and anchored.
- Equipment is recommended for use by children 3 to 10 years of age.
- This Playcenter is designed for specific number of occupants whose combined weight should not exceed the designated weight on the elevated floor or the swing area. The total unit capacity is outlined in the Basic Setup Dimensions section of instruction manual. The maximum fall height and recommended play area is also available in the Basic Setup Dimensions section of the manual for the specific unit.
- On-site, continuous adult supervision is **REQUIRED**. **MOST SERIOUS INJURIES AND DEATHS ON PLAYGROUND EQUIPMENT HAVE OCCURRED WHILE CHILDREN WERE UNSUPERVISED!**
- **DO NOT** allow children to walk close to, in front of, behind, or between moving swings or other moving playground equipment.
- **DO NOT** let children stand on swings.
- Children should **NOT** twist the chains and ropes and should not loop them over the top support bar, this could reduce the strength of the chain or rope.
- **DO NOT** let children push empty seats. The seat could hit them and cause serious injury.
- Instruct and teach children to sit in the center of the swings with their full weight on the seats.
- **DO NOT** allow children to use the equipment in a manner other than intended.
- Instruct children **NOT** to get off equipment while it is in motion.
- Instruct children to **ALWAYS** go down slides feet first. Never slide head first.
- Instruct children to **LOOK** before they slide to make sure no one is at the bottom.
- **DO NOT** allow children to run up a slide, as this increases their chances of falling.
- **DRESS CHILDREN APPROPRIATELY.** (Examples would include wearing well-fitting shoes and the avoidance of ponchos, scarfs, and other loose-fitting clothing that is potentially hazardous while using equipment).
- **DO NOT** allow children to climb when the equipment is wet.
- Children should **NEVER** jump from a fort deck. They should always use the ladder, ramp or slide.
- Children should **NEVER** be allowed to crawl or walk across the top of monkey bars.
- **DO NOT** allow children to crawl on top of a fort roof.
- Verify that any suspended climbing ropes, chain, or cable are secured at both ends and that they cannot be looped back on themselves as to create an entanglement hazard.
- **DO NOT** let children attach items to the playground equipment that are not specifically designed for use with the equipment. Items such as, but not limited to, jump ropes, clothesline, pet leashes, cables and chain can cause a strangulation hazard.
- Children should **NEVER** wrap their legs around swing chain.
- **DO NOT** allow children to slide down the swing chain.
- Instruct children to remove their bike or other sports helmet before playing on playground equipment.
- **NEVER** add extra length to chain or rope. The chains or ropes provided are the maximum length designed for the swinging element(s).



Positioning Your Playcenter

- The playcenter is designed to be installed on a level surface by an adult with an adult helper. Place in a flat area of your yard to minimize ground preparation.
- Choose a level location for the equipment. This can reduce the likelihood of the play set tipping over and loose-fill surfacing material washing away during heavy rains.
- Place the equipment not less than 6 ft (1.8 m) from any structure or obstruction such as a fence, garage, house, overhanging branches, laundry lines, or electrical wires.
- Provide enough room so that the children can use the equipment safely. For example, for structures with multiple play activities, a slide should not exit in front of a swing.
- It is a good idea to place your playcenter in an area that is convenient for adults to watch children at play.
- Create a site free of obstacles that could cause injuries – such as low overhanging tree branches, overhead wires, tree stumps and/or roots, large rocks, bricks and concrete. Additional suggestions in the Suggested Playground Surfacing Section.
- Do not build your playset on top of surfacing material.
- Locate bare metal platforms and slides out of direct sunlight to reduce the likelihood of serious burns. A slide that faces north will receive the least direct sunlight.
- Separate active and quiet activities from each other. For example, locate sandboxes away from swings or use a guardrail or barrier to separate the sandbox from the movement of the swings.

Suggested Playground Surfacing

- Do not install home playground equipment over concrete, asphalt, packed earth, grass, carpet, or any other hard surface. A fall onto a hard surface can result in serious injury to the equipment user.
- Do not install loose fill surfacing over hard surfaces such as concrete or asphalt.
- Shredded bark mulch, wood chips, fine sand and fine gravel, are added as shock absorbing materials after assembly. If used properly these materials can absorb some of the impact of a child's fall.
- All surface material should extend a minimum of 6ft (1.8m) feet in all directions around the play area.
- Do not apply playground surfacing until after the unit is completely constructed. Playset should not be built on top of surfacing.
- Use containment, such as digging out around the perimeter and/or lining the perimeter with landscape edging.
- Installations of rubber tiles or poured-in-place surfaces (other than loose-fill materials) generally require a professional and are not "do-it-yourself" projects.
- Shall use Playground Surfacing Materials (other than loose-fill material) which comply with the safety standard ASTM F1292 Standard Specification of Impact Attenuation of Surfacing Materials within the Use Zone of Playground Equipment.

The following chart explains the fall height in feet from which a life threatening head injury would not be expected

Critical Heights in feet (m) of Tested Materials

Material	Uncompressed Depth			Compressed Depth to 9" (228mm)
	6" (152mm)	9" (228mm)	12" (304mm)	
Wood Chips	7' (2.13m)	10-12' (3.0-3.6m)	11' (3.35m)	10' (3.05m)
Double-Shredded Bark Mulch	6' (1.83m)	10-12' (3.0-3.6m)	11' (3.35m)	7' (2.13m)
Engineered Wood Fibers	6' (1.83m)	7' (2.13m)	>12' (3.66m)	6' (1.83m)
Fine Sand	5' (1.52m)	5' (1.52m)	9' (2.74m)	5' (1.52m)
Coarse Sand	5' (1.52m)	5' (1.52m)	6' (1.83m)	4' (1.22m)
Fine Gravel	5' (1.52m)	7' (2.13m)	10' (3.05m)	6' (1.83m)
Medium Gravel	5' (1.52m)	5' (1.52m)	6' (1.83m)	5' (1.52m)
Shredded Tires*	10-12' (3.0-3.6m)	N/A	N/A	N/A

*This data is from tests conducted by independent testing laboratories on a 6-inch depth of uncompressed shredded tire samples produced by four manufacturers. The tests reported critical heights, which varied from 10 feet to greater than 12 feet. It is recommended that persons seeking to install shredded tires as a protective surface request test data from the supplier showing the critical height of the material when it was tested in accordance with ASTM F1292.



APPENDIX A

The following information is from the United States Consumer Product Safety Commission's Information Sheet for playground surfacing material; also see the following website for additional information: www.cpsc.gov

X3. SECTION 4 OF THE CONSUMER PRODUCT SAFETY COMMISSION'S OUTDOOR HOME PLAYGROUND SAFETY HANDBOOK⁹

X3.1 Select Protective Surfacing—One of the most important things you can do to reduce the likelihood of serious head injuries is to install shock-absorbing protective surfacing under and around your play equipment. The protective surfacing should be applied to a depth that is suitable for the equipment height in accordance with ASTM Specification F 1292. There are different types of surfacing to choose from; whichever product you select, follow these guidelines:

X3.1.1 Loose-Fill Materials:

X3.1.1.1 Maintain a minimum depth of 9 inches of loose-fill materials such as wood mulch/chips, engineered wood fiber (EWF), or shredded/recycled rubber mulch for equipment up to 8 feet high; and 9 inches of sand or pea gravel for equipment up to 5 feet high. NOTE: An initial fill level of 12 inches will compress to about a 9-inch depth of surfacing overtime. The surfacing will also compact, displace, and settle, and should be periodically refilled to maintain at least a 9-inch depth.

X3.1.2 Use a minimum of 6 inches of protective surfacing for play equipment less than 4 feet in height. If maintained properly, this should be adequate. (At depths less than 6 inches, the protective material is too easily displaced or compacted.)

NOTE: Do not install home playground equipment over concrete, asphalt, or any other hard surface. A fall onto a hard surface can result in serious injury to the equipment user. Grass and dirt are not considered protective surfacing because wear and environmental factors can reduce their shock absorbing effectiveness. Carpeting and thin mats are generally not adequate protective surfacing. Ground level equipment such as a sandbox, activity wall, playhouse or other equipment that has no elevated play surface – does not need any protective surfacing.

X3.1.3 Use containment, such as digging out around the perimeter and/or lining the perimeter with landscape edging. Don't forget to account for water drainage.

X3.1.3.1 Check and maintain the depth of the loose-fill surfacing material. To maintain the right amount of loose-fill materials, mark the correct level on play equipment support posts. That way you can easily see when to replenish and/or redistribute the surfacing.

X3.1.3.2 Do not install loose-fill surfacing over hard surfaces such as concrete or asphalt.

X3.1.4 Poured-In-Place Surfaces or Pre-Manufactured Rubber Tiles — You may be interested in using surfacing other than loose-fill materials – like rubber tiles or poured-in-place surfaces.

X3.1.4.1 Installations of these surfaces generally require a professional and are not “do-it-yourself” projects.

X3.1.4.2 Review surface specification before purchasing this type of surfacing. Ask the installer/manufacture for a report showing that the product has been tested to the following safety standard: ASTM F 1292 Standard Specification for Impact Attenuation of Surfacing Materials within the Use Zone of Playground Equipment. This report should show the specific height for which the surface is intended to protect against serious head injury. This height should be equal to or greater than the fall height – vertical distance between a designated play surface (elevated surface for standing, sitting, or climbing) and the protective surfacing below – of your play equipment

X3.1.4.3 Check the protective surfacing frequently for wear.

X3.1.5 Placement — Proper placement and maintenance of protective surfacing is essential. Be sure to:

X3.1.5.1 Extend surfacing at least 6 feet from the equipment in all directions.

X3.1.5.2 For to-fro swings, extend protective surfacing in front of and behind the swing to a distance equal to twice the height of the top bar from which the swing is suspended.

⁹This information has been extracted from the CPSC publications “Playground Surfacing — Technical Information Guide” and “Handbook for Public Playground Safety.” Copies of these reports can be obtained by sending a postcard to the: Office of Public Affairs, U.S. Consumer Product Safety Commission, Washington, D.C., 20207 or call the toll-free hotline: 1-800-638-2772.

The American Society for Testing and Materials takes no position respecting the validity of any parent right asserted in connection with any item mentioned in this standard. Users of this standard are expressly advised that determination of the validity of any such parent rights, and the risk of infringement of such rights, are entirely their own responsibility.

The standard is subject to revision at any time by the responsible technical committee and must be reviewed every five years and if not revised, either approved or withdrawn. Your comments are invited either for revision of this standard or for additional standards and should be addressed to ASTM Headquarters. Your comments will receive careful consideration at a meeting of the responsible technical committee, which you may attend. If you feel that your comments have not received a fair hearing you should make your views known to the ASTM Committee on Standards. 100 Barr Harbor Drive, West Conshohocken, PA 19428.



IT IS IMPORTANT TO CHECK AND TIGHTEN ALL HARDWARE AT THE BEGINNING AND DURING THE SEASON AS THEY MAY LOOSEN DUE TO WOOD EXPANSION AND CONTRACTION.

At the beginning of each play season

- Tighten all hardware.
- Lubricate all metallic moving parts per manufacturer's instructions.
- Check all protective coverings on bolts, pipes, edges, and corners. Replace if they are loose, cracked, or missing.
- Check all moving parts including swing seats, ropes, cables, and chains for wear, rust, or other deterioration. Replace as needed.
- Check metal parts for rust. If found, sand and repaint using a non lead-based paint meeting the requirements of 16 CFR 1303.
- Check all wood members for deterioration and splinters. Sand down splinters and replace deteriorating wood members.
- Reinstall any plastic parts, such as swing seats or any other items that were removed for the cold season.
- Rake and check depth of loose fill protective surfacing materials to prevent compaction and to maintain appropriate depth. Replace as necessary.

Twice a month during play season

- Tighten all hardware.
- Check all protective coverings on bolts, pipes, edges, & corners. Replace if they are loose, cracked, or missing.
- Rake and check depth of loose fill protective surfacing materials to prevent compaction and to maintain appropriate depth. Replace as necessary.

Once a month during play season.

- Lubricate all metallic moving parts per manufacturer's instructions.
- Check all moving parts including swing seats, ropes, cables, and chains for wear, rust, or other deterioration. Replace as needed.

At the end of each season or when the temperature drops below 32° F

- Remove plastic swing seats and other items as specified by the manufacturer and take indoors or do not use.
- Rake and check depth of loose fill protective surfacing materials to prevent compaction and to maintain appropriate depth. Replace as necessary.

Additional Maintenance

- Check the swing beam and hardware every two weeks due to wood expansion and contraction. It is particularly important that this procedure be followed at the beginning of each season.
- Inspect wood parts monthly. The grain of the wood sometimes will lift in the dry season causing splinters to appear. Light sand may be necessary to maintain a safe playing environment. Treat your playset with stain regularly, to help prevent severe checking/ splitting and other weather damage.
- A waterborne transparent stain has been applied to your playset. This is done for color only. Once or twice a year, depending on your climate conditions, you must apply some type of protection (sealant) to the wood of your unit. Prior to the application of sealant, lightly sand any "rough" spots on your playset. Please note this is a requirement of your warranty.
- Assembling and maintaining the playset on a level location is very important. As your children play, your playset will slowly dig its way into the soil, and it is very important that it settles evenly. Make sure the playset is level and true one each year or at the beginning of each play season.

Disposal Instructions

When the Playcenter use is no longer desired, it should be disassembled and disposed of in such a way that no unreasonable hazards will exist at the time the unit is discarded.

Third Party Assembly

Customer may, in their sole discretion, elect to use a third party person or service to assemble this product. Backyard Discovery assumes no responsibility or liability for any charge incurred by the Customer for any assembly services'. Please see our warranty for more information about damaged and missing part replacement coverage. Backyard Discovery will not reimburse Customer for the price of parts purchased.

OWNERS SHALL BE RESPONSIBLE FOR MAINTAINING THE LEGIBILITY OF THE WARNING LABELS



Your Backyard Discovery structure is designed and constructed of quality materials. As with all outdoor products it will weather and wear. To maximize the enjoyment, safety and life of your structure it is important that you properly maintain it.

About Our Wood

Backyard Discovery uses 100% Cedar (C. Lanceolata) wood. Although we take great care in selecting the best quality lumber available, wood is still a product of nature and susceptible to weathering which can change the appearance of your set.

What causes weathering? Does it affect the strength of my product?

One of the main reasons for weathering is the effects of water (moisture); the moisture content of the wood at the surface is different than the interior of the wood. As the climate changes, moisture moves in or out of the wood, causing tension which can result in checking and or warping. You can expect the following due to weathering. These changes will not affect the strength of the product:

1. Checking is surface cracks in the wood along the grain. A post (4" x 4") will experience more checking than a board (1" x 4") because the surface and interior moisture content will vary more widely than in thinner wood.

2. Warping results from any distortion (twisting, cupping) from the original plane of the board and often happens from rapid wetting and drying of the wood.

3. Fading happens as a natural change in the wood color as it is exposed to sun-light and will turn grey over time.

How can I reduce the amount of weathering to wood product?

1. Your wood product is coated with a water-based stain. Sunlight will break down the coating, so we recommend applying a water repellent or stain on a yearly basis (see your local stain and paint supplier for a recommended product). You must apply some type of protection (sealant) to the wood of your product. **Please note this is a requirement of your warranty.** Most weathering is just the normal result of nature and will not affect safety. However if you are concerned that a part has experienced a severe weathering problem please call our customer service department for further assistance.

2. Inspect wood parts monthly. The grain of the wood sometimes will lift in the dry season causing splinters to appear. Light sanding may be necessary to maintain a safe environment. Treating your Product with protection (sealant) after sanding will help prevent severe checking/ splitting and other weather damage.



Protrusion Hazard

Incorrect

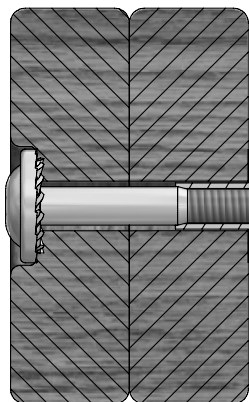

If you see exposed threads and your bolt protrudes beyond the T-Nut you may have overtightened the bolt or used incorrect hardware. If you've overtightened, remove the bolt and add washers to eliminate the protrusion.

Correct

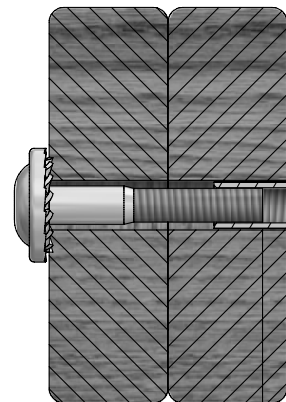

1/8"

Proper Hardware Assembly

Bolt and T-Nut Assembly

Tap T-nut into the provided hole. Insert your bolt through the lock washer and insert into the provided hole opposite from the T-Nut. Turn clockwise to thread into T-nut. Do not completely tighten until instructed.

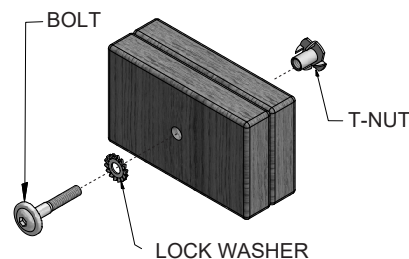

Bolt and Barrel Nut Assembly

Insert barrel nut through the lock washer and press the pair through the provided hole. Insert your bolt through the second lock washer and insert the pair into the provided hole opposite from the barrel nut. Turn clockwise to thread into the barrel nut. Do not completely tighten until instructed.

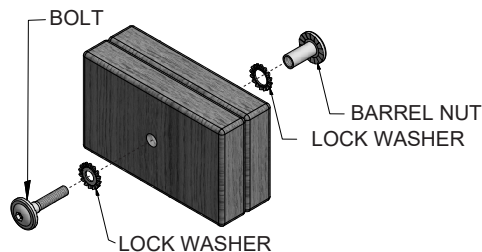

Lag Assembly

Normally there will be a pre-drilled pilot hole on assemblies that require a Lag Screw. If there is no pilot hole, line up the two boards as they are to be attached and use the factory drilled hole as a guide to drill another pilot hole into the adjoining board. This will keep the wood from splitting. Only a lock washer is required for steps with Lag Screws.

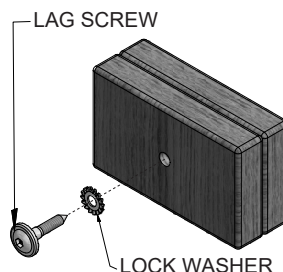



ASSEMBLY TIP:

Keep and eye out for these boxes which will contain helpful pictures and information making the assembly process as quick and painless as possible.

Sorting Wood

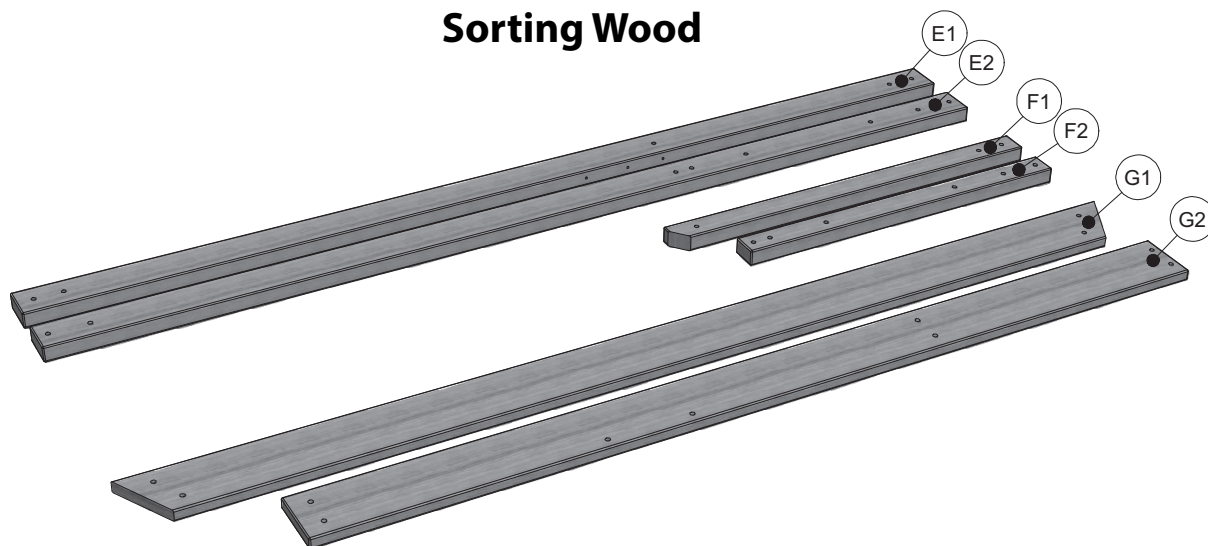

When removing the wood from the boxes we recommend arranging them by part number before you begin assembly. This will allow for faster assembly and easily identify any parts that may be missing or damaged.

Sorting Hardware

NUT BARREL
H100545



SCREW
H100695



T-NUT
H100699



WASHER FLAT
H100706



BOLT HEX
H100716

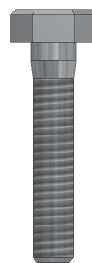

BOLT
H100718

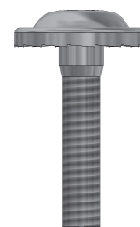

SCREW PWH
H100742



To help with assembly we recommend sorting your hardware bags with the seven digit alpha-numeric number printed on the bags or by hardware type (i.e. bolts, nuts, etc.). Organizing your hardware will make assembly easier.

Hardware Identification

Hardware bags are printed with a seven digit alpha-numeric part number. During assembly you only need to reference the last three digits of the part number as noted in each step. This will make finding the correct hardware easier.

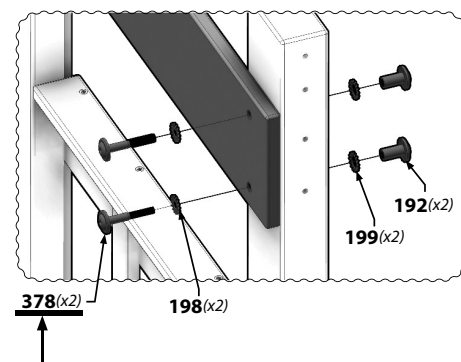
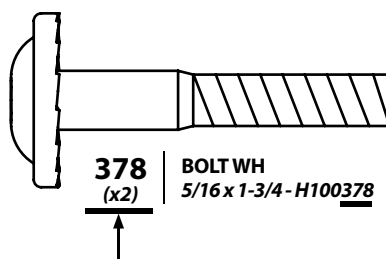

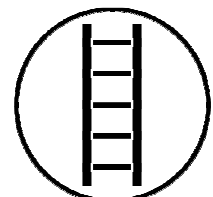
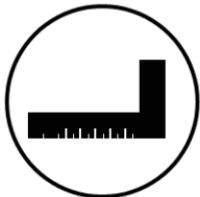
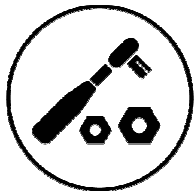
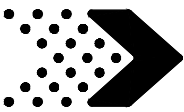

Icons and their uses you will see throughout this manual

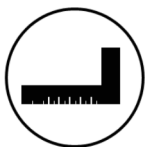

You will need to make sure that your assembly is square before tightening your bolts.



For proper assembly you will need to ensure that your structure is level before proceeding to the next step.



Some steps in the assembly process will require an extra set of hands. Make sure you have a helper available.



This icon shows the size of an open ended wrench. Using the wrench as the fraction bar.



When you see this icon you will need a socket wrench. The icons below show the size of attachments needed for assembly.



This icon warns you to not over tighten your bolts. This is to prevent structural damage and also splintering your wood.



This icon will show you what drill attachments are needed. For this example you will need a Phillips head attachment, 1/4 driver, and 1/8 drill bit.

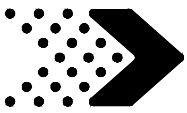

Place the set on level ground, not less than 6'-7" [2 m] from any structure or obstruction such as a fence, garage, house, overhanging branches, laundry lines, or electrical wires.

- While assembling unit, take time before and after each phase to make sure fort is level. If fort is not level, assembly will be difficult and improper assembly may result. Extra care must be taken to insure the fort is square.
- The safe play area refers to a zone extending 6'-7" [2 m] beyond the play product on all slides, including the space above the play product.

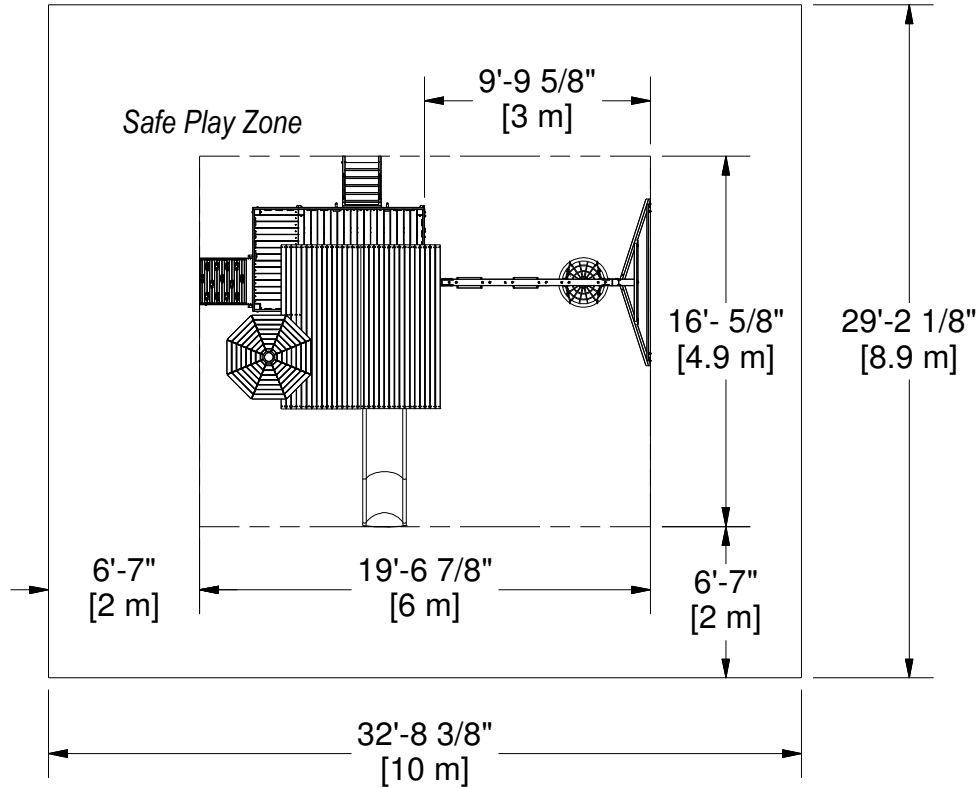

General Information:

Your set has been designed and engineered for children only and for residential use only.
 A maximum of 150 lbs. per child is recommended for play activities designed for individual use.
 A maximum of 120 lbs. per child is recommended for play activities designed for multiple child use.
 A maximum of 9 children is recommended for this swing set.

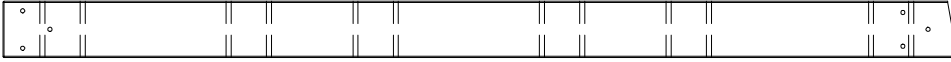
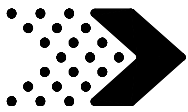

A1 | SWING BEAM - W4L12838
(x1) | 3 3/8"x5 1/4"x89 1/2" (86x134x2274)

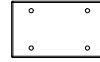

A2 | SB 9" BLOCK - W4L08962
(x1) | 3 3/8"x5 1/4"x9" (86x134x228)

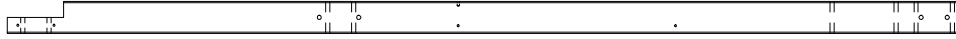

B1 | POST - W4L12809
(x1) | 3"x3"x89 5/8" (76x76x2275)



B4 | POST - W4L12811
(x1) | 3"x3"x59" (76x76x1500)

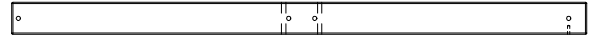

B8 | POST - W4L08475
(x1) | 3"x3"x53 7/8" (76x76x1370)

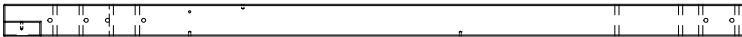

B5 | POST - W4L12812
(x1) | 3"x3"x69 3/4" (76x76x1771)

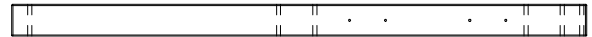

B9 | POST - W4L08476
(x1) | 3"x3"x53 7/8" (76x76x1370)



B10 | POST - W4L08484
(x1) | 3"x3"x47 1/4" (76x76x1201)



B12 | POST - W4L08487
(x1) | 3"x3"x13 5/8" (76x76x345)



B14 | POST - W4L12826
(x1) | 3"x3"x53 7/8" (76x76x1370)



B15 | POST - W4L12810
(x2) | 3"x3"x29 3/8" (76x76x746)



B16 | POST - W4L08553
(x1) | 3"x3"x53 7/8" (76x76x1370)



B17 | POST - W4L08696
(x2) | 3"x3"x33 7/8" (76x76x860)



B19 | POST - W4L12828
(x1) | 3"x3"x33 7/8" (76x76x860)



B21 | POST - W4L08746
(x1) | 3"x3"x33 7/8" (76x76x860)

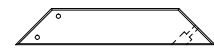

E1 | ANGLE SUPPORT - W4L08458
(x6) | 1 3/8"x3 3/8"x18 3/4" (36x86x475)

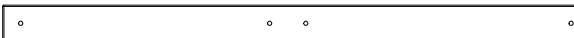

E2 | POST - W4L08522
(x2) | 3 3/8"x1 3/8"x53 7/8" (86x36x1370)

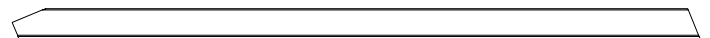

E3 | LEFT RAIL - W4L12830
(x1) | 1 3/8"x3 3/8"x64 3/4" (36x86x1645)



E4 | RIGHT RAIL - W4L12831
(x1) | 1 3/8"x3 3/8"x64 3/4" (36x86x1645)



E6 | FLOOR SUPPORT - W4L12807
(x2) | 1 3/8"x3 3/8"x54 3/8" (36x86x1382)



E7 | ANGLE BRACE - W4L08494
(x4) | 1 3/8"x3 3/8"x38 1/2" (36x86x978)



E8 | ANGLE SUPPORT BRACE - W4L12935
(x2) | 1 3/8"x3 3/8"x25 3/8" (36x86x643)



E50 | END SUPPORT - W4L11379
(x1) | 1 3/8"x3 3/8"x44 1/8" (36x86x1120)

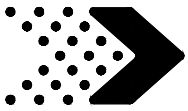

E51 | ANGLE BRACE - W4L11378
(x2) | 1 3/8"x3 3/8"x88 3/4" (36x86x2254)

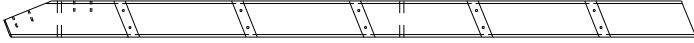

E77 | LEFT UPRIGHT - W4L12840
(x1) | 1 3/8"x3 3/8"x64 7/8" (36x86x1649)

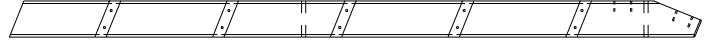

E78 | RIGHT UPRIGHT - W4L12841
(x1) | 1 3/8"x3 3/8"x64 7/8" (36x86x1649)



F1 | POST - W4L08495
(x2) | 1 3/8"x2 3/8"x54 5/8" (36x60x1389)



F2 | POST - W4L08503
(x1) | 1 3/8"x2 3/8"x47 1/4" (36x60x1200)



F3 | POST - W4L08504
(x1) | 1 3/8"x2 3/8"x47 1/4" (36x60x1200)



G1 | WALL SUPPORT - W4L12822
(x1) | 1"x5 1/4"x77 3/8" (24x134x1964)



G2 | WALL SUPPORT - W4L12824
(x1) | 1"x5 1/4"x66 5/8" (24x134x1692)



G3 | WALL SUPPORT - W4L12801
(x1) | 1"x5 1/4"x64 3/4" (24x134x1645)



G4 | CROSS BRACE - W4L12821
(x4) | 1"x5 1/4"x74 3/4" (24x134x1898)



G5 | CROSS BRACE - W4L12915
(x2) | 1"x5 1/4"x17 3/4" (24x134x450)



G6 | WALL SUPPORT - W4L12804
(x1) | 1"x5 1/4"x77 3/8" (24x134x1964)

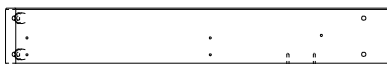

G7 | WALL SUPPORT - W4L12842
(x1) | 1"x5 1/4"x36" (24x134x915)



G9 | BASE BOARD - W4L12885
(x1) | 1"x5 1/4"x79 1/4" (24x134x2014)



G8 | WALL SUPPORT - W4L12843
(x1) | 1"x5 1/4"x32" (24x134x813)

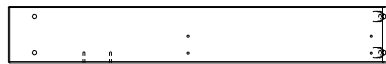

G10 | WALL SUPPORT - W4L08481
(x1) | 1"x5 1/4"x36" (24x134x915)



G11 | WALL SUPPORT - W4L08486
(x1) | 1"x5 1/4"x7 1/2" (24x134x192)



G12 | WALL SUPPORT - W4L08490
(x1) | 1"x5 1/4"x29 1/8" (24x134x741)



G13 | WALL SUPPORT - W4L08491
(x1) | 1"x5 1/4"x28 1/4" (24x134x716)



G14 | WALL SUPPORT - W4L08492
(x1) | 1"x5 1/4"x10 5/8" (24x134x269)

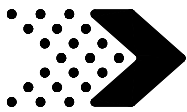

Parts Identification

Wood Components (Not to Scale)



G15 | WALL SUPPORT - W4L08545
(x1) | 1"x5 1/4"x30 1/4" (24x134x768)



G16 | WALL SUPPORT - W4L08546
(x1) | 1"x5 1/4"x14 7/8" (24x134x378)



G18 | BASE BOARD - W4L12820
(x2) | 1"x5 1/4"x56" (24x134x1422)



G17 | WALL SUPPORT - W4L12825
(x1) | 1"x5 1/4"x14 7/8" (24x134x378)



G20 | DECK BOARD - W4L12803
(x1) | 1"x5 1/4"x89 5/8" (24x134x2276)



G19 | WALL SUPPORT - W4L08560
(x1) | 1"x5 1/4"x8 5/8" (24x134x218)

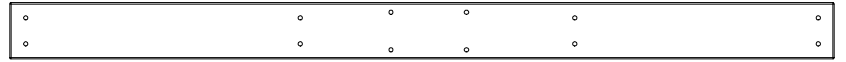

G21 | WALL SUPPORT - W4L12815
(x1) | 1"x5 1/4"x77 3/8" (24x134x1964)



G22 | DECK RAIL - W4L12816
(x1) | 1"x5 1/4"x53 1/8" (24x134x1349)



G23 | DECK BOARD - W4L08698
(x1) | 1"x5 1/4"x22" (24x134x560)



G24 | DECK BOARD - W4L12805
(x1) | 1"x5 1/4"x25 3/8" (24x134x645)



G25 | ENTRY BOARD - W4L12817
(x1) | 1"x5 1/4"x53 1/8" (24x134x1349)



G27 | BASE BOARD - W4L12819
(x1) | 1"x5 1/4"x64 3/4" (24x134x1645)



G26 | WALL SUPPORT - W4L08485
(x1) | 1"x5 1/4"x36" (24x134x915)

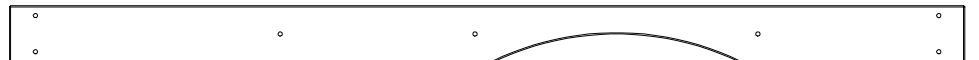

G28 | DECK BOARD - W4L12818
(x1) | 1"x5 1/4"x89 5/8" (24x134x2276)



G29 | BASE BOARD - W4L12827
(x1) | 1"x5 1/4"x89 5/8" (24x134x2275)



G30 | SLIDE ARCH BOARD - W4L12813
(x1) | 1"x5 1/4"x40 1/2" (24x134x1028)



G50 | GROUND BOARD - W4L11380
(x1) | 1"x5 1/4"x86 3/4" (24x134x2202)



H1 | WALL PICKET - W4L12829
(x3) | 1"x3 3/8"x29 3/4" (24x86x756)



H5 | FLOOR SUPPORT - W4L08479
(x1) | 1"x3 3/8"x32" (24x86x813)



H6 | FLOOR SUPPORT - W4L08482
(x1) | 1"x3 3/8"x32" (24x86x813)

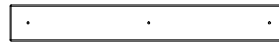

H7 | FLOOR SUPPORT - W4L08483
(x1) | 1"x3 3/8"x26" (24x86x661)



H10 | ROOF SUPPORT - W4L08513
(x1) | 1"x3 3/8"x76 3/4" (24x86x1949)



H11 | ROOF SUPPORT - W4L08518
(x1) | 1"x3 3/8"x76 3/4" (24x86x1949)

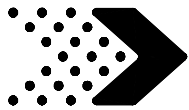

H12 | ROOF SUPPORT - W4L08519
(x1) | 1"x3 3/8"x39 1/2" (24x86x1004)



H13 | ROOF SUPPORT - W4L08520
(x1) | 1"x3 3/8"x74 3/4" (24x86x1900)

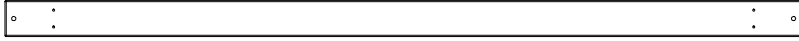

H14 | ROOF SUPPORT - W4L08521
(x1) | 1"x3 3/8"x74 3/4" (24x86x1900)

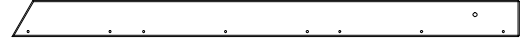

H15 | RAFTER - W4L08526
(x4) | 1"x3 3/8"x47 5/8" (24x86x1209)

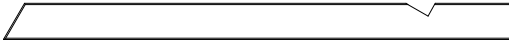

H16 | RAFTER - W4L08527
(x2) | 1"x3 3/8"x47 5/8" (24x86x1209)

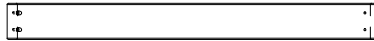

H17 | WALL SUPPORT - W4L08533
(x1) | 1"x3 3/8"x35" (24x86x889)

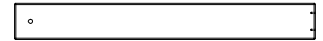

H18 | ROOF SUPPORT - W4L08541
(x1) | 1"x3 3/8"x28 1/4" (24x86x717)



H20 | FLOOR SUPPORT - W4L08562
(x9) | 1"x2 3/4"x3" (24x70x76)



H21 | BASE BOARD - W4L08563
(x1) | 1"x3 3/8"x35" (24x86x889)



H23 | FLOOR SUPPORT - W4L12800
(x1) | 1"x3 3/8"x64 3/4" (24x86x1645)



H24 | FLOOR SUPPORT - W4L08571
(x1) | 1"x3 3/8"x58 3/4" (24x86x1493)

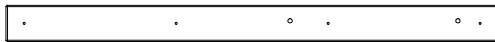

H26 | FLOOR SUPPORT - W4L08700
(x1) | 1"x3 3/8"x46 1/8" (24x86x1172)

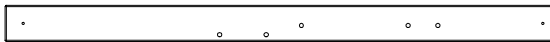

H28 | FLOOR SUPPORT - W4L12823
(x1) | 1"x3 3/8"x52 1/8" (24x86x1324)

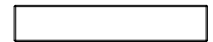

H76 | LADDER RUNG - W4L06609
(x5) | 1"x3 3/8"x18 1/8" (24x86x460)



H110 | ATTACHMENT BOARD - W4L12839
(x1) | 1"x3 3/8"x20 1/8" (24x86x512)



J1 | WALL SUPPORT - W4L08496
(x2) | 1"x2 3/8"x27 1/8" (24x60x688)

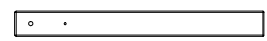

J2 | FLOOR SUPPORT - W4L12844
(x1) | 1"x2 3/8"x23 3/8" (24x60x594)



J3 | FLOOR SUPPORT - W4L12845
(x1) | 1"x2 3/8"x24 3/8" (24x60x619)

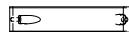

J4 | WALL SUPPORT - W4L08550
(x1) | 1"x2 3/8"x11 5/8" (24x60x295)

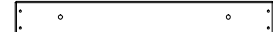

J31 | ATTACHMENT BOARD - W4L12836
(x1) | 1"x3 3/8"x24 1/4" (24x86x615)



K4 | FLOOR BOARD - W4L12808
(x1) | 5/8"x5"x64 3/4" (16x128x1644)



K6 | WALL PICKET - W4L08561
(x1) | 5/8"x5 1/4"x43 1/4" (16x132x1099)



L1 | FLOOR BOARD - W4L12916
(x2) | 5/8"x4 3/8"x34" (16x112x865)

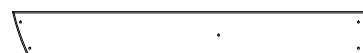

L4 | FLOOR BOARD - W4L12917
(x2) | 5/8"x4 3/8"x33 1/2" (16x112x852)



L5 | FLOOR BOARD - W4L12918
(x2) | 5/8"x4 3/8"x31 7/8" (16x112x811)



L6 | FLOOR BOARD - W4L12919
(x2) | 5/8"x4 3/8"x27" (16x112x687)

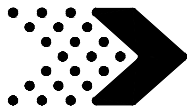

L8 | WALL PICKET - W4L08046
(x4) | 5/8"x4 3/8"x9 5/8" (16x112x244)



M1 | FLOOR BOARD - W4L08489
(x1) | 5/8"x3 3/8"x34 1/4" (16x86x869)



M7 | FLOOR BOARD - W4L08038
(x2) | 5/8"x2 1/2"x19 3/8" (16x62x493)



M16 | WALL BOARD - W4L08530
(x2) | 5/8"x3 3/8"x34 1/8" (16x86x867)



M17 | WALL BOARD - W4L08531
(x2) | 5/8"x3 3/8"x22 3/8" (16x86x567)



M18 | WALL BOARD - W4L08532
(x2) | 5/8"x3"x10 1/2" (16x77x268)



M20 | WALL BOARD - W4L08536
(x1) | 5/8"x3 3/8"x20 1/2" (16x86x521)



M23 | WALL PICKET - W4L08544
(x16) | 5/8"x3 3/8"x29 7/8" (16x86x759)

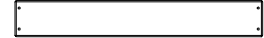

M26 | ROCK WALL BOARD - W4L12832
(x9) | 5/8"x3 3/8"x23 1/4" (16x86x590)



M28 | ROCK WALL BOARD - W4L12833
(x4) | 5/8"x3 3/8"x23 1/4" (16x86x590)

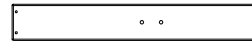

M29 | ROCK WALL BOARD - W4L12834
(x5) | 5/8"x3 3/8"x23 1/4" (16x86x590)



M30 | ROCK WALL END BOARD - W4L12835
(x1) | 5/8"x3 3/8"x24 1/4" (16x86x615)

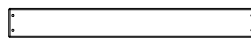

M31 | ROCK WALL BOARD - W4L12837
(x1) | 5/8"x2 3/4"x23 1/4" (16x69x590)



M38 | TURRET FILLER BOARD - W4L11445
(x2) | 5/8"x3 3/8"x5 3/4" (16x86x146)



M39 | FLOOR BOARD - W4L11558
(x1) | 5/8"x3"x18 7/8" (16x76x480)



M73 | REAR SUPPORT - W4L11417
(x1) | 5/8"x3 3/8"x20 1/8" (16x86x512)



N2 | WINDOW BOTTOM - W4L08538
(x1) | 5/8"x2 3/8"x25 1/4" (16x60x640)

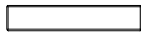

N3 | WINDOW SIDE - W4L08539
(x2) | 5/8"x2 3/8"x12 5/8" (16x60x321)

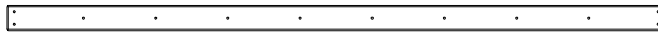

N4 | ROCK WALL CLEAT - W4L12847
(x1) | 5/8"x2 3/8"x61 3/4" (16x60x1568)



N6 | RAFTER CLEAT - W4L11446
(x1) | 5/8"x2 3/8"x3 1/8" (16x60x80)



O1 | WALL PICKET - W4L08506
(x60) | 5/8"x1 3/8"x32 7/8" (16x34x835)



O2 | WALL PICKET - W4L08047
(x2) | 5/8"x3"x9 5/8" (16x75x244)

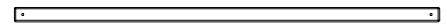

O3 | WALL PICKET - W4L08512
(x1) | 5/8"x1 3/8"x39 7/8" (16x34x1013)



SP50 | SWING BEAM SUPPORT - W4L11377
(x1) | 3 3/8"x3 3/8"x49 3/8" (86x86x1254)



T1 | FLOOR SUPPORT - W4L08466
(x2) | 1"x1 3/8"x48 3/8" (24x34x1230)



T2 | WALL BOARD - W4L12846
(x2) | 1"x1 3/8"x5 7/8" (24x34x150)



Y1 | FLOOR BOARD - W4L12806
(x1) | 5/8"x4"x64 3/4" (16x102x1644)



Y2 | FLOOR BOARD - W4L12814
(x1) | 5/8"x4"x64 3/4" (16x102x1644)

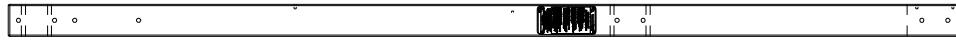
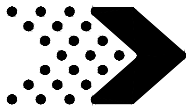

B2 | POST - W2A02902
(x1) | 3"x3"x89 5/8" (76x76x2275)

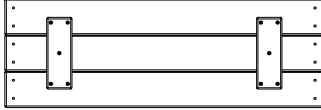

WP1 | RIGHT WALL PANEL - W2A02903
(x2) | 1 1/4"x10 3/16"x29 7/8" (32x258x759)

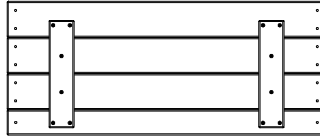

WP2 | RIGHT WALL PANEL - W2A02904
(x2) | 1 1/4"x10 3/16"x29 7/8" (32x258x759)

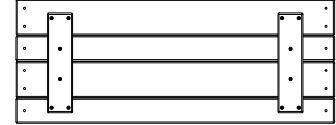

WP4 | WALL PANEL - W2A02906
(x2) | 1 1/4"x11 5/8"x29 7/8" (32x295x759)



WP3 | REAR FORT WALL - W2A02905
(x2) | 1 1/4"x8 1/8"x53 15/16" (32x212x1370)



WP5 | WALL PANEL - W2A02907
(x1) | 1 1/4"x9 13/16"x39 7/8" (32x250x1013)

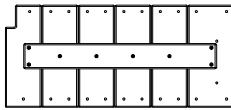

WP7 | WALL PANEL - W2A02909
(x1) | 1/16"x1/16"x1/16" (32x547x243)

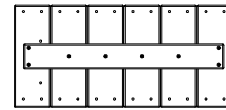

WP6 | WALL PANEL - W2A02908
(x1) | 1/16"x1/16"x1/16" (32x243x521)

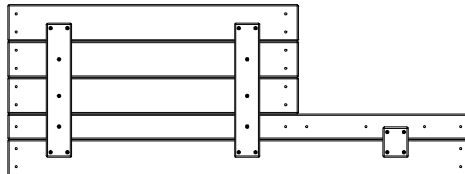

WP8 | LEFT WINDOW WALL PANEL - W2A02910
(x1) | 1 1/4"x16"x43 1/4" (32x407x1099)

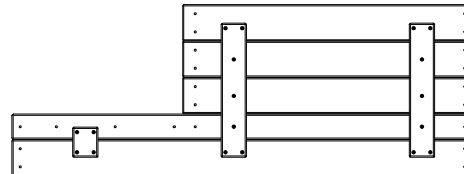

WP9 | RIGHT WINDOW WALL PANEL - W2A02911
(x1) | 1 1/4"x15 7/8"x43 1/4" (32x404x1099)

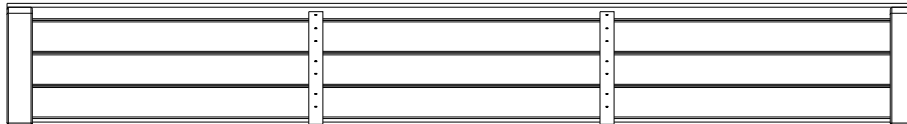

RP01 | ROOF PANEL - W2A02182
(x2) | 1/16"x1/16"x1/16" (40x287x2165)

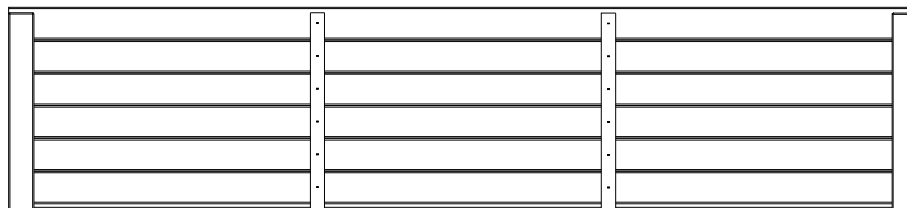

RP02 | ROOF PANEL - W2A020184
(x2) | 1 9/16"x19 1/4"x85 3/16" (40x488x2165)

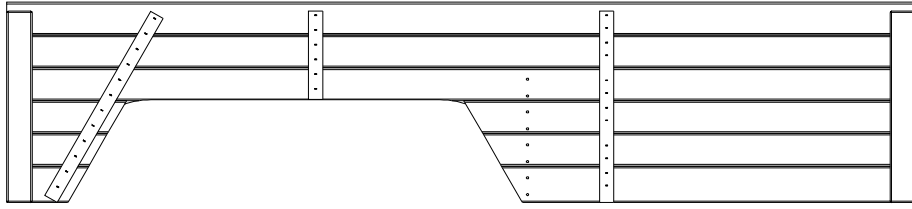
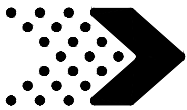

RP03 | ROOF PANEL - W2A02185
(x1) | 1 9/16"x18 3/4"x85 3/16" (40x476x2165)

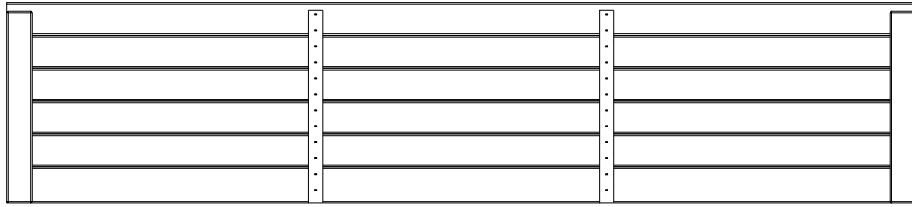

RP04 | ROOF PANEL - W2A02186
(x1) | 1 9/16"x18 3/4"x85 1/4" (40x476x2165)

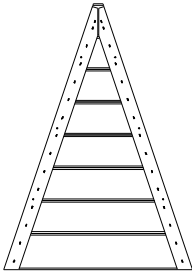

RP07 | ROOF PANEL - W2A02189
(x8) | 13/16"x24 7/8"x17 11/16" (21x632x450)

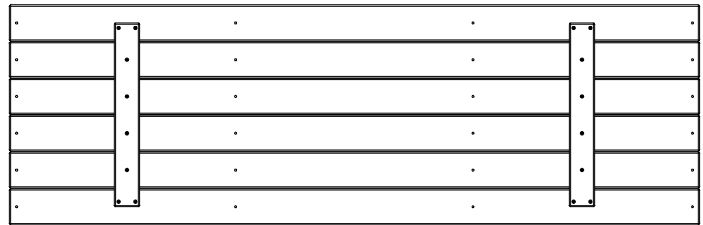

FP1 | FLOOR PANEL - W2A02900
(x2) | 1 1/4"x20 9/16"x65 11/16" (32x523x1644)

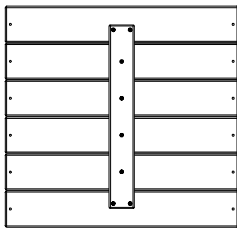

FP3 | FLOOR PANEL - W2A02227
(x2) | 1 1/4"x22 1/16"x20 11/16" (32x555x525)

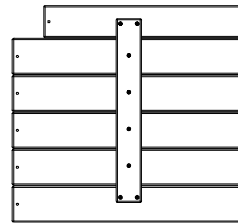

FP4 | FLOOR PANEL - W2A02228
(x1) | 1 1/4"x20 1/4"x22" (32x515x555)

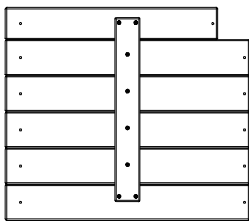

FP5 | FLOOR PANEL - W2A02229
(x1) | 1 1/4"x19 15/16"x22 15/16" (32x506x582)

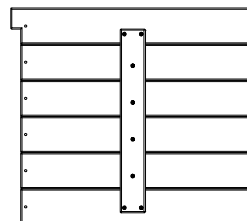

FP6 | FLOOR PANEL - W2A02230
(x1) | 1 1/4"x20 5/16"x22 15/16" (32x516x582)

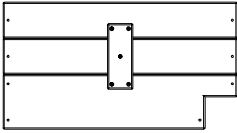
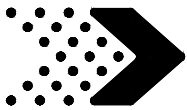

FP7 | FLOOR PANEL - W2A02248
(x1) | 1 1/4"x12 1/16"x22 1/16" (32x302x558)

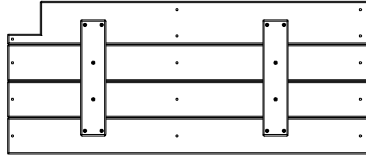

FP8 | FLOOR PANEL - W2A02912
(x1) | 1 1/4"x14 5/16"x34 3/16" (32x363x869)

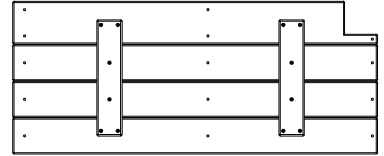

FP9 | FLOOR PANEL - W2A02913
(x1) | 1 1/4"x14 5/16"x34 3/16" (32x363x869)

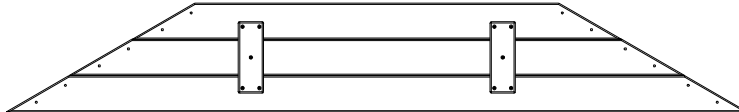

GP1 | GABLE PANEL - W2A02914
(x2) | 1 1/4"x69 1/2"x10 3/16" (32x1766x259)

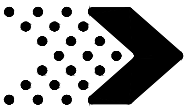

H100396 | BOLT WH BLK
(x7) | 5/16x1/2

H100363 | BOLT WH BLK
(x1) | 5/16x6



H100468 | BOLT WH BLK
(x23) | 5/16x1

H100480 | BOLT WH BLK
(x3) | 5/16x4 3/4



H100534 | BOLT WH BLK
(x1) | 5/16x4 1/2



H100378 | BOLT WH BLK
(x18) | 5/16x1 3/4

H100415 | BOLT WH BLK
(x103) | 5/16x3 3/4



H100457 | BOLT WH BLK
(x4) | 5/16x2

H100503 | BOLT WH BLK
(x4) | 5/16x3-1/2



H100205 | BOLT WH BLK
(x26) | 5/16x2-1/4

H100484 | BOLT WH BLK
(x9) | 5/16x3 1/4



H100195 | BOLT WH BLK
(x7) | 5/16x2-3/4

H100416 | BOLT WH BLK
(x22) | 5/16x3

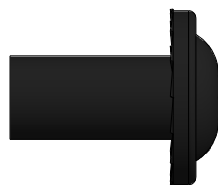

H100192 | NUT BARREL WH BLK
(x26) | 5/16x7/8



H100193 | NUT BARREL WH BLK
(x2) | 5/16x1-1/2

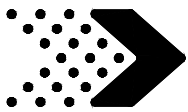

Parts Identification

Hardware Components



H100171 | BOLT WH BLK
(x12) | 1/4x1



H100397 | BOLT WH BLK
(x1) | 1/4x1 1/4



H100406 | BOLT WH BLK
(x2) | 1/4x1 1/2



H100488 | BOLT WH BLK
(x4) | 1/4x2



H100567 | BOLT WH BLK
(x22) | 1/4x2 1/4



H100800 | BOLT WH BLK
(x2) | 1/4x3



H100481 | BOLT HEX BLK
(x4) | 5/16x1 1/4



H100404 | NUT BARREL WH BLK
(x10) | 1/4x5/8

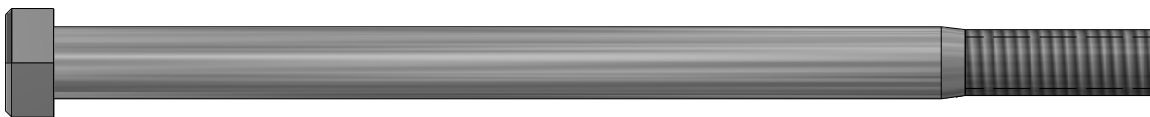

H100665 | BOLT HEX SD
(x13) | 3/8x5 3/4



H100489 | BOLT PTH BLK
(x36) | 1/4x3/4

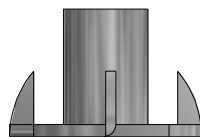

H100700 | T-NUT SD
(x13) | 3/8

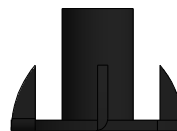

H100379 | T-NUT BLK
(x195) | 5/16



H100398 | T-NUT BLK
(x59) | 1/4



H100482 | LAG SCREW WH BLK
(x2) | 5/16x3 1/2



H100197 | LAG SCREW WH BLK
(x25) | 5/16x2 1/2



H100458 | LAG SCREW WH BLK
(x9) | 5/16x2



H100471 | LAG SCREW WH BLK
(x3) | 5/16x1 1/2



H100487 | LAG SCREW WH BLK
(x9) | 1/4x2



H100460 | LAG SCREW WH BLK
(x4) | 1/4x1

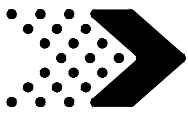

Parts Identification

Hardware Components



H100203 | SCREW PFH BLK
(x4) | 8x1/2



H100380 | SCREW PFH BLK
(x35) | 8x1 1/8



H100387 | SCREW PFH BLK
(x336) | 8x1-1/4



H100200 | SCREW PFH BLK
(x301) | 8x1 1/2



H100382 | SCREW PFH BLK
(x14) | 8x1 3/4



H100391 | SCREW PFH BLK
(x110) | 8x2



H100362 | SCREW PFH BLK
(x9) | 8x3

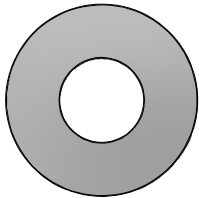

H100703 | WASHER FLAT SD
(x13) | 11x25

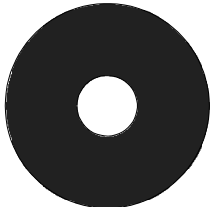

H100478 | WASHER FLAT BLK
(x4) | 8x27



H100630 | WASHER FLAT BLK
(x11) | 8x19



H100653 | NUT LOCK BLK
(x11) | 1/4

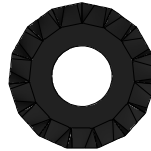

H100198 | WASHER LOCK EXT BLK
(x206) | 8x19



H100474 | WASHER FLAT BLK
(x9) | 9x18



H100477 | WASHER SPLIT BLK
(x4) | 5/16

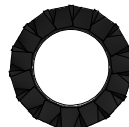

H100400 | WASHER LOCK EXT BLK
(x10) | 8x15



H100746 | SCREW PWH SD
(x150) | 10x1 1/4



H100736 | SCREW PWH SD
(x1) | 8x1 5/8



H100408 | SCREW PWH BLK
(x2) | 8x1/2



H100392 | SCREW PWH BLK
(x76) | 8x3/4

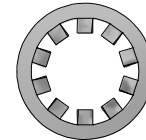

H100708 | WASHER LOCK INT SD
(x13) | 10x18

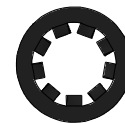

H100473 | WASHER LOCK INT BLK
(x28) | 8x15



H100199 | WASHER LOCK EXT BLK
(x15) | 12x19

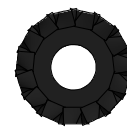

H100405 | WASHER LOCK EXT BLK
(x14) | 6x15

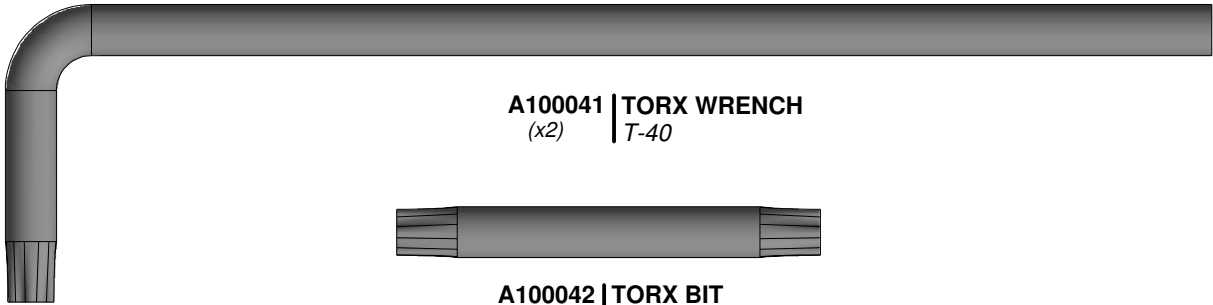
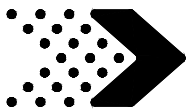

A100041 | TORX WRENCH
(x2) | T-40



A100042 | TORX BIT
(x2) | T-40

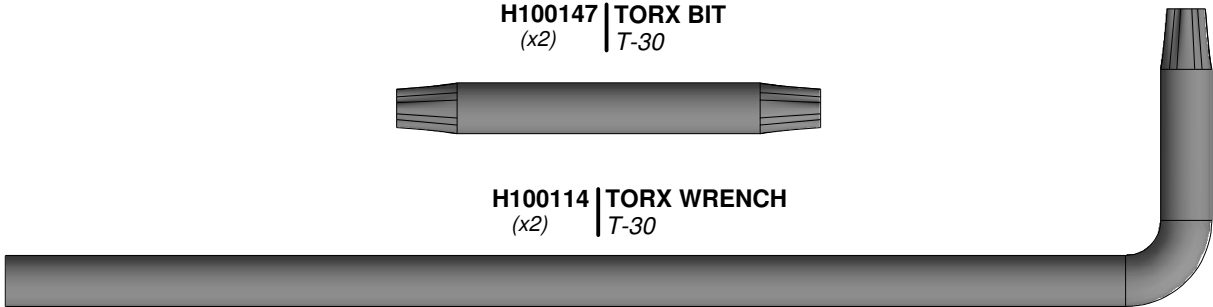

H100147 | TORX BIT
(x2) | T-30



H100114 | TORX WRENCH
(x2) | T-30



H100764 | SCREW SETTER
(x1)

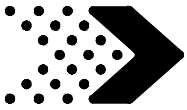

A100118 | HAND GRIP METAL GREEN 381 c/c
(x4)



A100164 | BYD ID TAG (LARGE) AGES 3-10
(x1)



A100134 | HAND GRIP GREEN 816 C/C
(x2)



A100178 | METAL GROUND STAKE BROWN
(x8)

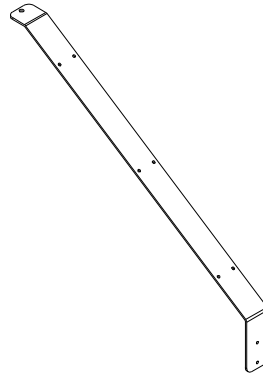

A100314 | "A" REVISION TAG
(x1)

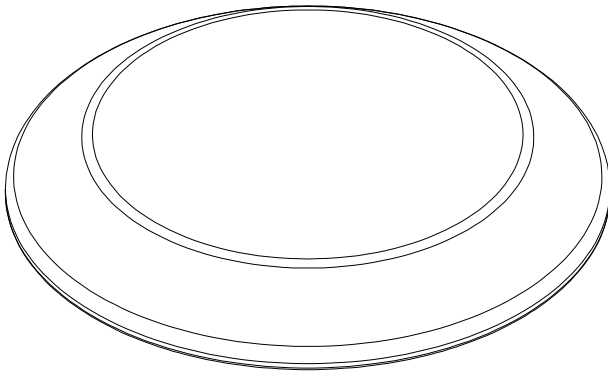
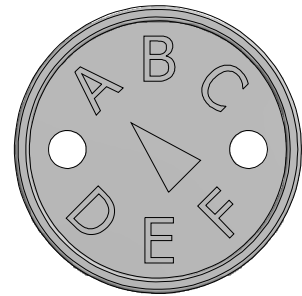

A6P00239 | ROUND ROOF PLASTIC CAP
(x1)

A4M00842 | METAL ROOF FULL RIB
(x8)

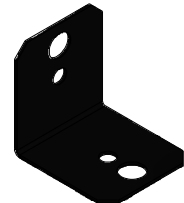

A4M00555 | 90° L-BRACKET - BLK
(x4)

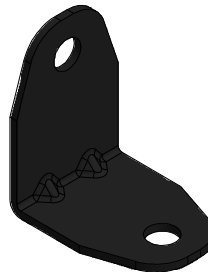

A4M00615 | L BRACKET BLK
(x3)

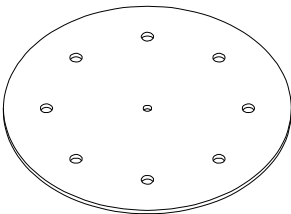

A4M00844 | ROUND ROOF RIB CONNECTOR PLATE
(x1)

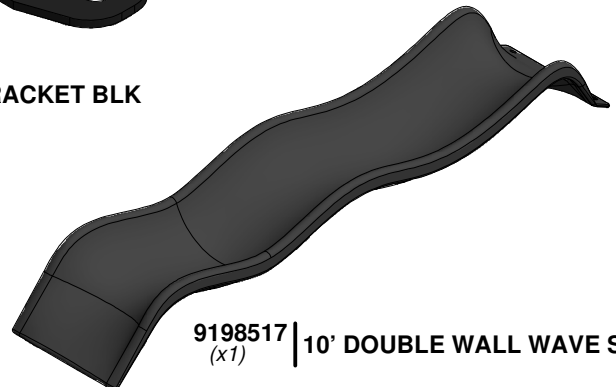

9198517 | 10' DOUBLE WALL WAVE SLIDE
(x1)

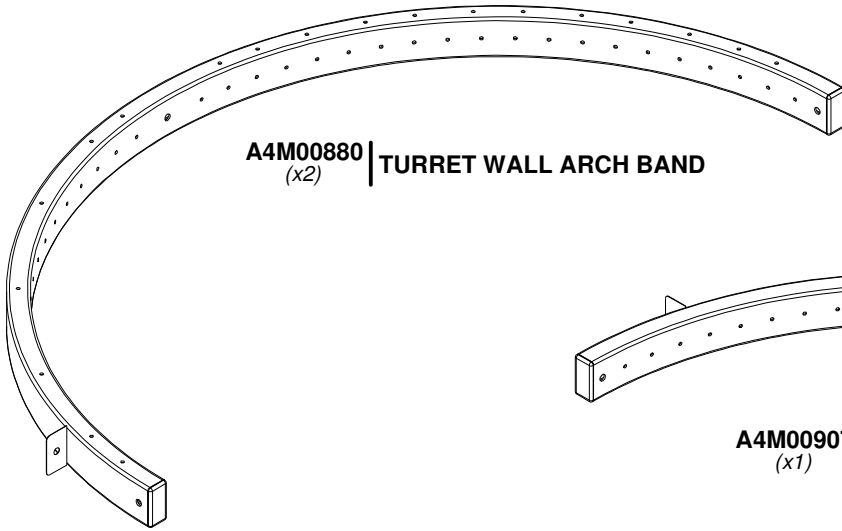
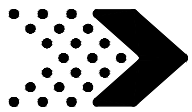

A4M00880 | TURRET WALL ARCH BAND
(x2)

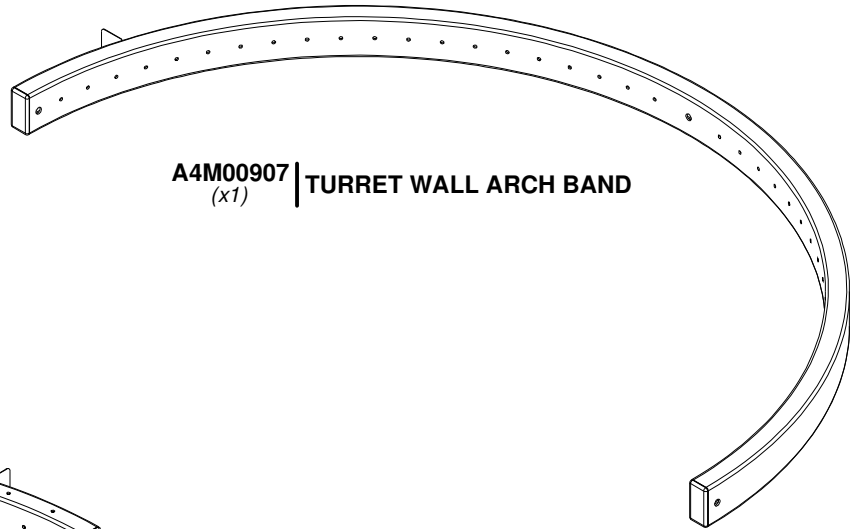

A4M00907 | TURRET WALL ARCH BAND
(x1)

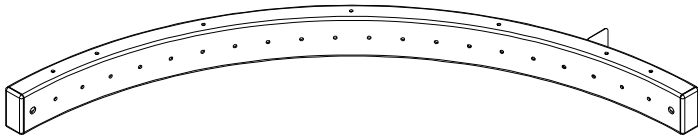

A4M00881 | QUARTER ROUND TURRET FLOOR SUPPORT
(x2)

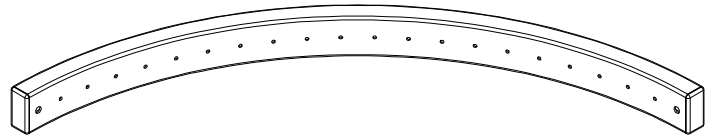

A4M00883 | QUARTER ROUND TURRET FLOOR SUPPORT
(x1)

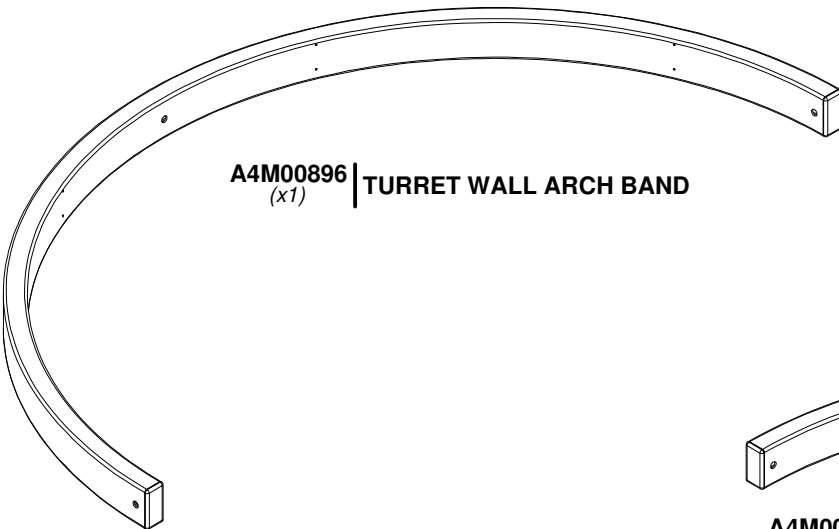

A4M00896 | TURRET WALL ARCH BAND
(x1)



A4M00897 | QUARTER ROUND TURRET FLOOR SUPPORT
(x2)

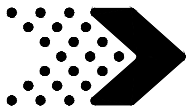

Parts Identification

Accessories (Not to Scale)

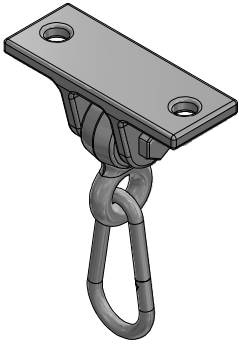

A4M00926 | SINGLE DUCTILE HANGER SD
(x6)

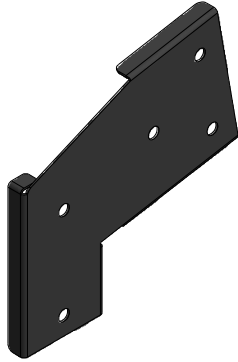

A100326 | SWING BEAM EXTENSION BRACKET-RIGHT
(x1)

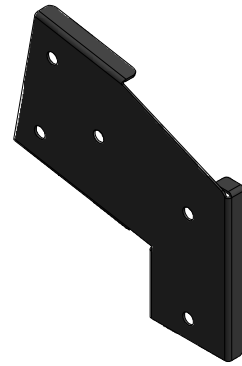

A100325 | SWING BEAM EXTENSION BRACKET-LEFT
(x1)

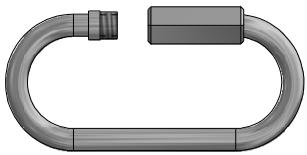

A4M00927 | QUICK LINK SD
(x4)



A6P00253 | 26" WEB SWING SEAT
(x1)

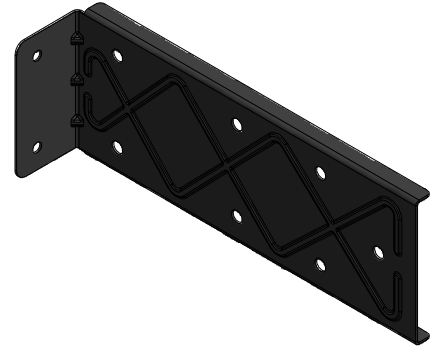

A4M00993 | EXTENDED SWING BEAM BRACKET
(x2)

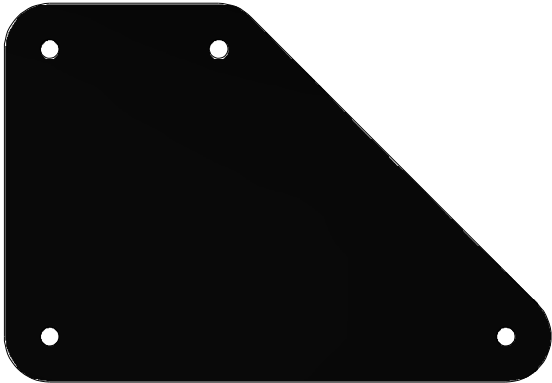

A4M00827 | TRIANGLE BRACE - BLK
(x4)

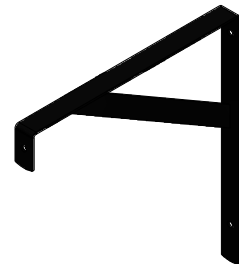

A4M01012 | METAL ANGLE BRACE
(x2)



A6P00362 | 26" HD BELT SWING
(x2)



A6P00036 | GREEN HC ROCK #1
(x6)



A6P00037 | GREEN HC ROCK #2
(x7)



A4M01005 | CHAIN GREEN 7mm x 1452mm (57in)
(x4)

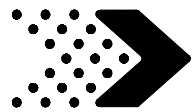

Phase 1

STEP 1

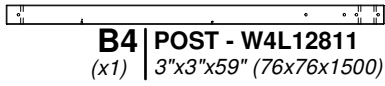

B4 | POST - W4L12811
(x1) | 3"x3"x59" (76x76x1500)

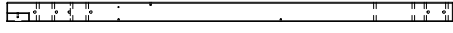

B5 | POST - W4L12812
(x1) | 3"x3"x69 3/4" (76x76x1771)

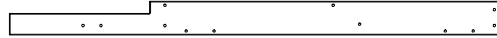

G1 | WALL SUPPORT - W4L12822
(x1) | 1"x5 1/4"x77 3/8" (24x134x1964)

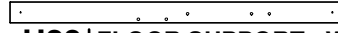

H28 | FLOOR SUPPORT - W4L12823
(x1) | 1"x3 3/8"x52 1/8" (24x86x1324)

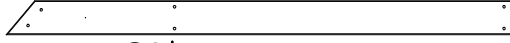

G9 | BASE BOARD - W4L12885
(x1) | 1"x5 1/4"x79 1/4" (24x134x2014)



A4M00827 | TRIANGLE BRACE - BLK
(x2)



H100480 | BOLT WH BLK
(x1) | 5/16x4 3/4



H100415 | BOLT WH BLK
(x6) | 5/16x3 3/4



H100416 | BOLT WH BLK
(x4) | 5/16x3



H100382 | SCREW PFH BLK
(x2) | 8x1 3/4



H100379 | T-NUT BLK
(x11) | 5/16



H100198 | WASHER LOCK EXT BLK
(x7) | 8x19



NOTE:

ASSEMBLE THE SUB ASSEMBLY FIRST.



TIP:

1. FOR EASE OF ASSEMBLY WE RECOMMEND USING SAW HORSES TO ASSEMBLE FORT.
2. WE RECOMMEND INSTALLING T-NUTS INTO BOARDS BEFORE ASSEMBLY.

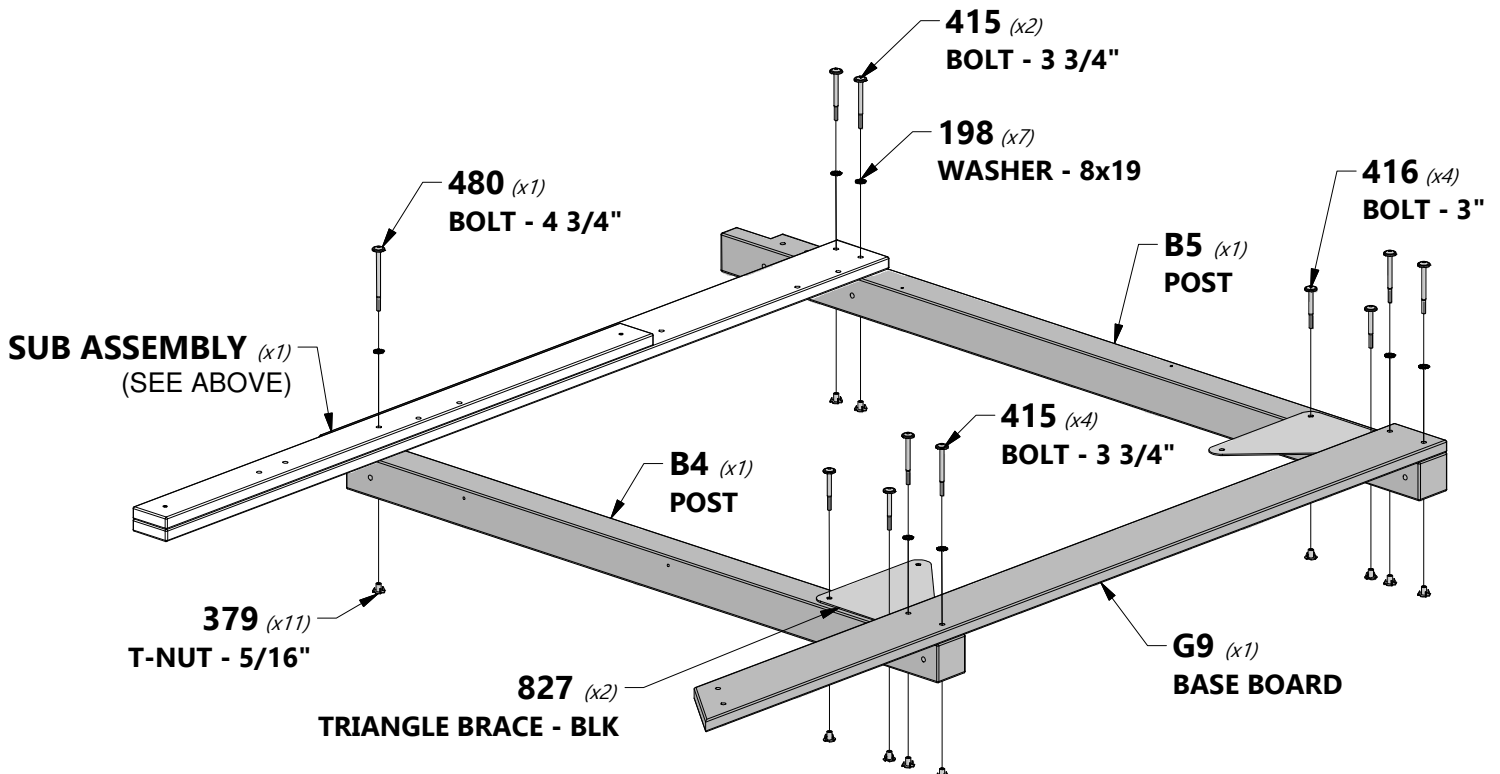
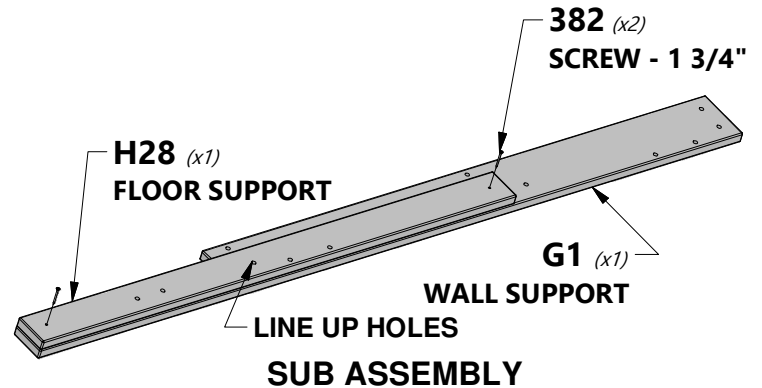

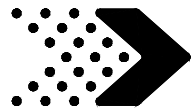

Phase 1

STEP 2

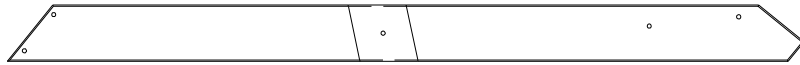

G4 | CROSS BRACE - W4L12821
(x2) | 1"x5 1/4"x74 3/4" (24x134x1898)



H100468 | BOLT WH BLK
(x5) | 5/16x1



H100378 | BOLT WH BLK
(x2) | 5/16x1 3/4



H100195 | BOLT WH BLK
(x2) | 5/16x2-3/4



H100198 | WASHER LOCK EXT BLK
(x5) | 8x19



H100379 | T-NUT BLK
(x9) | 5/16



TIP:

1. FOR EASE OF ASSEMBLY WE RECOMMEND USING SAW HORSES TO ASSEMBLE FORT.
2. WE RECOMMEND INSTALLING T-NUTS INTO BOARDS BEFORE ASSEMBLY.

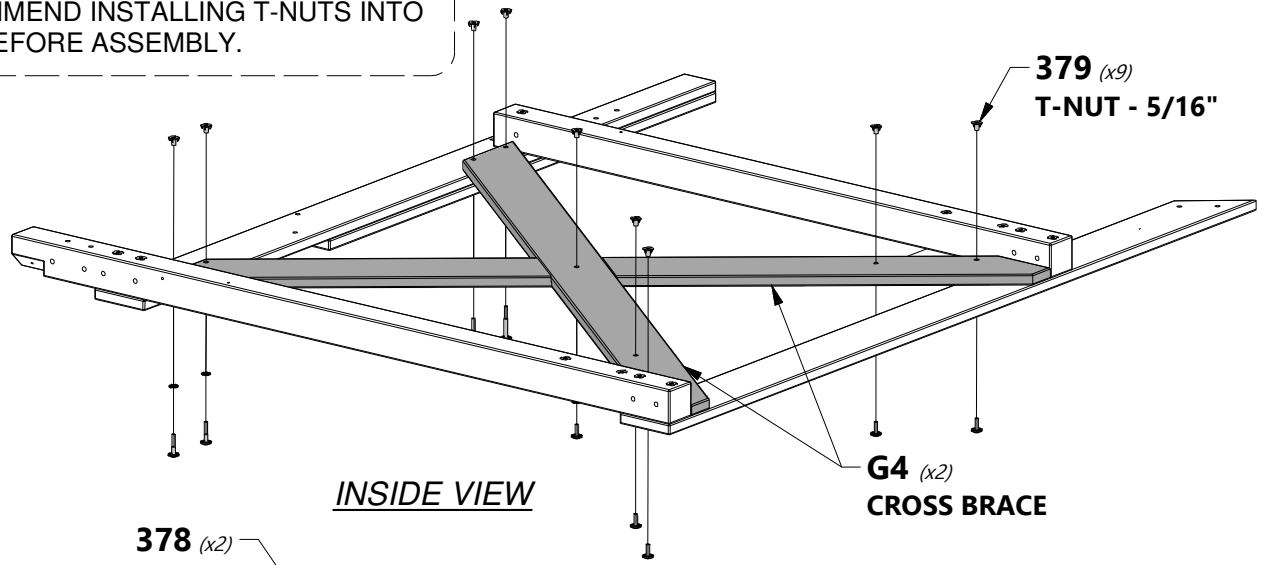

INSIDE VIEW

379 (x9)
T-NUT - 5/16"

G4 (x2)
CROSS BRACE

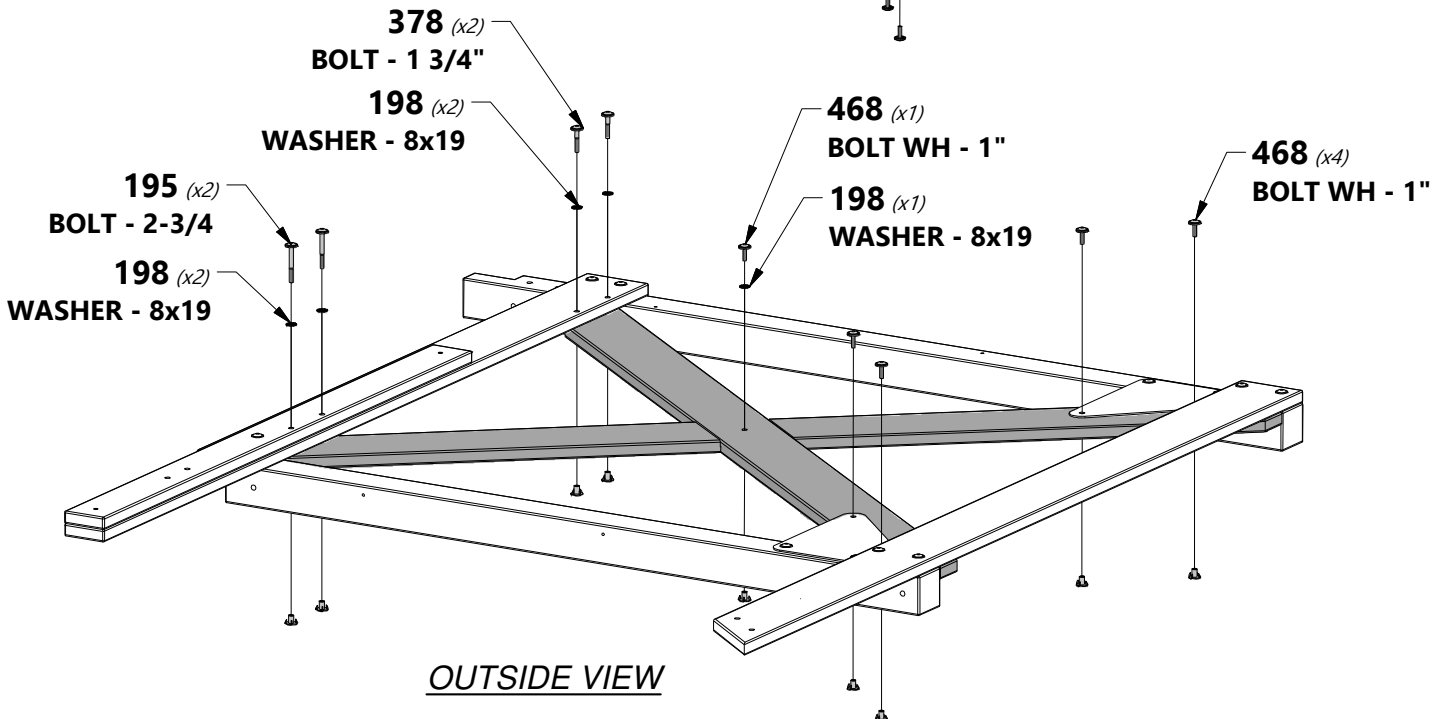

OUTSIDE VIEW

378 (x2)
BOLT - 1 3/4"

198 (x2)
WASHER - 8x19

468 (x1)
BOLT WH - 1"

198 (x1)
WASHER - 8x19

468 (x4)
BOLT WH - 1"

195 (x2)
BOLT - 2-3/4

198 (x2)
WASHER - 8x19

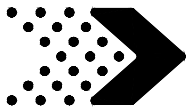

Phase 1

STEP 3

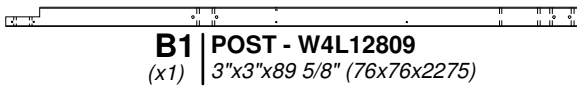

B1 | POST - W4L12809
(x1) | 3"x3"x89 5/8" (76x76x2275)

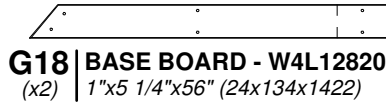

G18 | BASE BOARD - W4L12820
(x2) | 1"x5 1/4"x56" (24x134x1422)

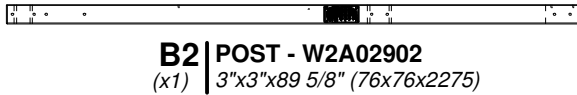

B2 | POST - W2A02902
(x1) | 3"x3"x89 5/8" (76x76x2275)

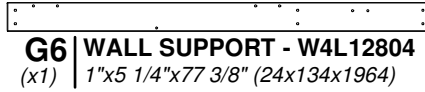

G6 | WALL SUPPORT - W4L12804
(x1) | 1"x5 1/4"x77 3/8" (24x134x1964)



A4M00827 | TRIANGLE BRACE - BLK
(x2)



H100468 | BOLT WH BLK
(x2) | 5/16x1



H100198 | WASHER LOCK EXT BLK
(x10) | 8x19



H100416 | BOLT WH BLK
(x4) | 5/16x3



H100379 | T-NUT BLK
(x14) | 5/16



H100415 | BOLT WH BLK
(x8) | 5/16x3 3/4



NOTE:
ASSEMBLE THE SUB ASSEMBLY FIRST.



TIP:
1. FOR EASE OF ASSEMBLY WE RECOMMEND USING SAW HORSES TO ASSEMBLE FORT.
2. WE RECOMMEND INSTALLING T-NUTS INTO BOARDS BEFORE ASSEMBLY.

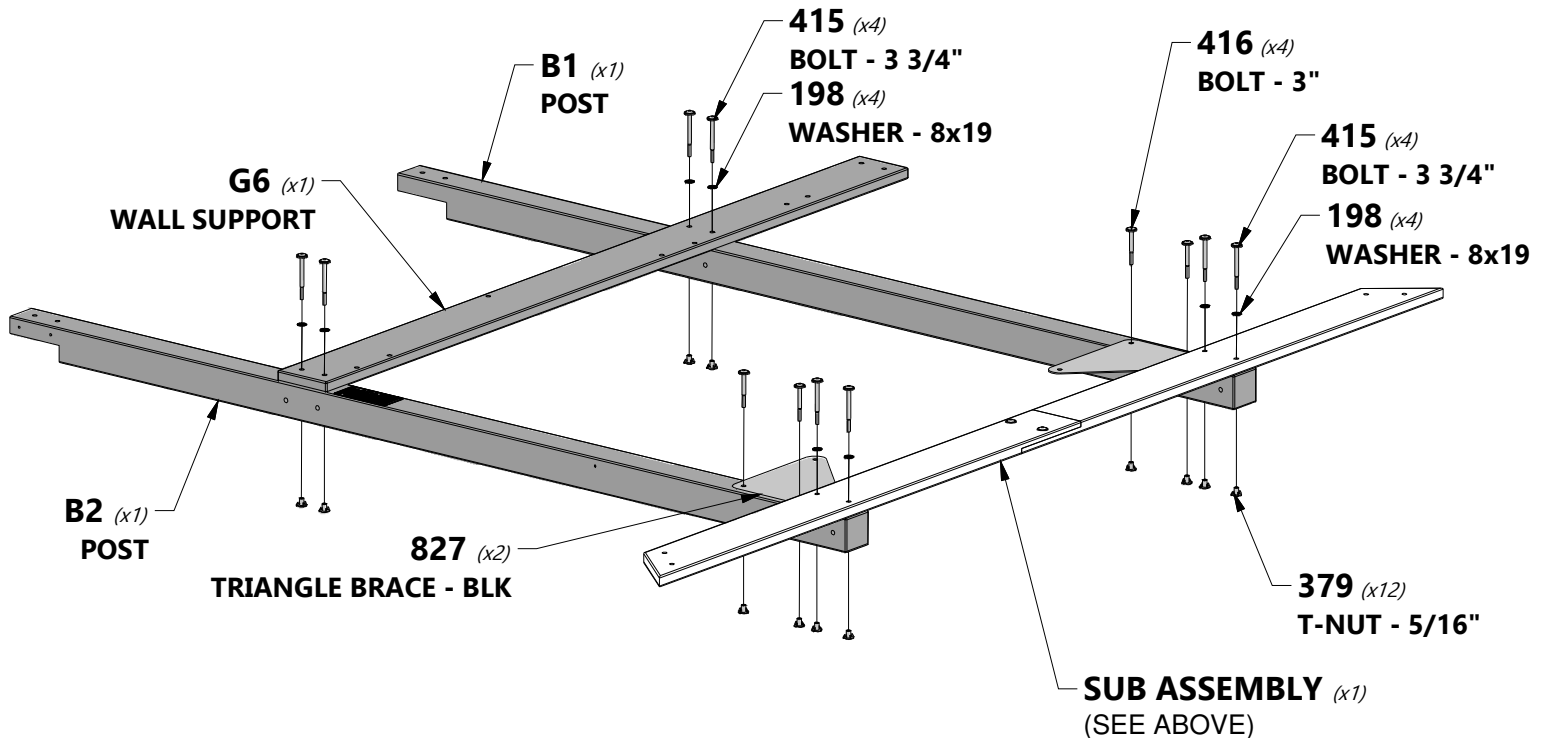
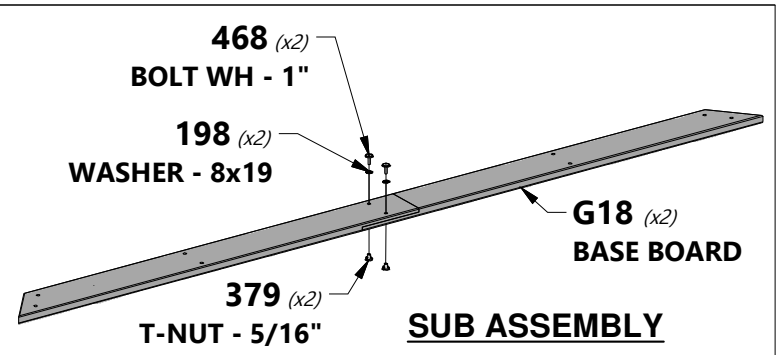

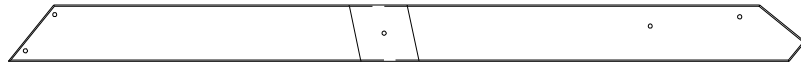
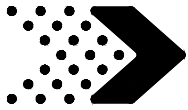

G4 | CROSS BRACE - W4L12821
(x2) | 1"x5 1/4"x74 3/4" (24x134x1898)



H100468 | BOLT WH BLK
(x5) | 5/16x1



H100378 | BOLT WH BLK
(x4) | 5/16x1 3/4



H100198 | WASHER LOCK EXT BLK
(x5) | 8x19



H100379 | T-NUT BLK
(x9) | 5/16



TIP:

1. FOR EASE OF ASSEMBLY WE RECOMMEND USING SAW HORSES TO ASSEMBLE FORT.
2. WE RECOMMEND INSTALLING T-NUTS INTO BOARDS BEFORE ASSEMBLY.

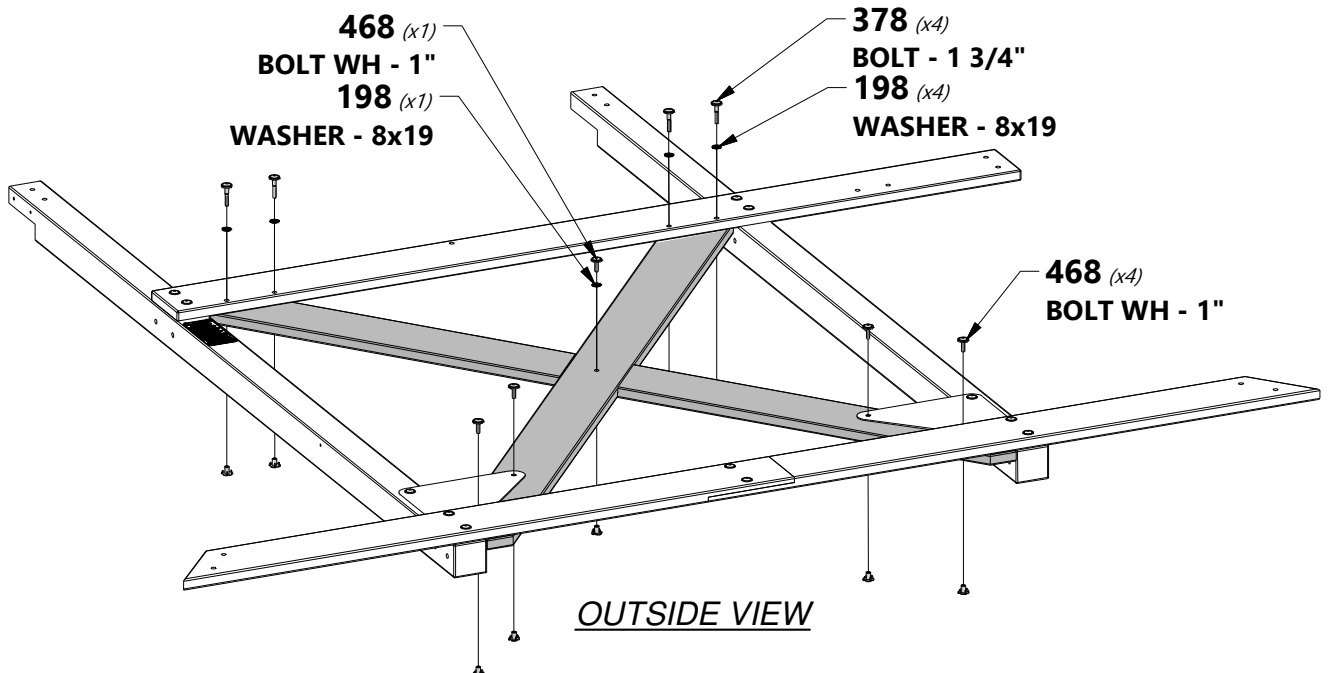
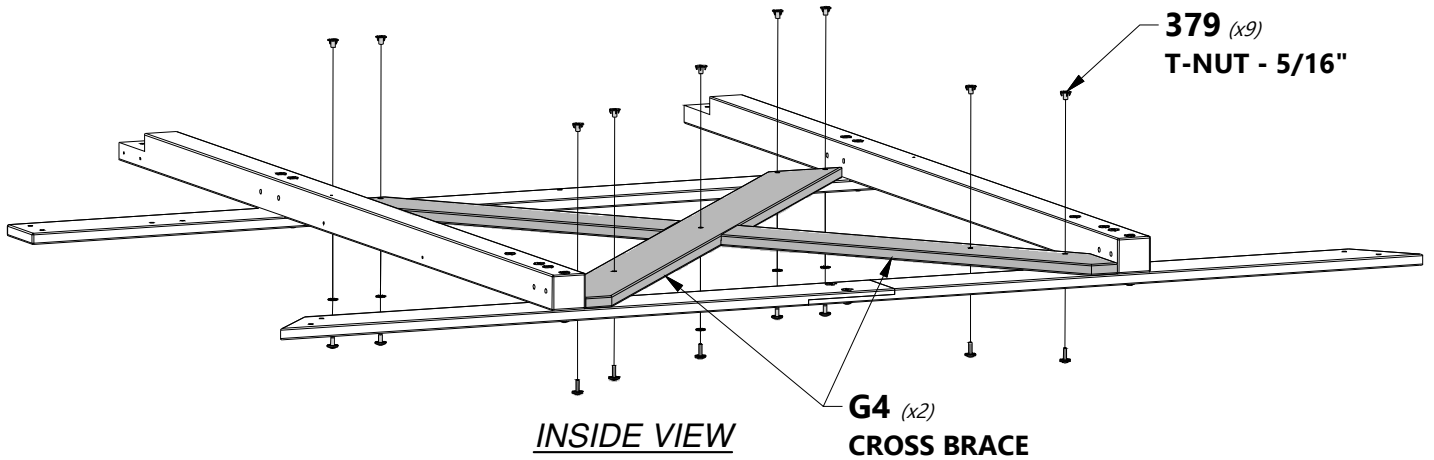

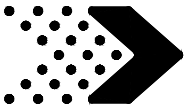

G2 | WALL SUPPORT - W4L12824
(x1) | 1"x5 1/4"x66 5/8" (24x134x1692)



G29 | BASE BOARD - W4L12827
(x1) | 1"x5 1/4"x89 5/8" (24x134x2275)



H100415 | BOLT WH BLK
(x8) | 5/16x3 3/4



H100198 | WASHER LOCK EXT BLK
(x8) | 8x19



H100379 | T-NUT BLK
(x8) | 5/16



TIP:

1. WE RECOMMEND INSTALLING T-NUTS INTO BOARDS BEFORE ASSEMBLY.

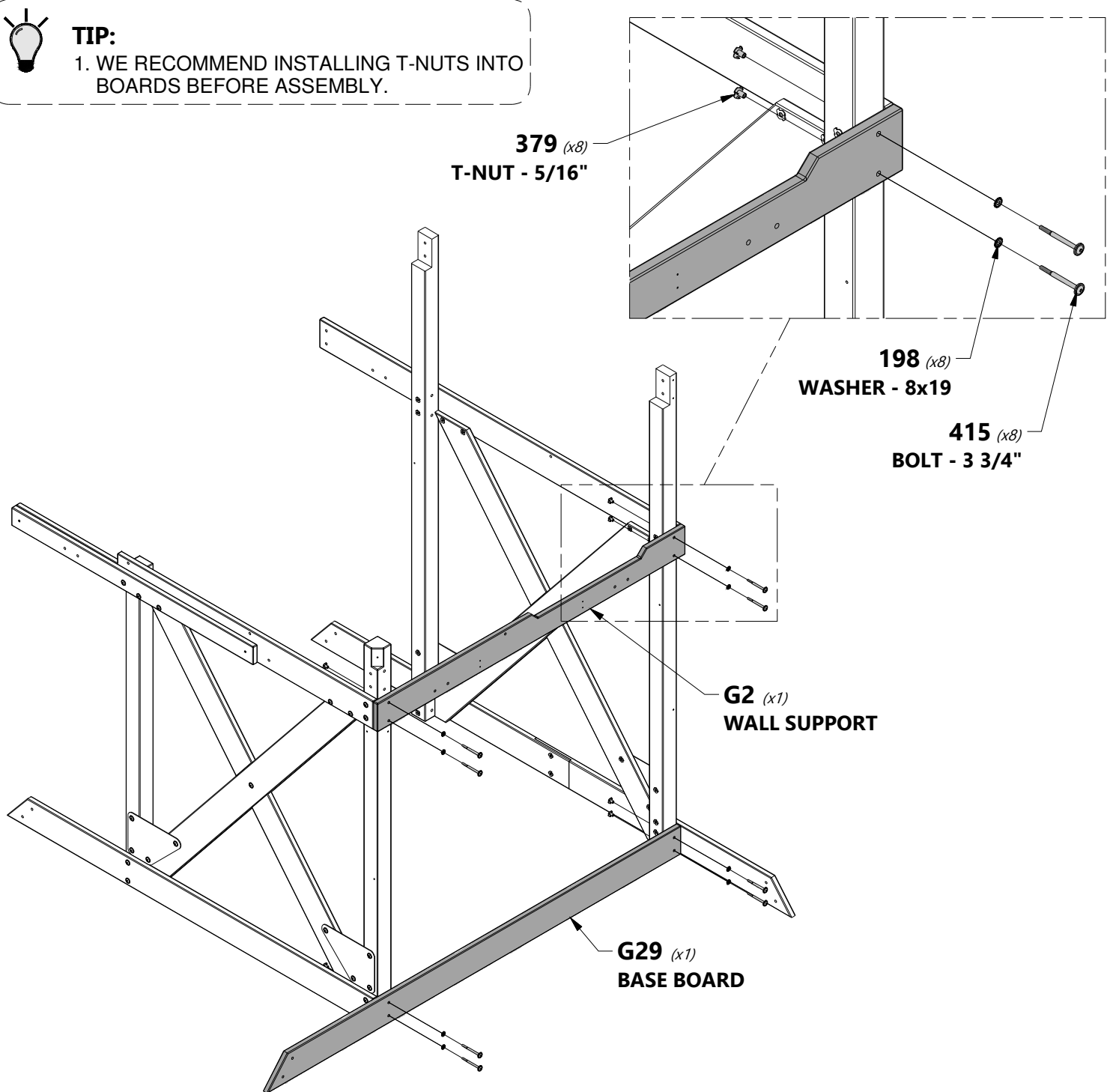

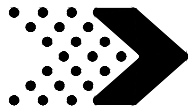

Phase 1

STEP 6

G3 | WALL SUPPORT - W4L12801
(x1) | 1"x5 1/4"x64 3/4" (24x134x1645)

G27 | BASE BOARD - W4L12819
(x1) | 1"x5 1/4"x64 3/4" (24x134x1645)

H23 | FLOOR SUPPORT - W4L12800
(x1) | 1"x3 3/8"x64 3/4" (24x86x1645)

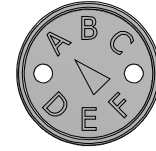

A100314 | "A" REVISION TAG
(x1)

H100480 | BOLT WH BLK
(x2) | 5/16x4 3/4



H100198 | WASHER LOCK EXT BLK
(x7) | 8x19



H100392 | SCREW PWH BLK
(x2) | 8x3/4



H100379 | T-NUT BLK
(x7) | 5/16

H100415 | BOLT WH BLK
(x5) | 5/16x3 3/4



TIP:
WE RECOMMEND INSTALLING
T-NUTS INTO BOARDS BEFORE
ASSEMBLY.

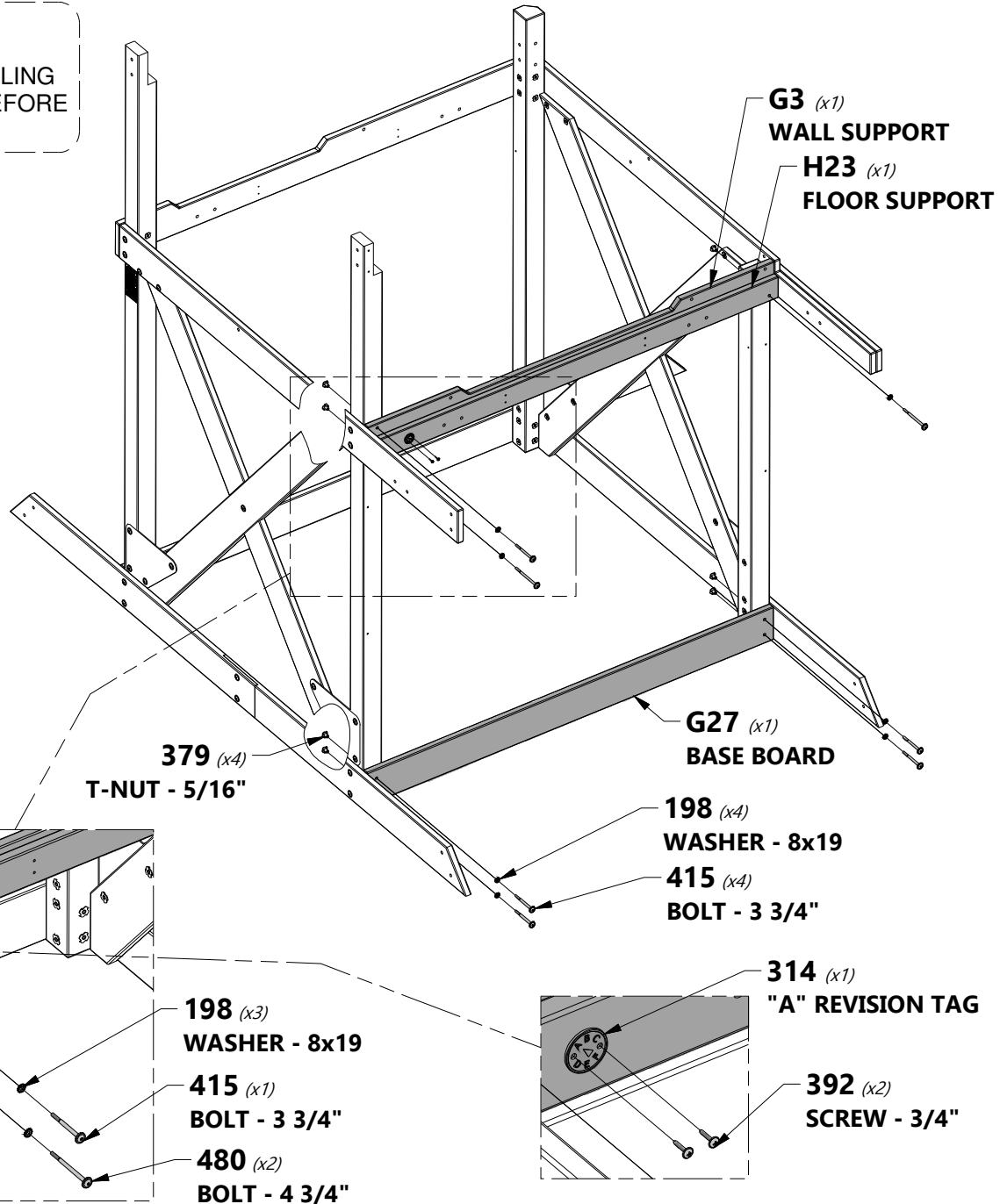

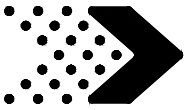

Phase 1

STEP 7

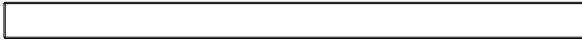

E6 | FLOOR SUPPORT - W4L12807
(x2) | 1 3/8"x3 3/8"x54 3/8" (36x86x1382)



H100362 | SCREW PFH BLK
(x8) | 8x3

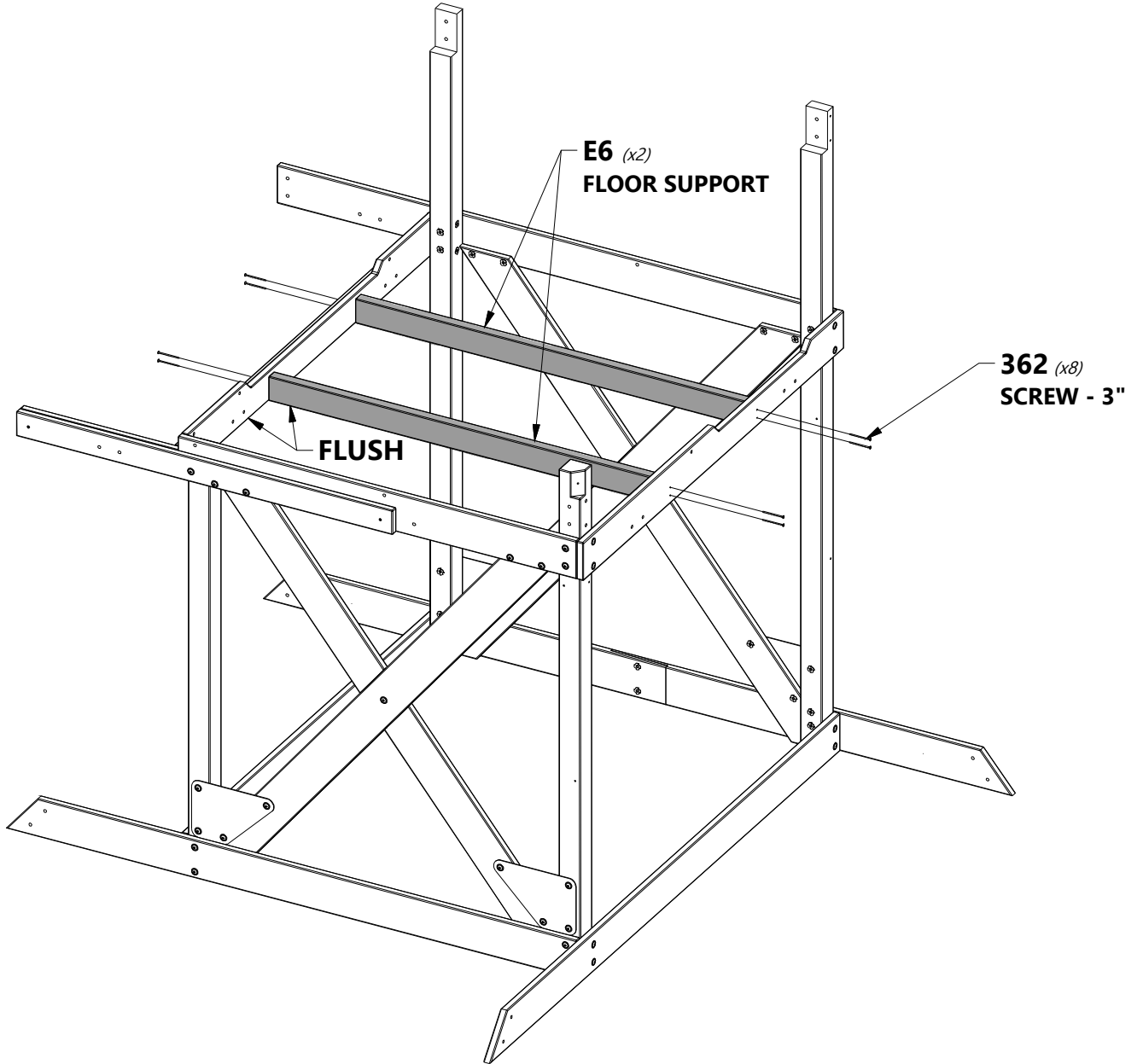

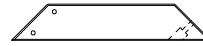
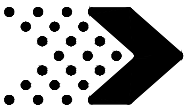

E1 | ANGLE SUPPORT - W4L08458
(x6) 1 3/8"x3 3/8"x18 3/4" (36x86x475)



H100484 | BOLT WH BLK
(x6) 5/16x3 1/4



H100198 | WASHER LOCK EXT BLK
(x18) 8x19



H100205 | BOLT WH BLK
(x6) 5/16x2-1/4



H100379 | T-NUT BLK
(x12) 5/16



H100197 | LAG SCREW WH BLK
(x6) 5/16x2 1/2



TIP:
WE RECOMMEND INSTALLING T-NUTS INTO BOARDS BEFORE ASSEMBLY.
(THE SIDE OF THE SUPPORT THAT ACCEPTS THE T-NUTS VARIES).

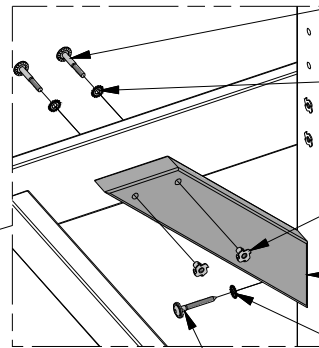

205 (x4)
BOLT - 2 1/4"

198 (x4)
WASHER - 8x19

379 (x4)
T-NUT - 5/16"

E1 (x6)
ANGLE SUPPORT

198 (x2)
WASHER - 8x19

197 (x2)
LAG SCREW - 2 1/2"

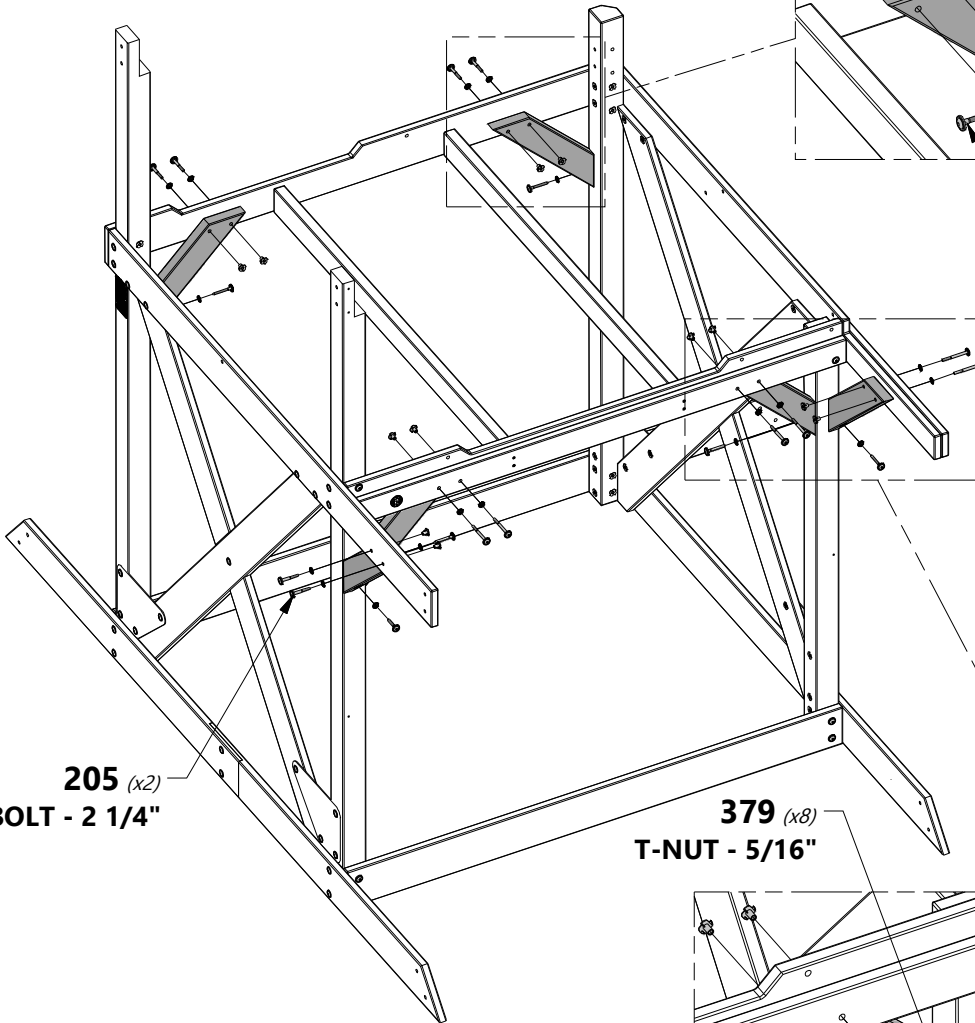

205 (x2)
BOLT - 2 1/4"

379 (x8)
T-NUT - 5/16"

484 (x4)
BOLT - 3 1/4"

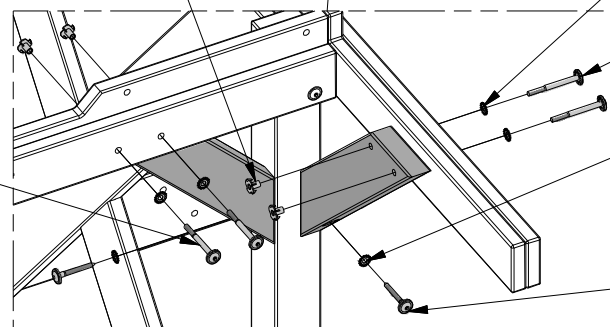

198 (x8)
WASHER - 8x19

484 (x2)
BOLT - 3 1/4"

198 (x4)
WASHER - 8x19

197 (x4)
LAG SCREW - 2 1/2"

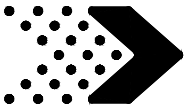

Phase 1

STEP 9



E7 | **ANGLE BRACE - W4L08494**
(x4) | 1 3/8"x3 3/8"x38 1/2" (36x86x978)



H100205 | **BOLT WH BLK**
(x8) | 5/16x2-1/4



H100197 | **LAG SCREW WH BLK**
(x4) | 5/16x2 1/2



H100198 | **WASHER LOCK EXT BLK**
(x12) | 8x19



H100379 | **T-NUT BLK**
(x8) | 5/16



TIP:

WE RECOMMEND INSTALLING T-NUTS INTO BOARDS BEFORE ASSEMBLY.

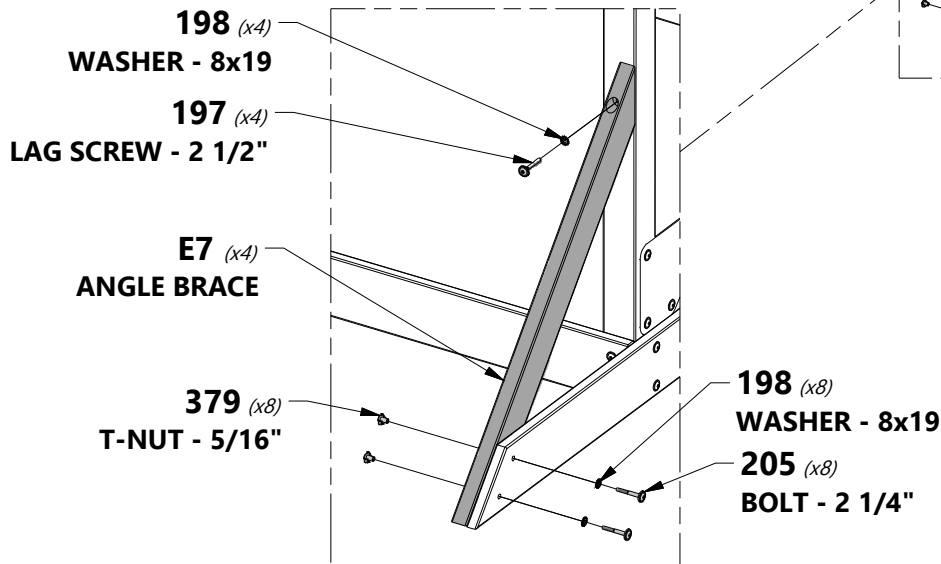
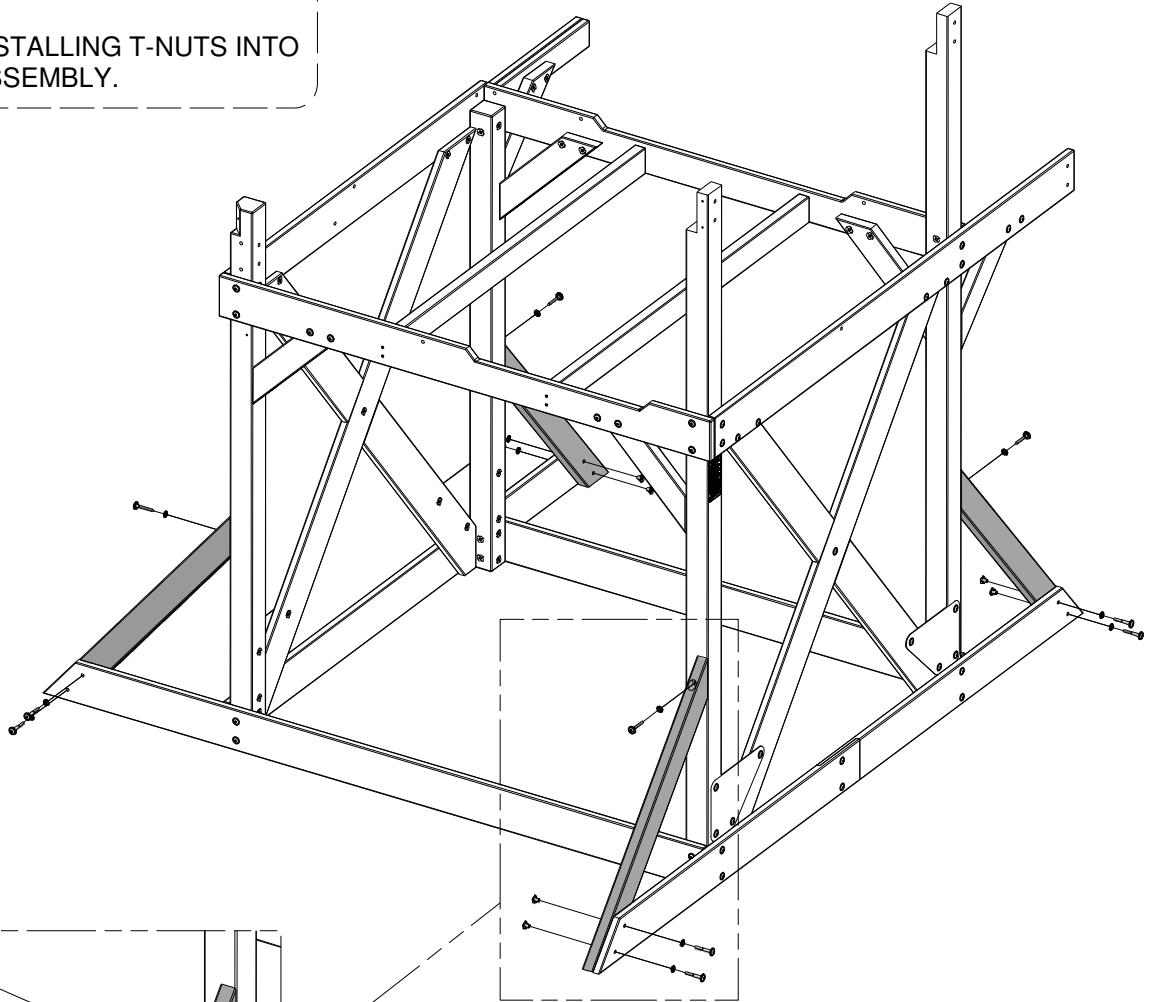

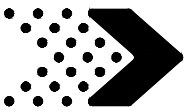

Phase 1

STEP 10

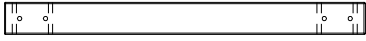

B17 | POST - W4L08696
(x1) | 3"x3"x33 7/8" (76x76x860)



H100415 | BOLT WH BLK
(x2) | 5/16x3 3/4



H100198 | WASHER LOCK EXT BLK
(x2) | 8x19



H100379 | T-NUT BLK
(x2) | 5/16



TIP:
WE RECOMMEND INSTALLING T-NUTS
INTO BOARDS BEFORE ASSEMBLY.

NOTE HOLE ORIENTATION.

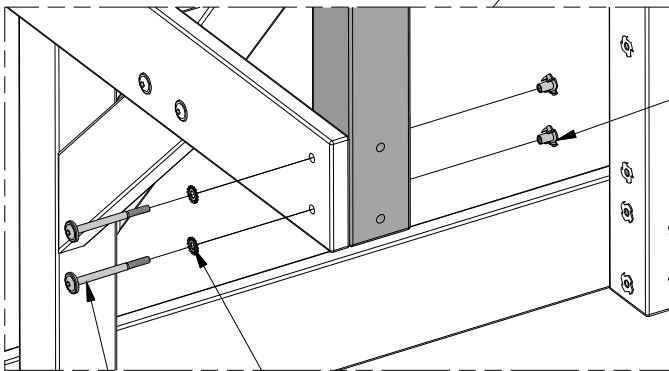
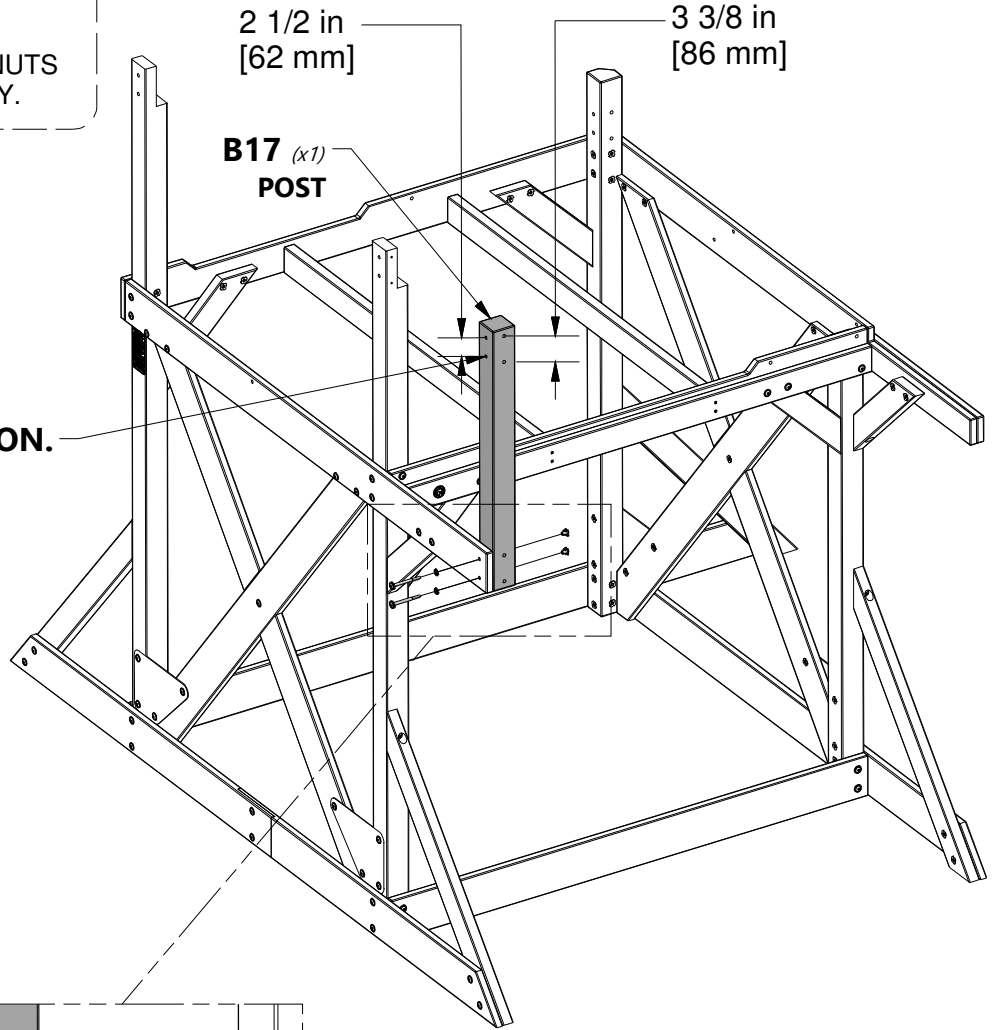

379 (x2)
T-NUT - 5/16"

198 (x2)
WASHER - 8x19
415 (x2)
BOLT - 3 3/4"

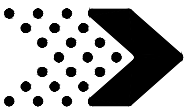

Phase 1

STEP 11

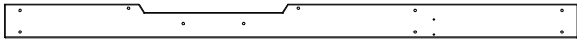

G20 | DECK BOARD - W4L12803
(x1) | 1"x5 1/4"x89 5/8" (24x134x2276)



H100391 | SCREW PFH BLK
(x2) | 8x2



H100415 | BOLT WH BLK
(x2) | 5/16x3 3/4



H100198 | WASHER LOCK EXT BLK
(x2) | 8x19



H100379 | T-NUT BLK
(x2) | 5/16



TIP:

WE RECOMMEND INSTALLING T-NUTS INTO BOARDS BEFORE ASSEMBLY.

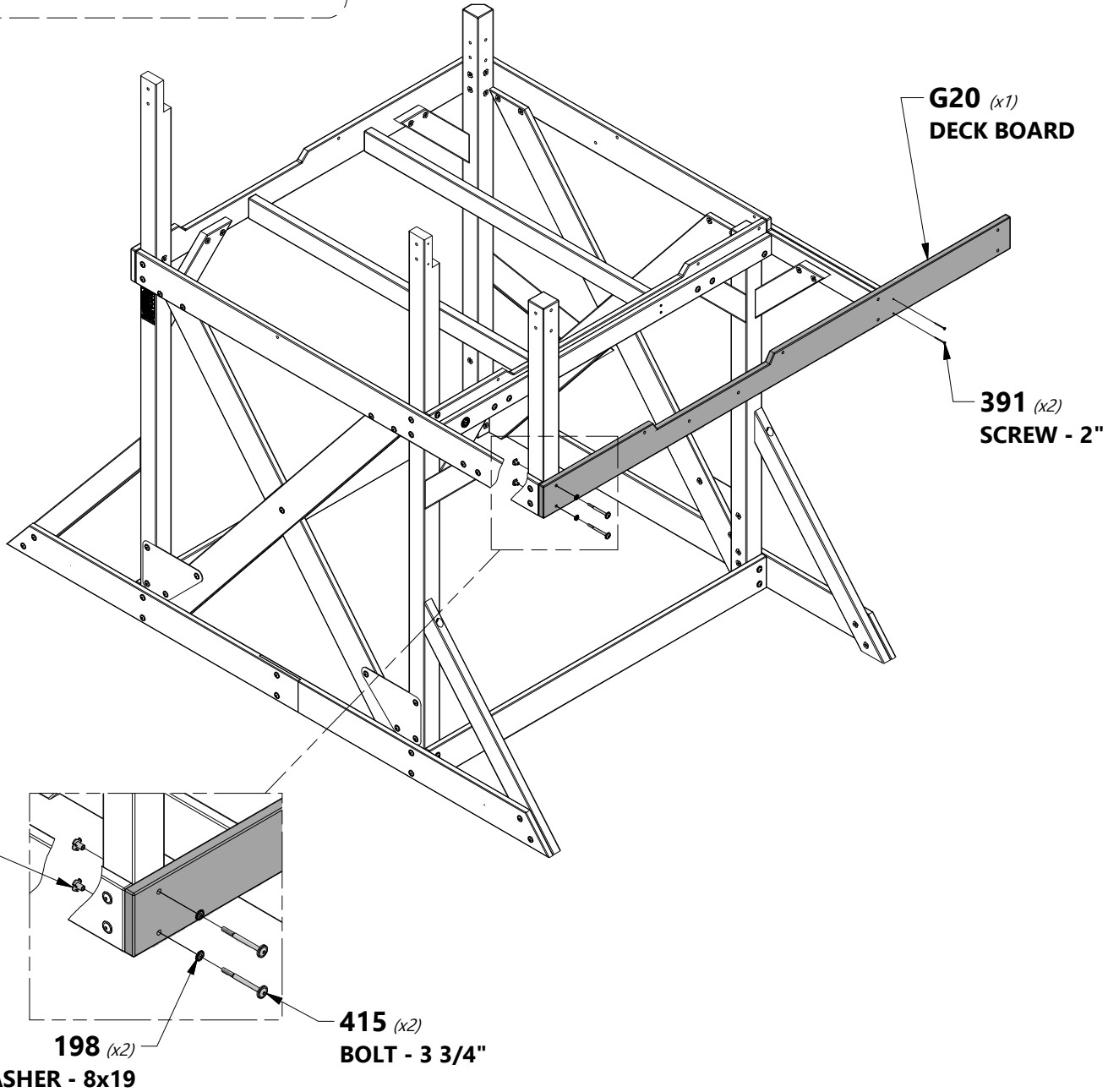

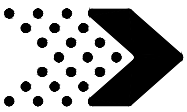

Phase 1

STEP 12



B17 | POST - W4L08696
(x1) | 3"x3"x33 7/8" (76x76x860)



B19 | POST - W4L12828
(x1) | 3"x3"x33 7/8" (76x76x860)



H100415 | BOLT WH BLK
(x4) | 5/16x3 3/4



H100198 | WASHER LOCK EXT BLK
(x4) | 8x19



H100379 | T-NUT BLK
(x4) | 5/16



TIP:
WE RECOMMEND INSTALLING T-NUTS INTO BOARDS BEFORE ASSEMBLY.

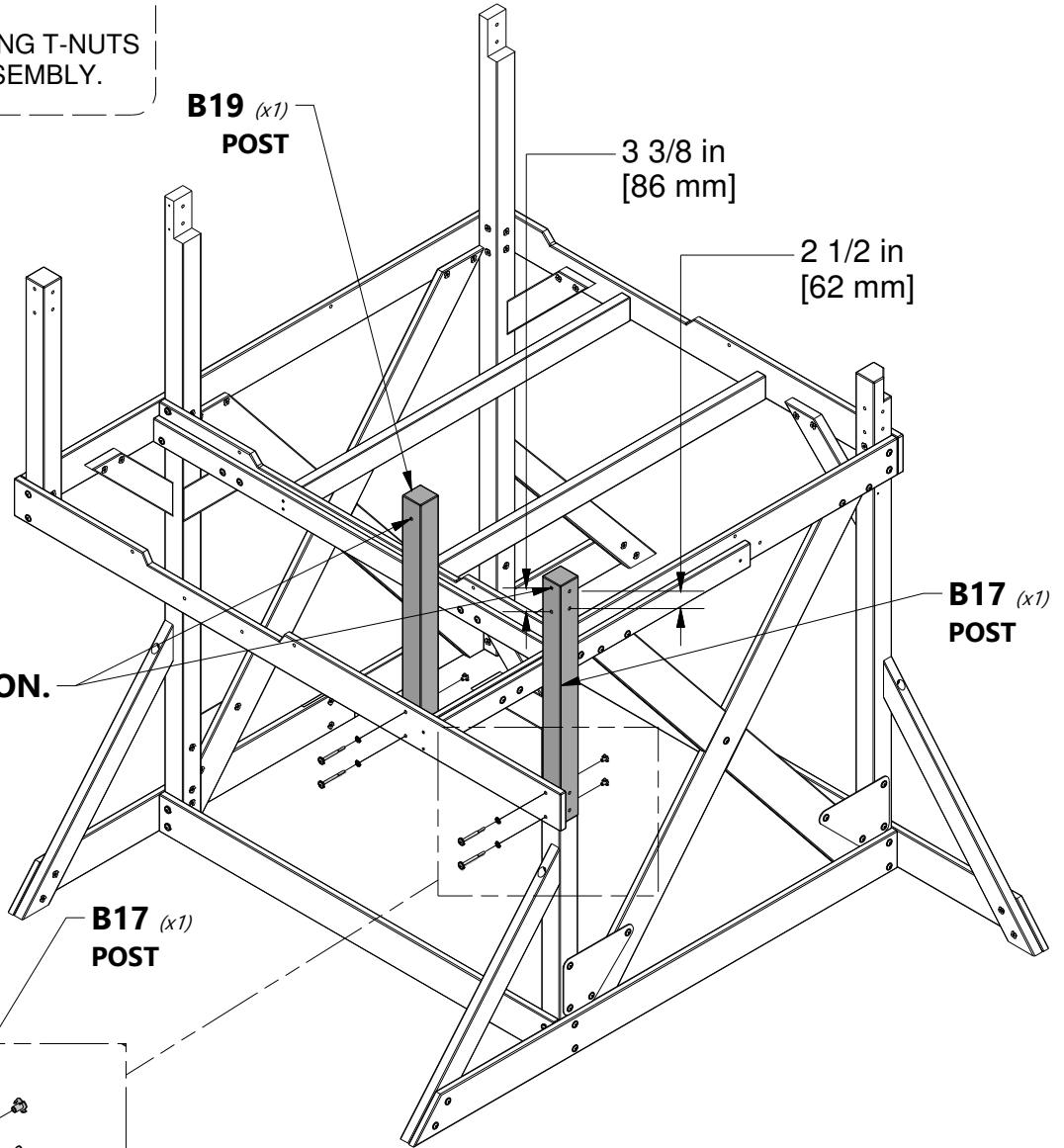

NOTE HOLE ORIENTATION.

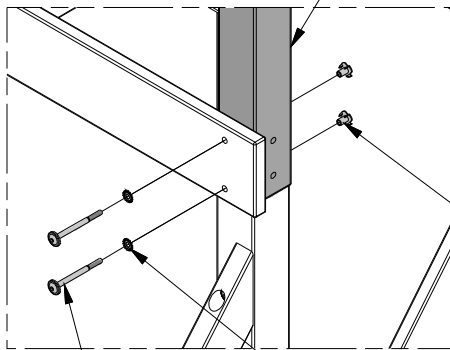

415 (x4)
BOLT - 3 3/4"

198 (x4)
WASHER - 8x19

379 (x4)
T-NUT - 5/16"

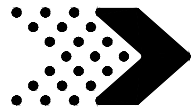

Phase 1

STEP 13

G23 | DECK BOARD - W4L08698
(x1) | 1"x5 1/4"x22" (24x134x560)

2 1/8 in
[55 mm]
A4M00615 | L BRACKET BLK
(x1)
2 in
[50 mm]

H100396 | BOLT WH BLK
(x2) | 5/16x1/2

H100192 | NUT BARREL WH BLK
(x2) | 5/16x7/8

H100199 | WASHER LOCK EXT BLK
(x2) | 12x19



NOTE:
ASSEMBLE THE SUB ASSEMBLY FIRST.



TIP:
WE RECOMMEND INSTALLING T-NUTS INTO BOARDS BEFORE ASSEMBLY.

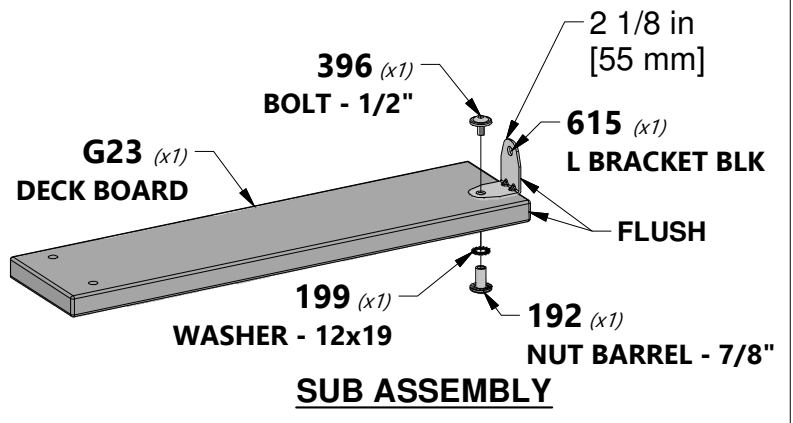

192 (x1)
NUT BARREL - 7/8"

199 (x1)
WASHER - 12x19

396 (x1)
BOLT - 1/2"

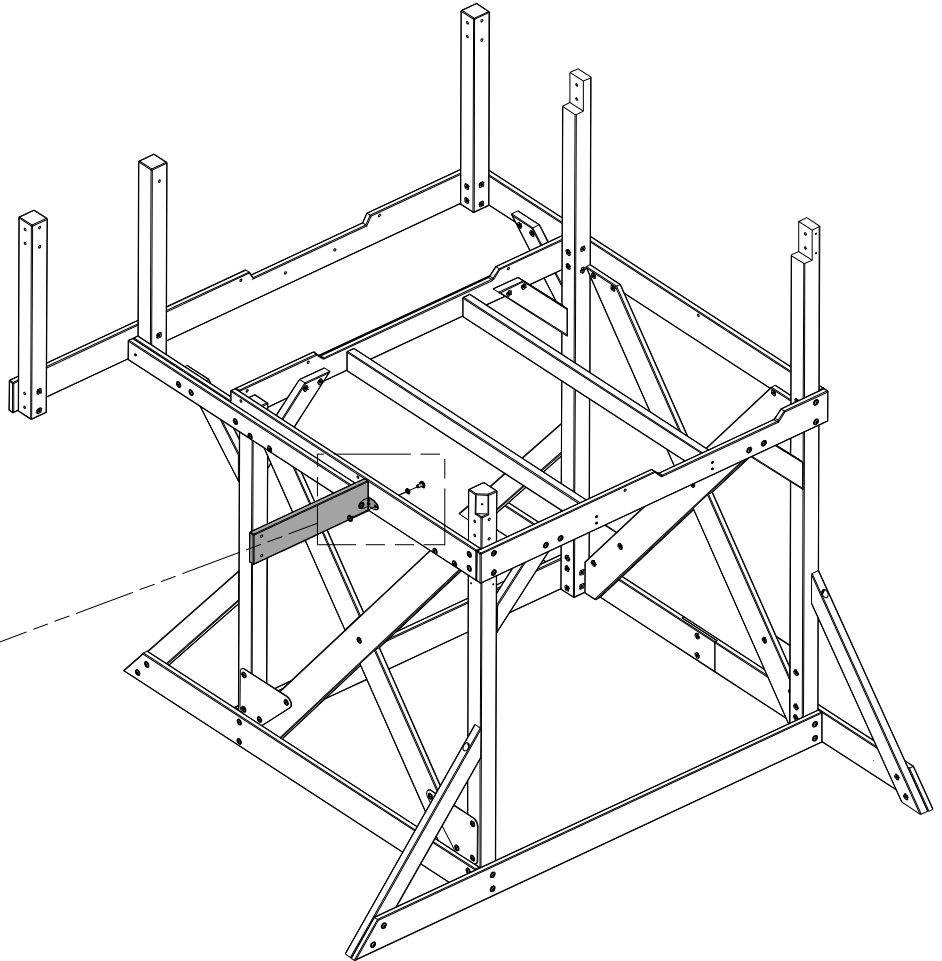

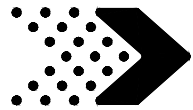

Phase 1

STEP 14



B21 | POST - W4L08746
(x1) | 3"x3"x33 7/8" (76x76x860)



H100415 | BOLT WH BLK
(x2) | 5/16x3 3/4



H100198 | WASHER LOCK EXT BLK
(x2) | 8x19



H100379 | T-NUT BLK
(x2) | 5/16



TIP:
WE RECOMMEND INSTALLING T-NUTS INTO BOARDS BEFORE ASSEMBLY.

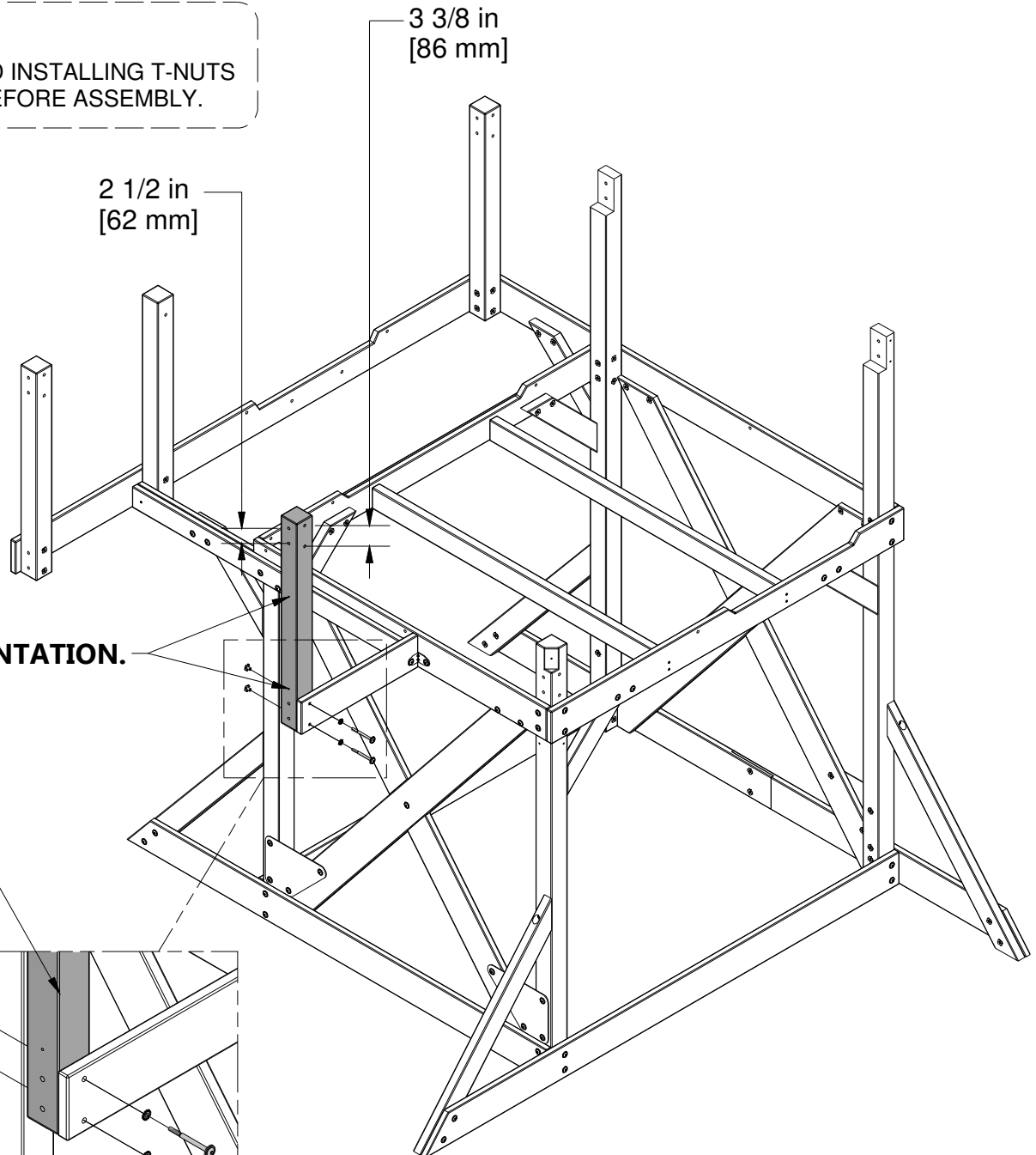

NOTE HOLE ORIENTATION.

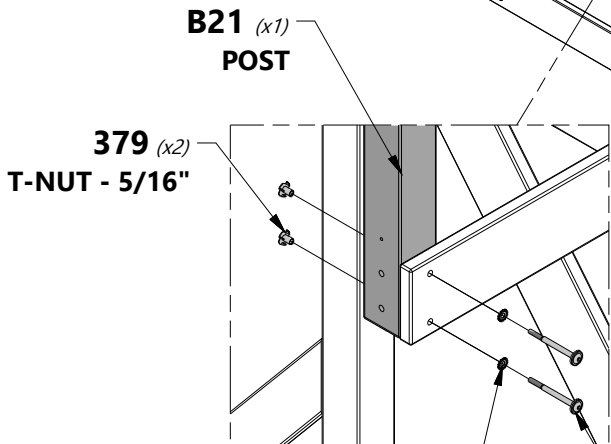

B21 (x1)
POST

379 (x2)
T-NUT - 5/16"

198 (x2)
WASHER - 8x19

415 (x2)
BOLT - 3 3/4"

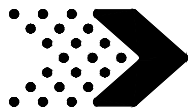

Phase 1

STEP 15

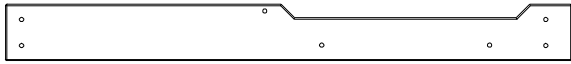

G22 | DECK RAIL - W4L12816
(x1) | 1"x5 1/4"x53 1/8" (24x134x1349)



H100415 | BOLT WH BLK
(x4) | 5/16x3 3/4



H100198 | WASHER LOCK EXT BLK
(x4) | 8x19



H100379 | T-NUT BLK
(x4) | 5/16



TIP:

WE RECOMMEND INSTALLING T-NUTS INTO BOARDS BEFORE ASSEMBLY.

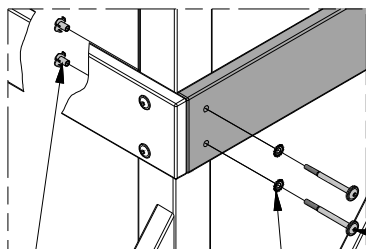
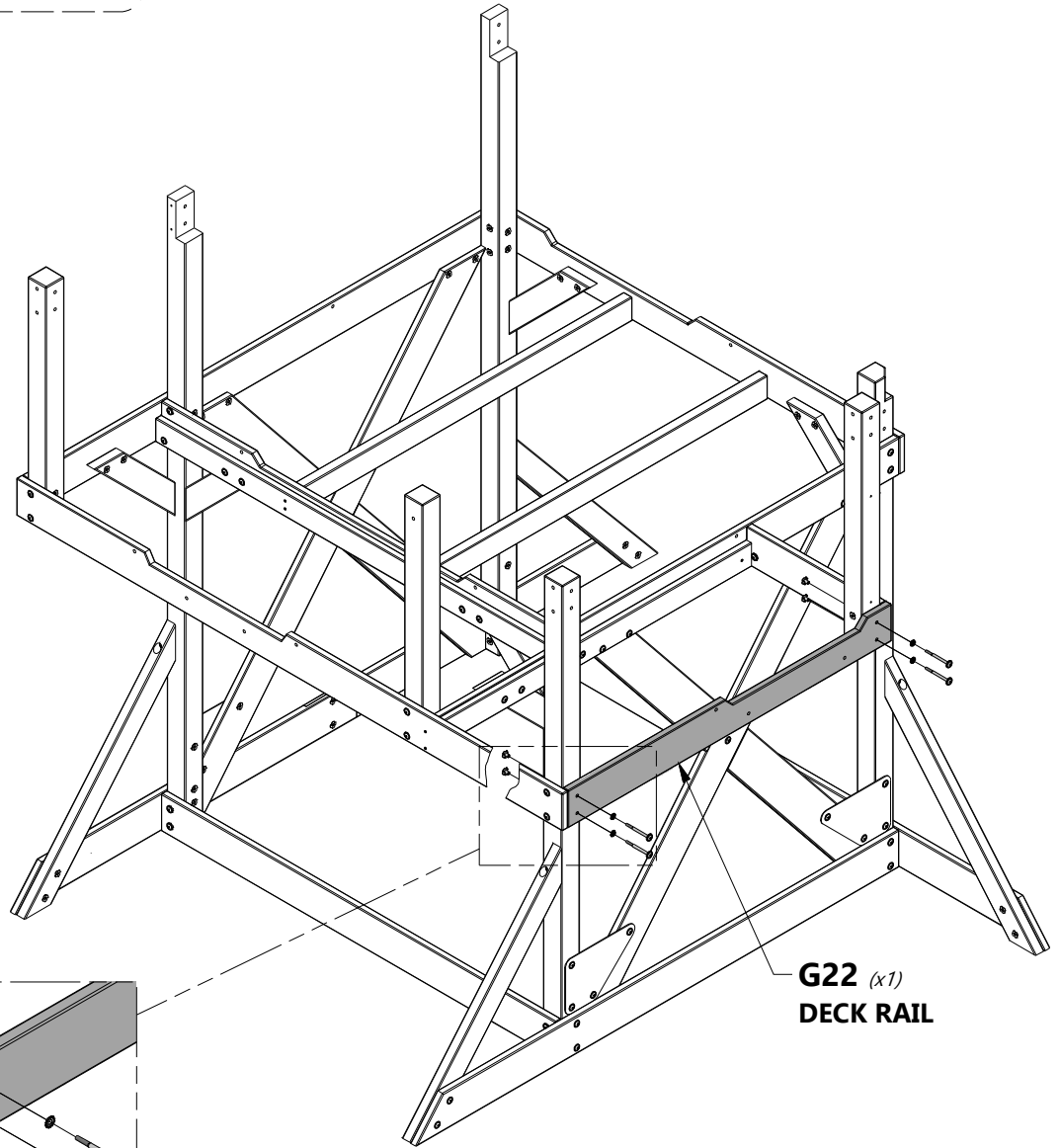

379 (x4)
T-NUT - 5/16"

198 (x4)
WASHER - 8x19

415 (x4)
BOLT - 3 3/4"

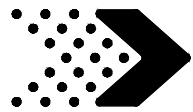

Phase 1

STEP 16



H26 | FLOOR SUPPORT - W4L08700
(x1) | 1"x3 3/8"x46 1/8" (24x86x1172)



H100382 | SCREW PFH BLK
(x4) | 8x1 3/4

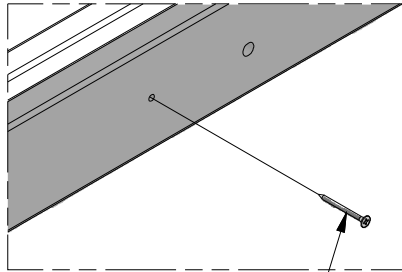

382 (x4)
SCREW - 1 3/4"

LINE UP HOLES.

H26 (x1)
FLOOR SUPPORT

1 7/8 in
[48 mm]
OR FLUSH AT
BOTTOM

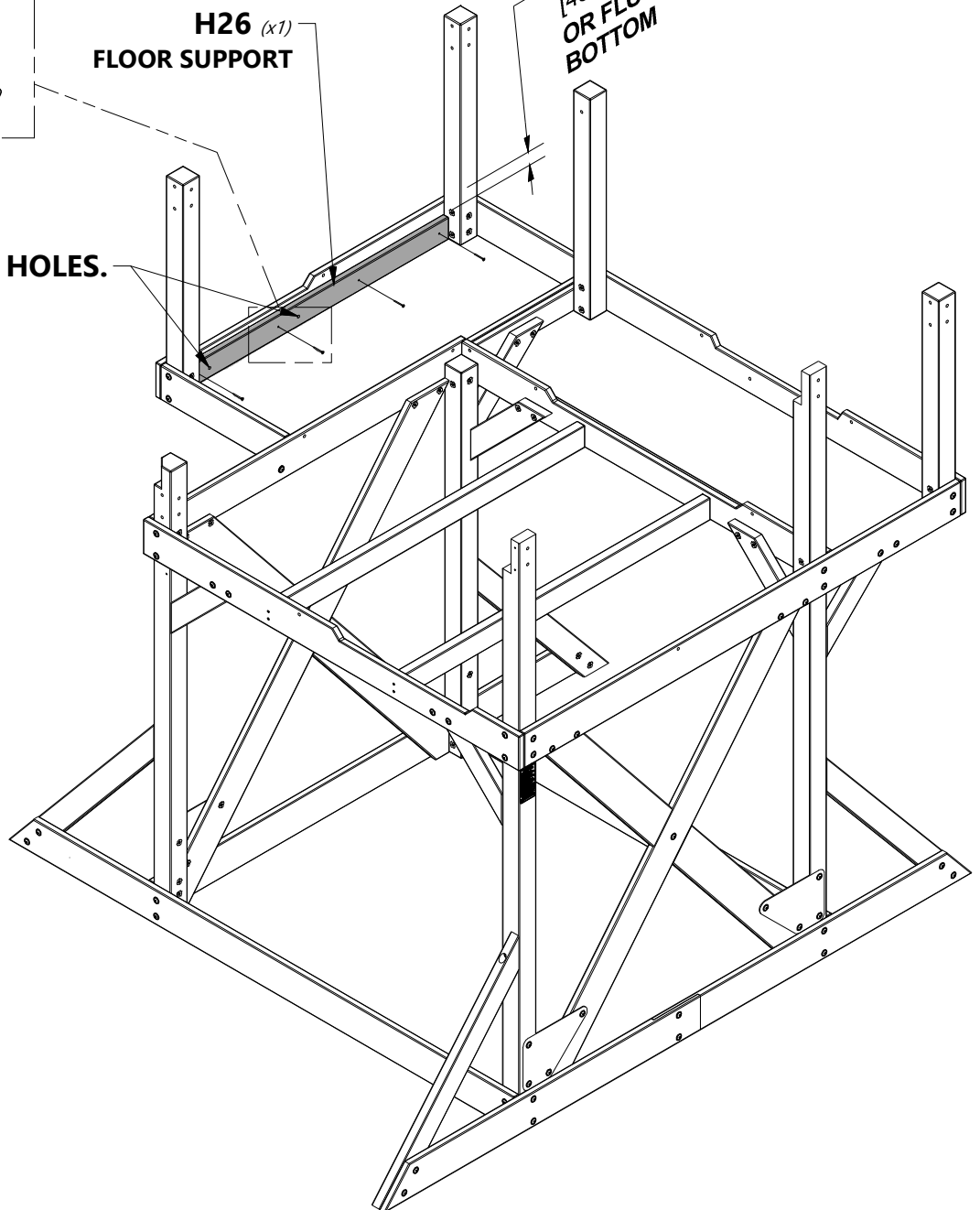

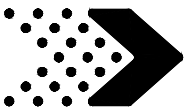

H24 | FLOOR SUPPORT - W4L08571
(x1) | 1"x3 3/8"x58 3/4" (24x86x1493)



H100382 | SCREW PFH BLK
(x4) | 8x1 3/4

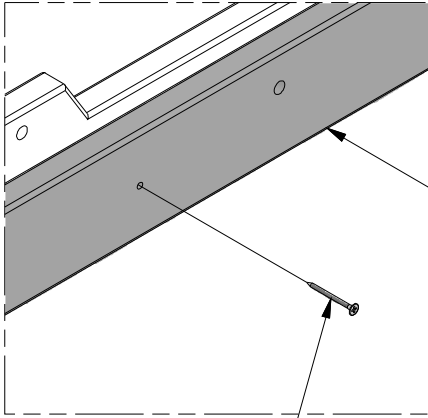

H24 (x1)
FLOOR SUPPORT

1 7/8 in
[48 mm]
OR FLUSH AT
BOTTOM

382 (x4)
SCREW - 1 3/4"

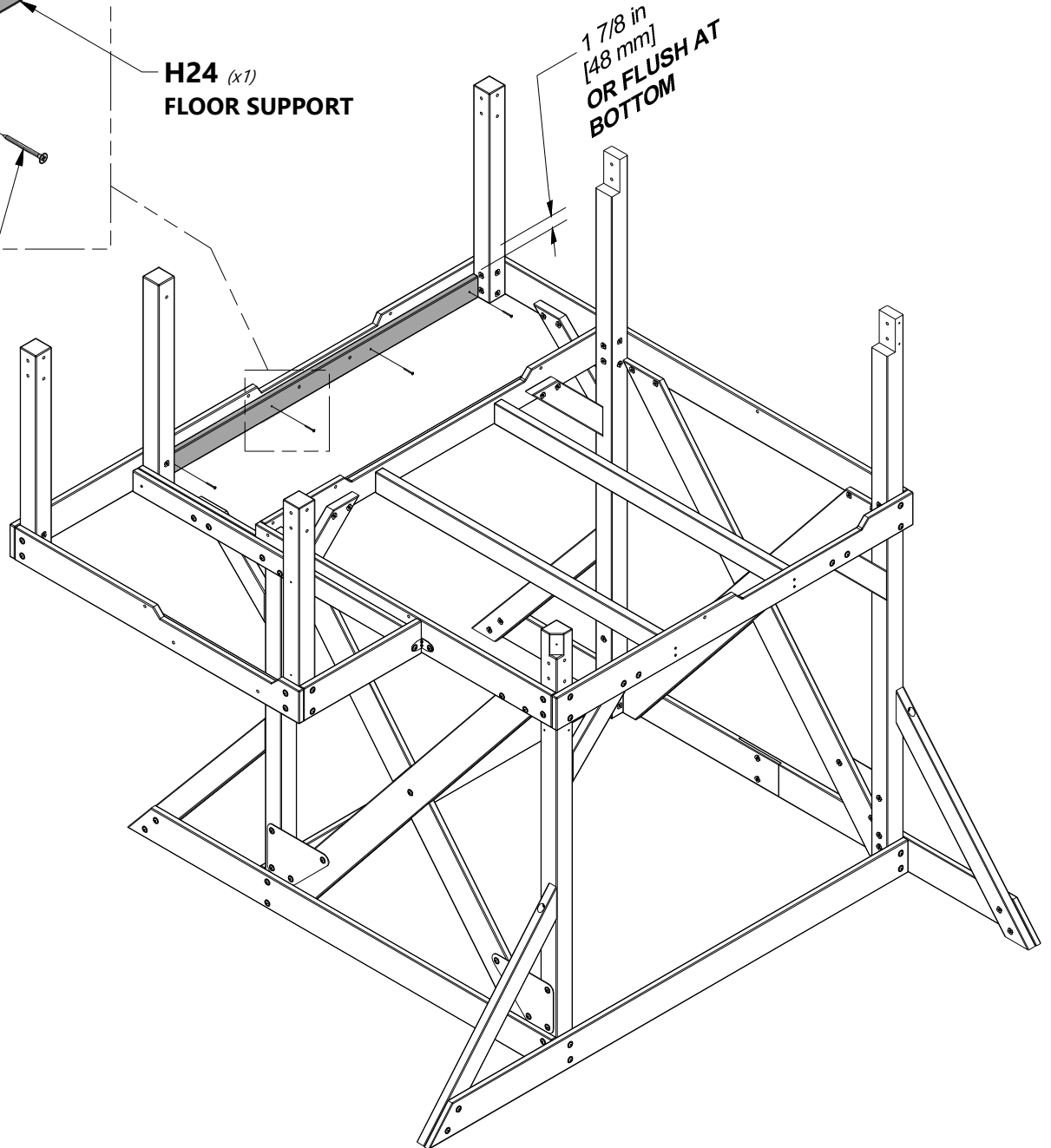

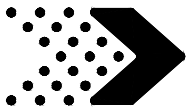

H20 | FLOOR SUPPORT - W4L08562
(x7) | 1"x2 3/4"x3" (24x70x76)



H100391 | SCREW PFH BLK
(x14) | 8x2

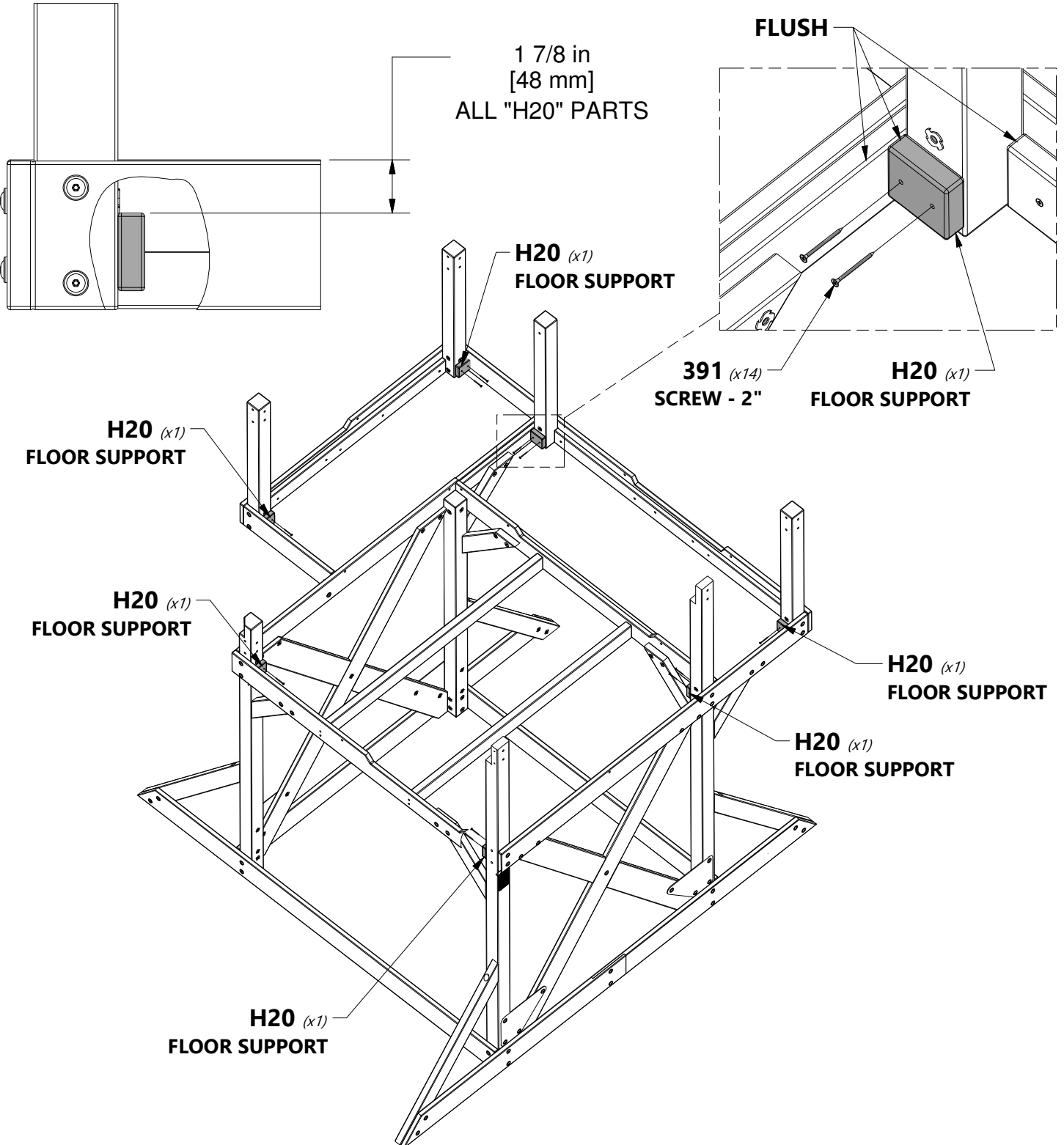

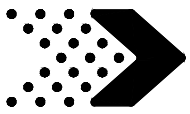

Phase 1

STEP 19



T1 | FLOOR SUPPORT - W4L08466
(x2) | 1"x1 3/8"x48 3/8" (24x34x1230)



H100391 | SCREW PFH BLK
(x8) | 8x2

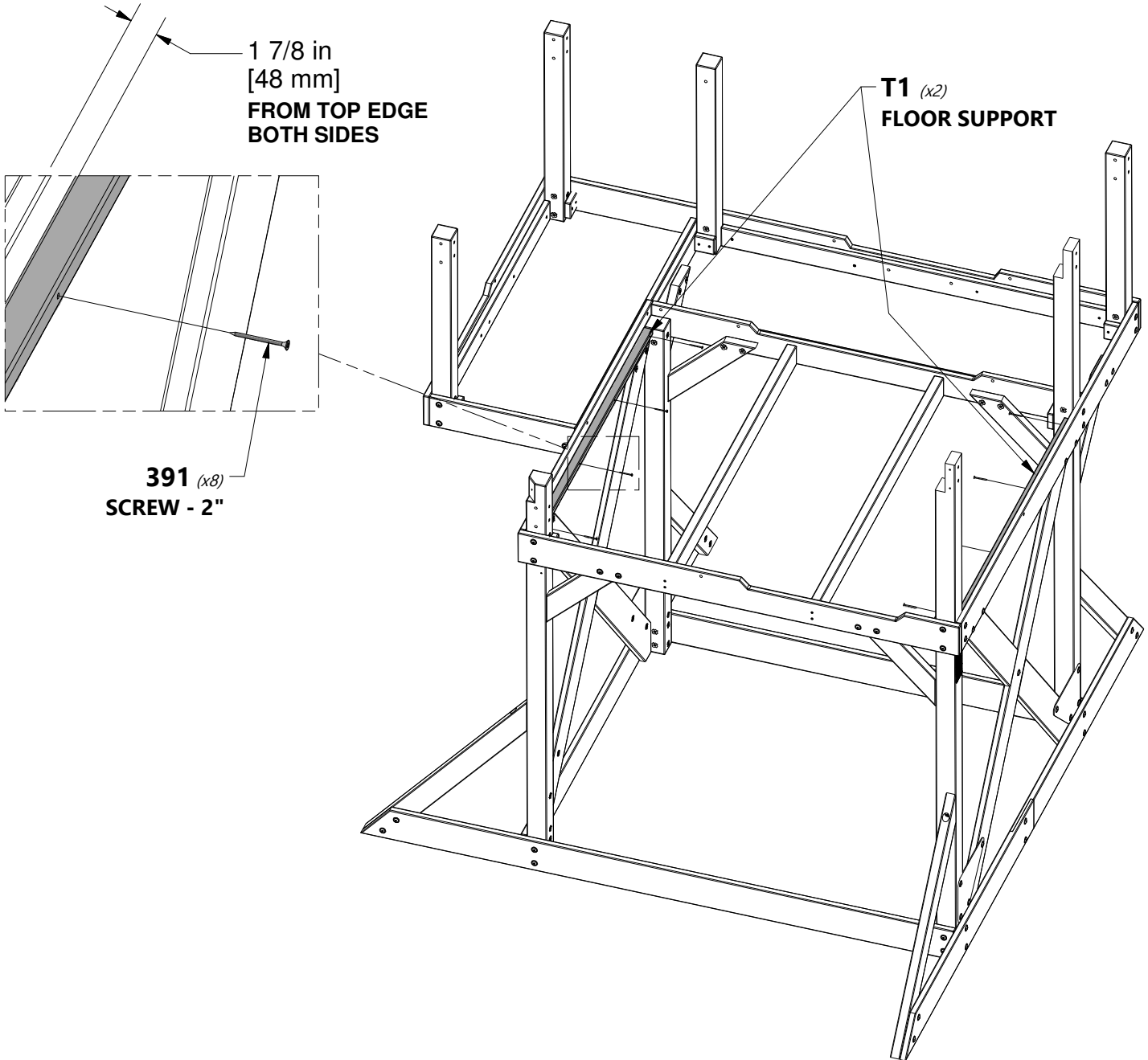

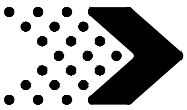

Phase 1

STEP 20

K4 | FLOOR BOARD - W4L12808
(x1) | 5/8"x5"x64 3/4" (16x128x1644)

Y1 | FLOOR BOARD - W4L12806
(x1) | 5/8"x4"x64 3/4" (16x102x1644)

Y2 | FLOOR BOARD - W4L12814
(x1) | 5/8"x4"x64 3/4" (16x102x1644)

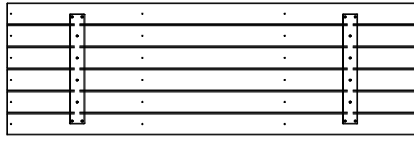

FP1 | FLOOR PANEL - W2A02900
(x2) | 1 1/4"x20 9/16"x65 11/16" (32x523x1644)



H100200 | SCREW PFH BLK
(x72) | 8x1 1/2

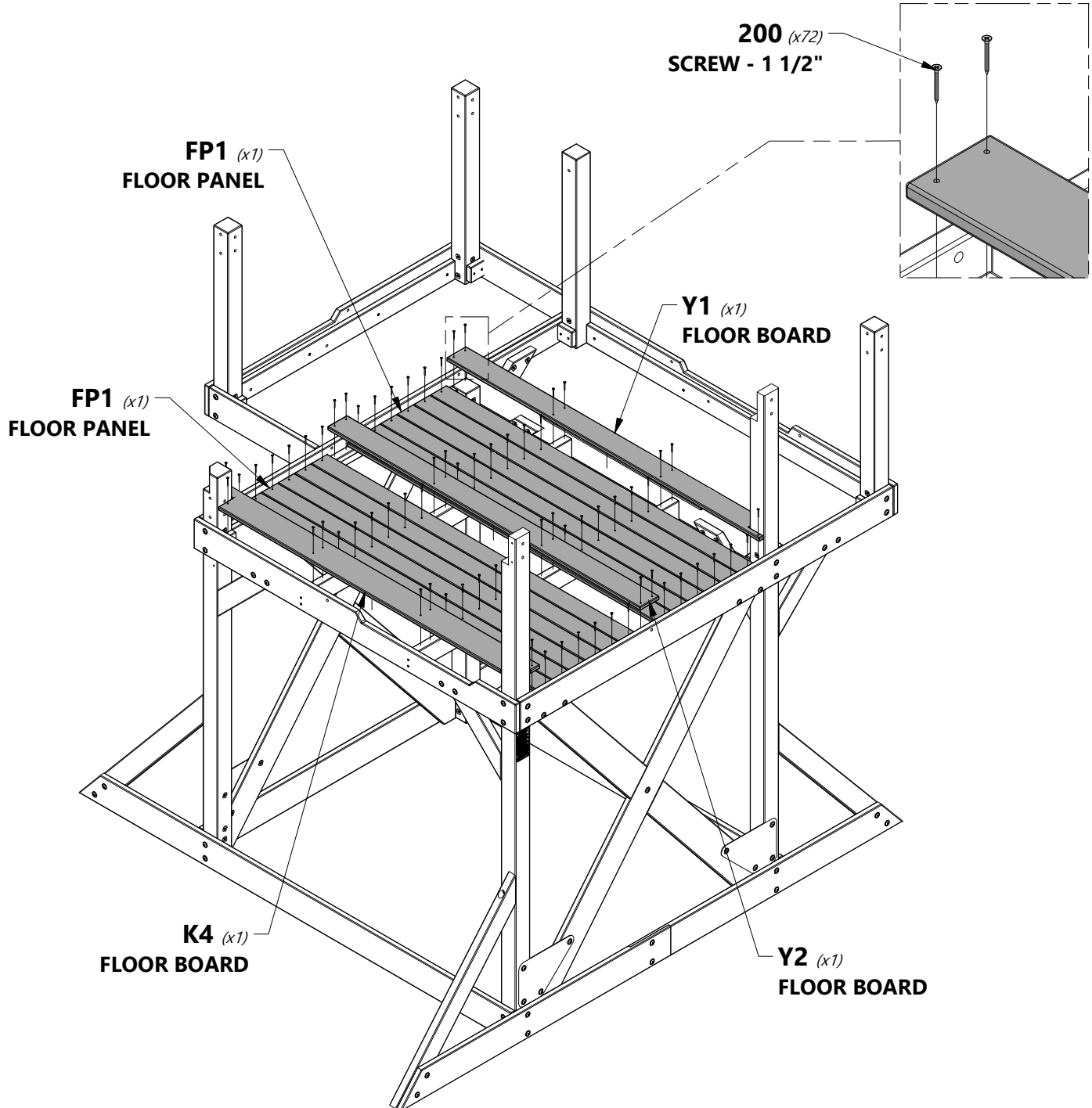

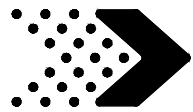

Phase 1

STEP 21



M39 | FLOOR BOARD - W4L11558
(x1) | 5/8"x3"x18 7/8" (16x76x480)

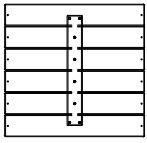

FP3 | FLOOR PANEL - W2A02227
(x2) | 1 1/4"x22 1/16"x20 11/16" (32x555x525)

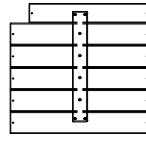

FP4 | FLOOR PANEL - W2A02228
(x1) | 1 1/4"x20 1/4"x22" (32x515x555)



H100200 | SCREW PFH BLK
(x38) | 8x1 1/2

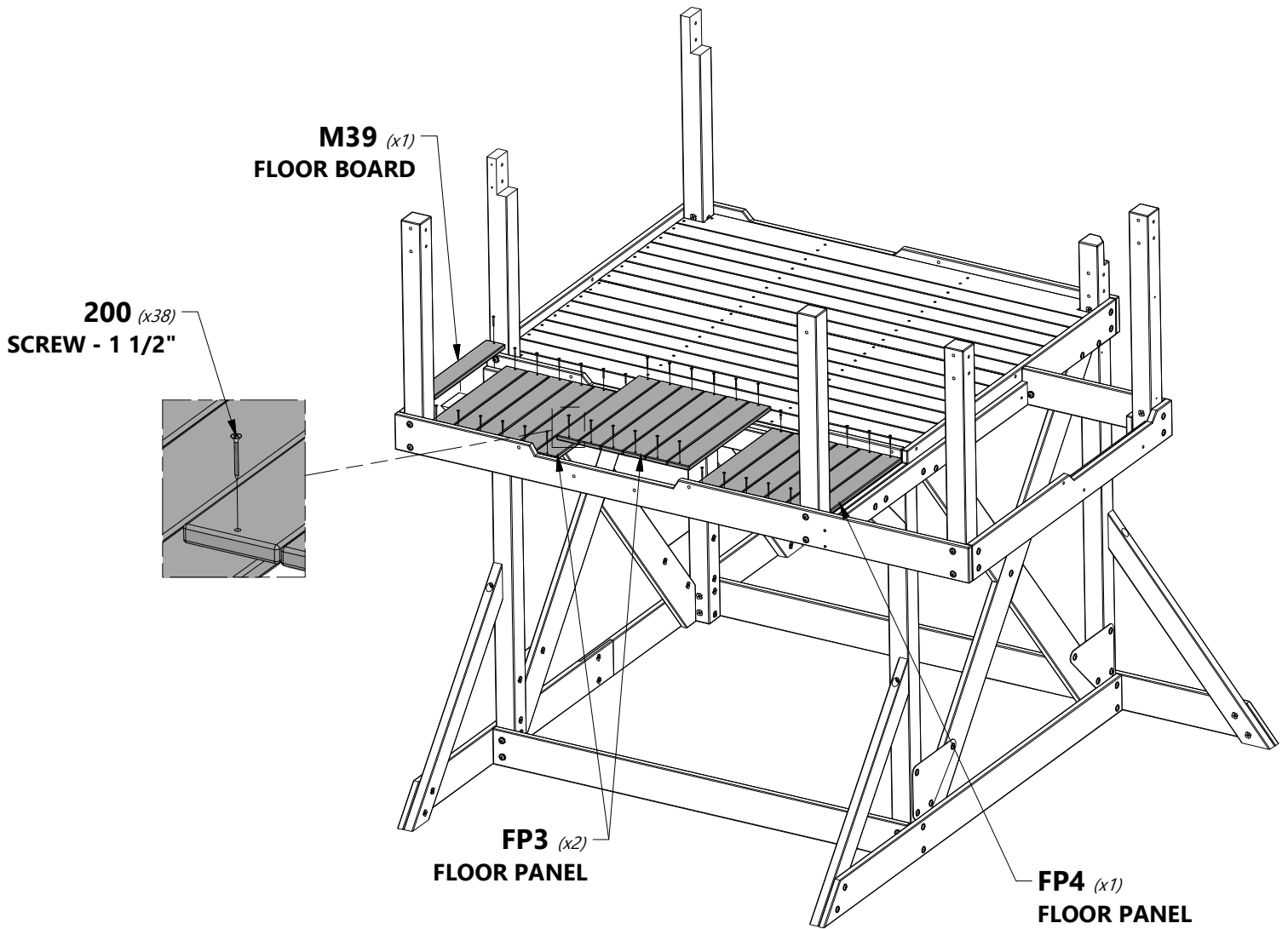

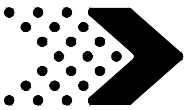

Phase 1

STEP 22

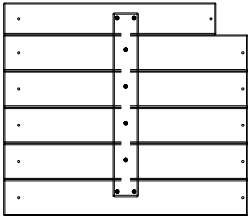

FP5 | FLOOR PANEL - W2A02229
(x1) | 1 1/4"x19 15/16"x22 15/16" (32x506x582)

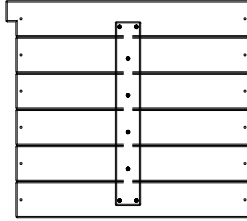

FP6 | FLOOR PANEL - W2A02230
(x1) | 1 1/4"x20 5/16"x22 15/16" (32x516x582)

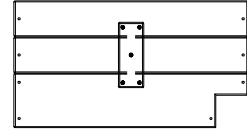

FP7 | FLOOR PANEL - W2A02248
(x1) | 1 1/4"x12 1/16"x22 1/16" (32x302x558)



H100200 | SCREW PFH BLK
(x32) | 8x1 1/2



NOTE:

DO NOT PUT WEIGHT OR WALK ON BALCONY SURFACES UNTIL AFTER PHASE 7 COMPLETION.

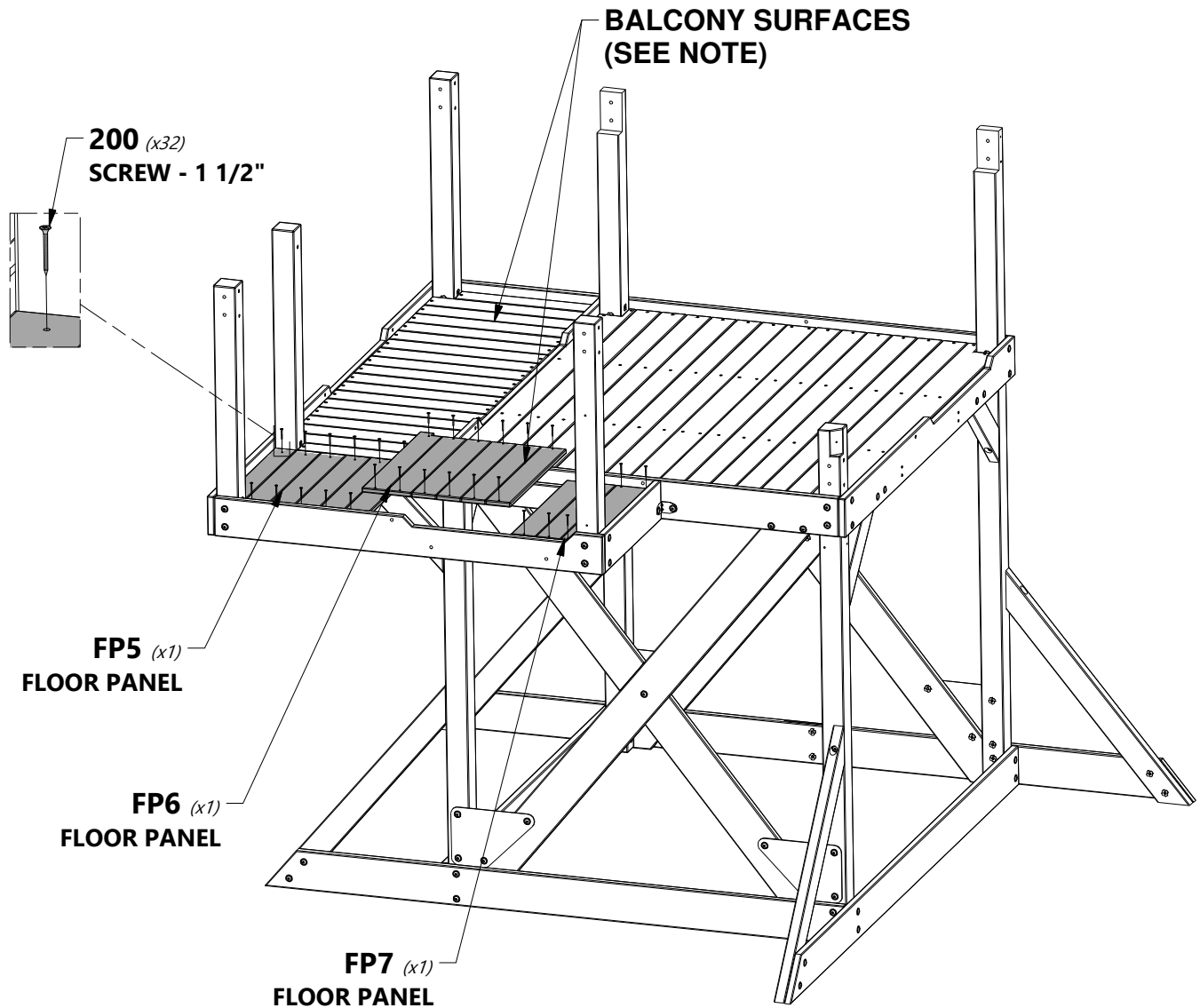

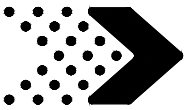

A100178 (x4) METAL GROUND STAKE BROWN



H100171 (x4) BOLT WH BLK 1/4x1



H100404 (x4) NUT BARREL WH BLK 1/4x5/8



H100474 (x4) WASHER FLAT BLK 9x18



H100400 (x4) WASHER LOCK EXT BLK 8x15

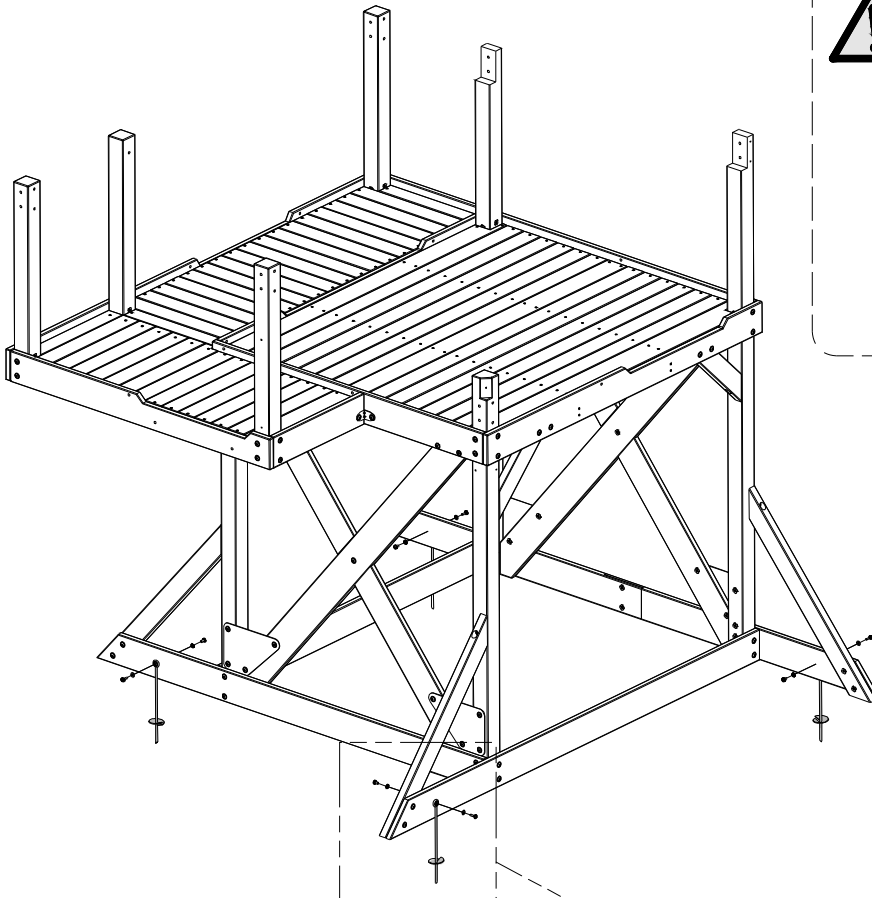

NOTE:

1. SCREW THE AUGER INTO THE GROUND NEXT TO THE GROUND BOARD.
2. USING THE EYELET OF THE AUGER AS A TEMPLATE, DRILL A 5/16" [8 mm] HOLE THROUGH THE GROUND BOARD.
3. USE HARDWARE PROVIDED TO SECURE AUGERS TO GROUND BOARDS.



NOTE:

FAILURE TO USE GROUND STAKES CAN VOID WARRANTY AND CAUSE INJURY!

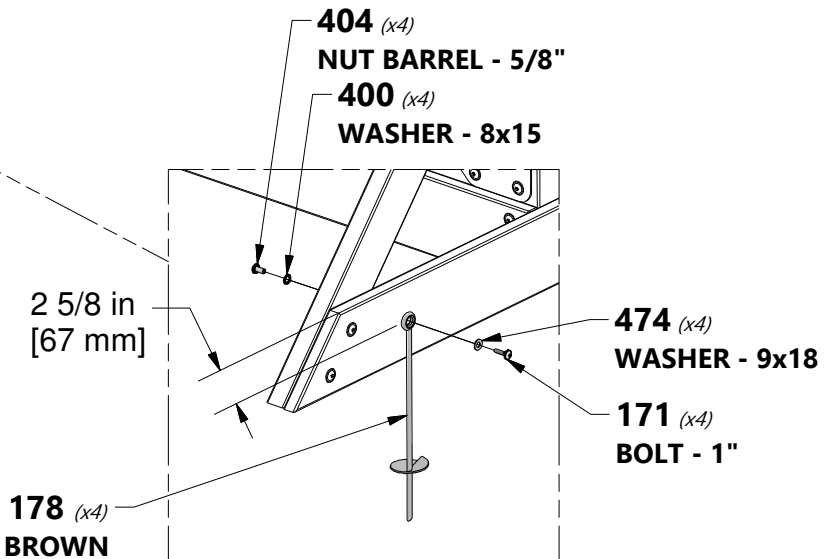

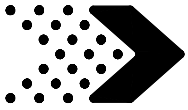

Phase 2

STEP 1

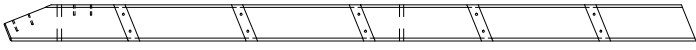

E77 | LEFT UPRIGHT - W4L12840
(x1) | 1 3/8"x3 3/8"x64 7/8" (36x86x1649)

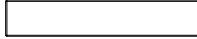

H76 | LADDER RUNG - W4L06609
(x5) | 1"x3 3/8"x18 1/8" (24x86x460)



H100391 | SCREW PFH BLK
(x10) | 8x2

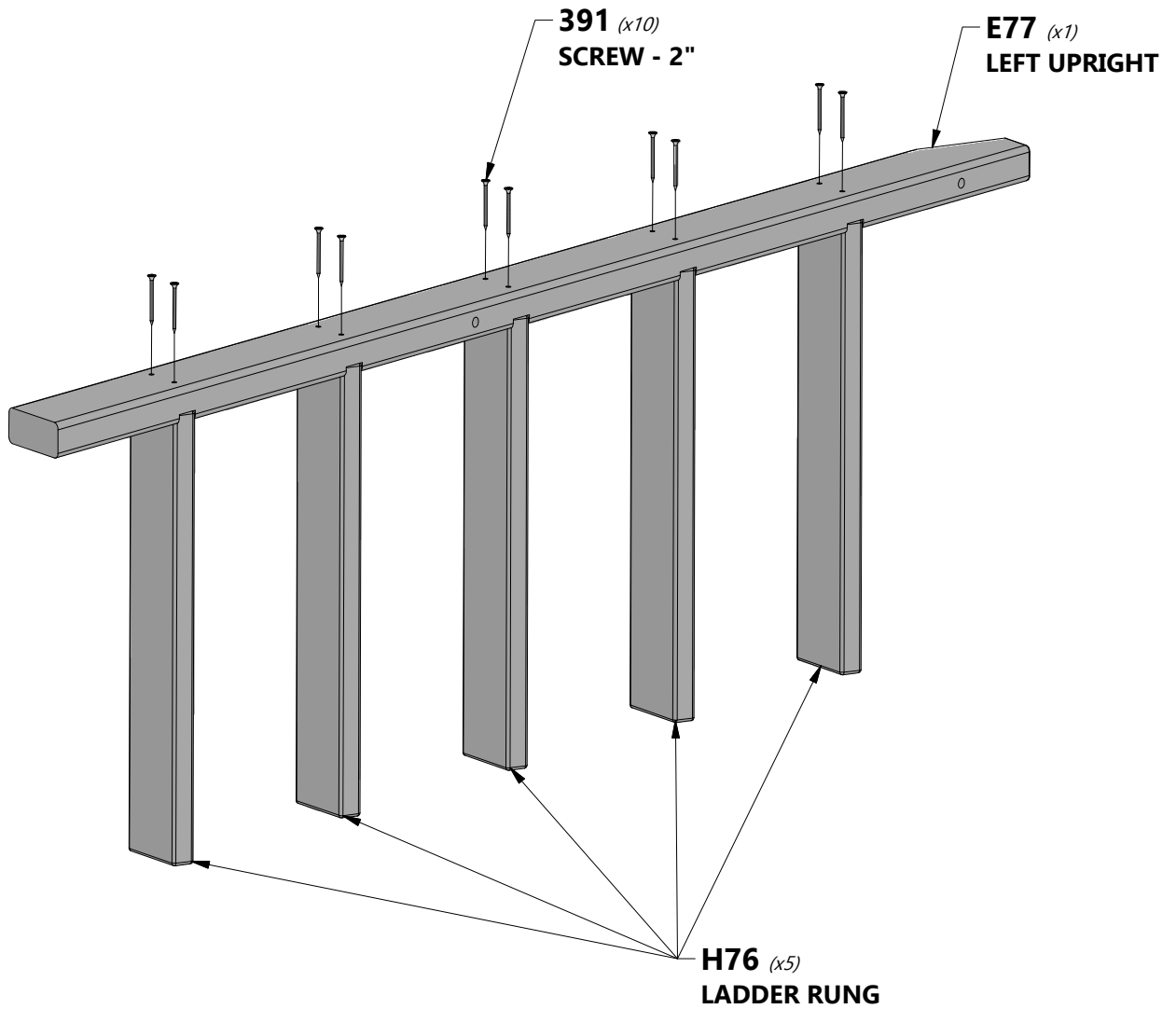

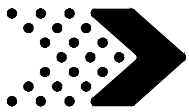

Phase 2

STEP 2

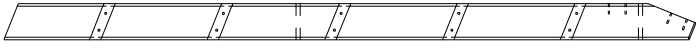

E78 | RIGHT UPRIGHT - W4L12841
(x1) | 1 3/8"x3 3/8"x64 7/8" (36x86x1649)



H100391 | SCREW PFH BLK
(x10) | 8x2

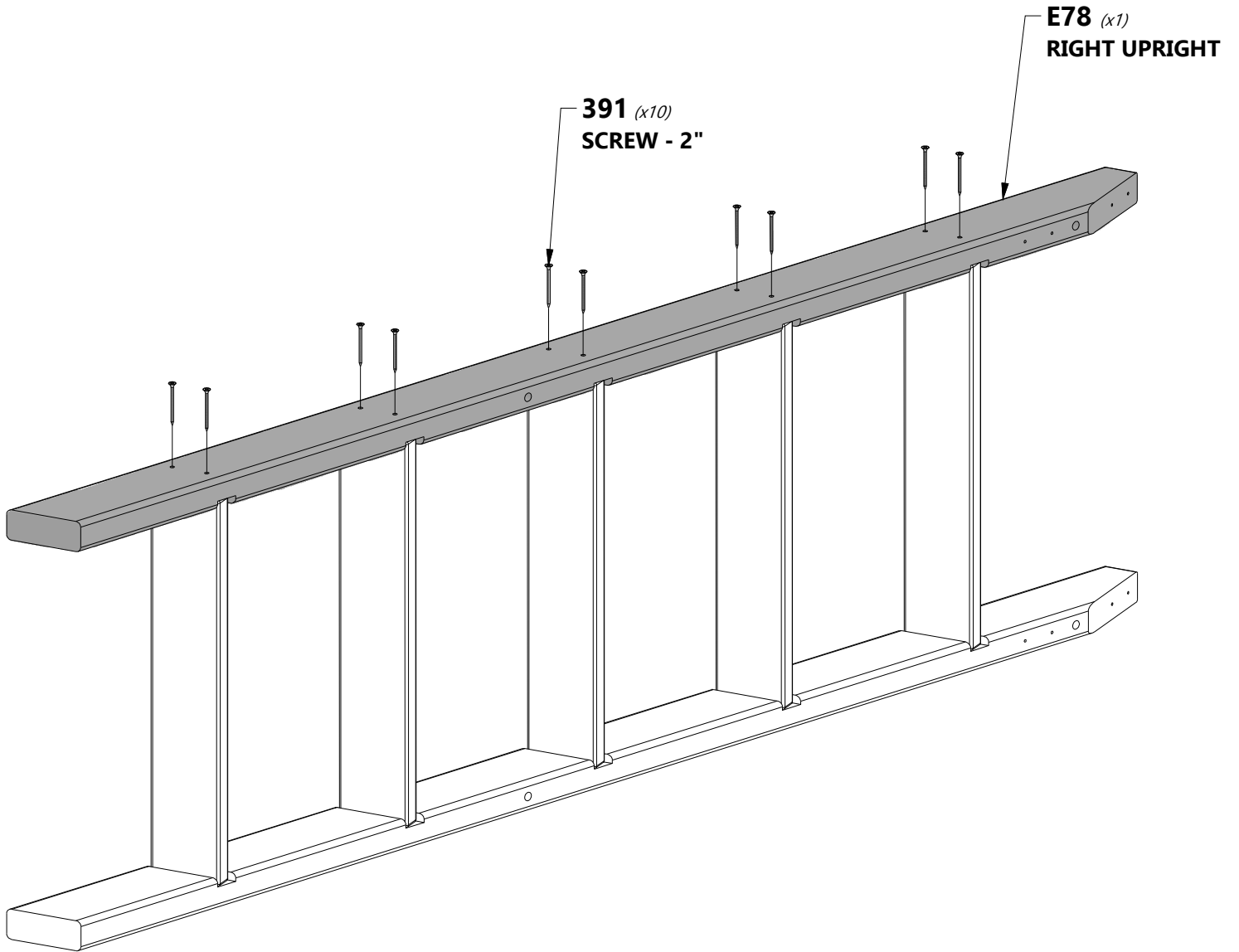

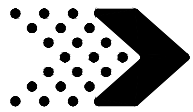

Phase 2

STEP 3



A100134
(x2) | **HAND GRIP GREEN 816 C/C**



H100503 | **BOLT WH BLK**
(x4) | **5/16x3-1/2**



H100379 | **T-NUT BLK**
(x4) | **5/16**



TIP:

WE RECOMMEND INSTALLING T-NUTS INTO BOARDS BEFORE ASSEMBLY.

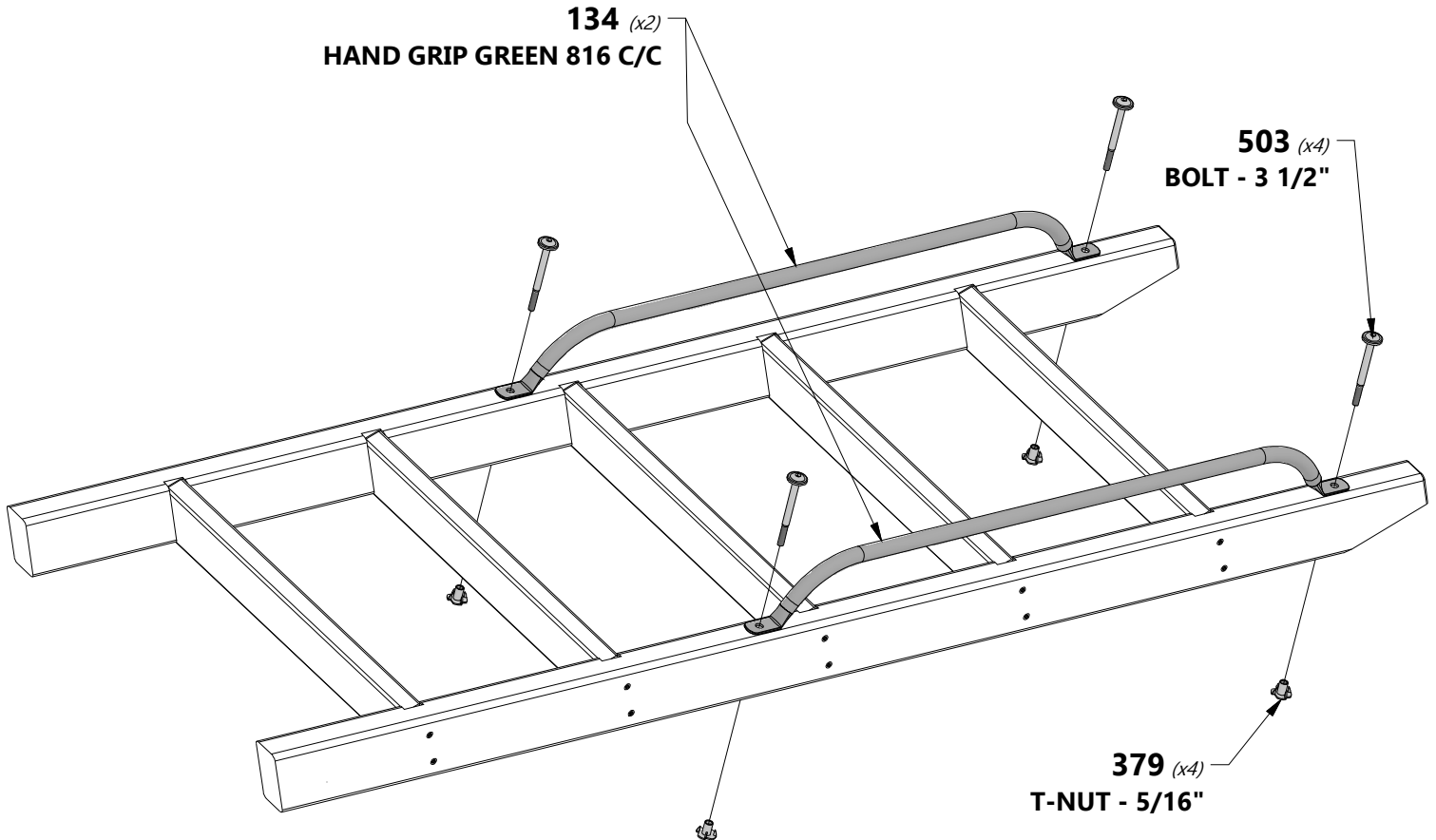

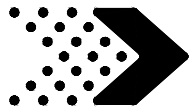

Phase 2

STEP 4



H110 | ATTACHMENT BOARD - W4L12839
(x1) | 1"x3 3/8"x20 1/8" (24x86x512)

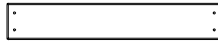

M73 | REAR SUPPORT - W4L11417
(x1) | 5/8"x3 3/8"x20 1/8" (16x86x512)



H100391 | SCREW PFH BLK
(x8) | 8x2

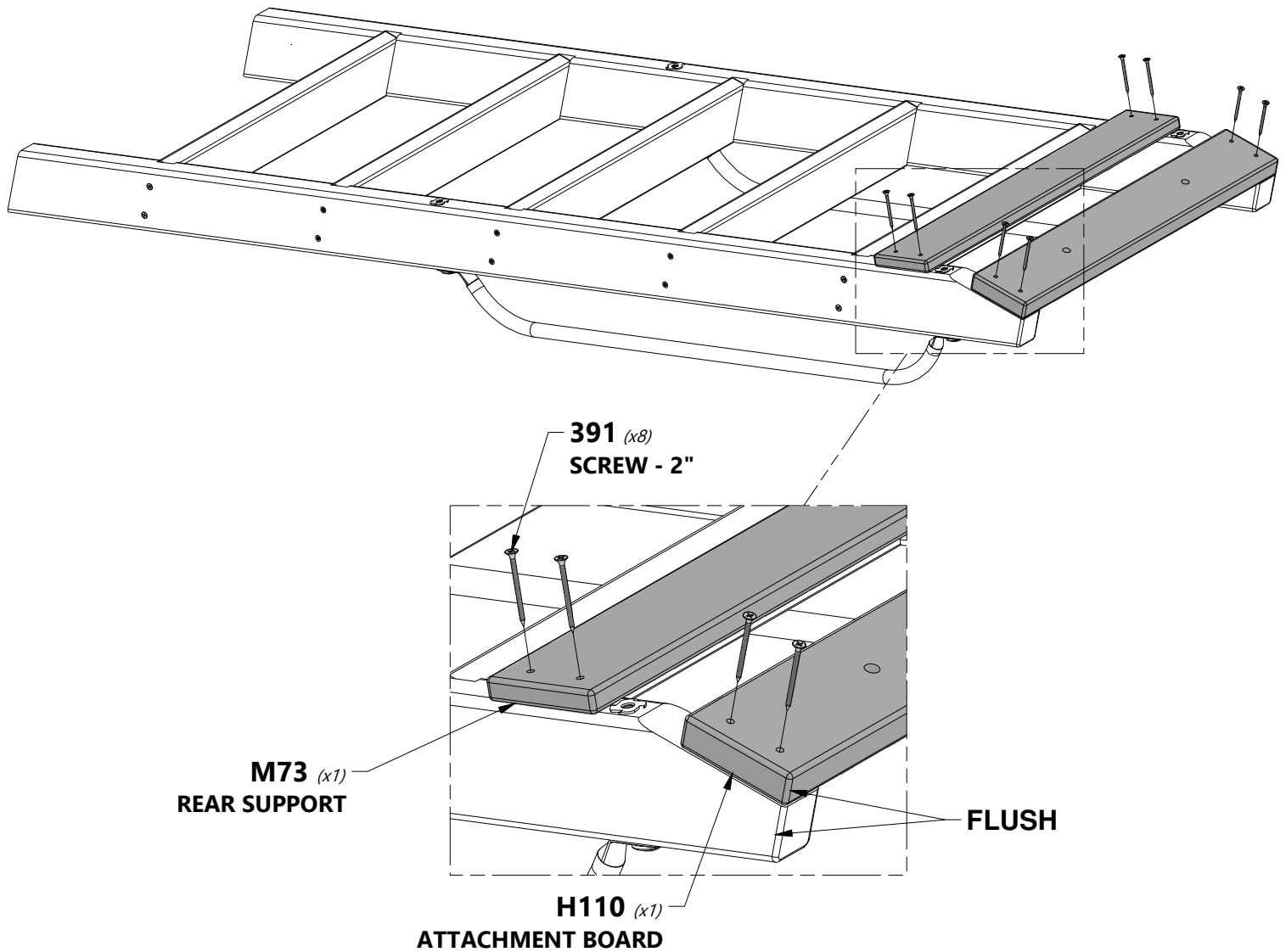

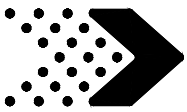

Phase 2

STEP 5

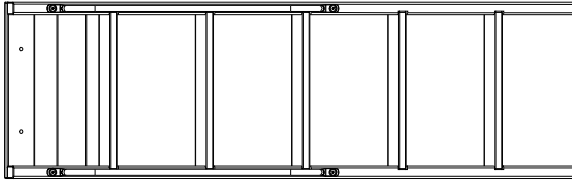

(x1) LADDER SUB ASSEMBLY
(FROM PREVIOUS STEP).



H100195 | BOLT WH BLK
(x2) | 5/16x2-3/4



H100198 | WASHER LOCK EXT BLK
(x2) | 8x19



H100379 | T-NUT BLK
(x2) | 5/16



TIP:

WE RECOMMEND INSTALLING T-NUTS INTO BOARDS BEFORE ASSEMBLY.

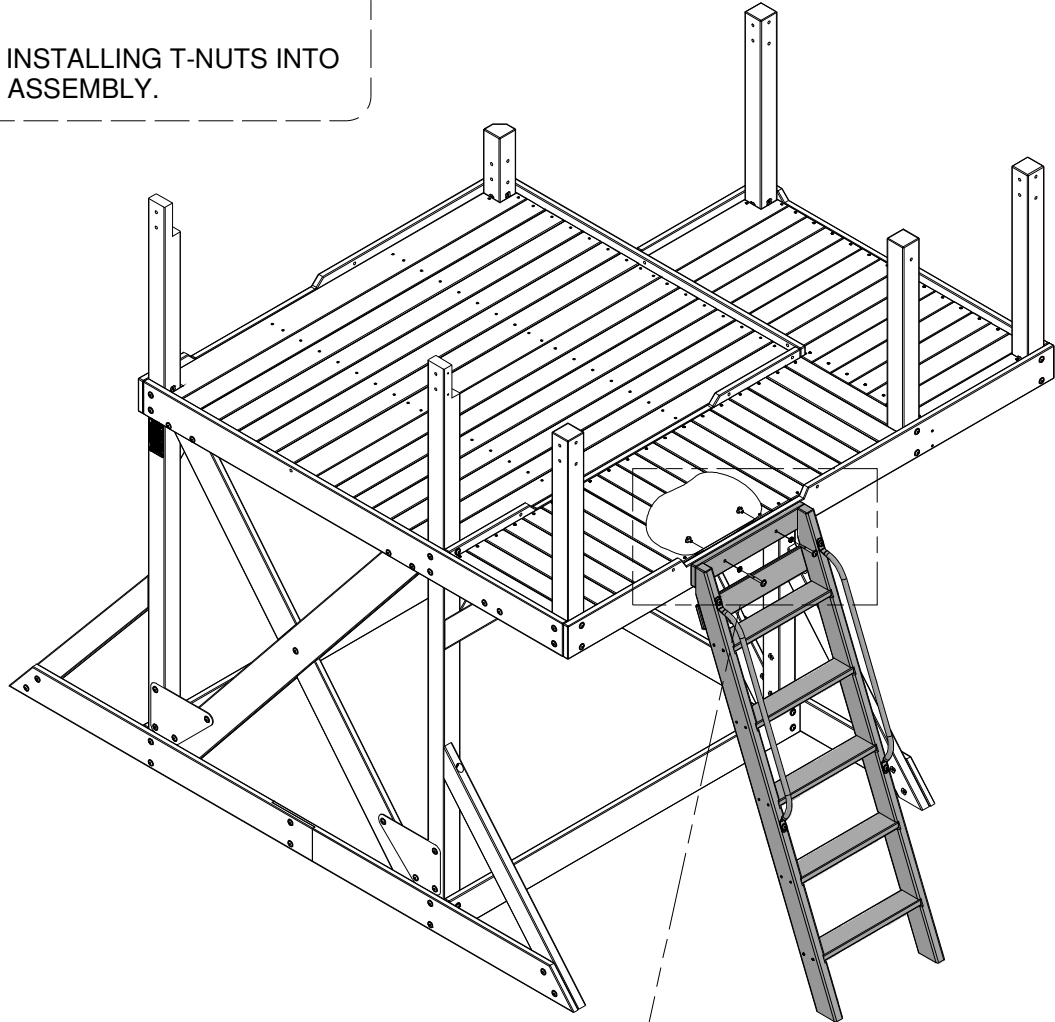

379 (x2)
T-NUT - 5/16"

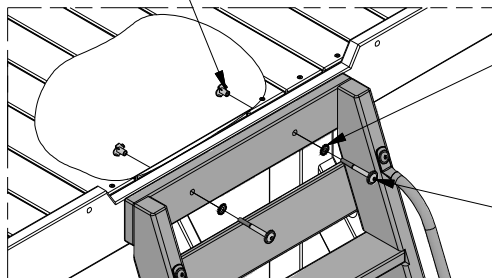

198 (x2)
WASHER - 8x19

195 (x2)
BOLT - 2-3/4

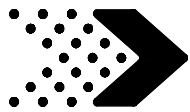

Phase 3

STEP 1



FRONT

G21 | WALL SUPPORT - W4L12815
(x1) | 1"x5 1/4"x77 3/8" (24x134x1964)



B15 | POST - W4L12810
(x2) | 3"x3"x29 3/8" (76x76x746)



H100415 | BOLT WH BLK
(x6) | 5/16x3 3/4



H100198 | WASHER LOCK EXT BLK
(x6) | 8x19



H100379 | T-NUT BLK
(x10) | 5/16



NOTE:

ASSEMBLE THE SUB ASSEMBLY FIRST.



TIP:

WE RECOMMEND INSTALLING T-NUTS INTO BOARDS BEFORE ASSEMBLY.

T-NUTS LOCATED ON THE INSIDE OF THE FRONT.

379 (x4)
T-NUT - 5/16"

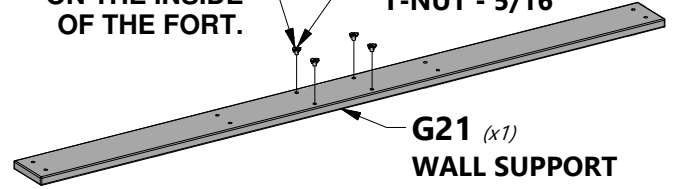

G21 (x1)
WALL SUPPORT
SUB ASSEMBLY

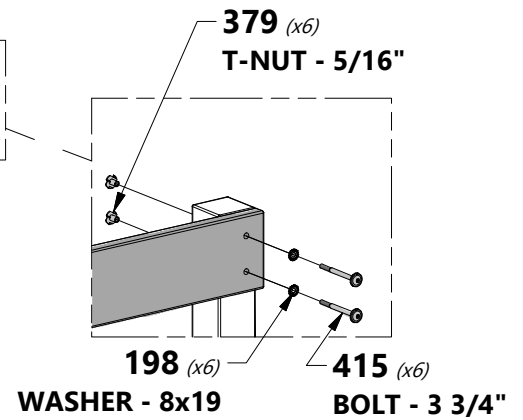
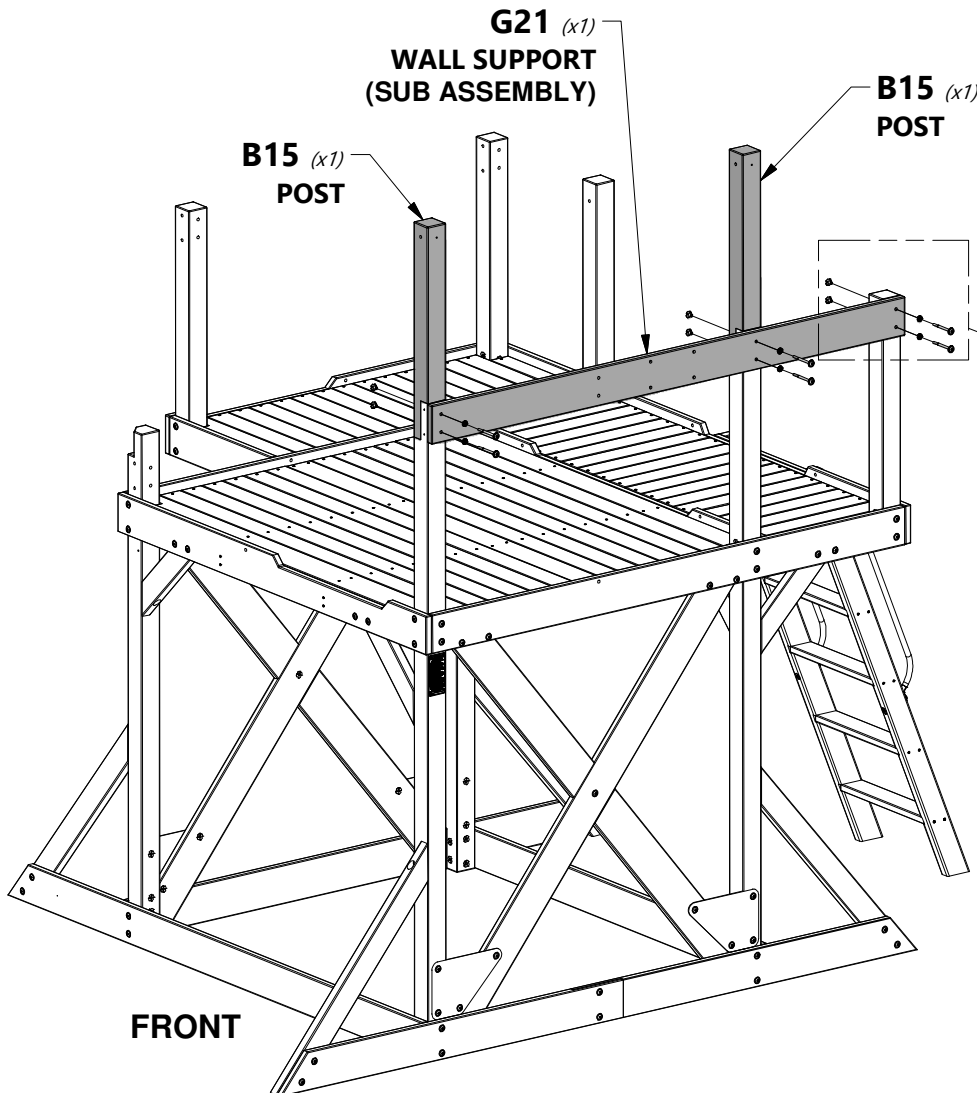



Phase 3

STEP 2

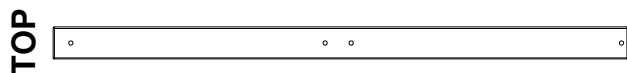

B14 | POST - W4L12826
(x1) | 3"x3"x53 7/8" (76x76x1370)



H100415 | BOLT WH BLK
(x3) | 5/16x3 3/4



H100198 | WASHER LOCK EXT BLK
(x3) | 8x19



H100379 | T-NUT BLK
(x3) | 5/16



TIP:

WE RECOMMEND INSTALLING T-NUTS INTO BOARDS BEFORE ASSEMBLY.

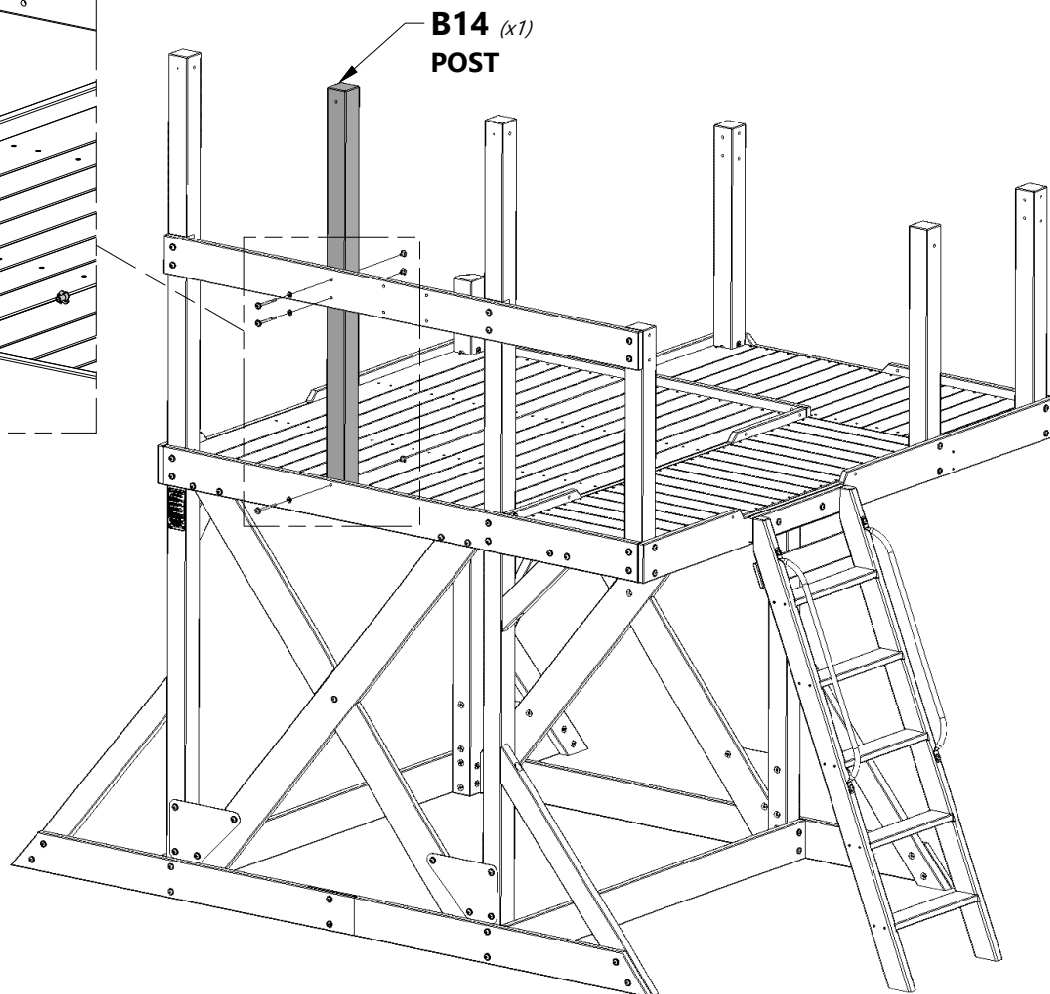
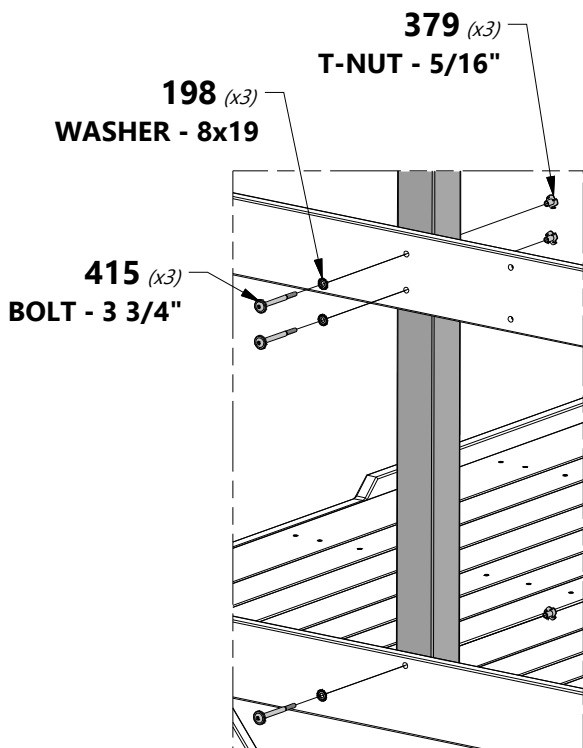

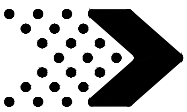

Phase 3

STEP 3

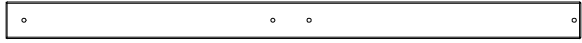

E2 | POST - W4L08522
(x2) | 3 3/8"x1 3/8"x53 7/8" (86x36x1370)



B8 | POST - W4L08475
(x1) | 3"x3"x53 7/8" (76x76x1370)



H100415 | BOLT WH BLK
(x1) | 5/16x3 3/4



H100458 | LAG SCREW WH BLK
(x1) | 5/16x2



H100379 | T-NUT BLK
(x3) | 5/16



H100198 | WASHER LOCK EXT BLK
(x4) | 8x19



H100205 | BOLT WH BLK
(x2) | 5/16x2-1/4



TIP:

WE RECOMMEND INSTALLING T-NUTS INTO BOARDS BEFORE ASSEMBLY.

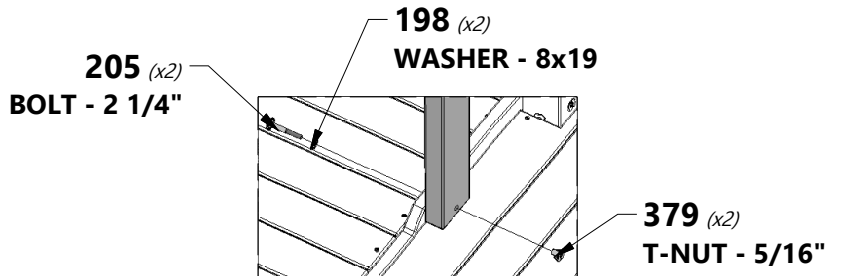

NOTE HOLE ORIENTATION FOR PROPER ASSEMBLY.

NOTE PILOT HOLE LOCATED IN THIS SURFACE ORIENTATE TO THE OUTSIDE OF THE FORT.

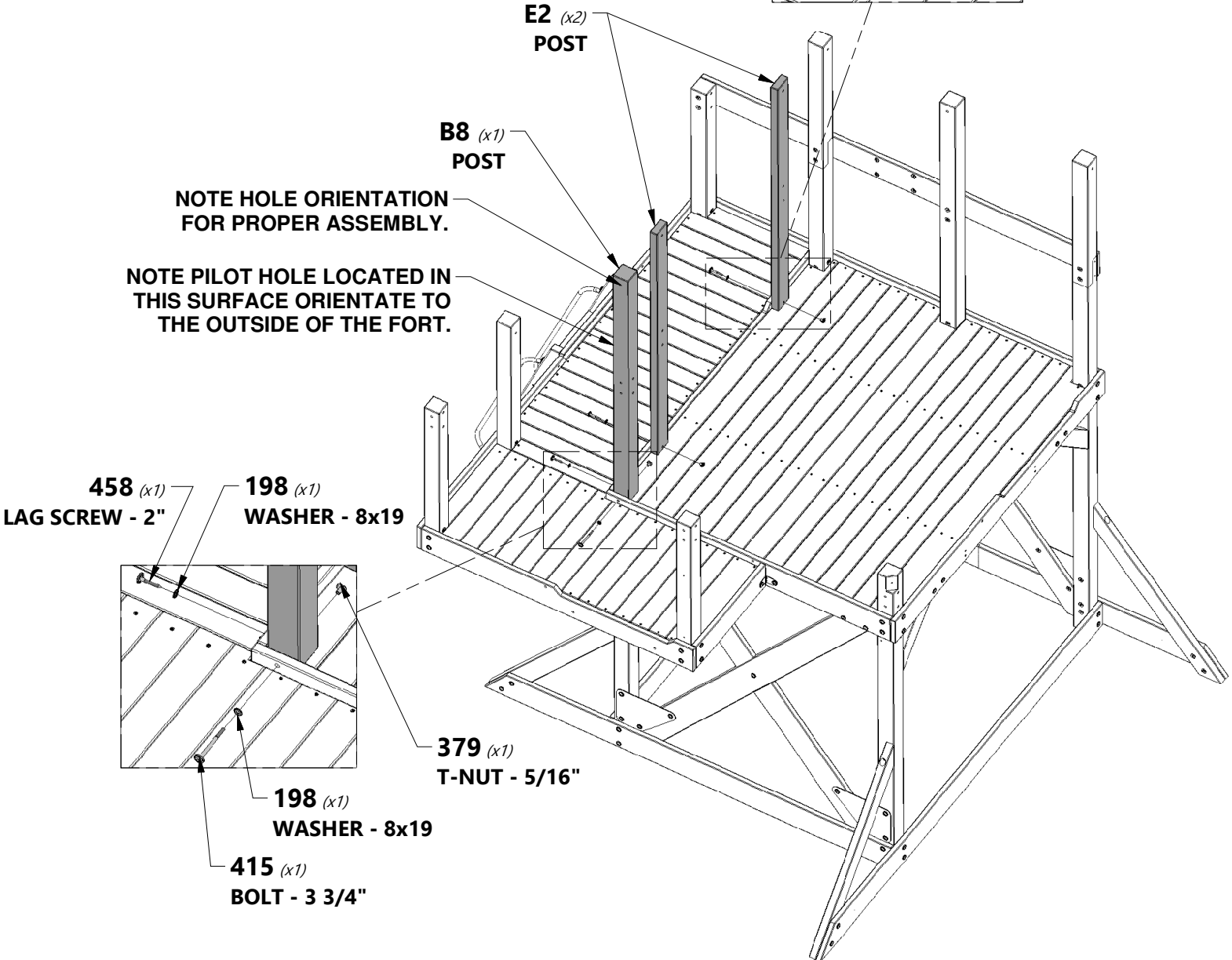

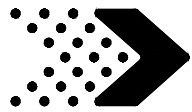

Phase 3

STEP 4



G16 | WALL SUPPORT - W4L08546
(x1) | 1"x5 1/4"x14 7/8" (24x134x378)

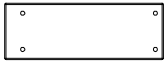

G17 | WALL SUPPORT - W4L12825
(x1) | 1"x5 1/4"x14 7/8" (24x134x378)



H100415 | BOLT WH BLK
(x2) | 5/16x3 3/4



H100458 | LAG SCREW WH BLK
(x2) | 5/16x2



H100379 | T-NUT BLK
(x6) | 5/16



H100198 | WASHER LOCK EXT BLK
(x8) | 8x19



H100205 | BOLT WH BLK
(x4) | 5/16x2-1/4



TIP:
WE RECOMMEND INSTALLING T-NUTS
INTO BOARDS BEFORE ASSEMBLY.

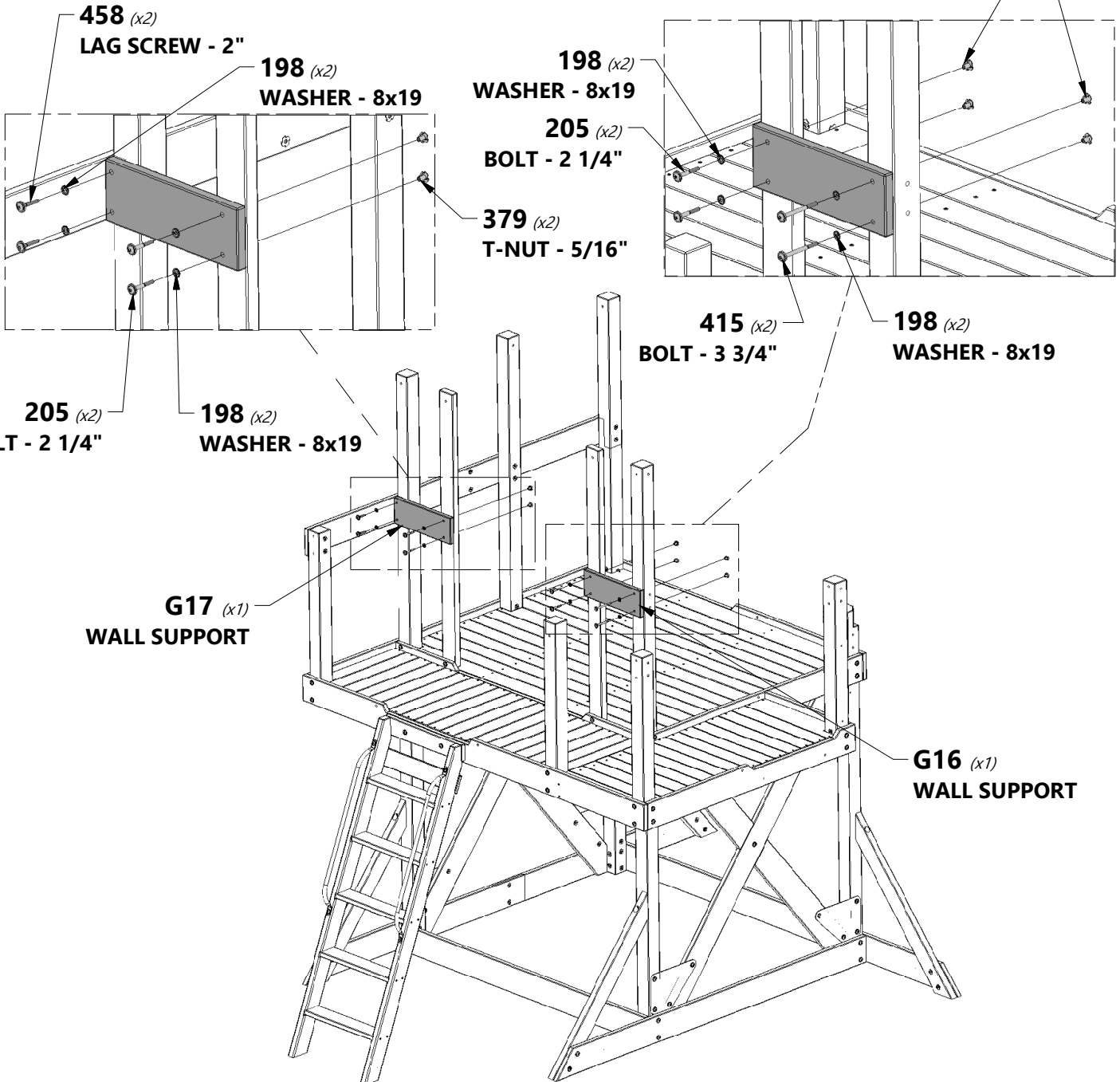

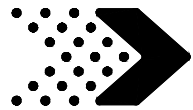

Phase 3

STEP 5



B9 | POST - W4L08476
(x1) | 3"x3"x53 7/8" (76x76x1370)



B16 | POST - W4L08553
(x1) | 3"x3"x53 7/8" (76x76x1370)



H100415 | BOLT WH BLK
(x2) | 5/16x3 3/4



H100198 | WASHER LOCK EXT BLK
(x2) | 8x19



H100379 | T-NUT BLK
(x2) | 5/16



TIP:

WE RECOMMEND INSTALLING T-NUTS INTO BOARDS BEFORE ASSEMBLY.

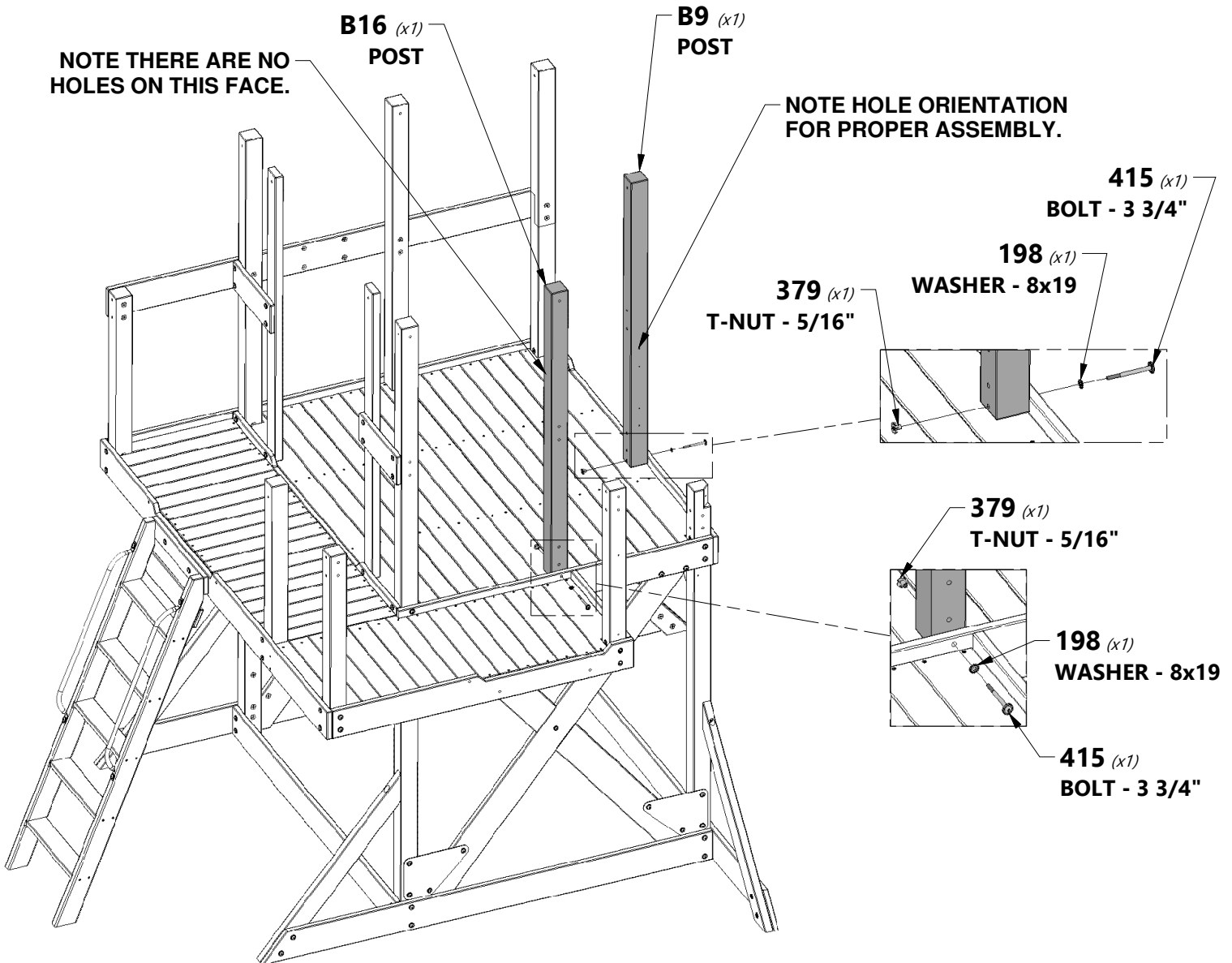

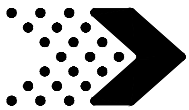

Phase 3

STEP 6



G13 | WALL SUPPORT - W4L08491
(x1) | 1"x5 1/4"x28 1/4" (24x134x716)

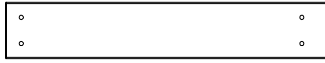

G15 | WALL SUPPORT - W4L08545
(x1) | 1"x5 1/4"x30 1/4" (24x134x768)



H100415 | BOLT WH BLK
(x8) | 5/16x3 3/4



H100198 | WASHER LOCK EXT BLK
(x8) | 8x19



H100379 | T-NUT BLK
(x8) | 5/16



TIP:
WE RECOMMEND INSTALLING T-NUTS
INTO BOARDS BEFORE ASSEMBLY.

G15 (x1)
WALL SUPPORT

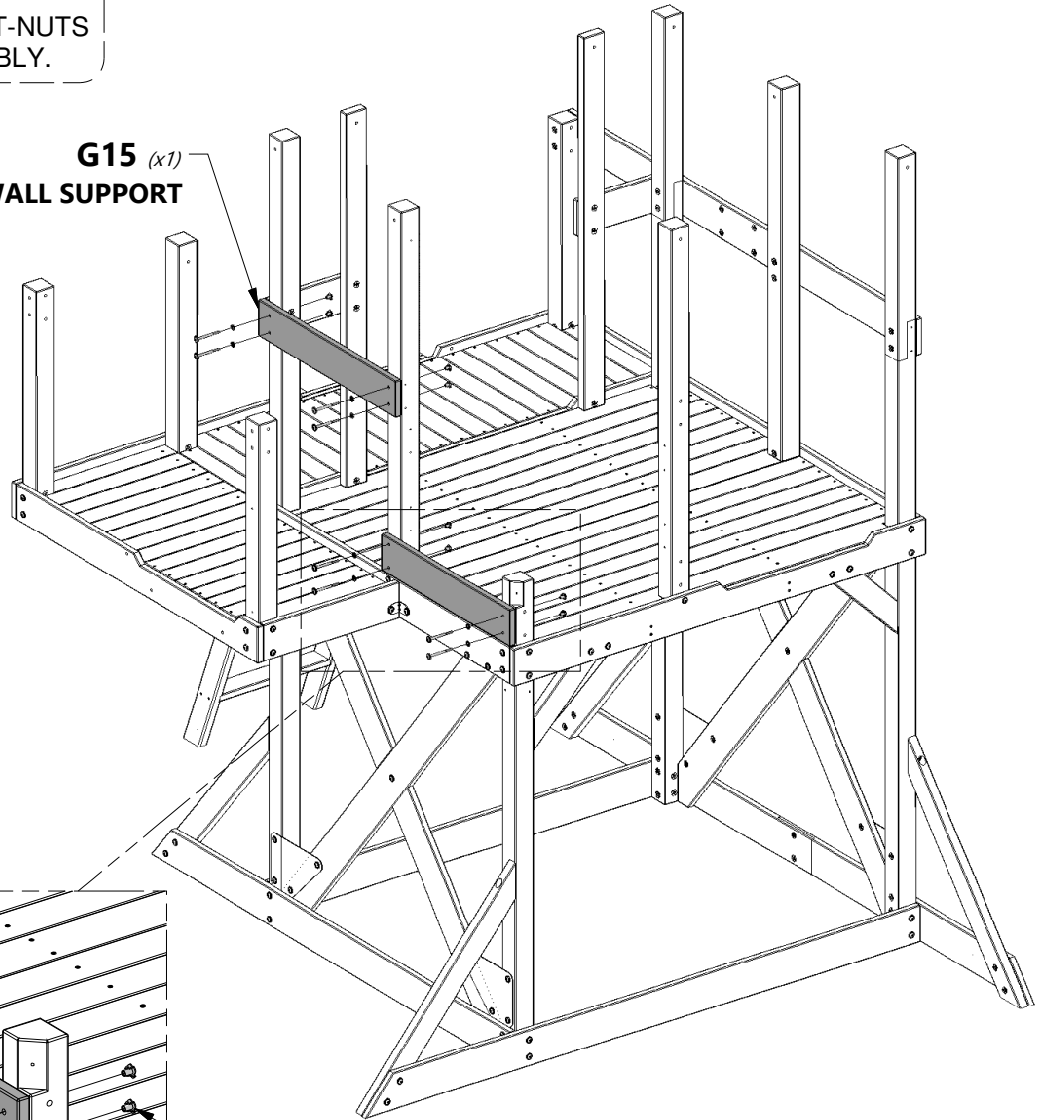

G13 (x1)
WALL SUPPORT

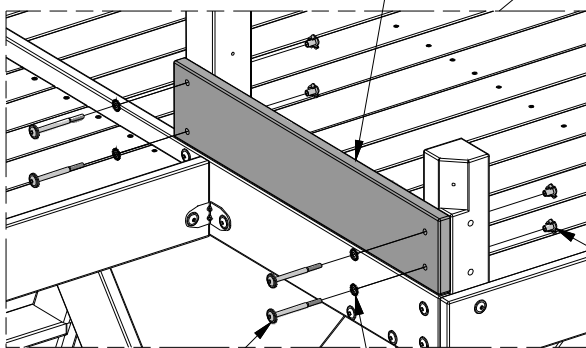

379 (x8)
T-NUT - 5/16"

415 (x8)
BOLT - 3 3/4"

198 (x8)
WASHER - 8x19

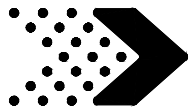

Phase 3

STEP 7



G12 | WALL SUPPORT - W4L08490
(x1) | 1"x5 1/4"x29 1/8" (24x134x741)



G30 | SLIDE ARCH BOARD - W4L12813
(x1) | 1"x5 1/4"x40 1/2" (24x134x1028)



H100415 | BOLT WH BLK
(x6) | 5/16x3 3/4



H100197 | LAG SCREW WH BLK
(x2) | 5/16x2-1/2



H100198 | WASHER LOCK EXT BLK
(x8) | 8x19



H100379 | T-NUT BLK
(x6) | 5/16

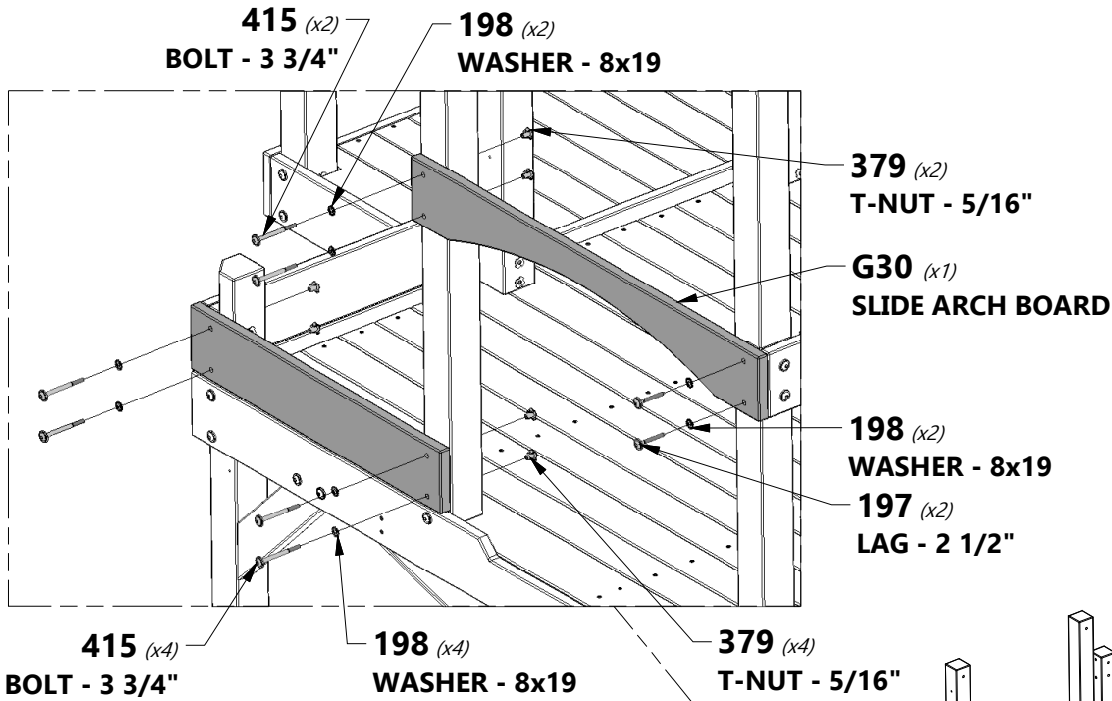

TIP:
WE RECOMMEND INSTALLING T-NUTS INTO BOARDS BEFORE ASSEMBLY.

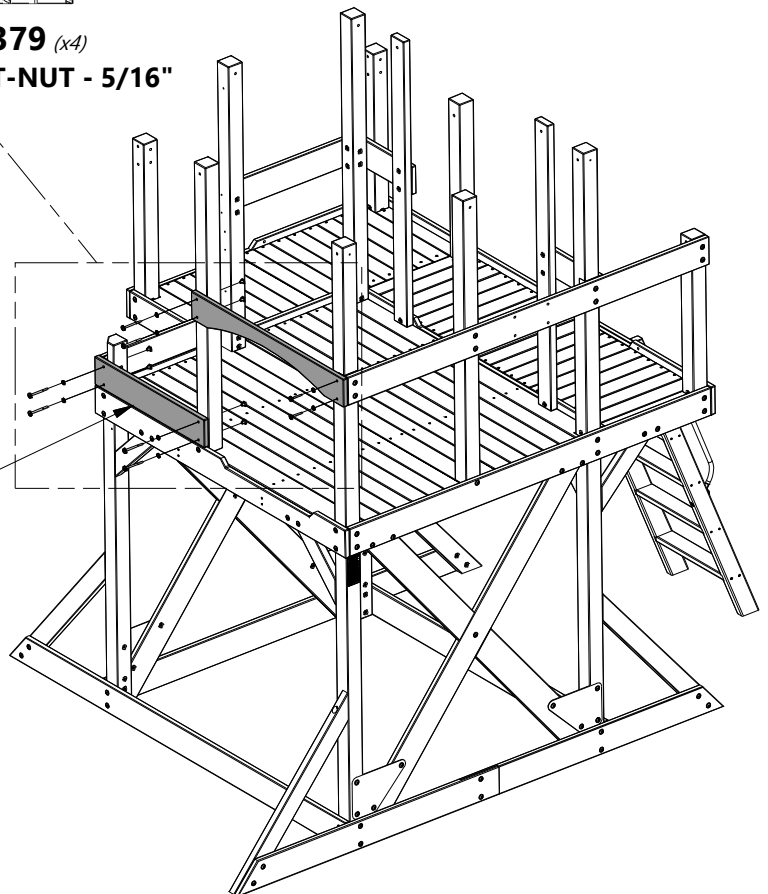

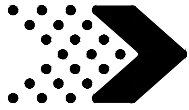

Phase 3

STEP 8



G24 | DECK BOARD - W4L12805
(x1) | 1"x5 1/4"x25 3/8" (24x134x645)



G25 | ENTRY BOARD - W4L12817
(x1) | 1"x5 1/4"x53 1/8" (24x134x1349)



H100415 | BOLT WH BLK
(x6) | 5/16x3 3/4



H100197 | LAG SCREW WH BLK
(x2) | 5/16x2-1/2



H100198 | WASHER LOCK EXT BLK
(x8) | 8x19



H100379 | T-NUT BLK
(x6) | 5/16

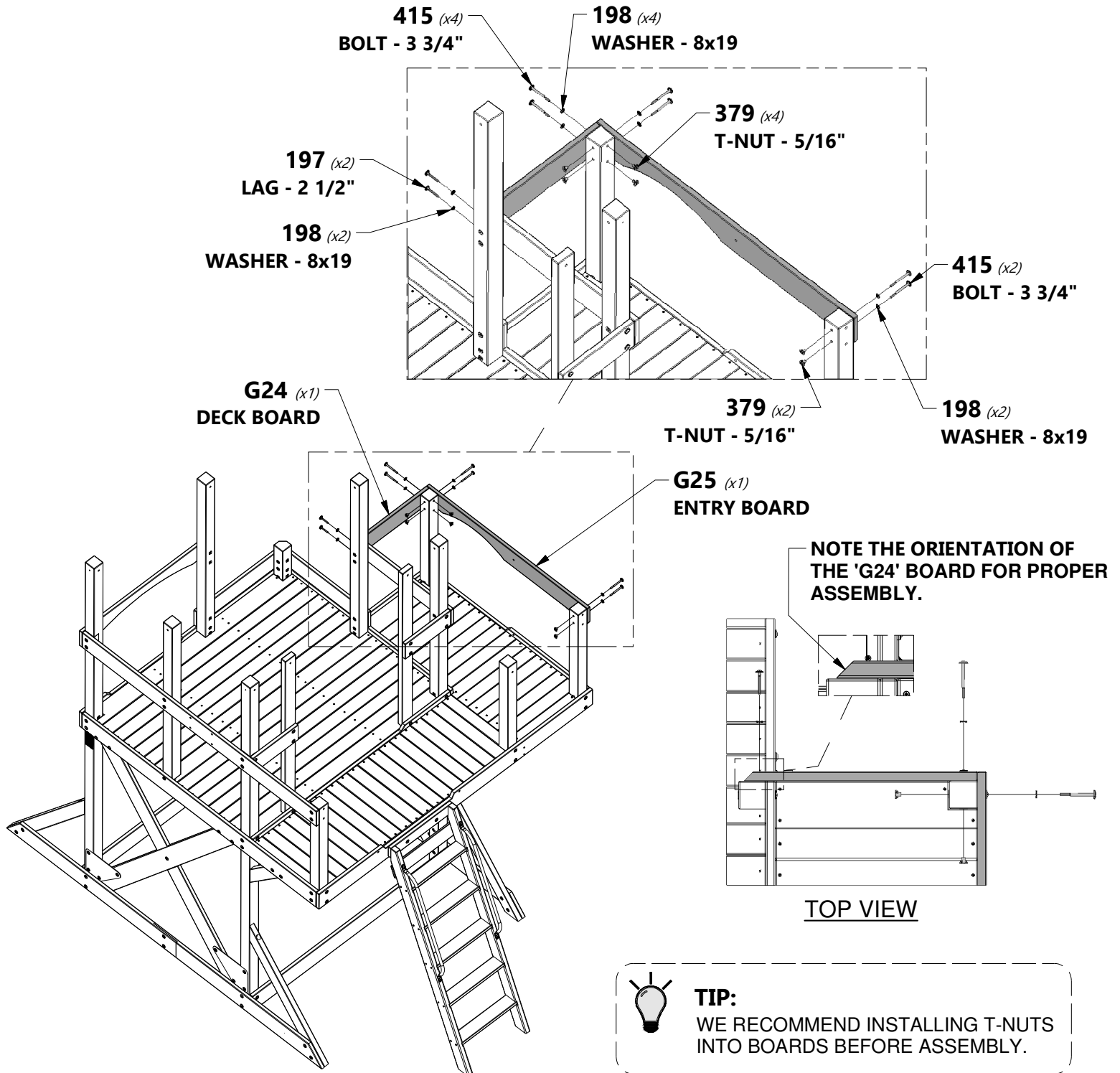

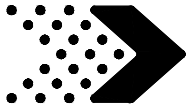

Phase 3

STEP 9

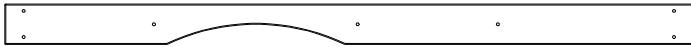

G28 | DECK BOARD - W4L12818
(x1) | 1"x5 1/4"x89 5/8" (24x134x2276)



H100415 | BOLT WH BLK
(x5) | 5/16x3 3/4



H100198 | WASHER LOCK EXT BLK
(x5) | 8x19



H100379 | T-NUT BLK
(x5) | 5/16



TIP:
WE RECOMMEND INSTALLING T-NUTS
INTO BOARDS BEFORE ASSEMBLY.

379 (x5)
T-NUT - 5/16"

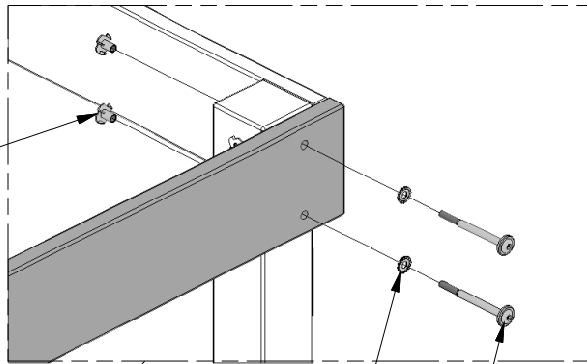

198 (x5)
WASHER - 8x19

415 (x5)
BOLT - 3 3/4"

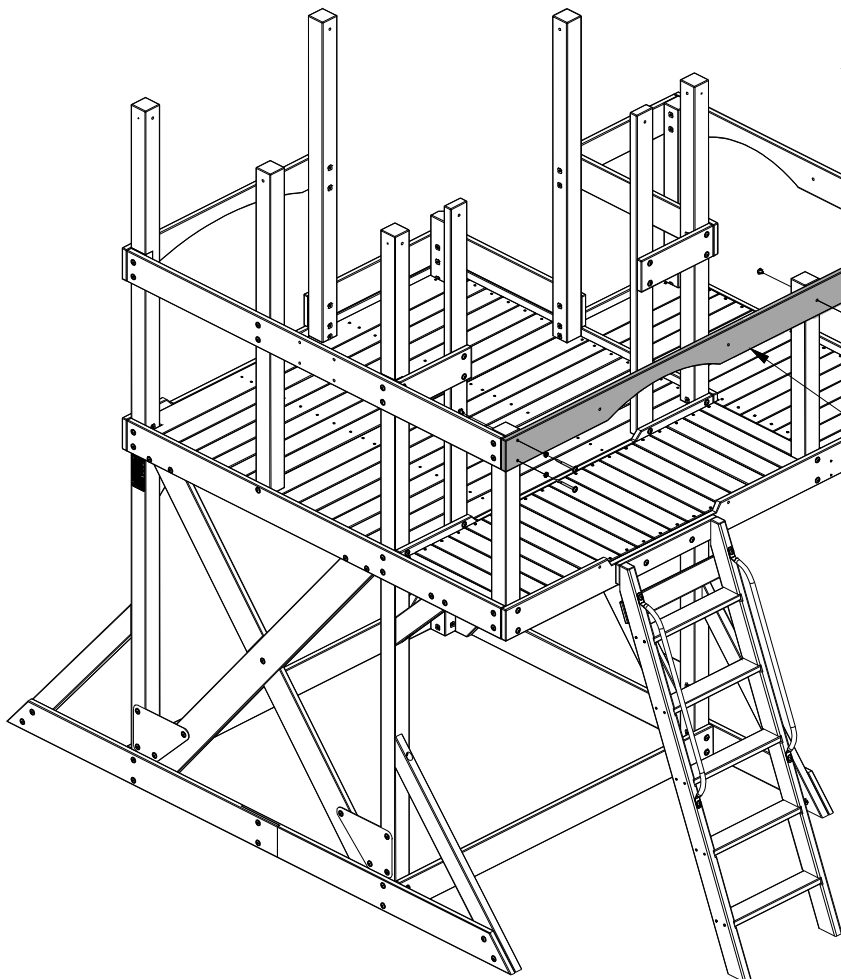

G28 (x1)
DECK BOARD

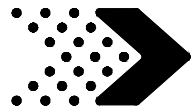

Phase 3

STEP 10



H11 | ROOF SUPPORT - W4L08518
(x1) | 1"x3 3/8"x76 3/4" (24x86x1949)



H100415 | BOLT WH BLK
(x1) | 5/16x3 3/4



H100458 | LAG SCREW WH BLK
(x2) | 5/16x2



H100198 | WASHER LOCK EXT BLK
(x3) | 8x19



H100379 | T-NUT BLK
(x1) | 5/16



TIP:
WE RECOMMEND INSTALLING T-NUTS
INTO BOARDS BEFORE ASSEMBLY.

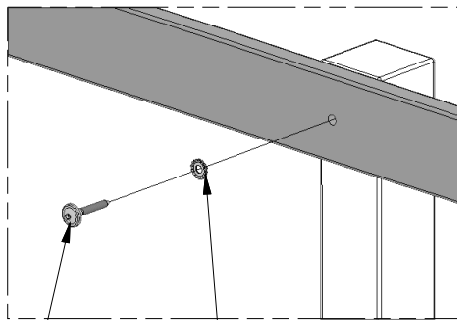

458 (x2)
LAG SCREW - 2"

198 (x2)
WASHER - 8x19

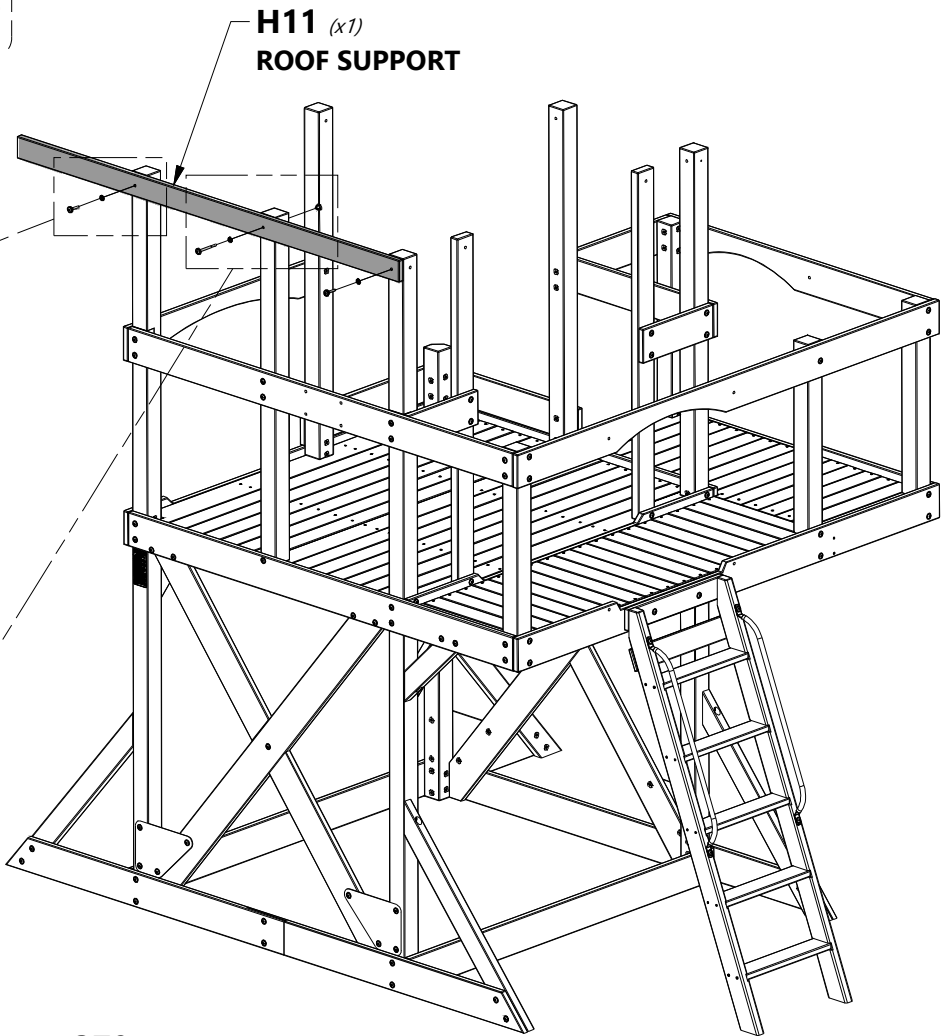

H11 (x1)
ROOF SUPPORT

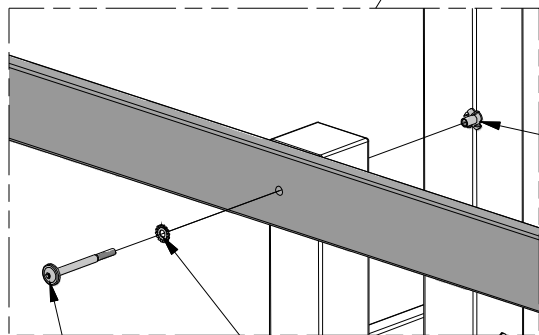

415 (x1)
BOLT - 3 3/4"

198 (x1)
WASHER - 8x19

379 (x1)
T-NUT - 5/16"

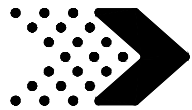

Phase 3

STEP 11

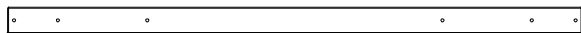

H13 | ROOF SUPPORT - W4L08520
(x1) | 1"x3 3/8"x74 3/4" (24x86x1900)



H100415 | BOLT WH BLK
(x1) | 5/16x3 3/4



H100379 | T-NUT BLK
(x3) | 5/16



H100458 | LAG SCREW WH BLK
(x1) | 5/16x2



H100198 | WASHER LOCK EXT BLK
(x4) | 8x19



H100205 | BOLT WH BLK
(x2) | 5/16x2-1/4



TIP:
WE RECOMMEND INSTALLING T-NUTS
INTO BOARDS BEFORE ASSEMBLY.

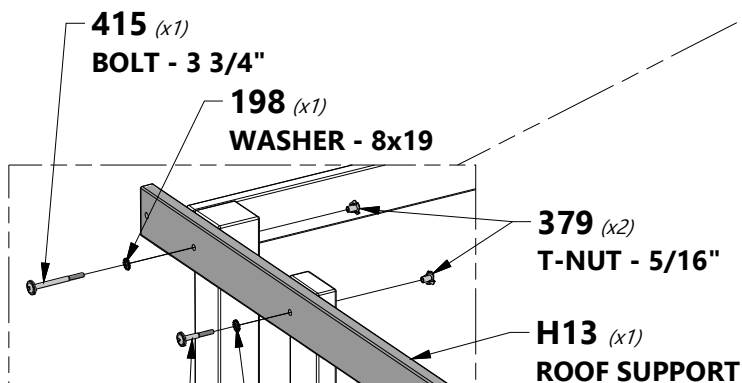

415 (x1)

BOLT - 3 3/4"

198 (x1)

WASHER - 8x19

379 (x2)

T-NUT - 5/16"

H13 (x1)

ROOF SUPPORT

205 (x1)

BOLT - 2 1/4"

198 (x1)

WASHER - 8x19

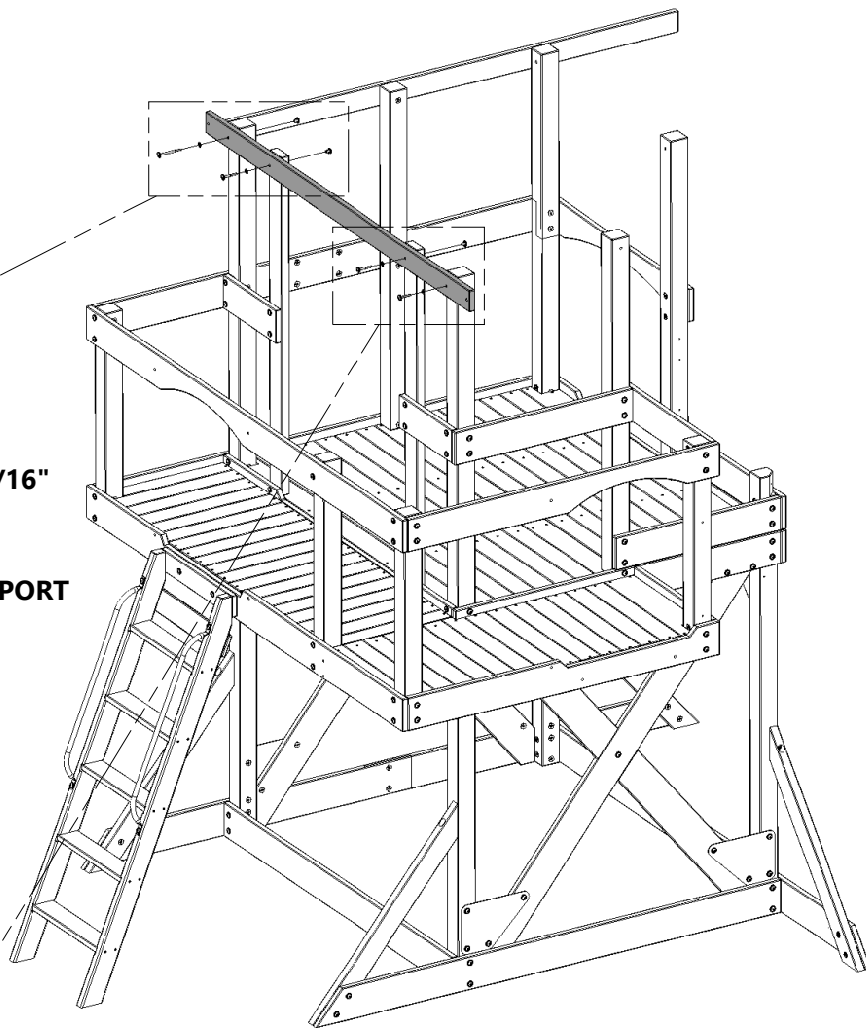

205 (x1)
BOLT - 2 1/4"

198 (x1)

WASHER - 8x19

379 (x1)

T-NUT - 5/16"

458 (x1)
LAG SCREW - 2"

198 (x1)

WASHER - 8x19

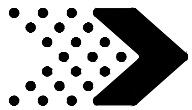

Phase 3

STEP 12

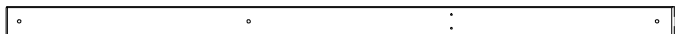

H10 | ROOF SUPPORT - W4L08513
(x1) | 1"x3 3/8"x76 3/4" (24x86x1949)



H100415 | BOLT WH BLK
(x2) | 5/16x3 3/4



H100198 | WASHER LOCK EXT BLK
(x2) | 8x19



H100379 | T-NUT BLK
(x2) | 5/16

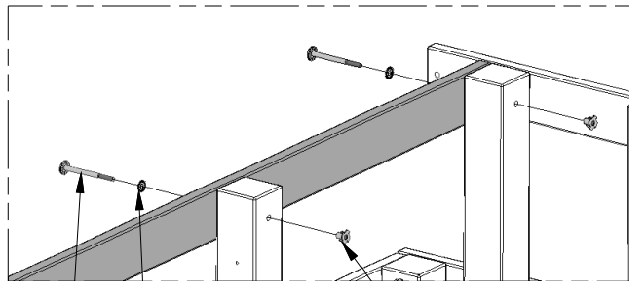

415 (x2)
BOLT - 3 3/4"

198 (x2)
WASHER - 8x19

379 (x2)
T-NUT - 5/16"



TIP:
WE RECOMMEND INSTALLING T-NUTS INTO BOARDS BEFORE ASSEMBLY.

H10 (x1)
ROOF SUPPORT

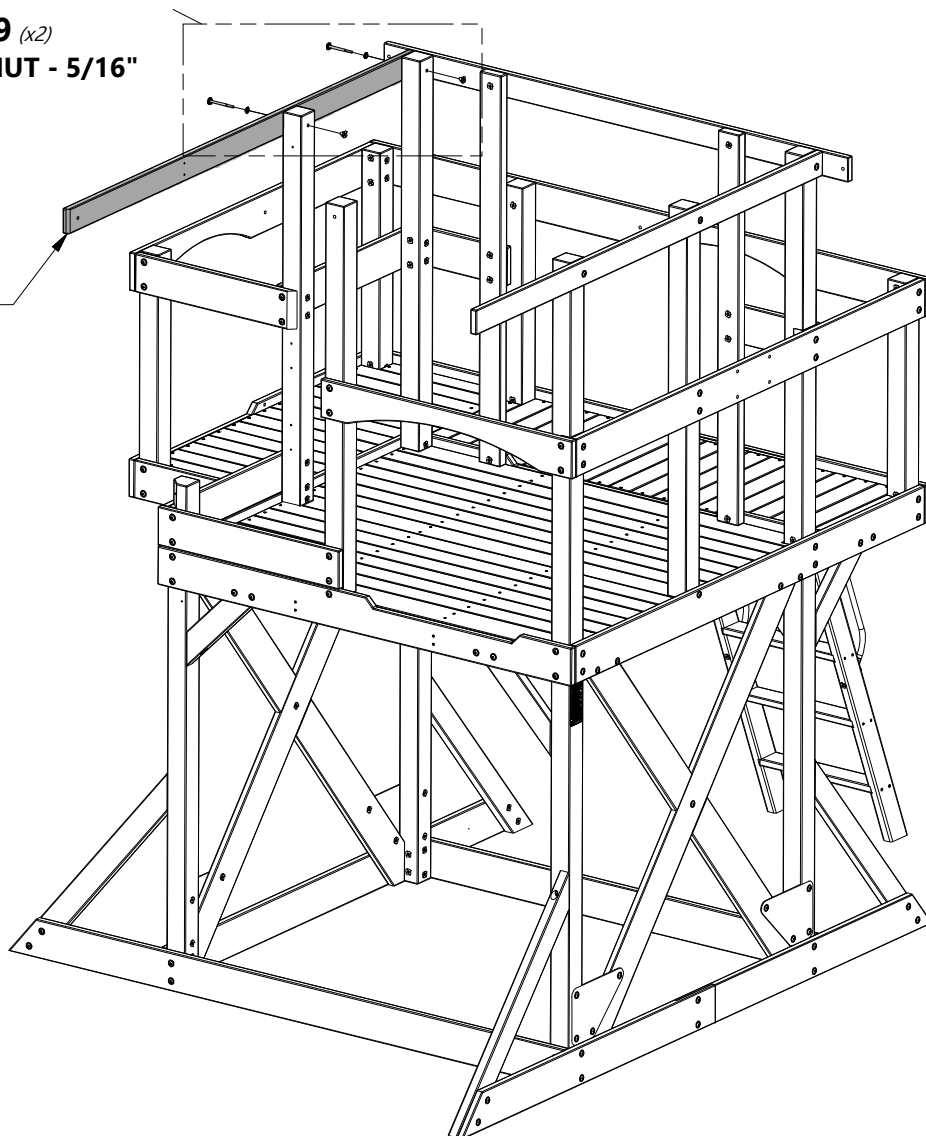

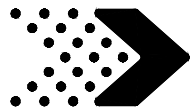

Phase 3

STEP 13

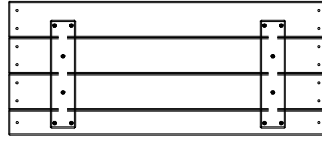
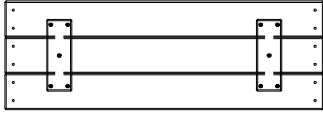

WP1 | RIGHT WALL PANEL - W2A02903
(x2) | 1 1/4"x10 3/16"x29 7/8" (32x258x759)

WP2 | RIGHT WALL PANEL - W2A02904
(x2) | 1 1/4"x10 3/16"x29 7/8" (32x258x759)



H100387 | SCREW PFH BLK
(x52) | 8x1-1/4

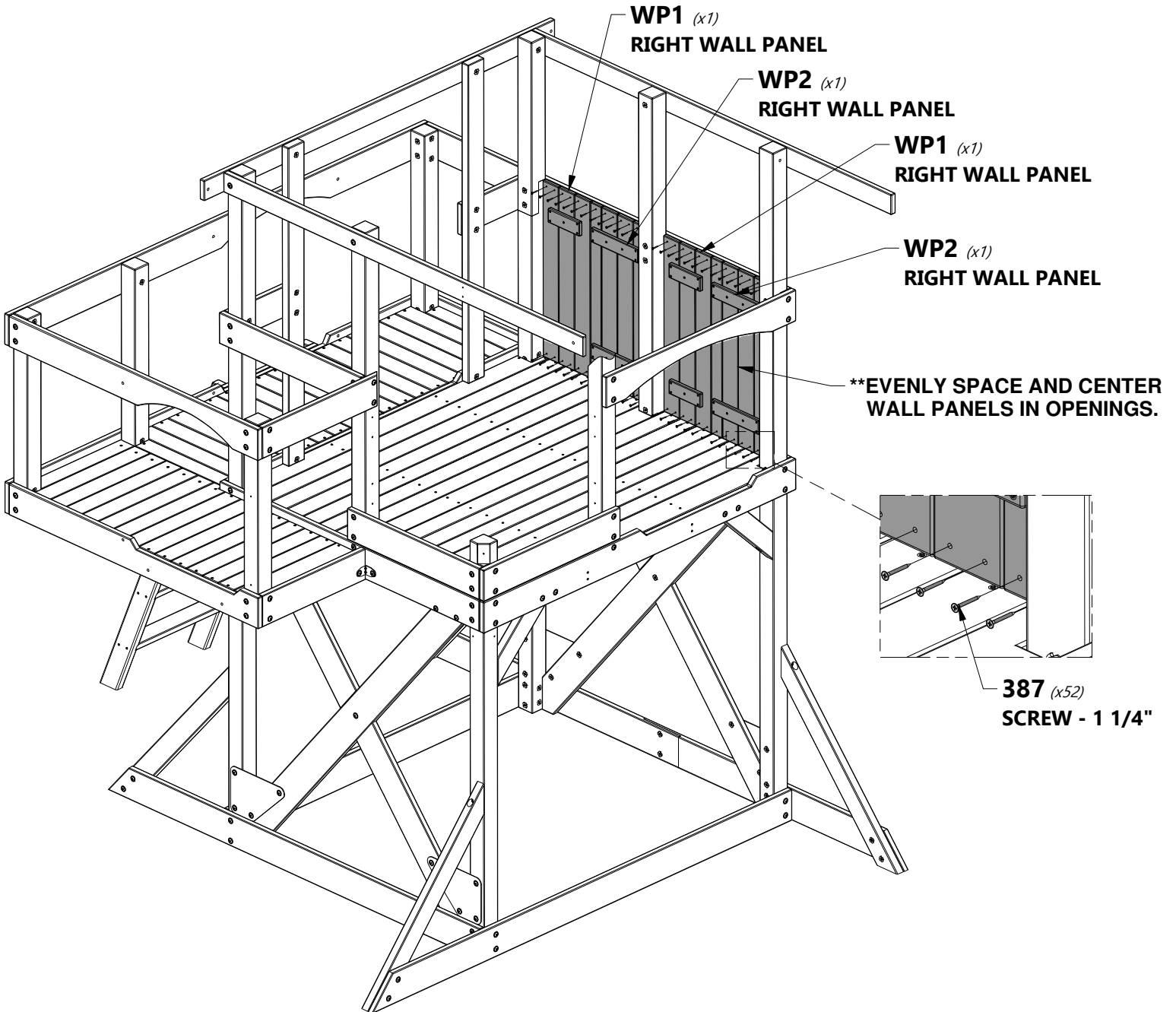

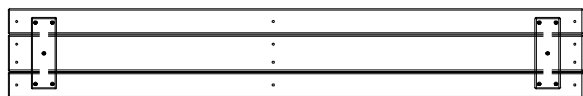
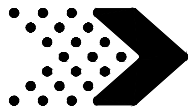

WP3 | REAR FORT WALL - W2A02905
(x2) | 1 1/4"x8 1/8"x53 15/16" (32x212x1370)



H100387 | SCREW PFH BLK
(x24) | 8x1-1/4

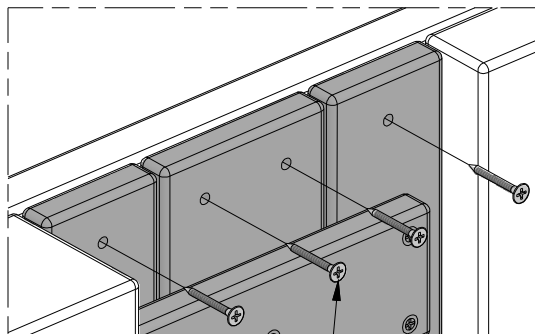

387 (x24)
SCREW - 1 1/4"

****CENTER WALL PANELS IN OPENINGS.**

WP3 (x2)
REAR FORT WALL

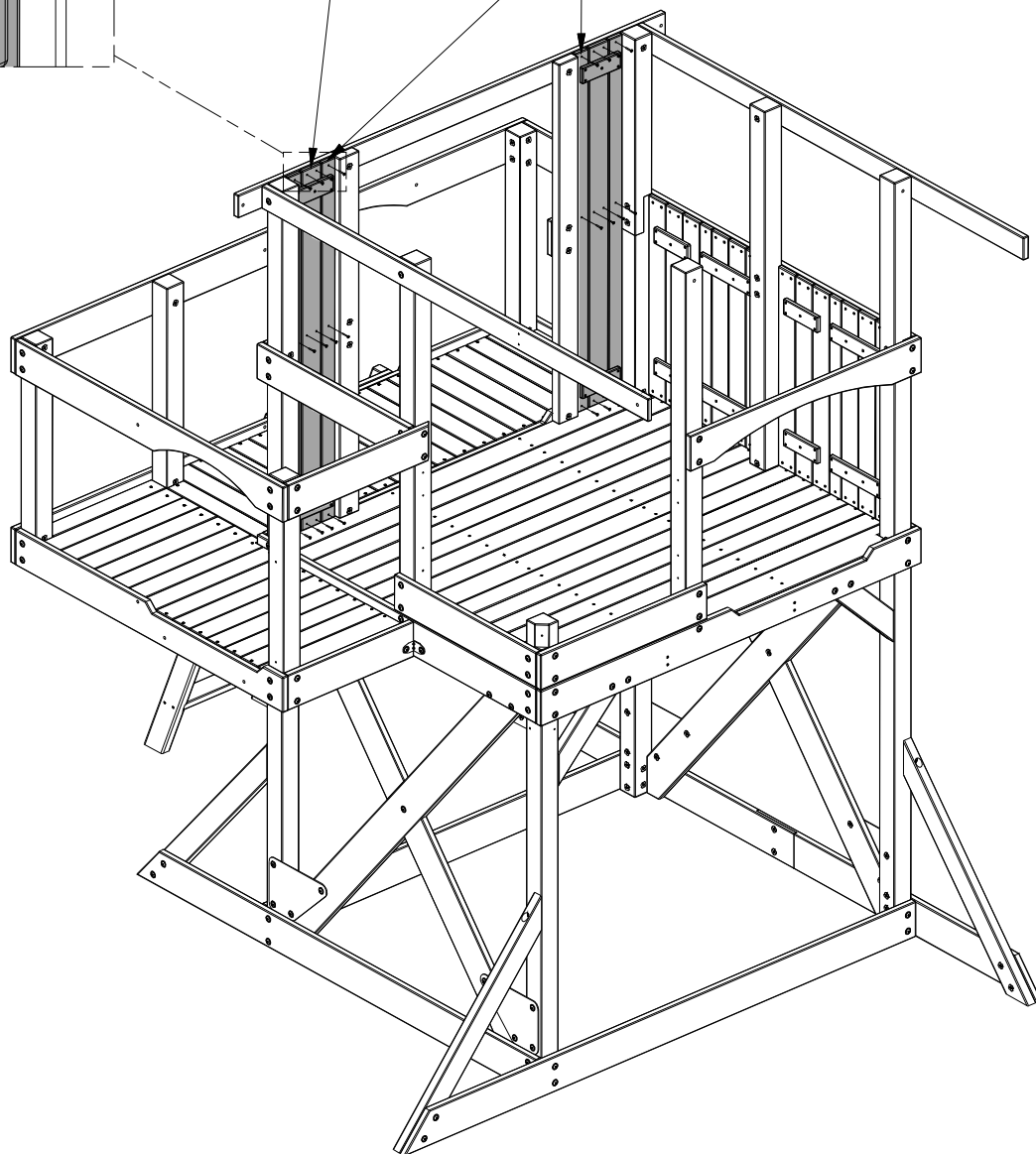

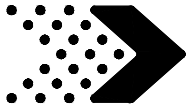

Phase 3

STEP 15

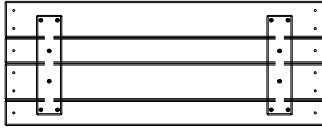

WP4 | WALL PANEL - W2A02906
(x2) | 1 1/4"x11 5/8"x29 7/8" (32x295x759)



H100387 | SCREW PFH BLK
(x24) | 8x1-1/4

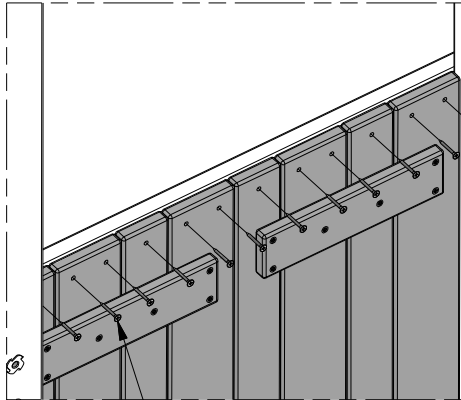

387 (x24)
SCREW - 1 1/4"

****EVENLY SPACE AND CENTER
WALL PANELS IN OPENINGS.**

WP4 (x2)
WALL PANEL

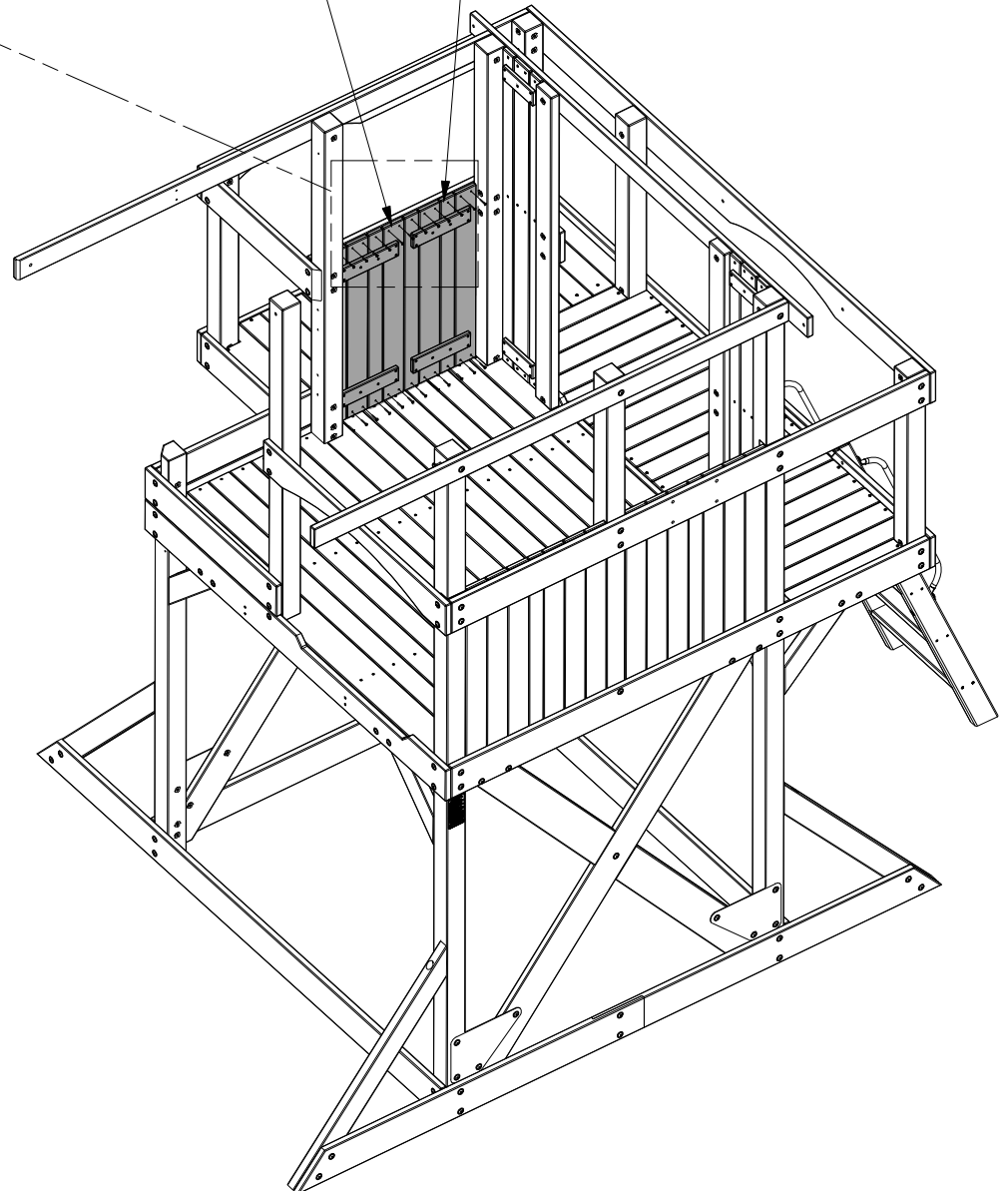

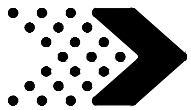

Phase 3

STEP 16



H1 | WALL PICKET - W4L12829
(x2) | 1"x3 3/8"x29 3/4" (24x86x756)



A100118 | HAND GRIP METAL GREEN 381 c/c
(x2)



H100378 | BOLT WH BLK
(x4) | 5/16x1 3/4



H100468 | BOLT WH BLK
(x4) | 5/16x1



H100198 | WASHER LOCK EXT BLK
(x4) | 8x19



H100379 | T-NUT BLK
(x8) | 5/16



NOTE:

ASSEMBLE THE SUB ASSEMBLY FIRST.



TIP:

WE RECOMMEND INSTALLING T-NUTS INTO BOARDS BEFORE ASSEMBLY.

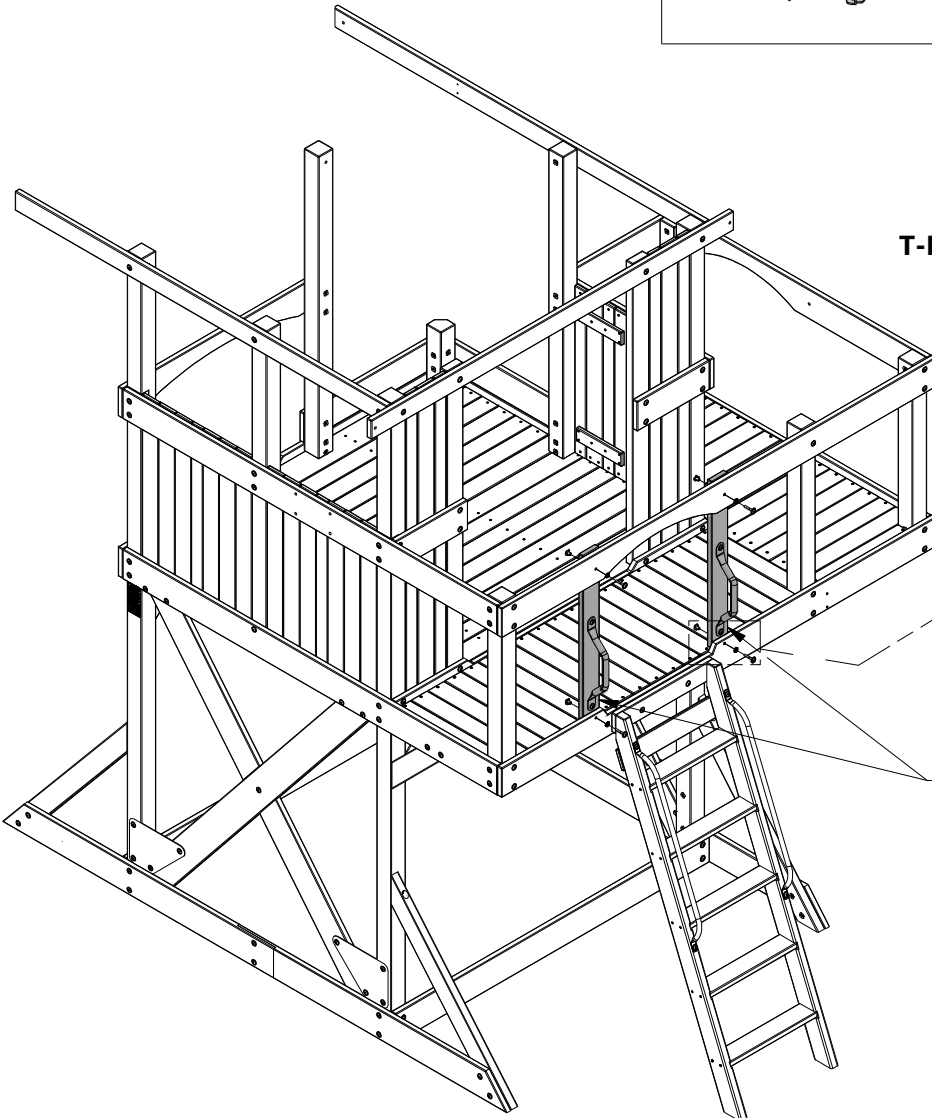
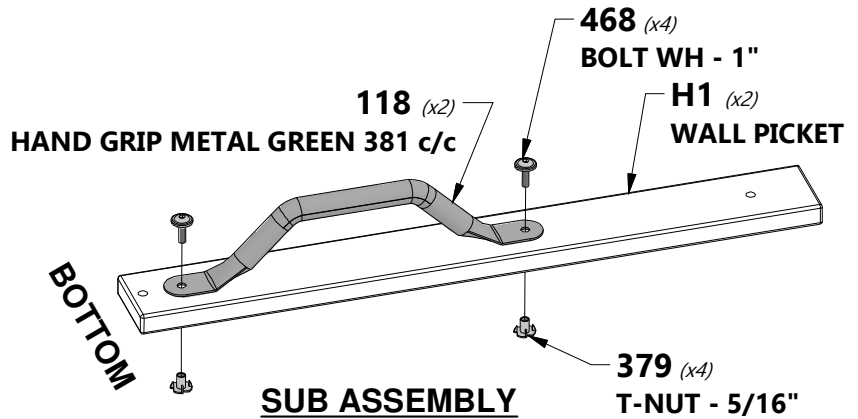

379 (x4)
T-NUT - 5/16"

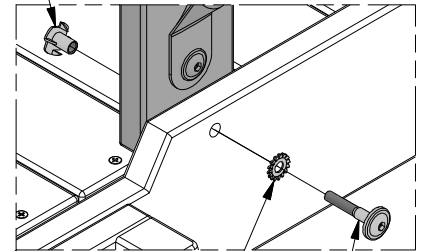

198 (x4)
WASHER - 8x19

378 (x4)
BOLT - 1 3/4"

**GRAB HANDLE
SUB ASSEMBLY**

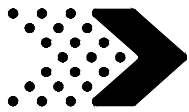

Phase 3

STEP 17



H1 | WALL PICKET - W4L12829
(x1) | 1"x3 3/8"x29 3/4" (24x86x756)



H100378 | BOLT WH BLK
(x2) | 5/16x1 3/4



H100198 | WASHER LOCK EXT BLK
(x2) | 8x19



H100379 | T-NUT BLK
(x2) | 5/16

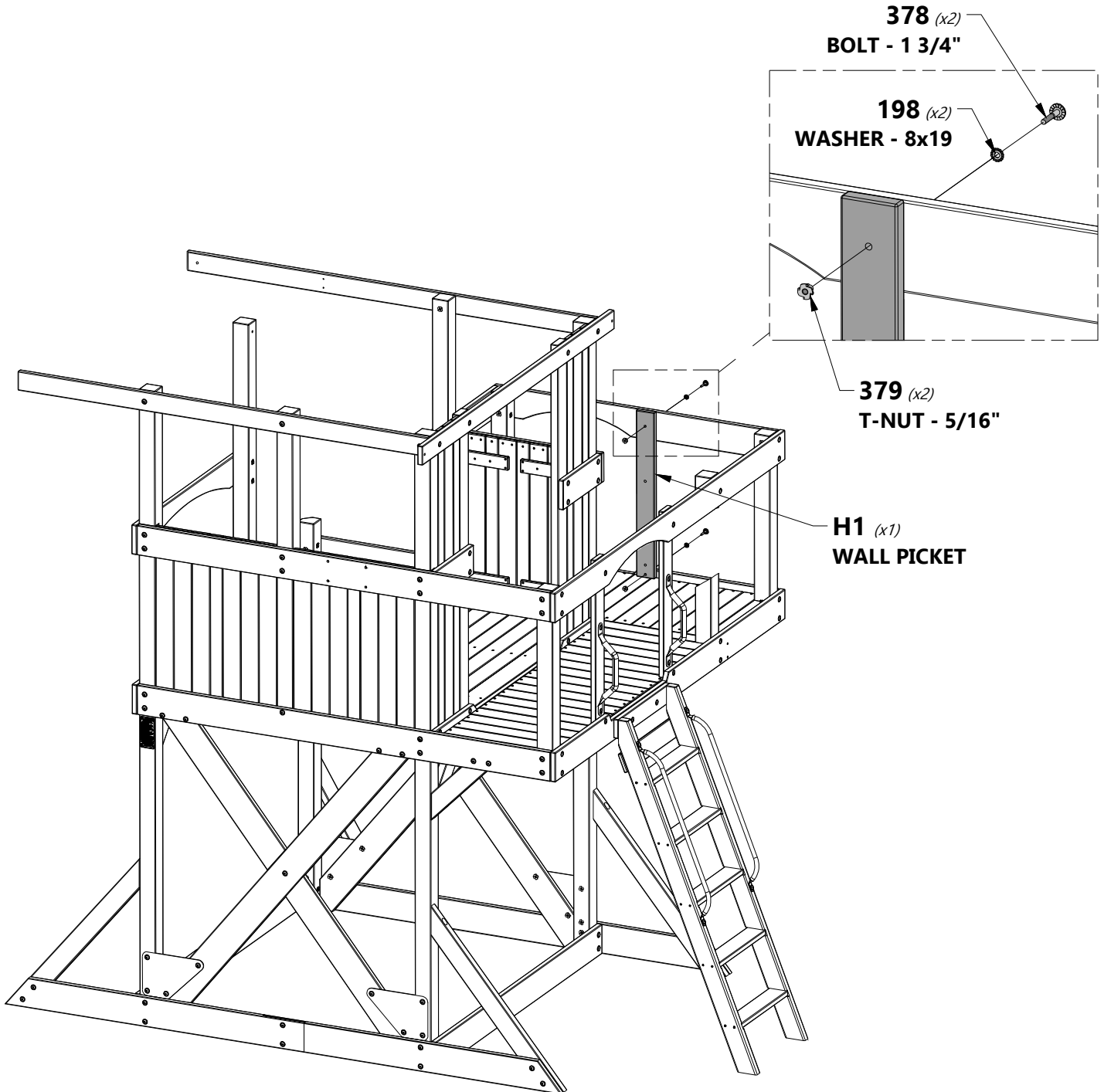



Phase 3

STEP 18



M23 | WALL PICKET - W4L08544
(x3) | 5/8"x3 3/8"x29 7/8" (16x86x759)



H100387 | SCREW PFH BLK
(x12) | 8x1-1/4

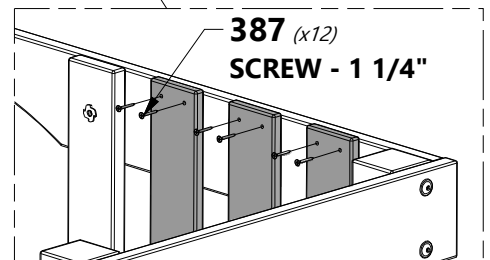
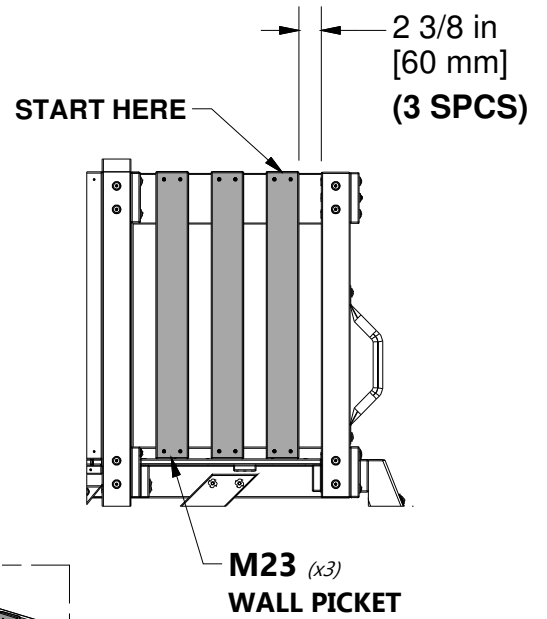
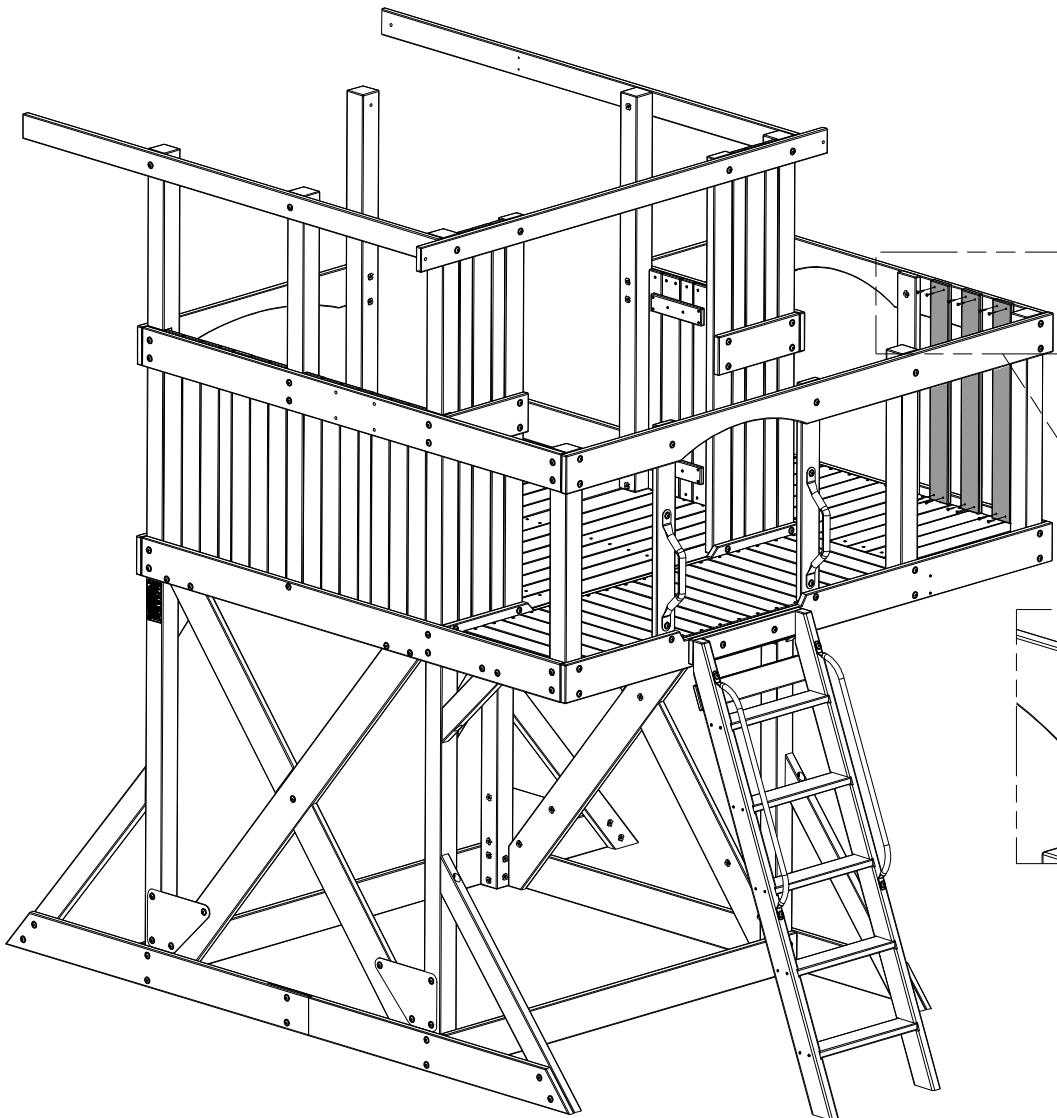

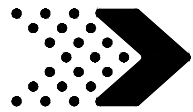

Phase 3

STEP 19



M23 | WALL PICKET - W4L08544
(x3) | 5/8"x3 3/8"x29 7/8" (16x86x759)



H100387 | SCREW PFH BLK
(x12) | 8x1-1/4

2 1/2 in
[62 mm]
(3 SPCS)

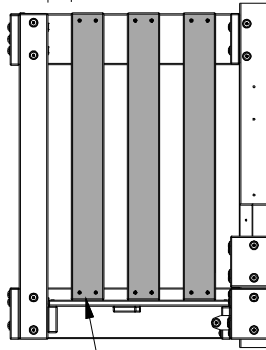

M23 (x3)
WALL PICKET

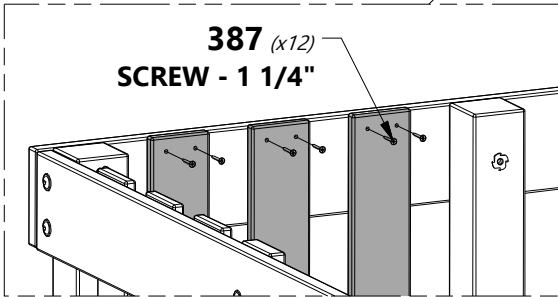
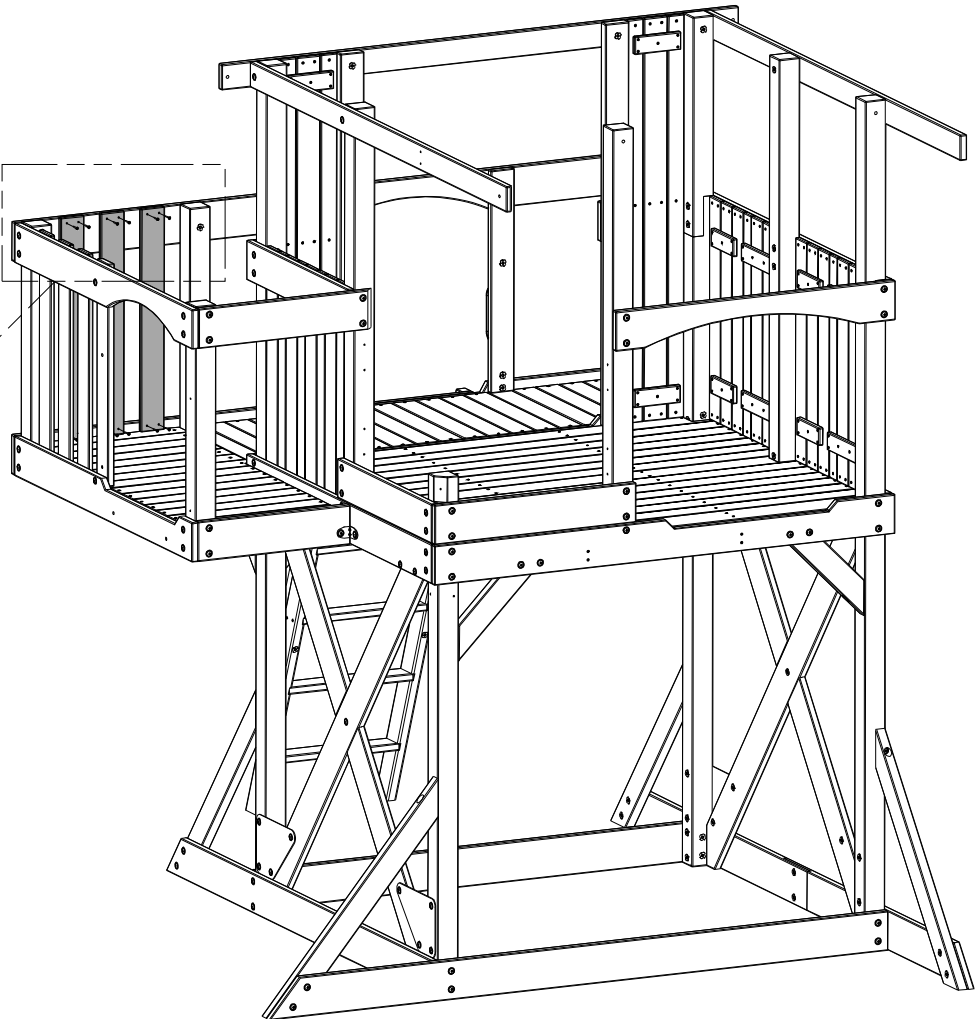

387 (x12)
SCREW - 1 1/4"

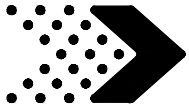

Phase 3

STEP 20



M23 | WALL PICKET - W4L08544
(x2) | 5/8"x3 3/8"x29 7/8" (16x86x759)



H100387 | SCREW PFH BLK
(x8) | 8x1-1/4

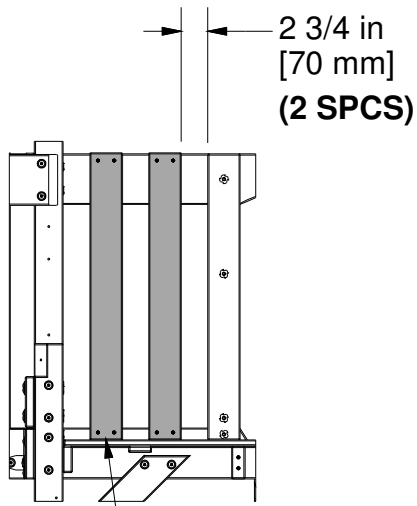

M23 (x2)
WALL PICKET

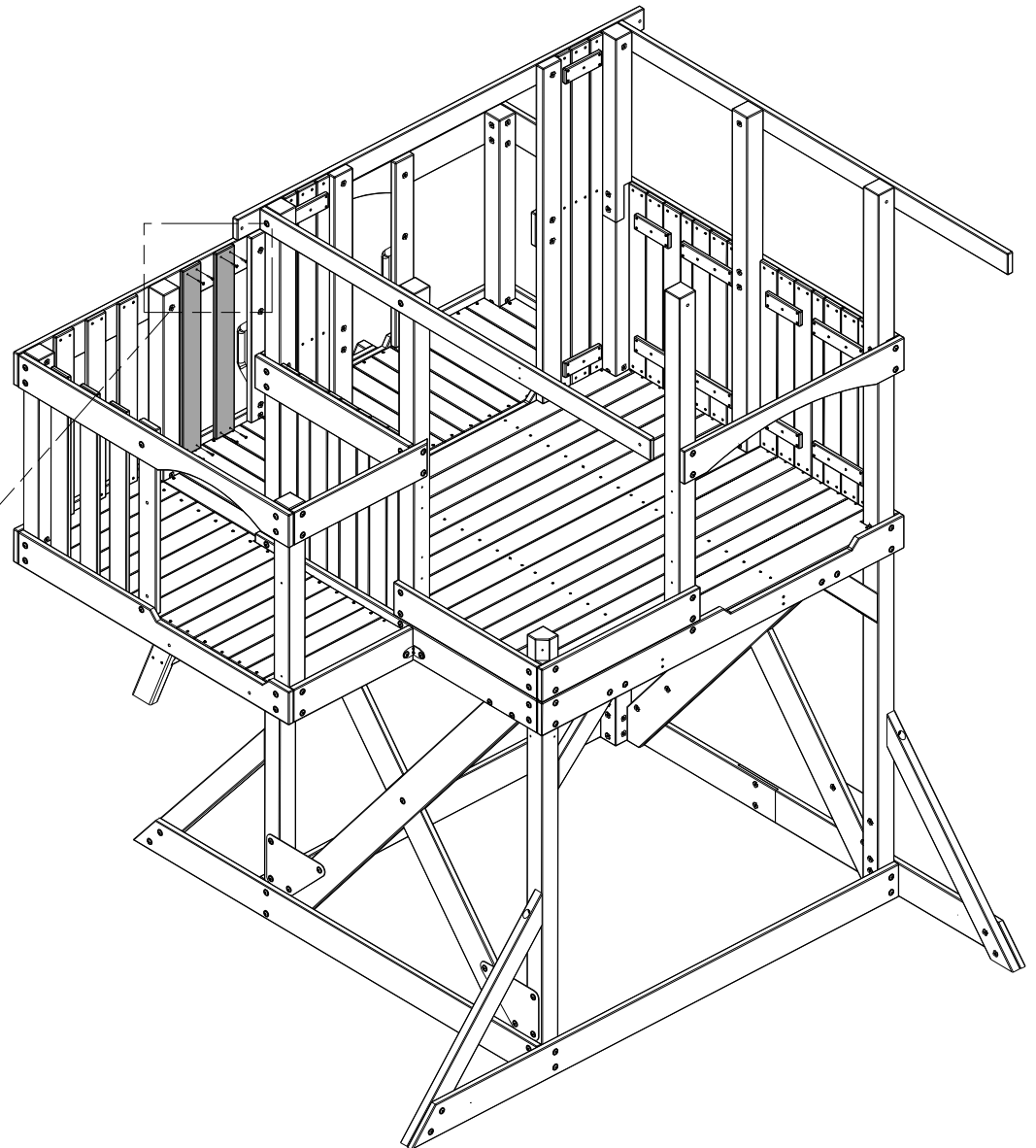

387 (x8)
SCREW - 1 1/4"

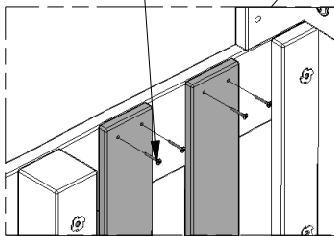

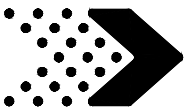

Phase 3

STEP 21



M23 | WALL PICKET - W4L08544
(x2) | 5/8"x3 3/8"x29 7/8" (16x86x759)



H100387 | SCREW PFH BLK
(x8) | 8x1-1/4

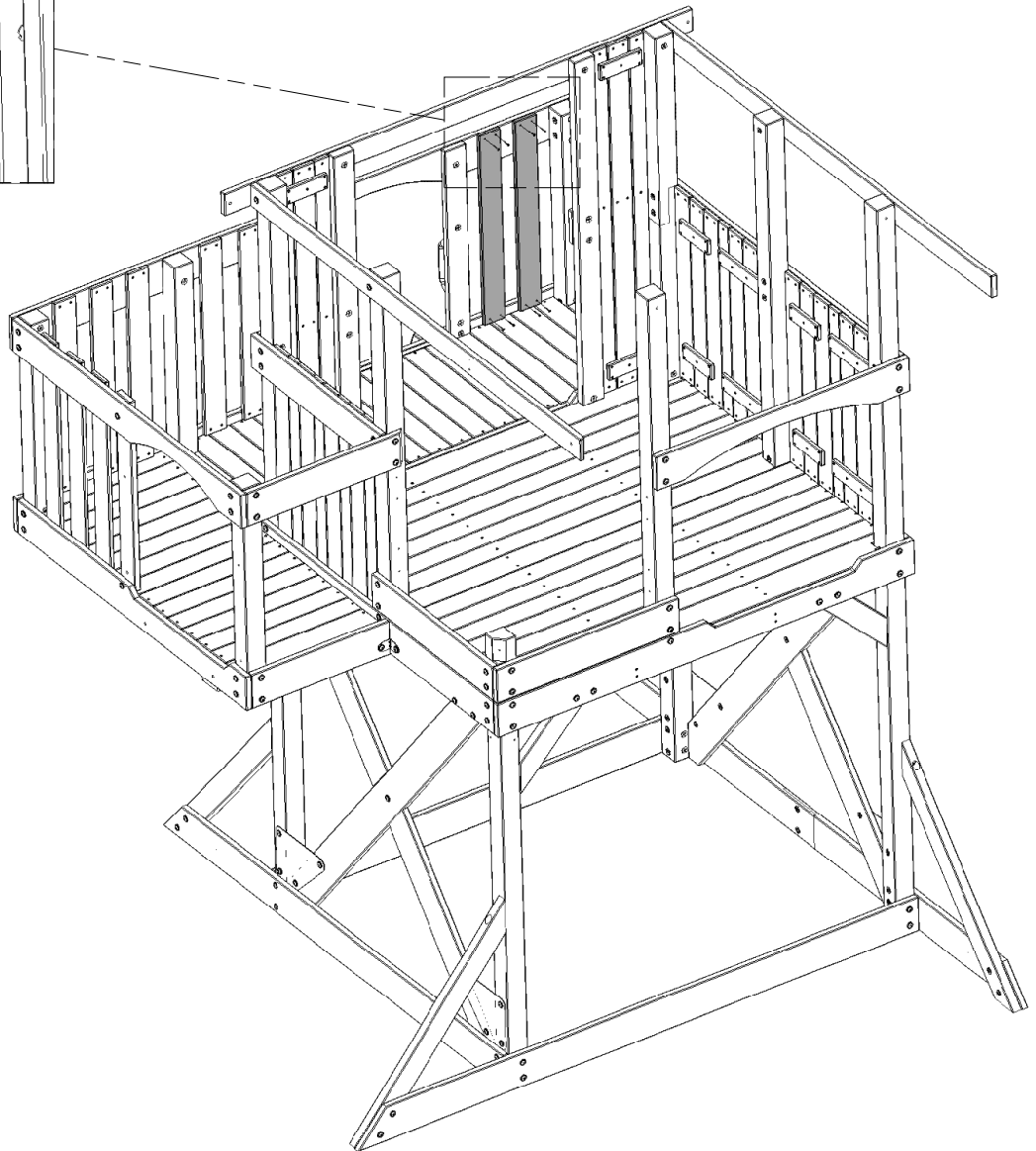
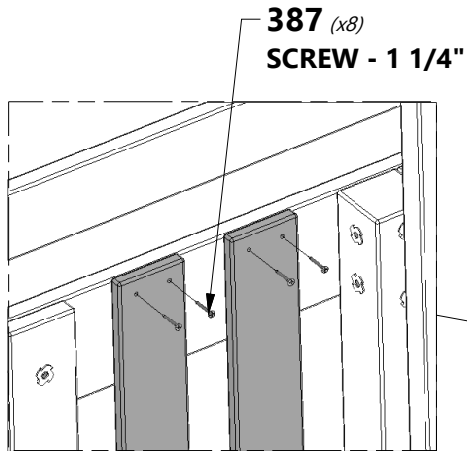

2 3/8 in
[60 mm]
(2 SPCS)

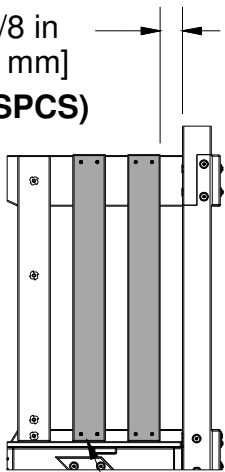

M23 (x2)
WALL PICKET

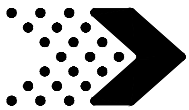

Phase 3

STEP 22



M23 | WALL PICKET - W4L08544
(x3) | 5/8"x3 3/8"x29 7/8" (16x86x759)



H100387 | SCREW PFH BLK
(x12) | 8x1-1/4

2 3/8 in
[60 mm]
(3 SPCS)

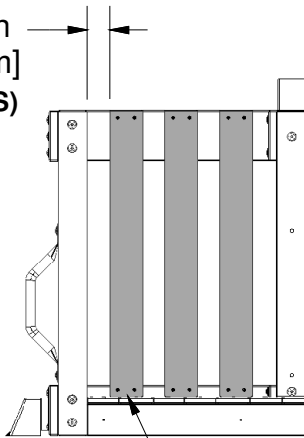

M23 (x3)
WALL PICKET

387 (x12)
SCREW - 1 1/4"

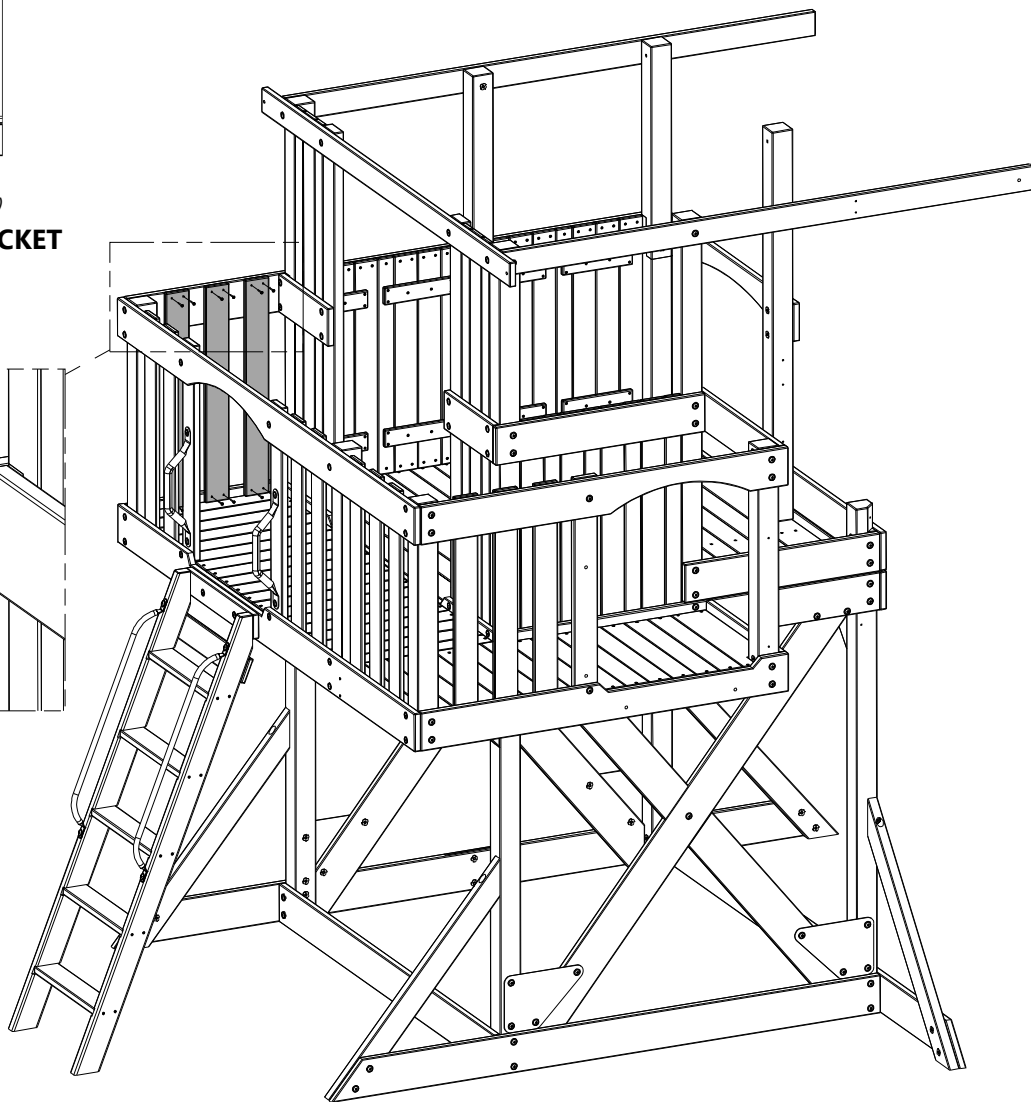

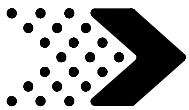

Phase 4

STEP 1



H5 | FLOOR SUPPORT - W4L08479
(x1) | 1"x3 3/8"x32" (24x86x813)



H21 | BASE BOARD - W4L08563
(x1) | 1"x3 3/8"x35" (24x86x889)

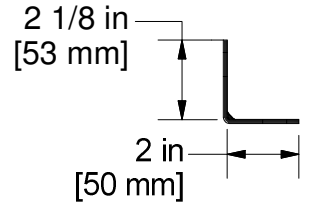

A4M00615 | L BRACKET BLK
(x2)



H100197 | LAG SCREW WH BLK
(x1) | 5/16x2 1/2



H100198 | WASHER LOCK EXT BLK
(x1) | 8x19



H100396 | BOLT WH BLK
(x4) | 5/16x1/2



H100199 | WASHER LOCK EXT BLK
(x2) | 12x19



H100192 | NUT BARREL WH BLK
(x2) | 5/16x7/8



H100379 | T-NUT BLK
(x2) | 5/16



NOTE:

1. ASSEMBLE THE SUB ASSEMBLY FIRST.
2. PRESS SUB ASSEMBLY AGAINST CORNER RAILS AND MARK 'L' BRACKET HOLES.
3. DRILL THROUGH MARKED FLOOR BOARDS USING A 3/8" (10 MM) DRILL BIT.
4. ATTACH SUB ASSEMBLY TO FORT FLOOR USING HARDWARE SHOWN BELOW.



TIP:

WE RECOMMEND INSTALLING T-NUTS INTO BOARDS BEFORE ASSEMBLY.

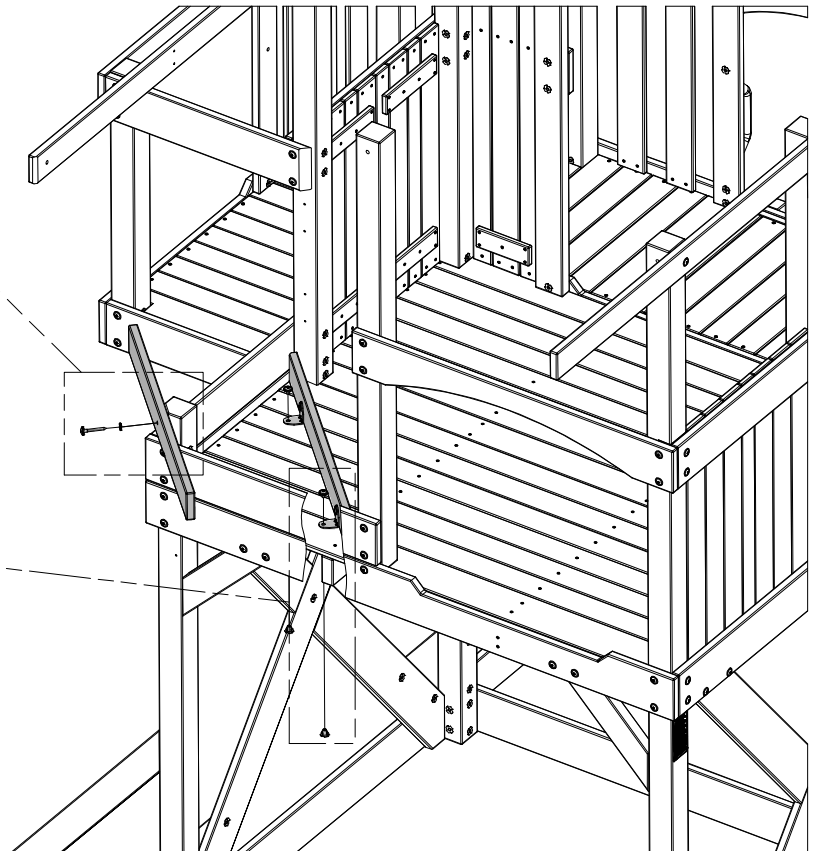
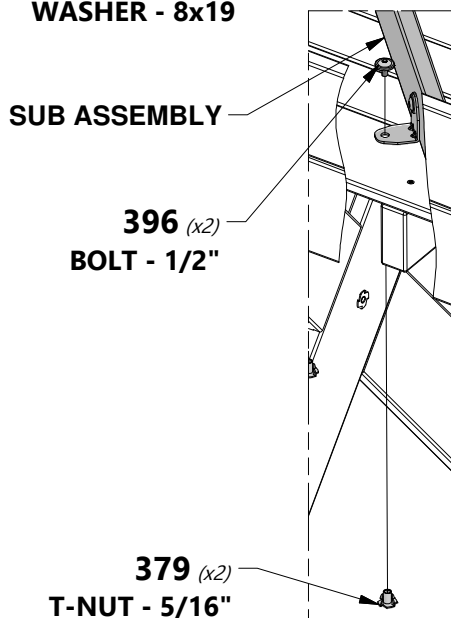
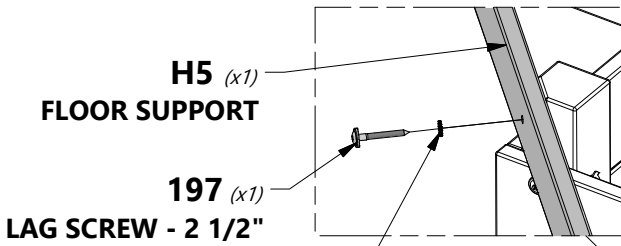
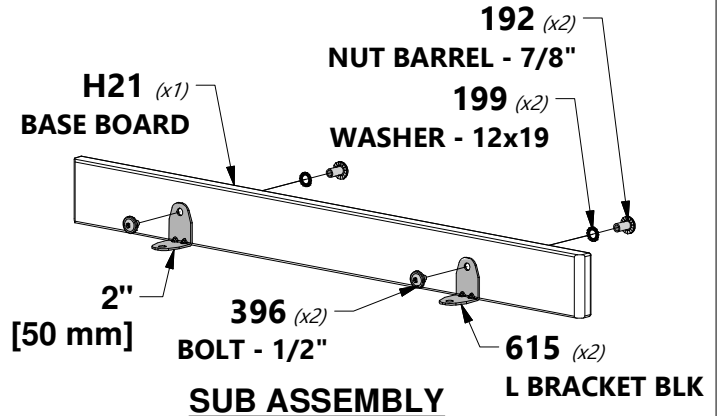

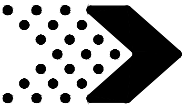

Phase 4

STEP 2

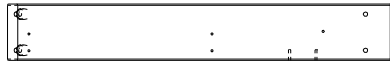

G7 | WALL SUPPORT - W4L12842
(x1) | 1"x5 1/4"x36" (24x134x915)

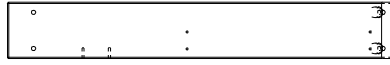

G10 | WALL SUPPORT - W4L08481
(x1) | 1"x5 1/4"x36" (24x134x915)



H100197 | LAG SCREW WH BLK
(x4) | 5/16x2 1/2



H100198 | WASHER LOCK EXT BLK
(x4) | 8x19



H100391 | SCREW PFH BLK
(x4) | 8x2

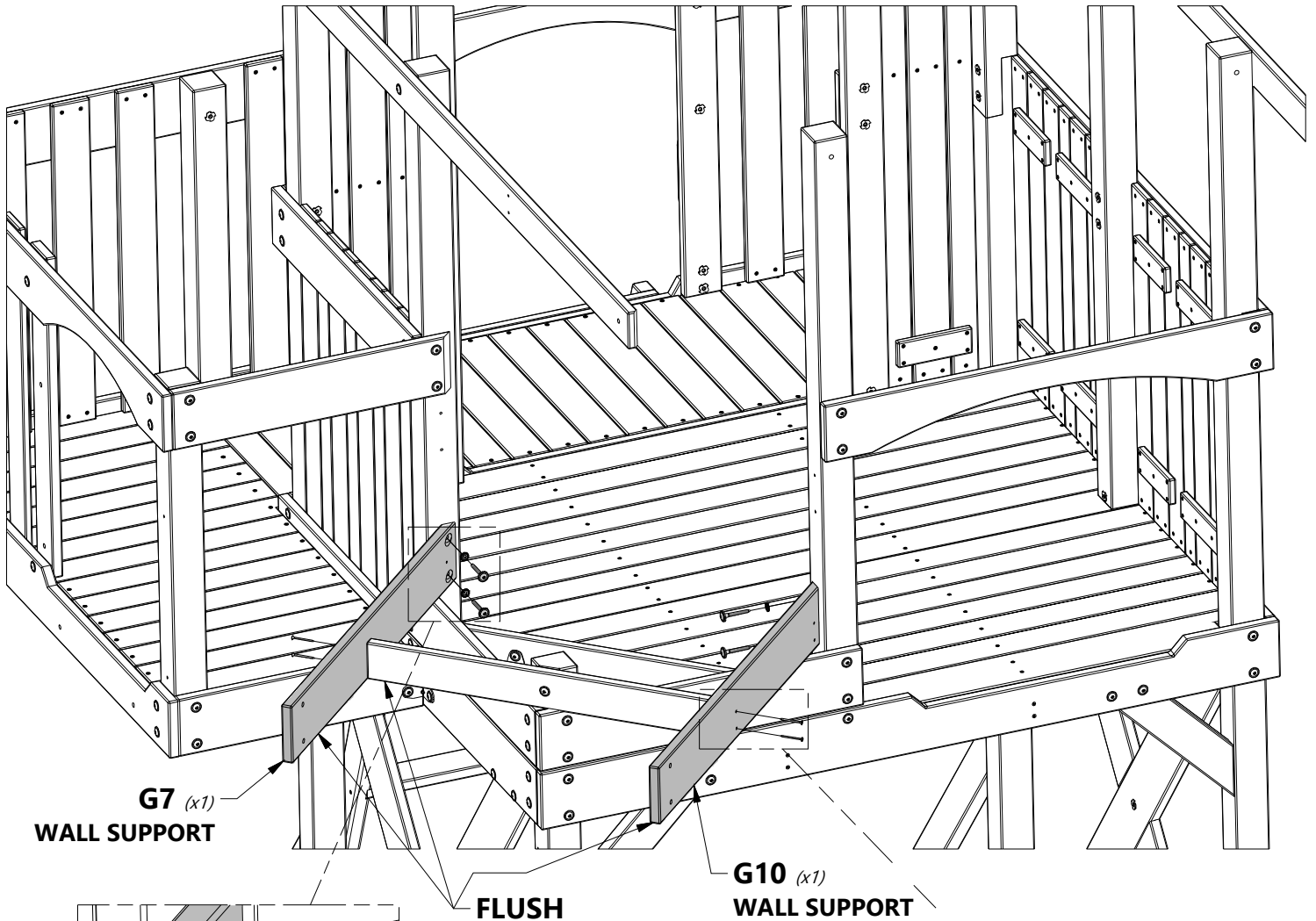

G7 (x1)
WALL SUPPORT

G10 (x1)
WALL SUPPORT

FLUSH

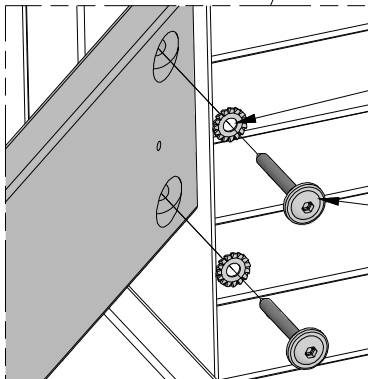

198 (x4)
WASHER - 8x19

197 (x4)
LAG SCREW - 2 1/2"

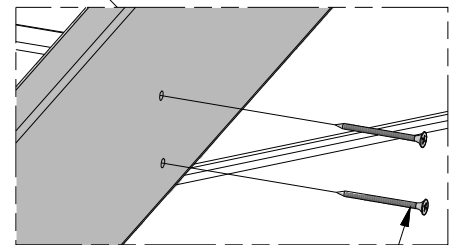

391 (x4)
SCREW - 2"

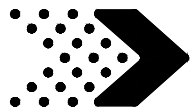

Phase 4

STEP 3

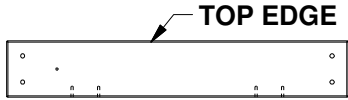

G8 | WALL SUPPORT - W4L12843
(x1) | 1"x5 1/4"x32" (24x134x813)



B10 | POST - W4L08484
(x1) | 3"x3"x47 1/4" (76x76x1201)

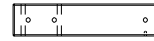

B12 | POST - W4L08487
(x1) | 3"x3"x13 5/8" (76x76x345)



H100415 | BOLT WH BLK
(x8) | 5/16x3 3/4



H100458 | LAG SCREW WH BLK
(x1) | 5/16x2



H100379 | T-NUT BLK
(x8) | 5/16



H100198 | WASHER LOCK EXT BLK
(x9) | 8x19



TIP:
WE RECOMMEND INSTALLING T-NUTS INTO
BOARDS BEFORE ASSEMBLY.

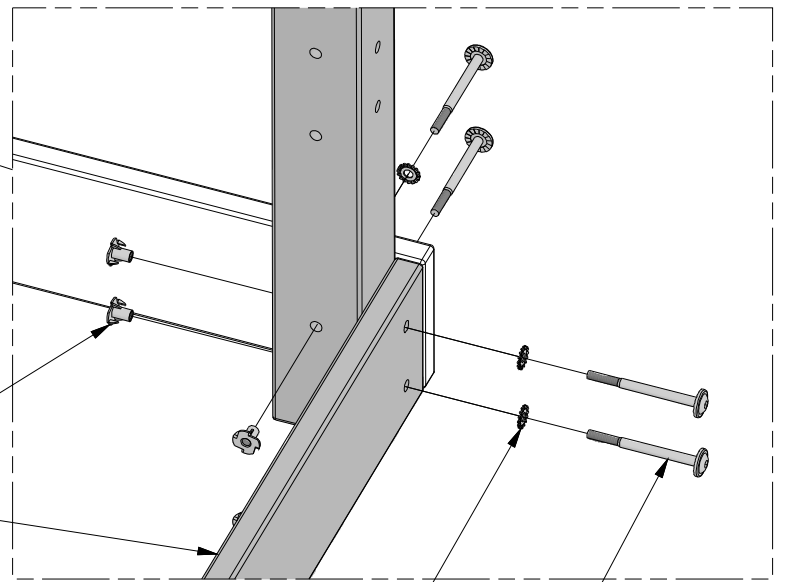
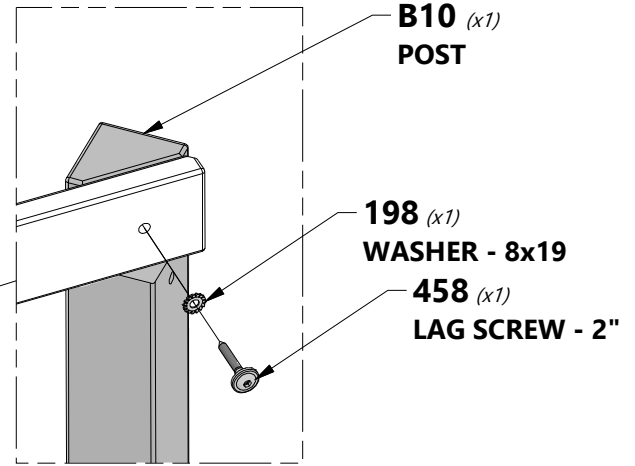
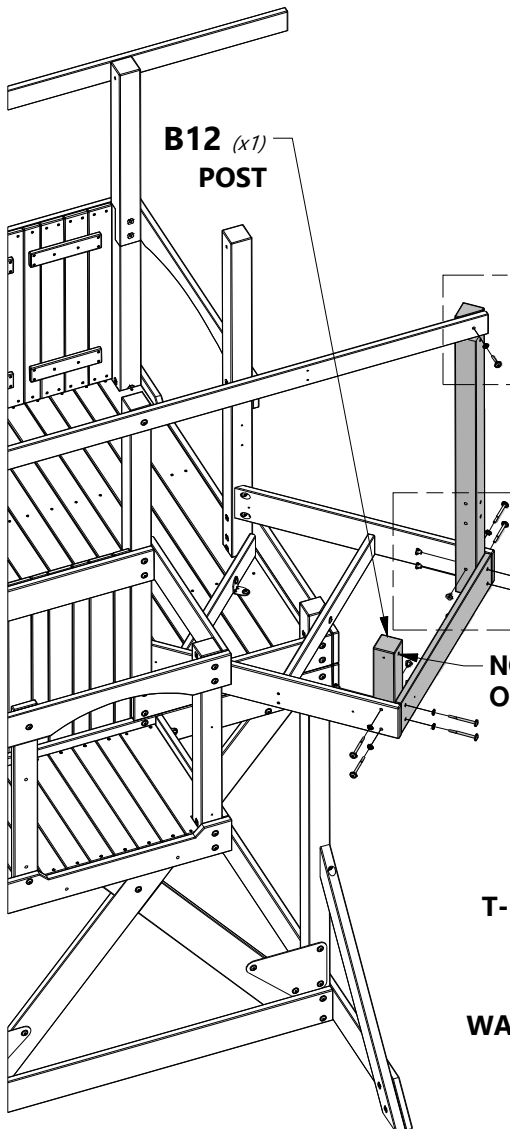

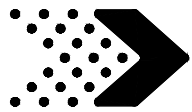

Phase 4

STEP 4

H7 | FLOOR SUPPORT - W4L08483
(x1) | 1"x3 3/8"x26" (24x86x661)

H20 | FLOOR SUPPORT - W4L08562
(x2) | 1"x2 3/4"x3" (24x70x76)

H6 | FLOOR SUPPORT - W4L08482
(x1) | 1"x3 3/8"x32" (24x86x813)

H100382 | SCREW PFH BLK
(x3) | 8x1 3/4

H100391 | SCREW PFH BLK
(x8) | 8x2

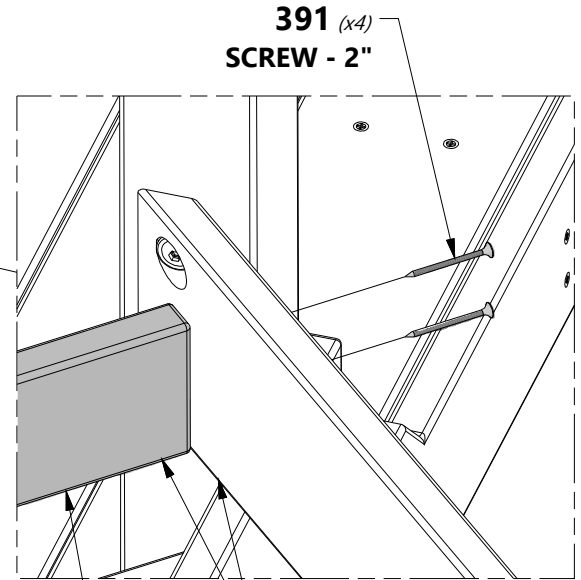
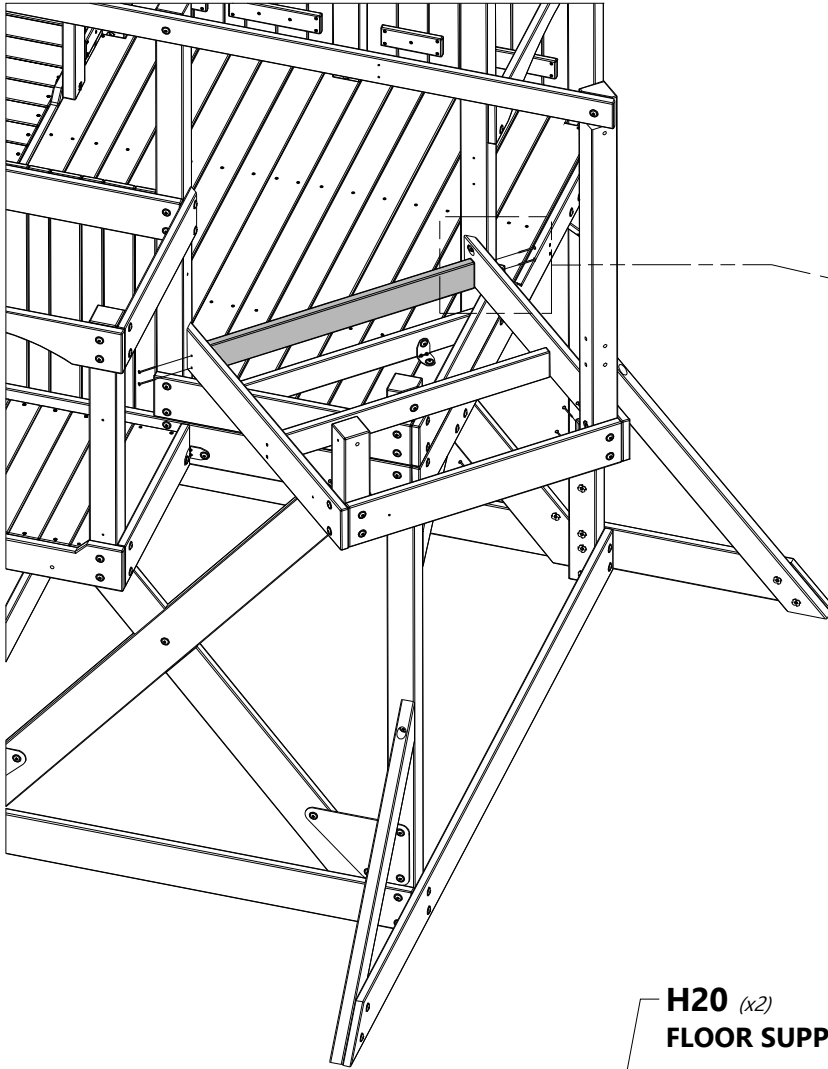

391 (x4)
SCREW - 2"

FLUSH

H6 (x1)
FLOOR SUPPORT

382 (x3)
SCREW - 1 3/4"

THESE (2) BOARDS HAVE
FLUSH BOTTOM EDGES.

H20 (x2)
FLOOR SUPPORT

H7 (x1)
FLOOR SUPPORT

FLUSH
AT TOP.

391 (x4)
SCREW - 2"

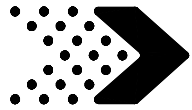

Phase 4

STEP 5



E8 | ANGLE SUPPORT BRACE - W4L12935
(x2) | 1 3/8"x3 3/8"x25 3/8" (36x86x643)



G5 | CROSS BRACE - W4L12915
(x2) | 1"x5 1/4"x17 3/4" (24x134x450)



H100484 | BOLT WH BLK
(x2) | 5/16x3 1/4



H100482 | LAG SCREW WH BLK
(x2) | 5/16x3 1/2



H100379 | T-NUT BLK
(x2) | 5/16



H100198 | WASHER LOCK EXT BLK
(x4) | 8x19



H100487 | LAG SCREW WH BLK
(x8) | 1/4x2



NOTE:

1. ASSEMBLE THE SUB ASSEMBLIES FIRST. (NOTE: THERE IS A LEFT & RIGHT ASSEMBLY).
2. ATTACH SUB ASSEMBLIES TO TURRET DECK FLOOR USING HARDWARE SHOWN BELOW.



TIP:

WE RECOMMEND INSTALLING T-NUTS INTO BOARDS BEFORE ASSEMBLY.

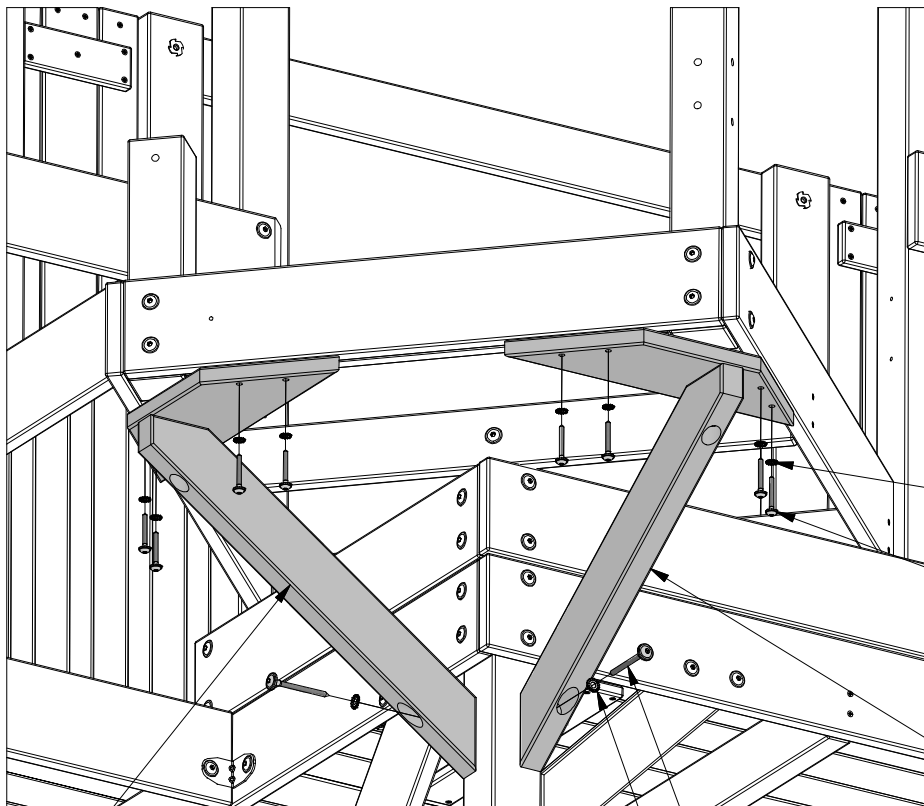
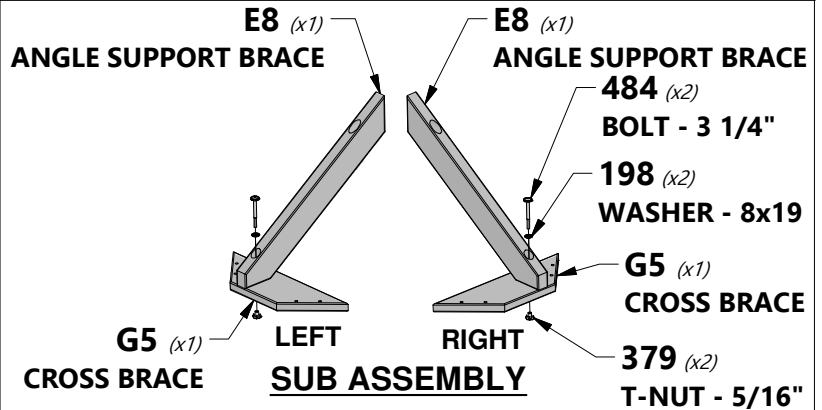

405 (x8) WASHER - 6x15

487 (x8) LAG SCREW - 2"

LEFT SUB ASSEMBLY

RIGHT SUB ASSEMBLY

198 (x2) WASHER - 8x19

482 (x2) LAG SCREW - 3 1/2"

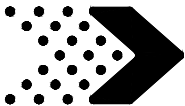

Phase 4

STEP 6

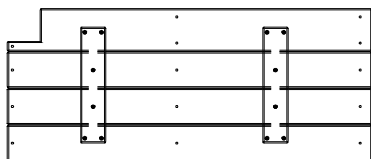

FP8 | FLOOR PANEL - W2A02912
(x1) | 1 1/4"x14 5/16"x34 3/16" (32x363x869)

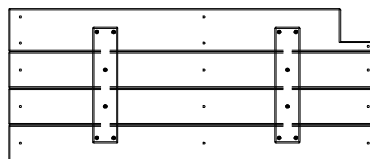

FP9 | FLOOR PANEL - W2A02913
(x1) | 1 1/4"x14 5/16"x34 3/16" (32x363x869)

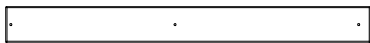

M1 | FLOOR BOARD - W4L08489
(x1) | 5/8"x3 3/8"x34 1/4" (16x86x869)



H100200 | SCREW PFH BLK
(x31) | 8x1 1/2"

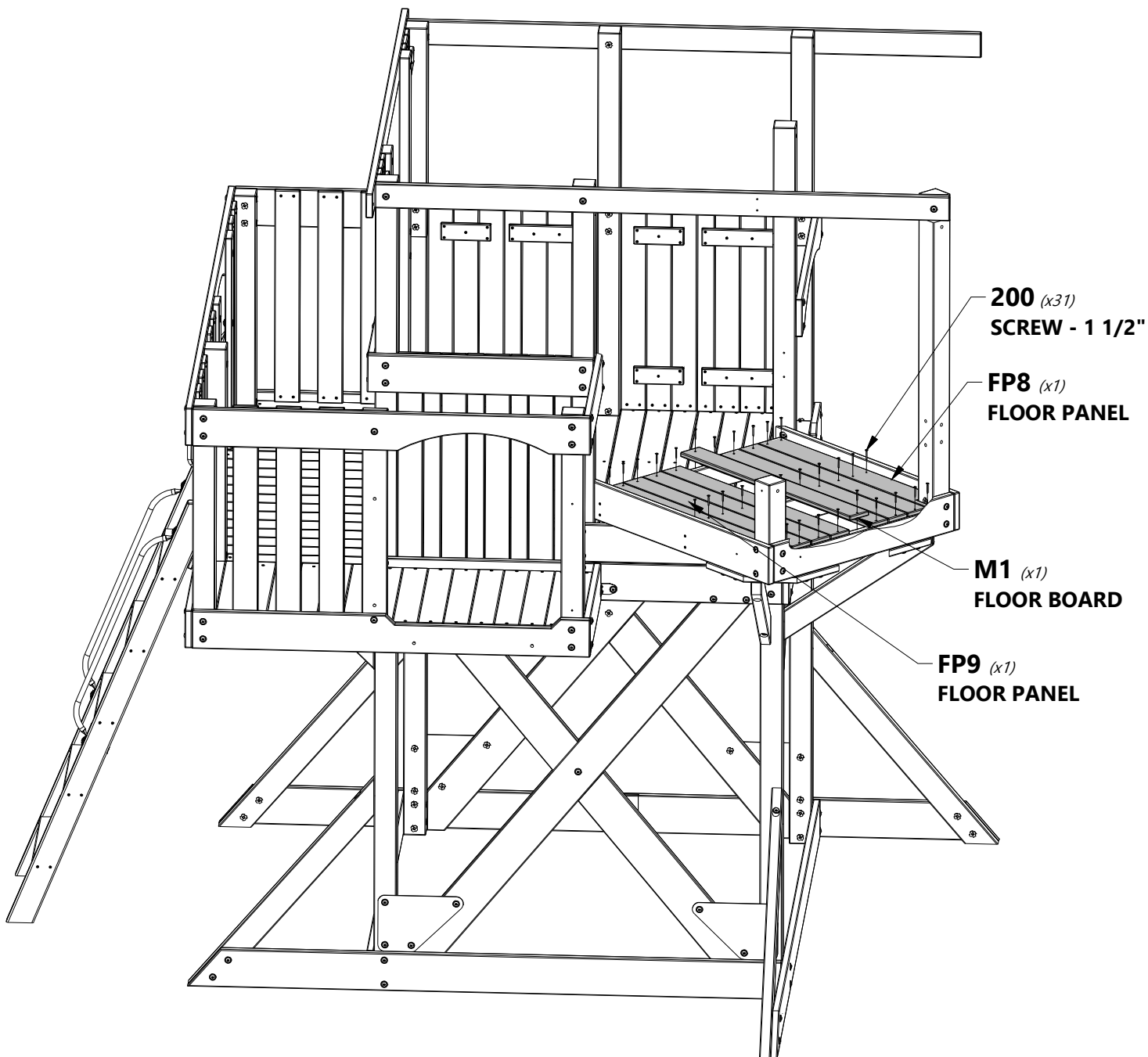

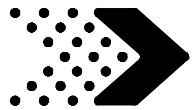

Phase 4

STEP 7



G11 | WALL SUPPORT - W4L08486
(x1) | 1"x5 1/4"x7 1/2" (24x134x192)



G14 | WALL SUPPORT - W4L08492
(x1) | 1"x5 1/4"x10 5/8" (24x134x269)



G26 | WALL SUPPORT - W4L08485
(x1) | 1"x5 1/4"x36" (24x134x915)



H100197 | LAG SCREW WH BLK
(x4) | 5/16x2 1/2



H100379 | T-NUT BLK
(x4) | 5/16



H100415 | BOLT WH BLK
(x4) | 5/16x3 3/4



H100198 | WASHER LOCK EXT BLK
(x8) | 8x19



TIP:

WE RECOMMEND INSTALLING T-NUTS INTO BOARDS BEFORE ASSEMBLY.

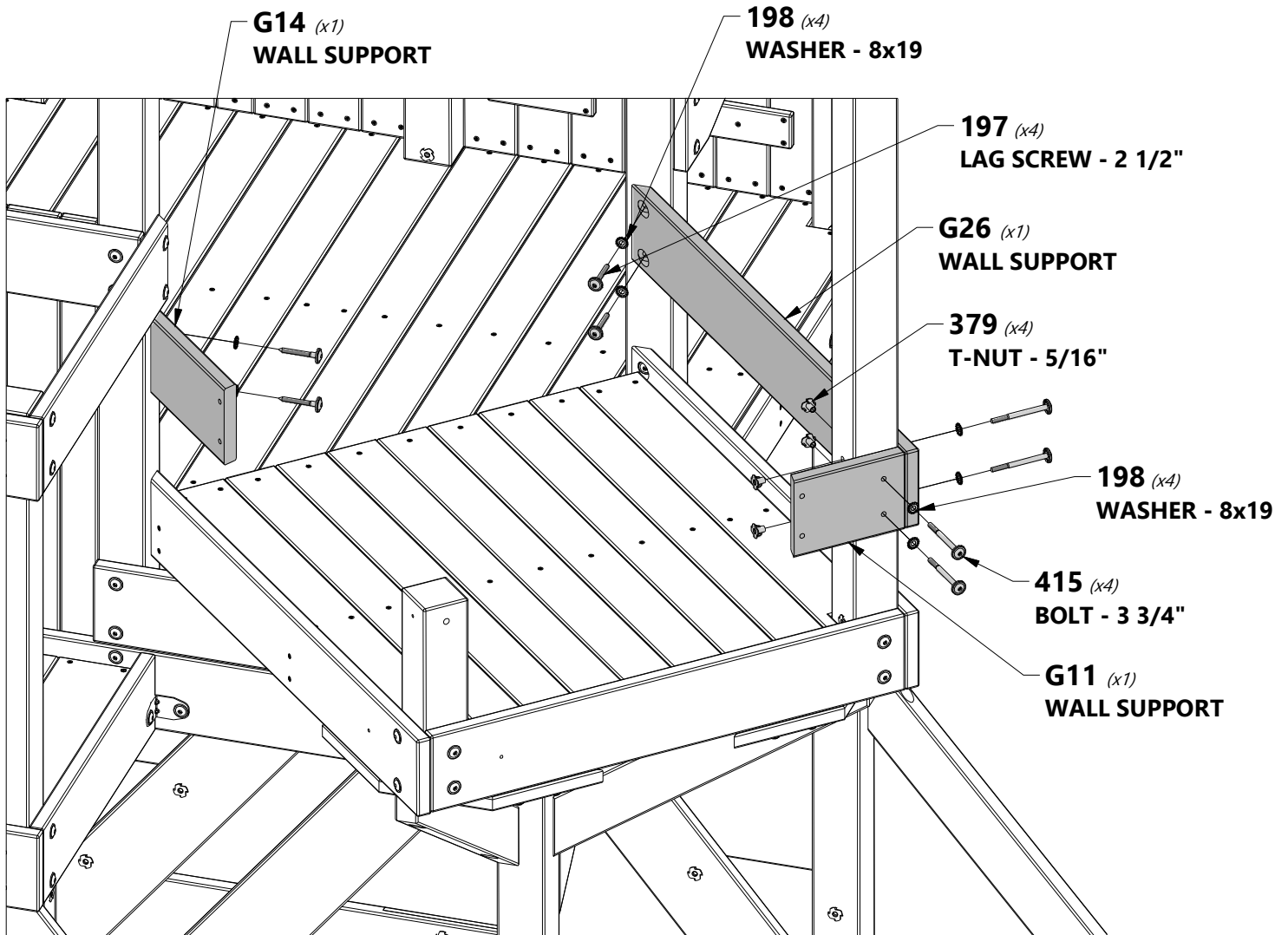

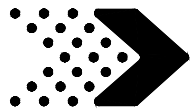

Phase 4

STEP 8



J2 | FLOOR SUPPORT - W4L12844
(x1) | 1"x2 3/8"x23 3/8" (24x60x594)



J3 | FLOOR SUPPORT - W4L12845
(x1) | 1"x2 3/8"x24 3/8" (24x60x619)



H100415 | BOLT WH BLK
(x1) | 5/16x3 3/4



H100458 | LAG SCREW WH BLK
(x1) | 5/16x2



H100379 | T-NUT BLK
(x1) | 5/16



H100198 | WASHER LOCK EXT BLK
(x2) | 8x19



TIP:
WE RECOMMEND INSTALLING T-NUTS INTO BOARDS BEFORE ASSEMBLY.

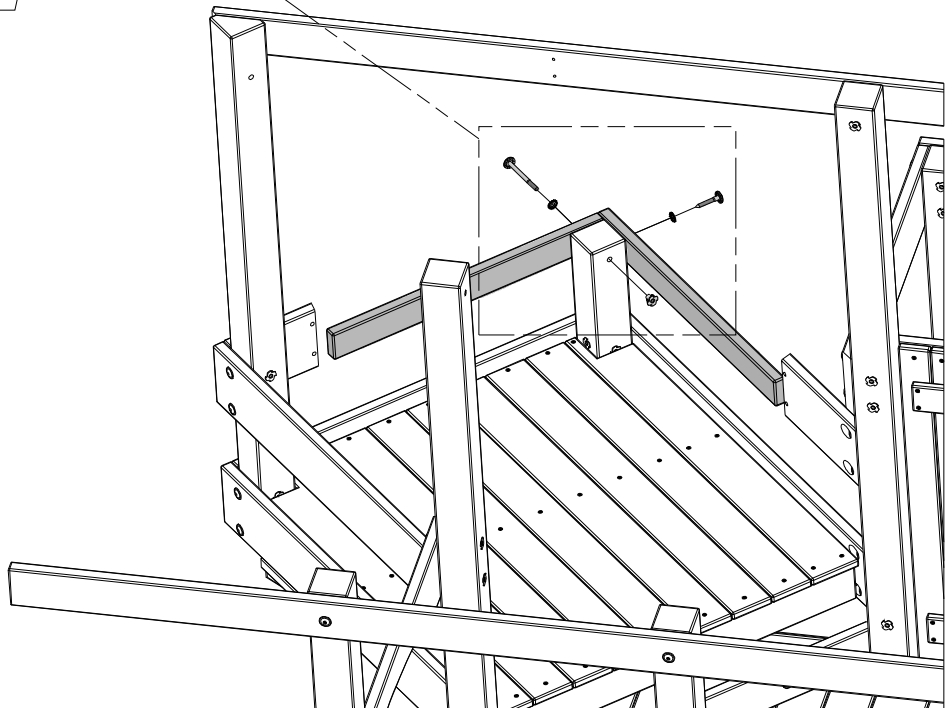
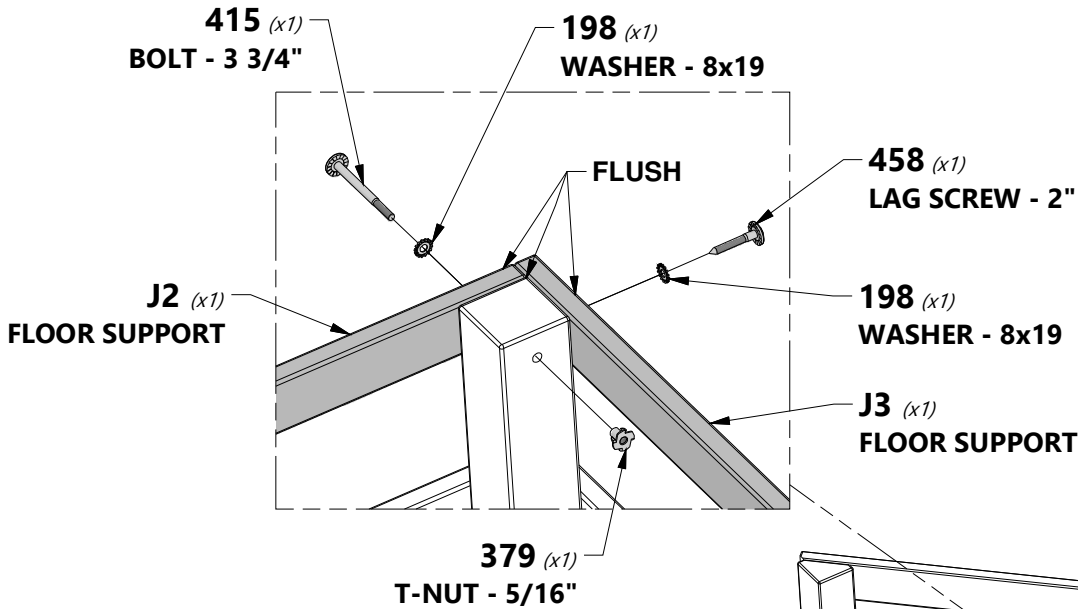

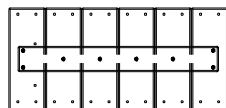
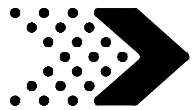

WP6 | WALL PANEL - W2A02908
(x1) | 1/16"x1/16"x1/16" (32x243x521)

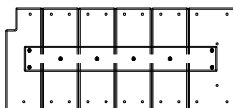

WP7 | WLL PANEL - W2A02909
(x1) | 1/16"x1/16"x1/16" (32x547x243)



H100387 | SCREW PFH BLK
(x46) | 8x1-1/4

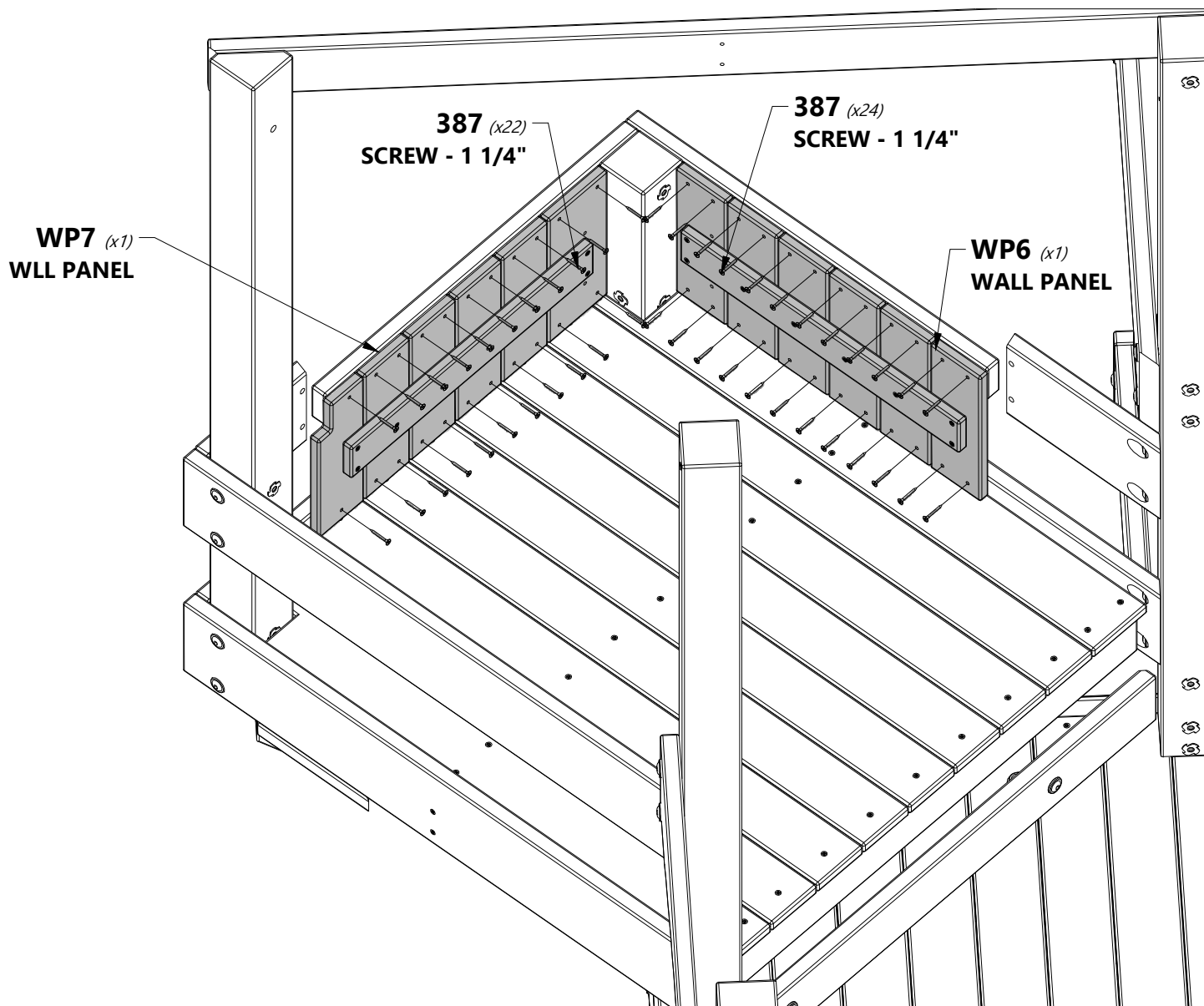

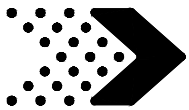

H17 | WALL SUPPORT - W4L08533
(x1) | 1"x3 3/8"x35" (24x86x889)



H100391 | SCREW PFH BLK
(x4) | 8x2

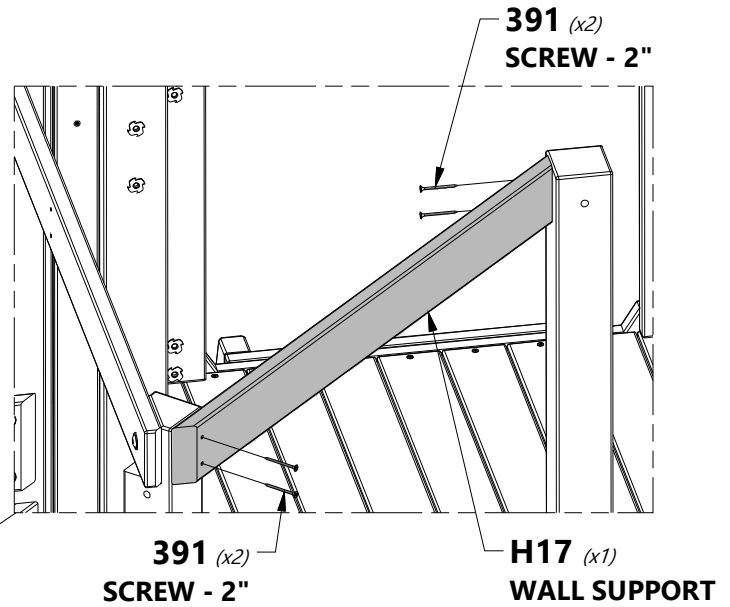
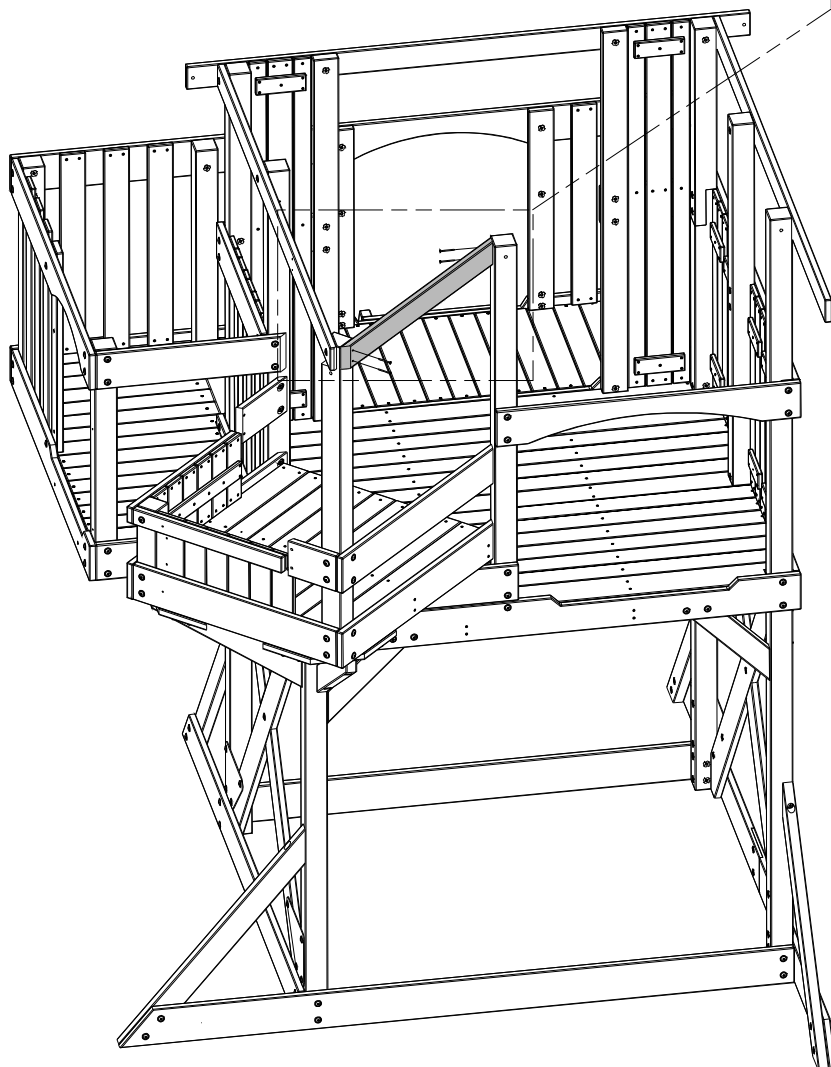

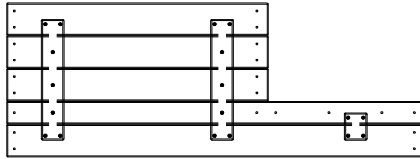
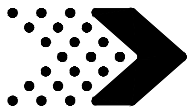

WP8 | LEFT WINDOW WALL PANEL - W2A02910
(x1) | 1 1/4"x16"x43 1/4" (32x407x1099)

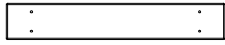

M20 | WALL BOARD - W4L08536
(x1) | 5/8"x3 3/8"x20 1/2" (16x86x521)

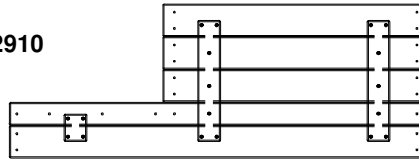

WP9 | RIGHT WINDOW WALL PANEL - W2A02911
(x1) | 1 1/4"x15 7/8"x43 1/4" (32x404x1099)



H100387 | SCREW PFH BLK
(x28) | 8x1-1/4



NOTE:

INSTALL 'WP8' AND 'WP9' PANELS BEFORE INSTALLING 'M20' BOARD.

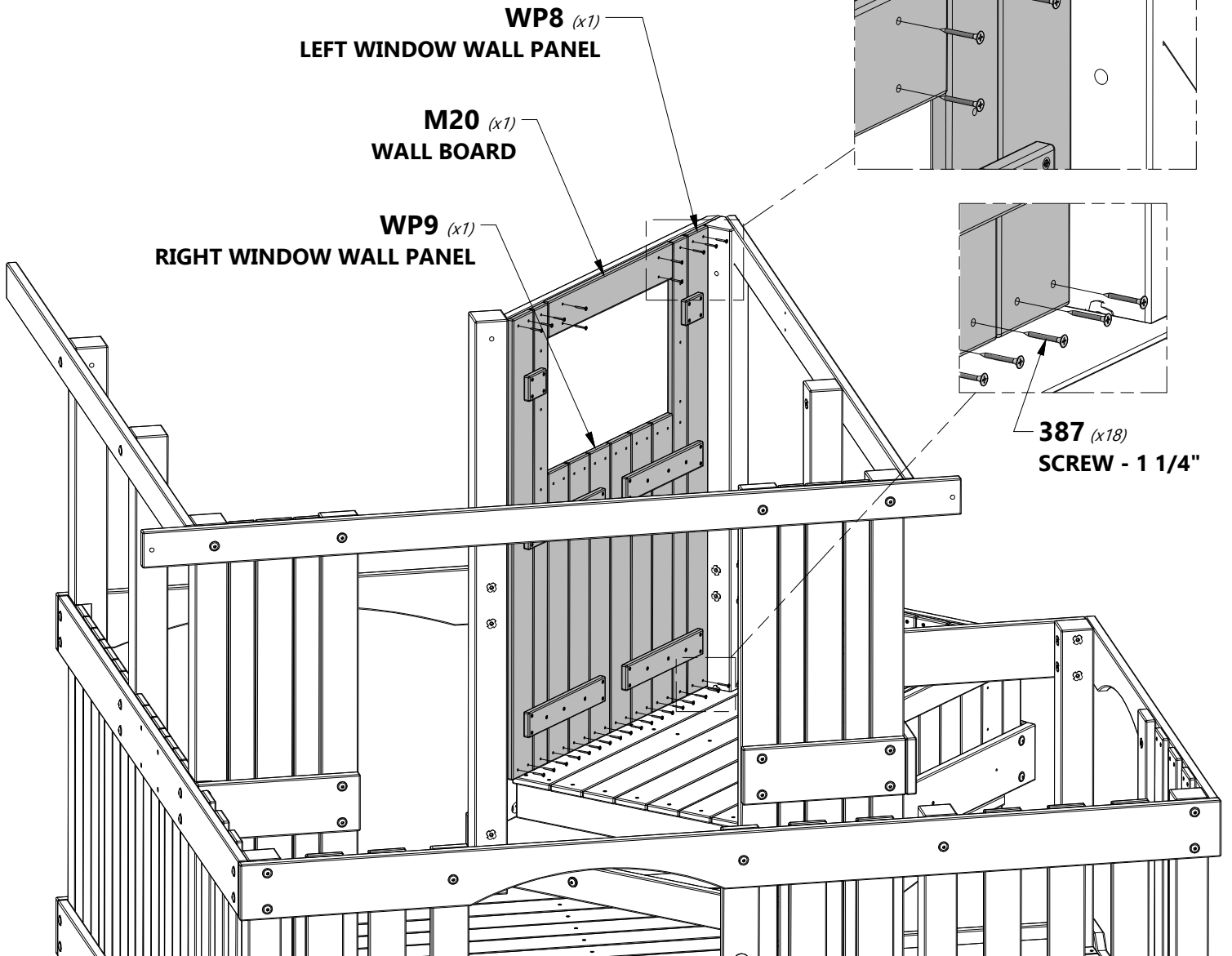

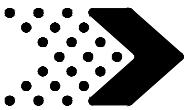

Phase 4

STEP 12



N2 | WINDOW BOTTOM - W4L08538
(x1) | 5/8"x2 3/8"x25 1/4" (16x60x640)



N3 | WINDOW SIDE - W4L08539
(x2) | 5/8"x2 3/8"x12 5/8" (16x60x321)



H100380 | SCREW PFH BLK
(x20) | 8x1 1/8"

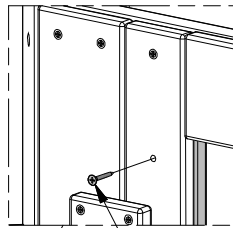

380 (x20)
SCREW - 1 1/8"

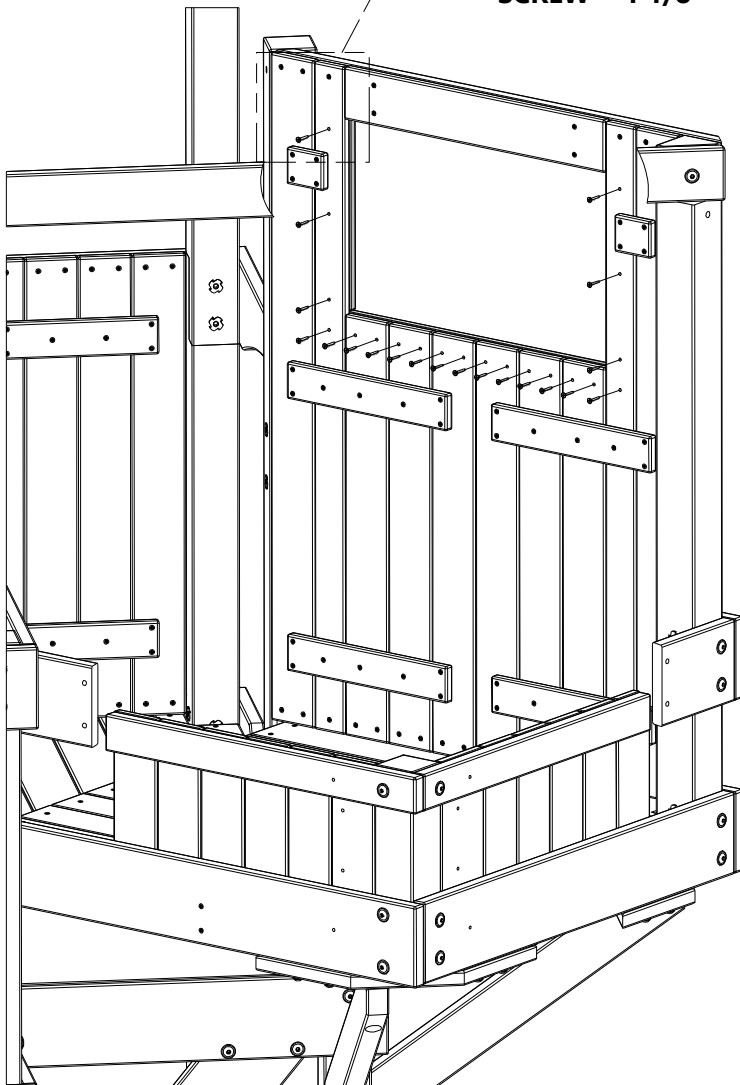

INSIDE VIEW

N3 (x2)
WINDOW SIDE

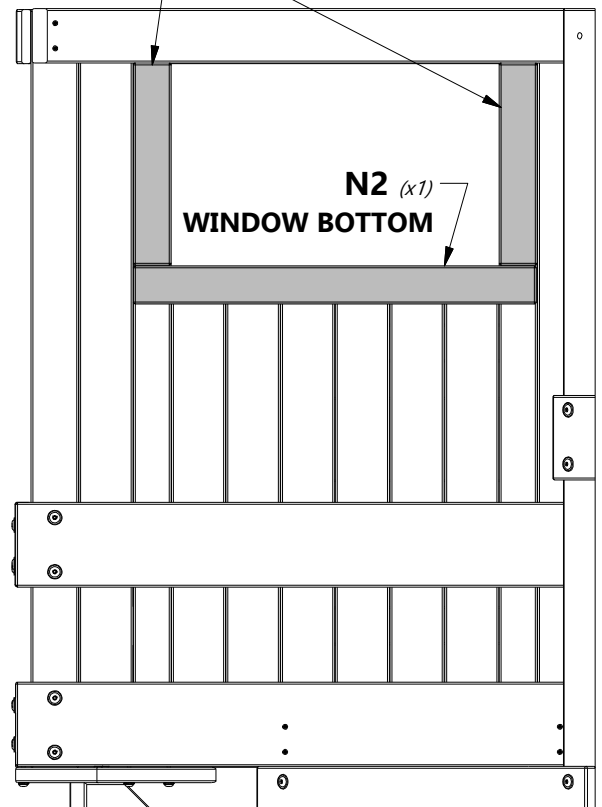

N2 (x1)
WINDOW BOTTOM

OUTSIDE VIEW

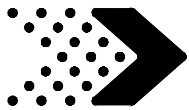

Phase 4

STEP 13



H12 | ROOF SUPPORT - W4L08519
(x1) | 1"x3 3/8"x39 1/2" (24x86x1004)



H18 | ROOF SUPPORT - W4L08541
(x1) | 1"x3 3/8"x28 1/4" (24x86x717)



H100415 | BOLT WH BLK
(x1) | 5/16x3 3/4



H100534 | BOLT WH BLK
(x1) | 5/16x4 1/2



H100379 | T-NUT BLK
(x1) | 5/16



H100198 | WASHER LOCK EXT BLK
(x2) | 8x19



H100199 | WASHER LOCK EXT BLK
(x1) | 12x19



H100192 | NUT BARREL WH BLK
(x1) | 5/16x7/8



H100391 | SCREW PFH BLK
(x2) | 8x2



TIP:

WE RECOMMEND INSTALLING T-NUTS INTO BOARDS BEFORE ASSEMBLY.

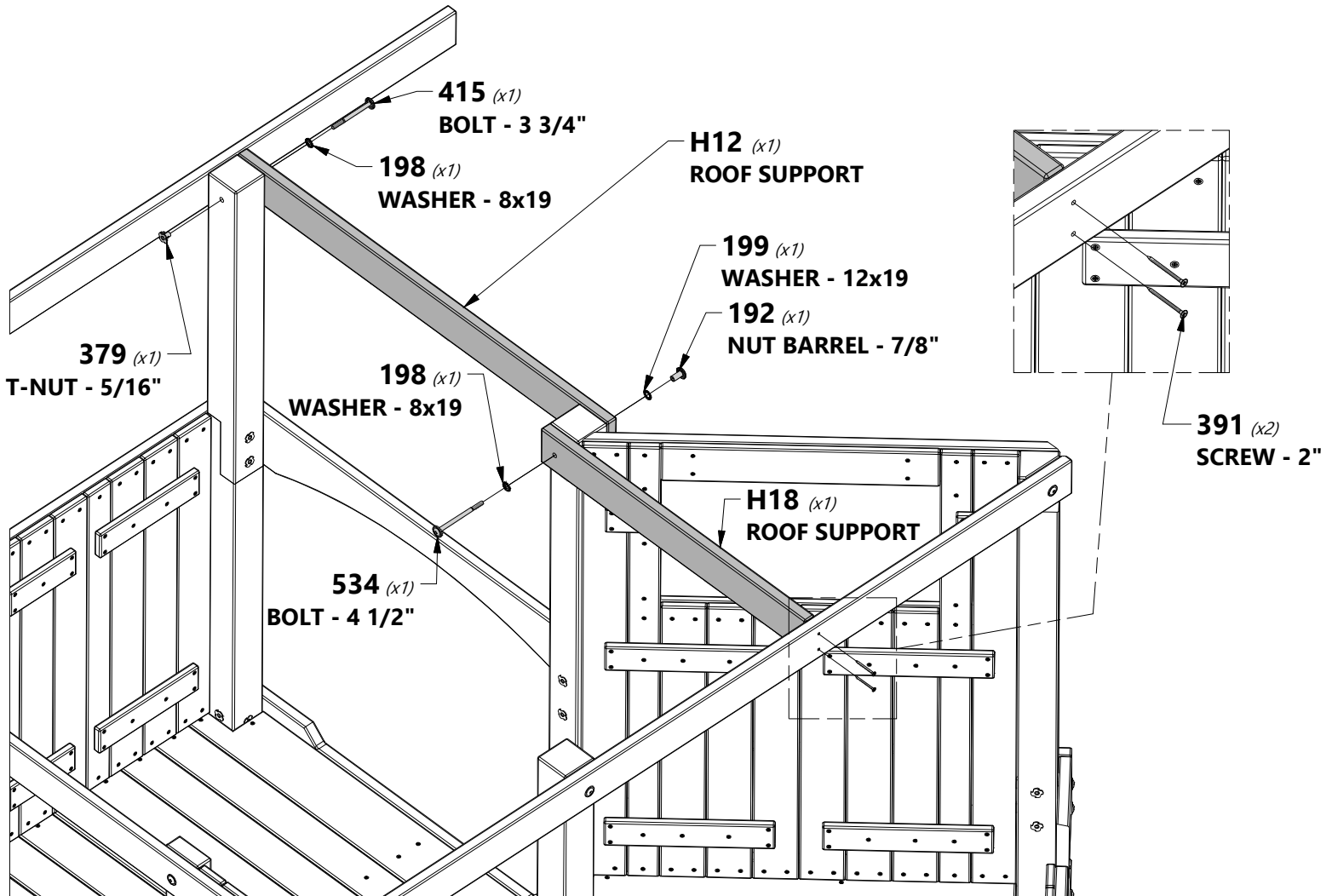

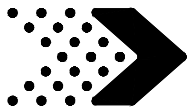

H14 | ROOF SUPPORT - W4L08521
(x1) | 1"x3 3/8"x74 3/4" (24x86x1900)



H100391 | SCREW PFH BLK
(x4) | 8x2

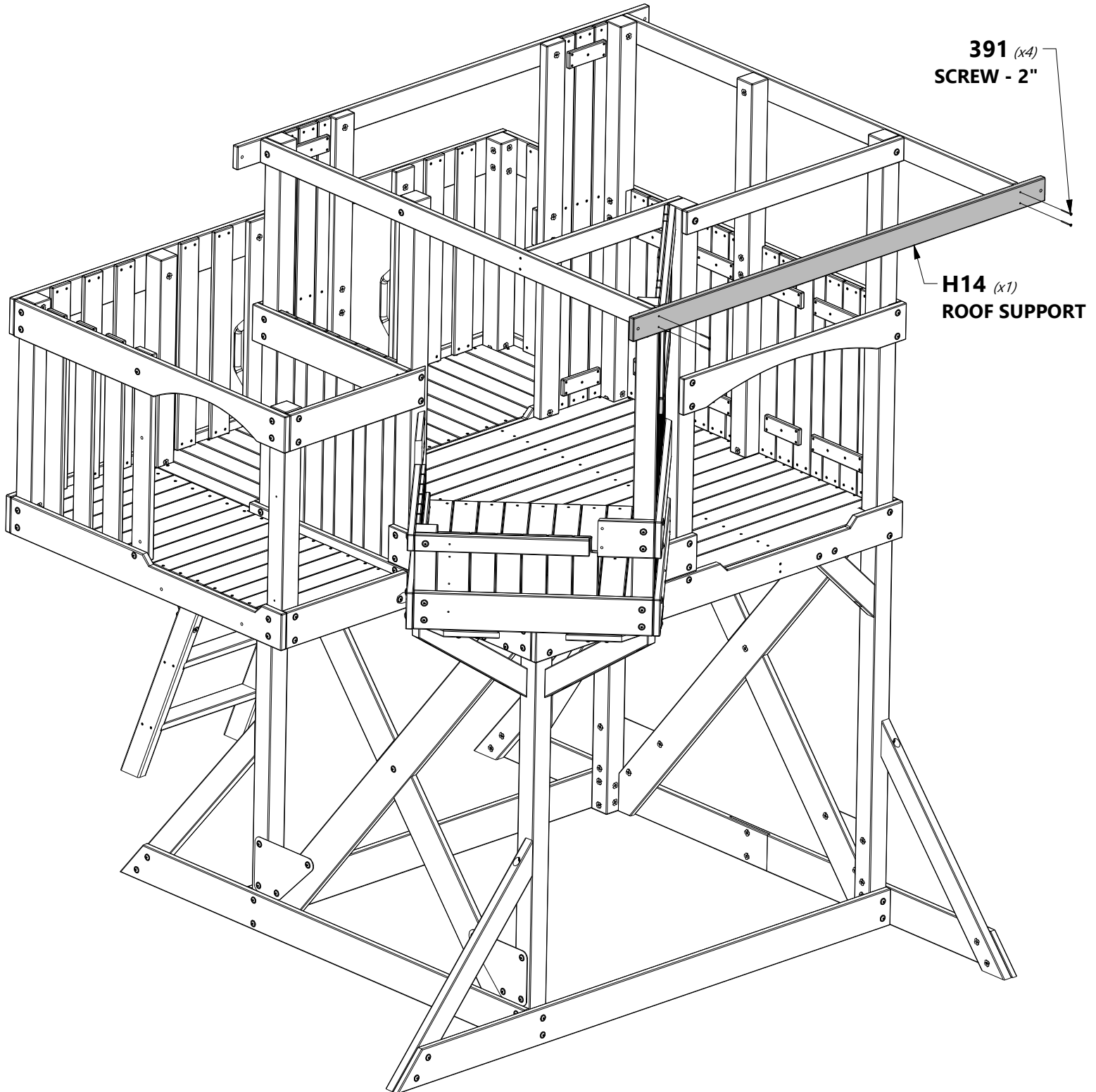

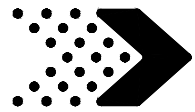

Phase 4

STEP 15



T2 | WALL BOARD - W4L12846
(x2) | 1"x1 3/8"x5 7/8" (24x34x150)



H100200 | SCREW PFH BLK
(x4) | 8x1 1/2

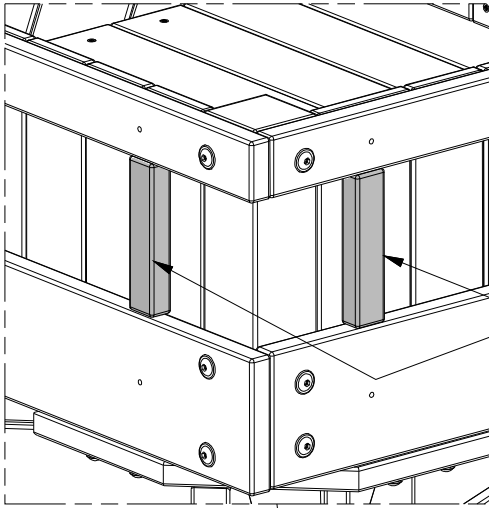

T2 (x2)
WALL BOARD

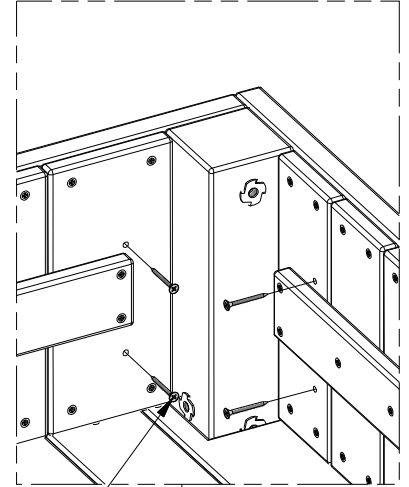

200 (x4)
SCREW - 1 1/2"

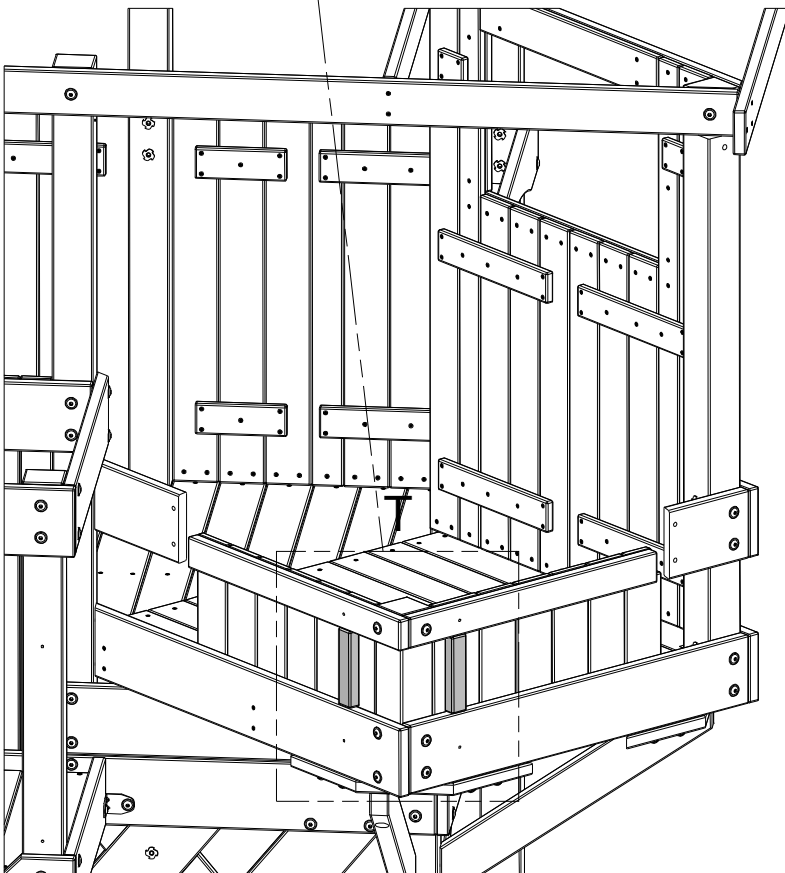

OUTSIDE VIEW

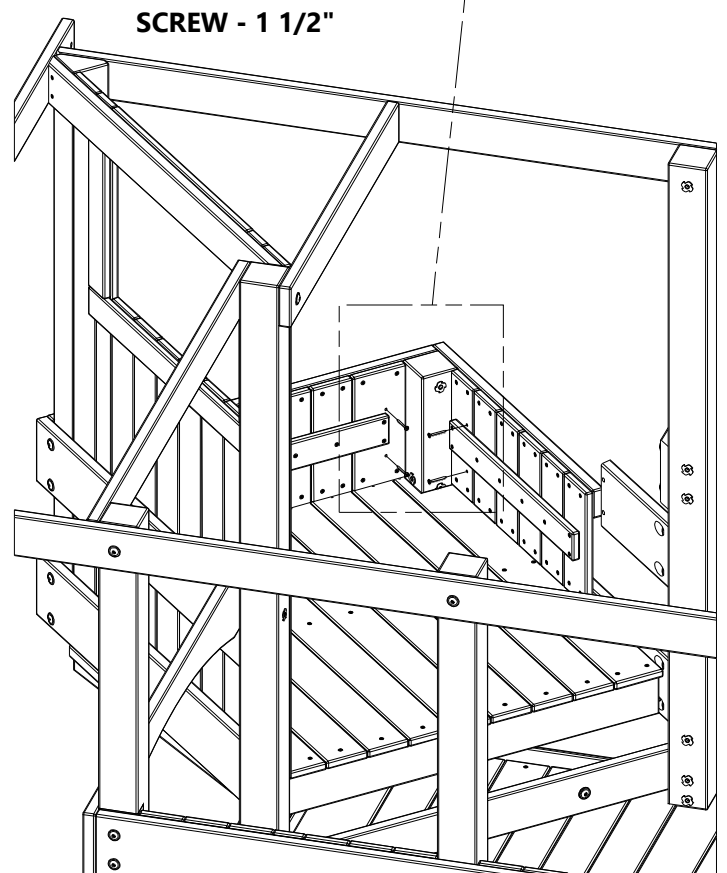

INSIDE VIEW

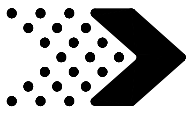

Phase 5

STEP 1



F1 | **POST - W4L08495**
(x2) | 1 3/8"x2 3/8"x54 5/8" (36x60x1389)



J1 | **WALL SUPPORT - W4L08496**
(x1) | 1"x2 3/8"x27 1/8" (24x60x688)

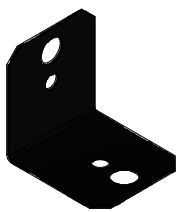

A4M00555 | **90° L-BRACKET - BLK**
(x2)



H100200 | **SCREW PFH BLK**
(x4) | 8x1-1/2



H100392 | **SCREW PWH BLK**
(x2) | 8x3/4

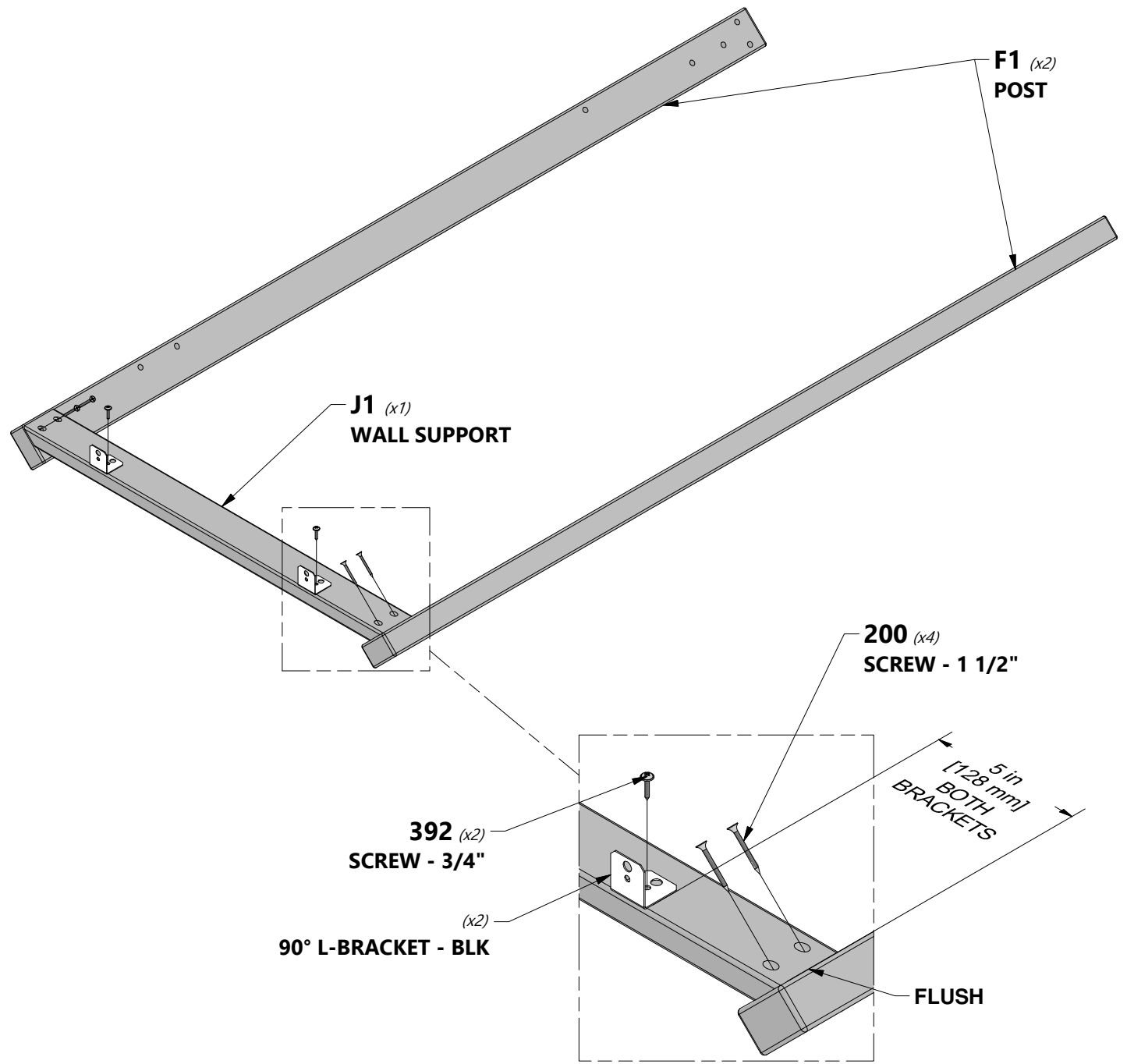

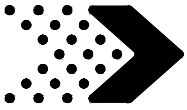

Phase 5

STEP 2



F2 | POST - W4L08503
(x1) | 1 3/8"x2 3/8"x47 1/4" (36x60x1200)

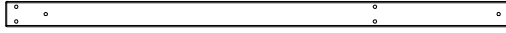

F3 | POST - W4L08504
(x1) | 1 3/8"x2 3/8"x47 1/4" (36x60x1200)

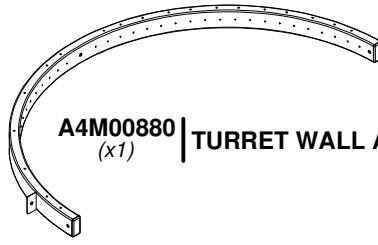

A4M00880 | TURRET WALL ARCH BAND
(x1)



A4M00881 | QUARTER ROUND TURRET FLOOR SUPPORT
(x1)



H100800 | BOLT WH BLK
(x2) | 1/4x3



H100567 | BOLT WH BLK
(x3) | 1/4x2 1/4



H100398 | T-NUT BLK
(x5) | 1/4



TIP:
WE RECOMMEND INSTALLING T-NUTS INTO
BOARDS BEFORE ASSEMBLY.

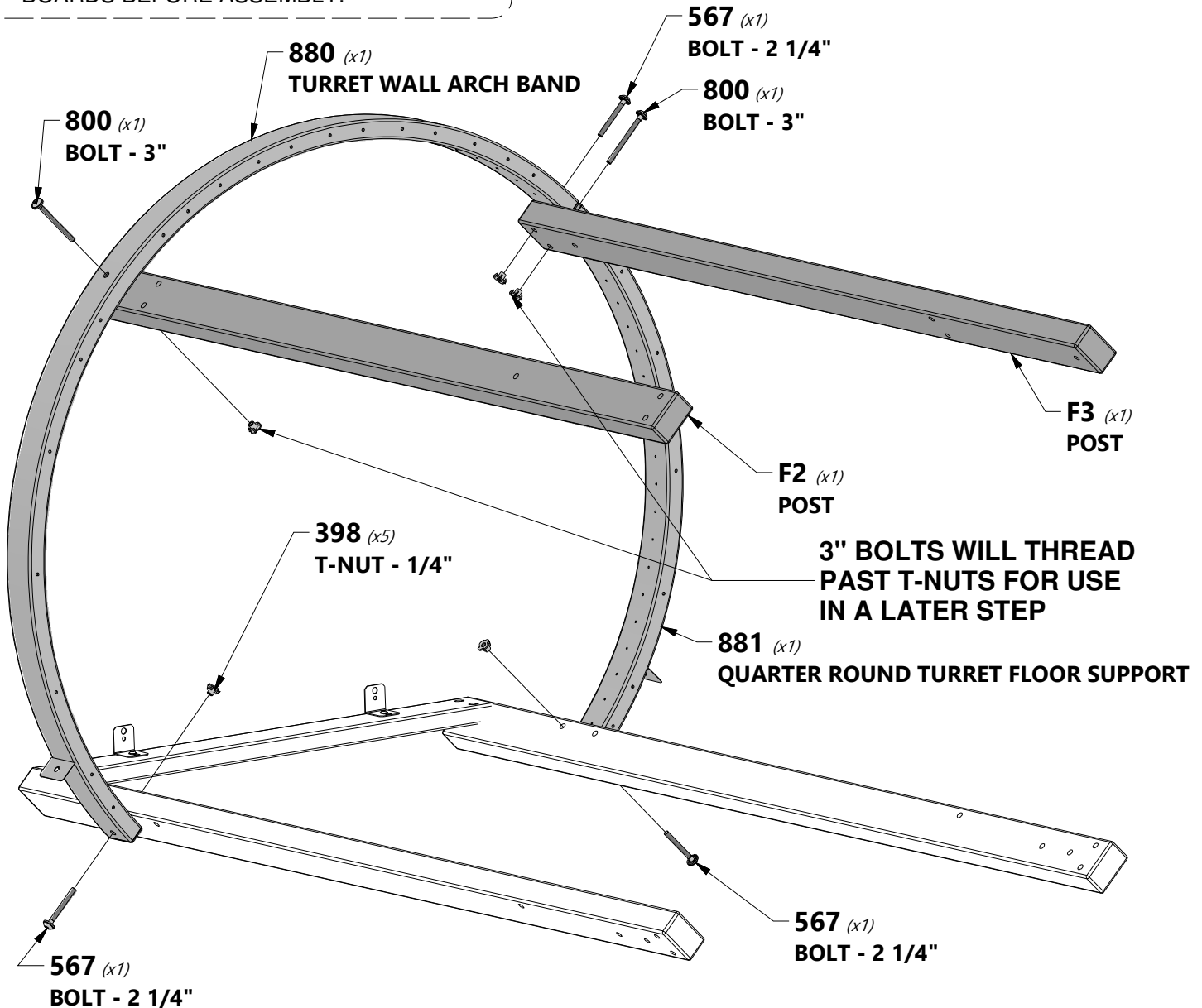



Phase 5

STEP 3

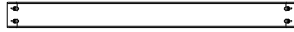

J1 | WALL SUPPORT - W4L08496
(x1) | 1"x2 3/8"x27 1/8" (24x60x688)



H100200 | SCREW PFH BLK
(x4) | 8x1-1/2

200 (x4)
SCREW - 1 1/2"

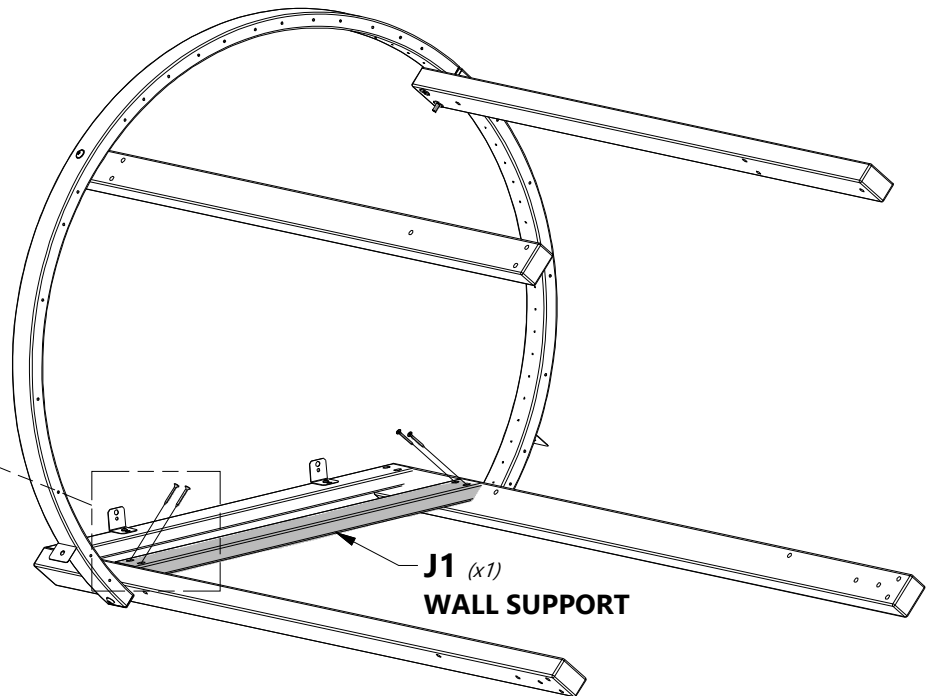
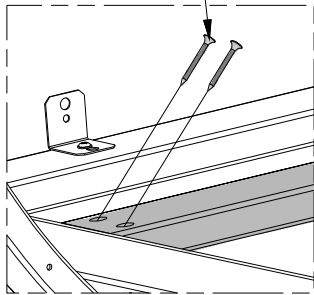

5 in
[124 mm]

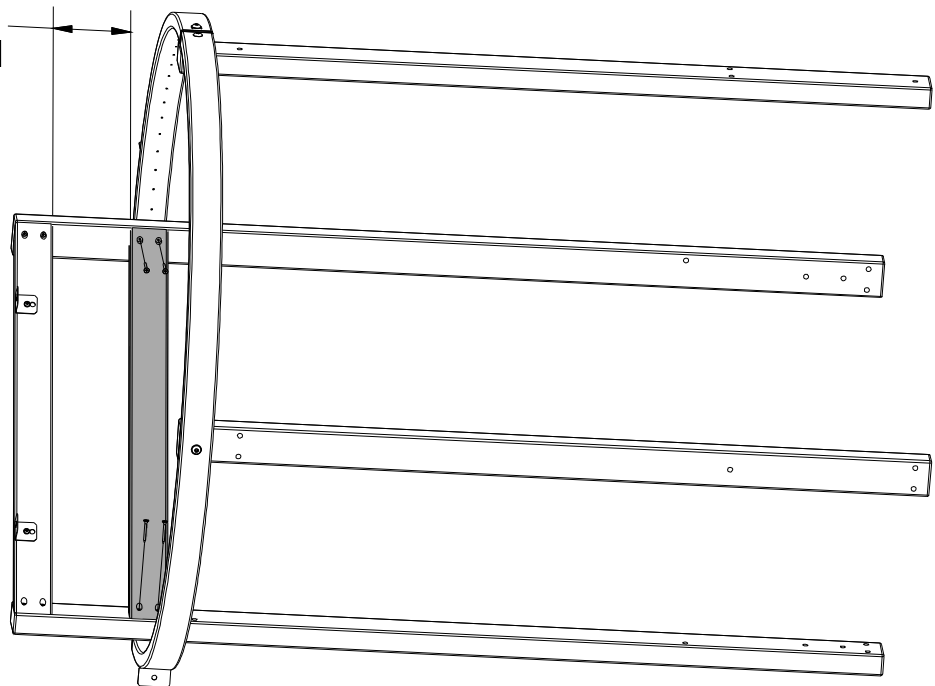

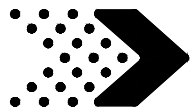

Phase 5

STEP 4

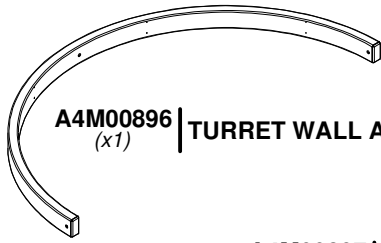

A4M00896 | TURRET WALL ARCH BAND
(x1)



A4M00897 | QUARTER ROUND TURRET FLOOR SUPPORT
(x2)



H100567 | BOLT WH BLK
(x7) | 1/4x2 1/4



H100398 | T-NUT BLK
(x7) | 1/4



TIP:

WE RECOMMEND INSTALLING T-NUTS INTO BOARDS BEFORE ASSEMBLY.

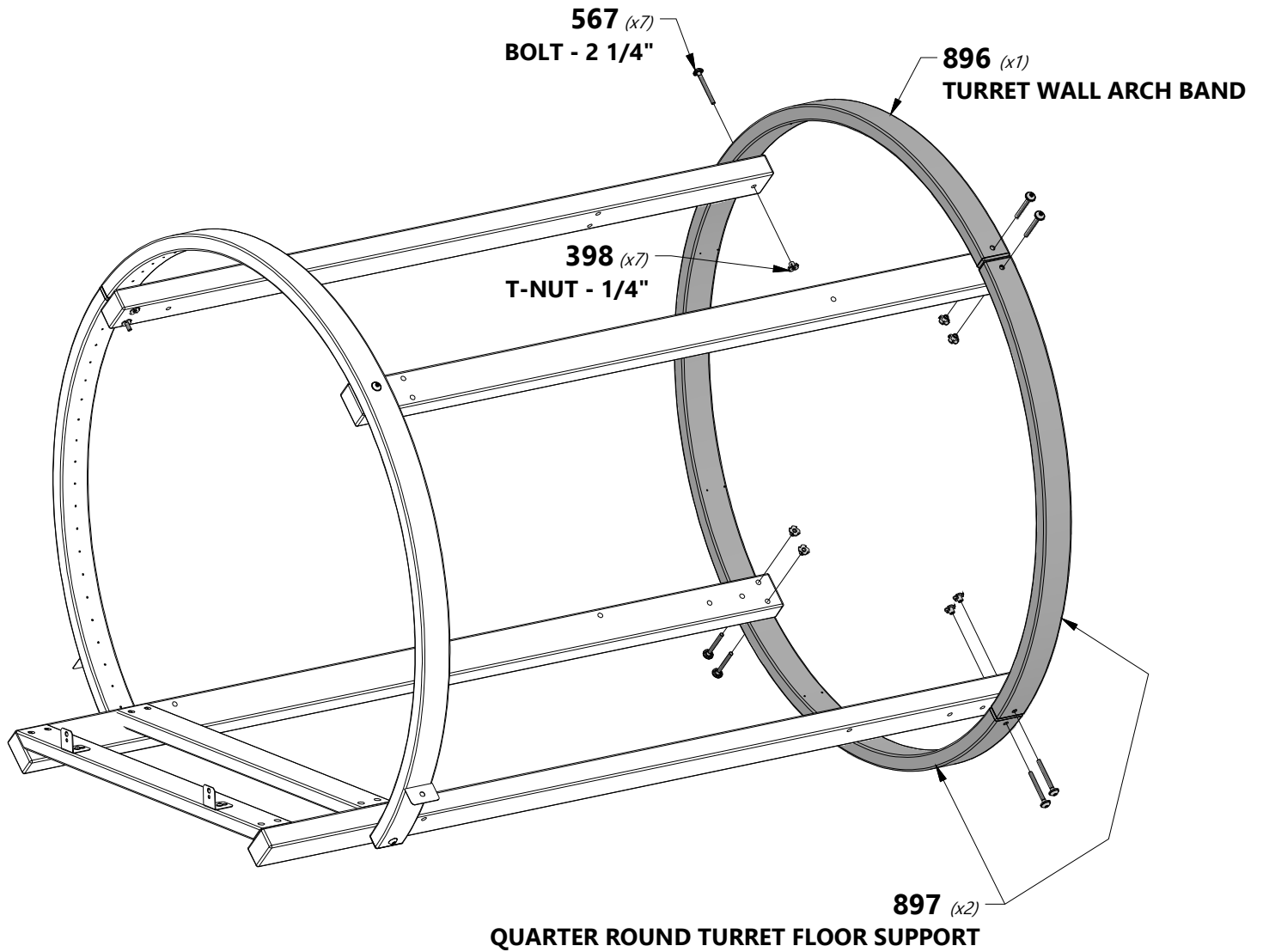

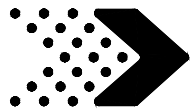

Phase 5

STEP 5

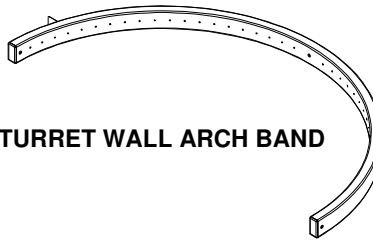

A4M00907 | TURRET WALL ARCH BAND
(x1)



A4M00883 | QUARTER ROUND TURRET FLOOR SUPPORT
(x1)



H100567 | BOLT WH BLK
(x5) | 1/4x2 1/4



H100398 | T-NUT BLK
(x5) | 1/4



TIP:
WE RECOMMEND INSTALLING T-NUTS
INTO BOARDS BEFORE ASSEMBLY.

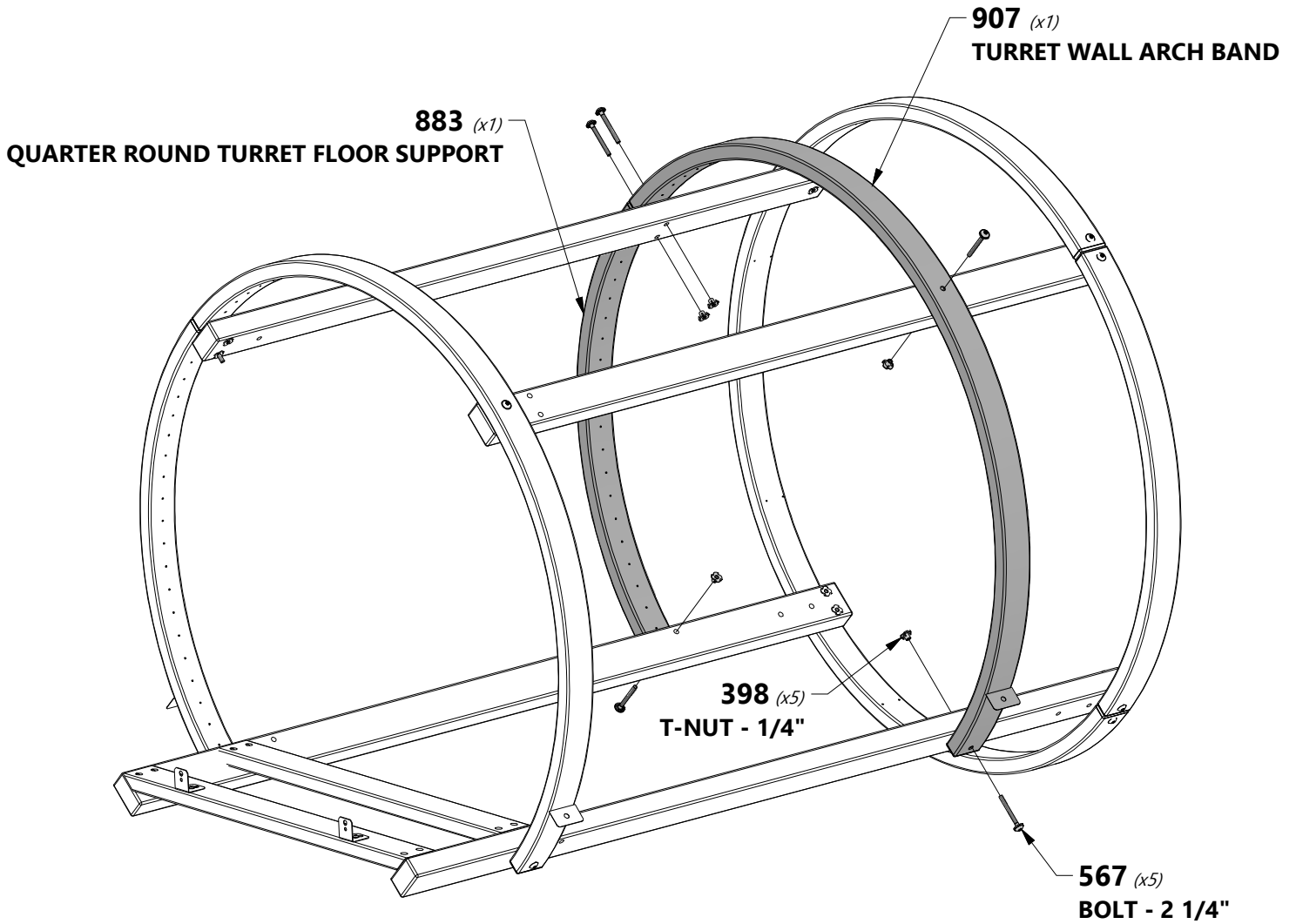

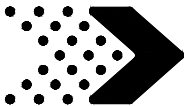

Phase 5

STEP 6

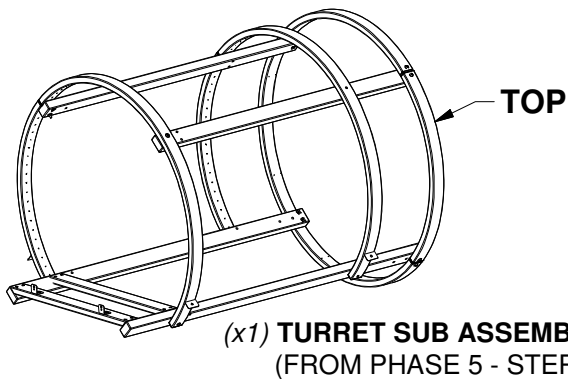

TIP:
WE RECOMMEND INSTALLING T-NUTS INTO BOARDS BEFORE ASSEMBLY.

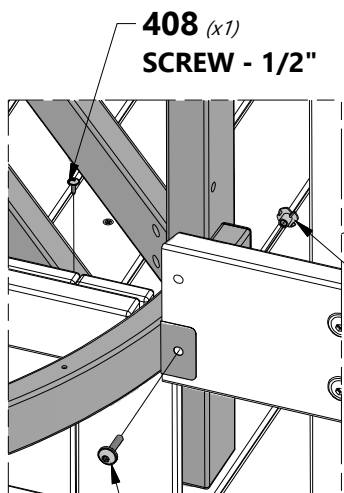
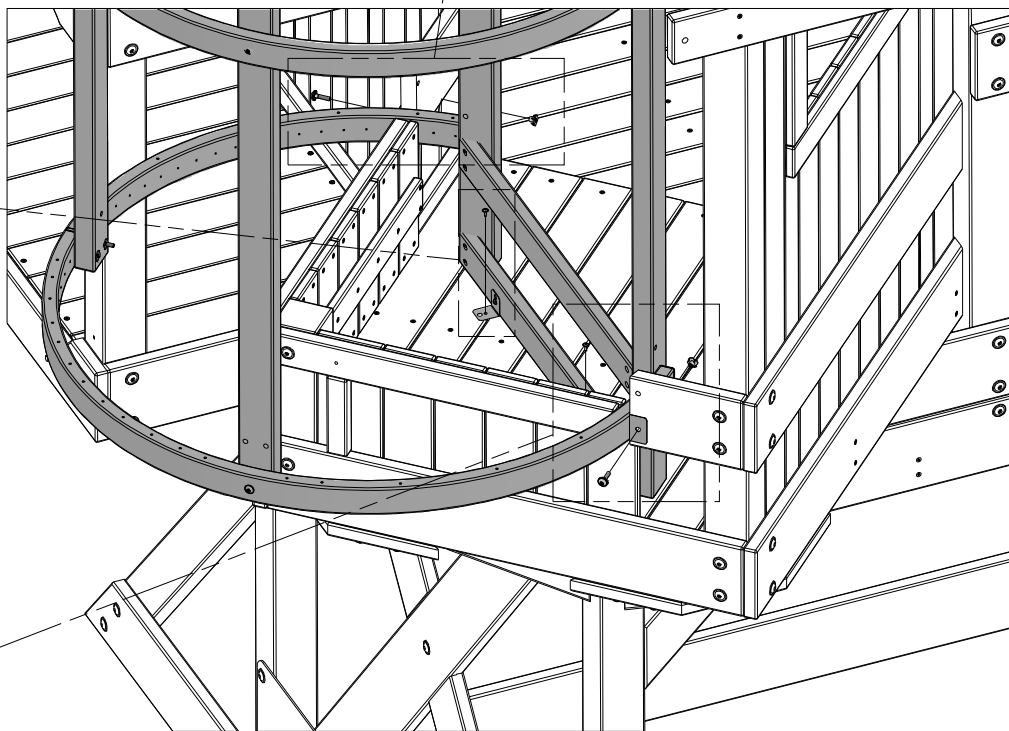
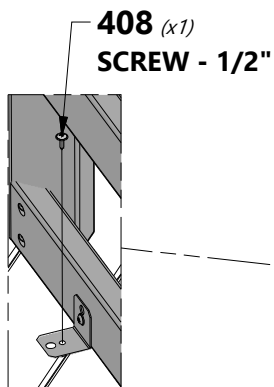
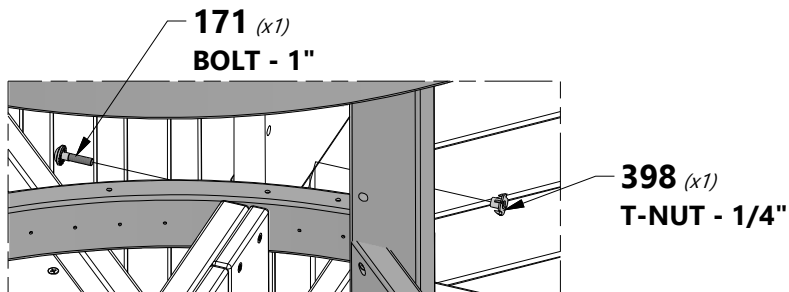

398 (x1)
T-NUT - 1/4"

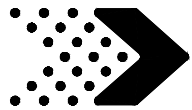

Phase 5

STEP 7



A4M01012 | METAL ANGLE BRACE
(x2)



H100460 | LAG SCREW WH BLK
(x4) | 1/4x1



H100630 | WASHER FLAT BLK
(x2) | 8x19



H100653 | NUT LOCK BLK
(x2) | 1/4

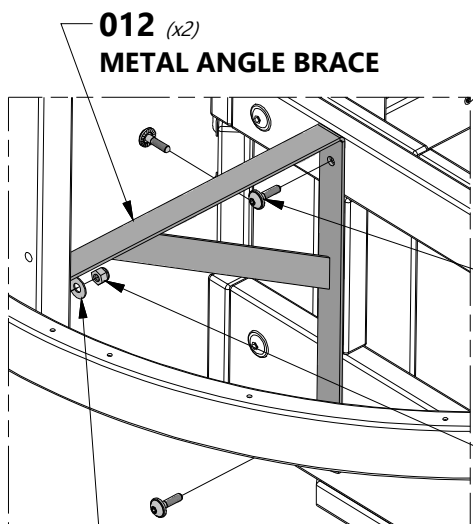
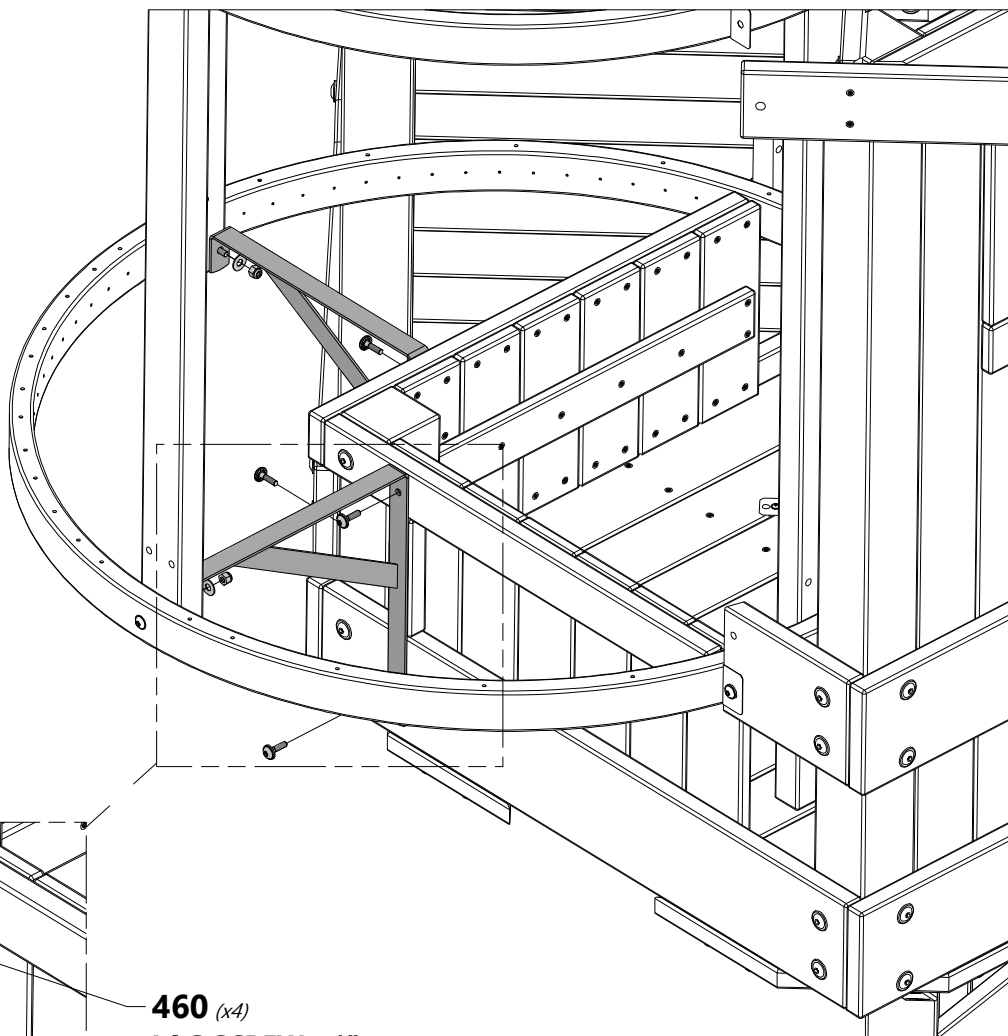

012 (x2)
METAL ANGLE BRACE

460 (x4)
LAG SCREW - 1"

653 (x2)
NUT - 1/4"

630 (x2)
WASHER - 8x19



Phase 5

STEP 8



L8 | WALL PICKET - W4L08046
(x4) | 5/8"x4 3/8"x9 5/8" (16x112x244)



O2 | WALL PICKET - W4L08047
(x2) | 5/8"x3"x9 5/8" (16x75x244)



H100387 | SCREW PFH BLK
(x24) | 8x1-1/4

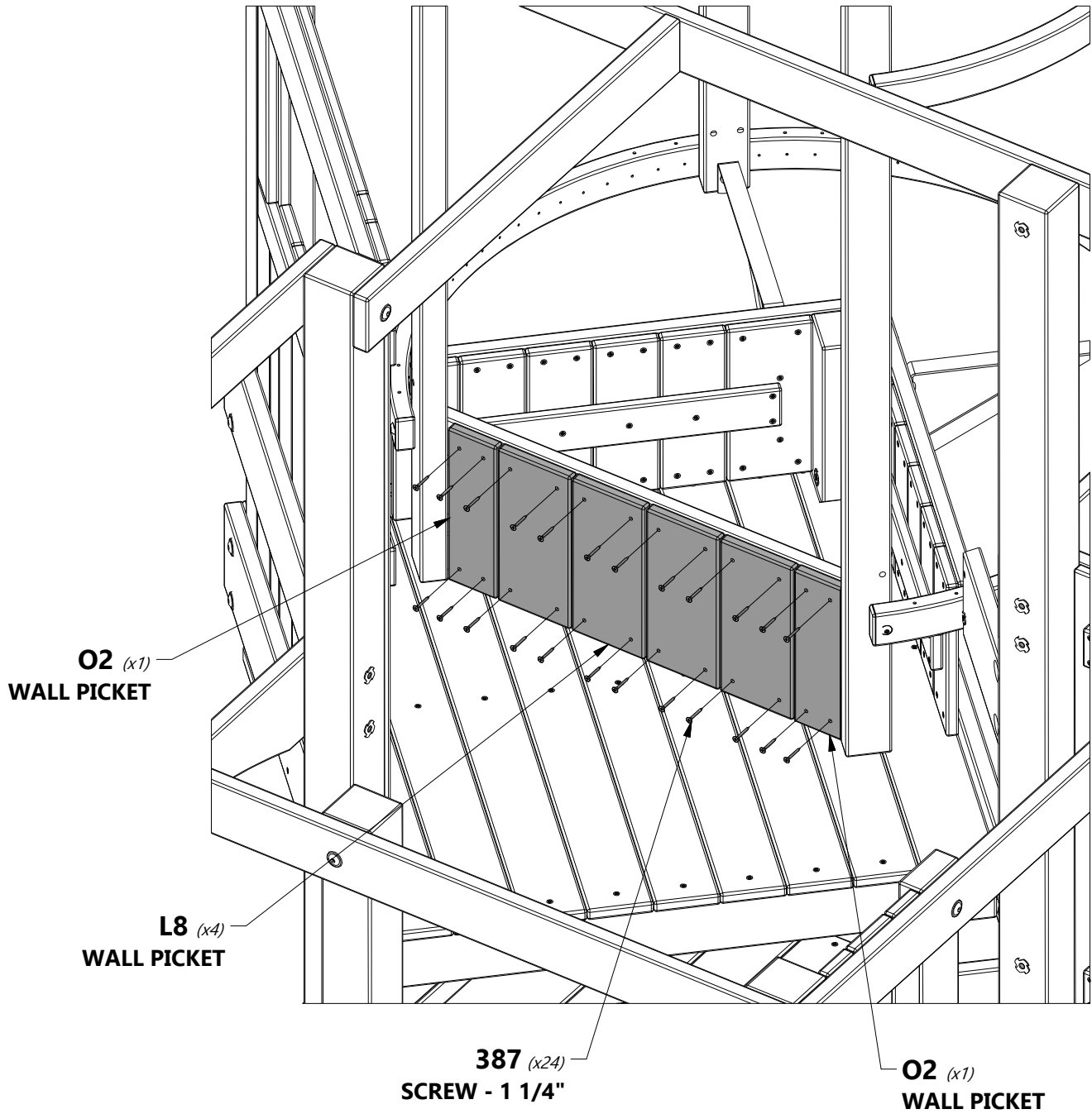

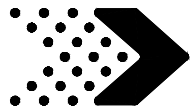

Phase 5

STEP 9

M7 | FLOOR BOARD - W4L08038
(x2) | 5/8"x2 1/2"x19 3/8" (16x62x493)

L4 | FLOOR BOARD - W4L12917
(x2) | 5/8"x4 3/8"x33 1/2" (16x112x852)

H100200 | SCREW PFH BLK
(x20) | 8x1-1/2"

L5 | FLOOR BOARD - W4L12918
(x2) | 5/8"x4 3/8"x31 7/8" (16x112x811)



H100746 | SCREW PWH SD
(x26) | 10x1 1/4"

L1 | FLOOR BOARD - W4L12916
(x2) | 5/8"x4 3/8"x34" (16x112x865)

L6 | FLOOR BOARD - W4L12919
(x2) | 5/8"x4 3/8"x27" (16x112x687)

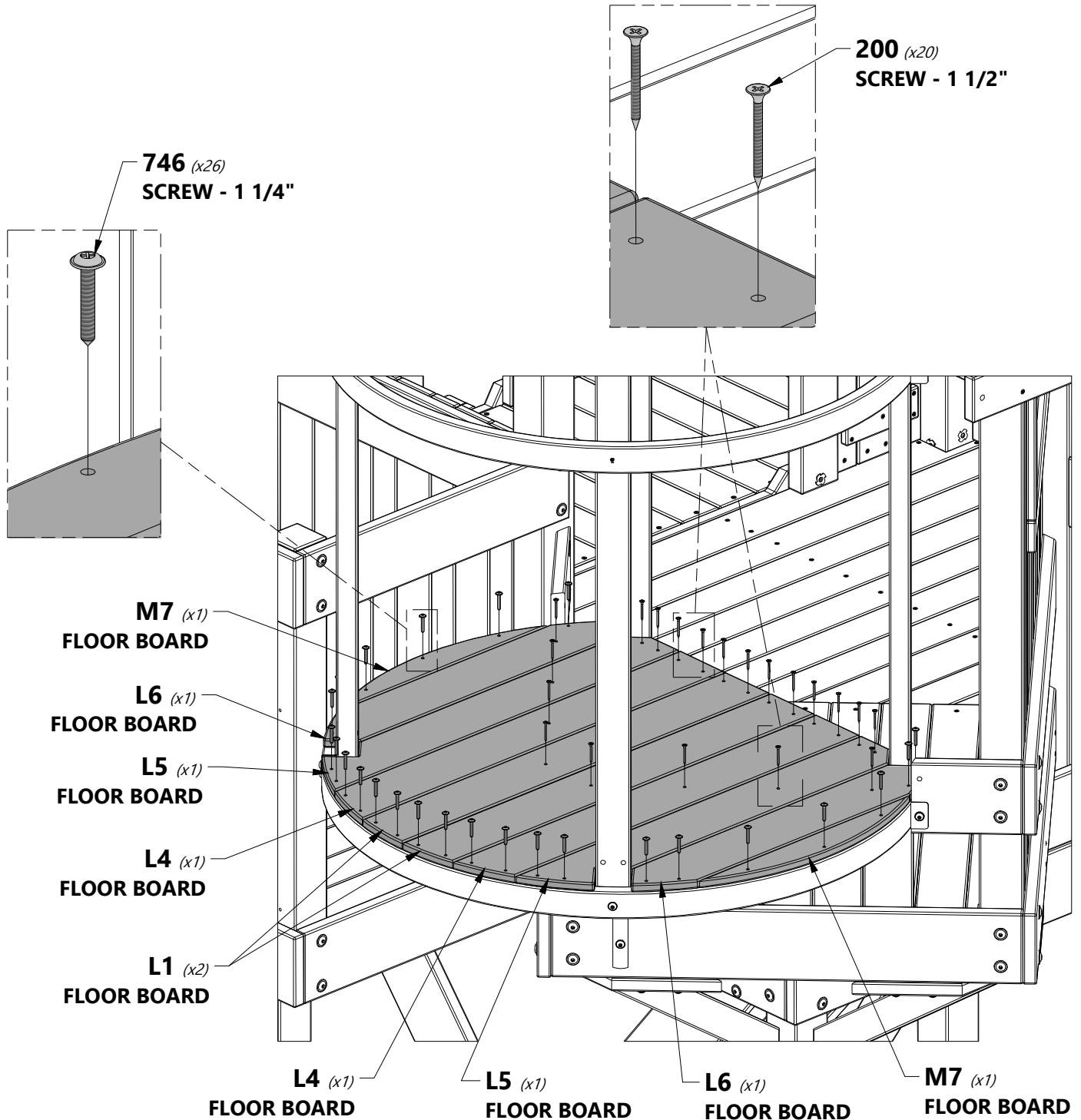

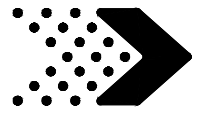

Phase 5

STEP 10

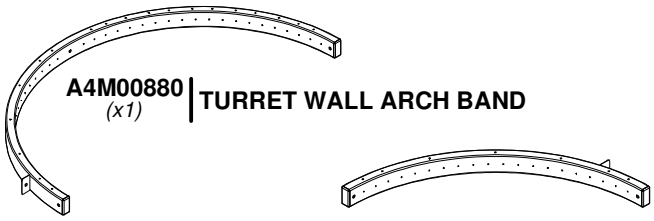

A4M00880 | TURRET WALL ARCH BAND
(x1)

A4M00881 | QUARTER ROUND TURRET FLOOR SUPPORT
(x1)

H100567 | BOLT WH BLK
(x5) | 1/4x2 1/4

H100398 | T-NUT BLK
(x7) | 1/4

H100171 | BOLT WH BLK
(x2) | 1/4x1



TIP:
WE RECOMMEND INSTALLING T-NUTS INTO BOARDS BEFORE ASSEMBLY.

567 (x3)
BOLT - 2 1/4"

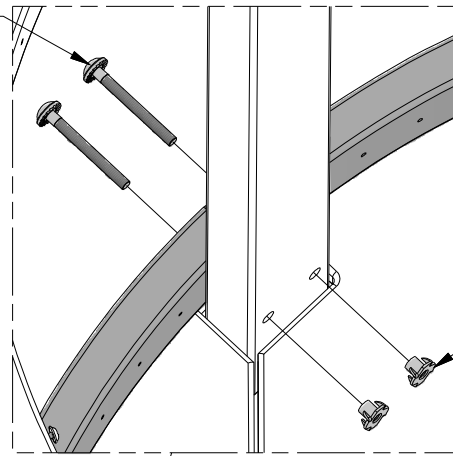

398 (x3)
T-NUT - 1/4"

880 (x1)
TURRET WALL ARCH BAND

881 (x1)
QUARTER ROUND TURRET FLOOR SUPPORT

171 (x2)
BOLT - 1"

398 (x2)
T-NUT - 1/4"

398 (x2)
T-NUT - 1/4"

567 (x2)
BOLT - 2 1/4"

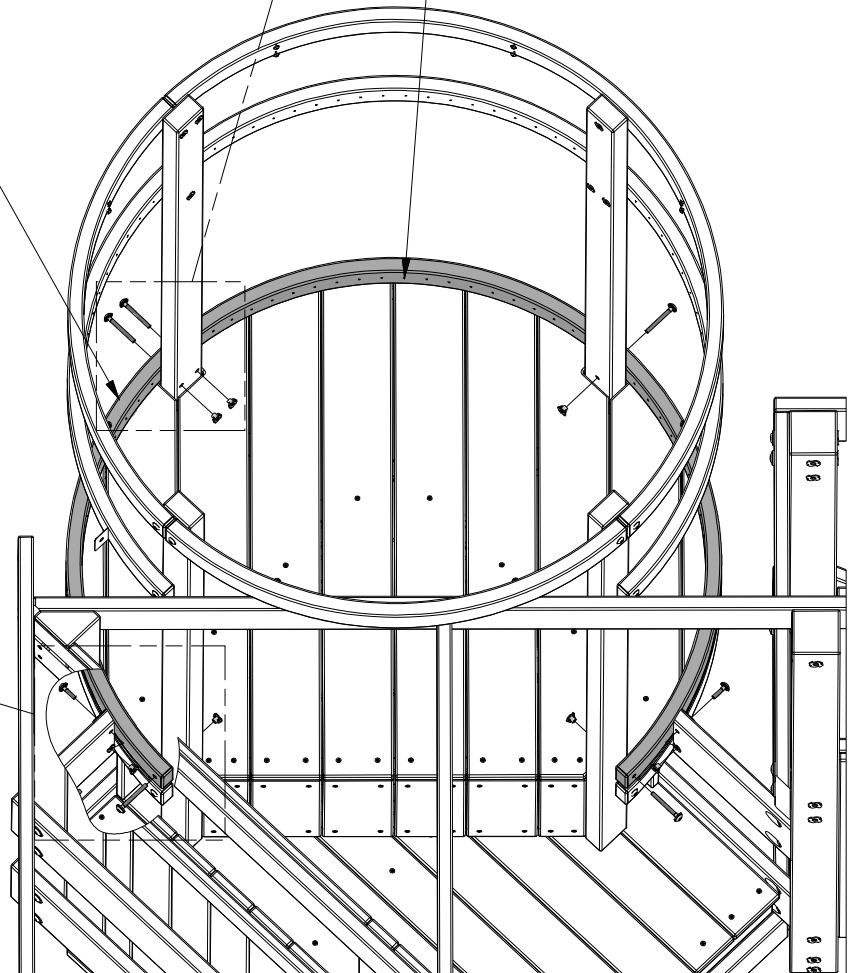

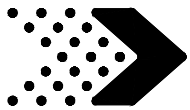

O1 | WALL PICKET - W4L08506
(x60) | 5/8"x1 3/8"x32 7/8" (16x34x835)



H100746 | SCREW PWH SD
(x120) | 10x1 1/4

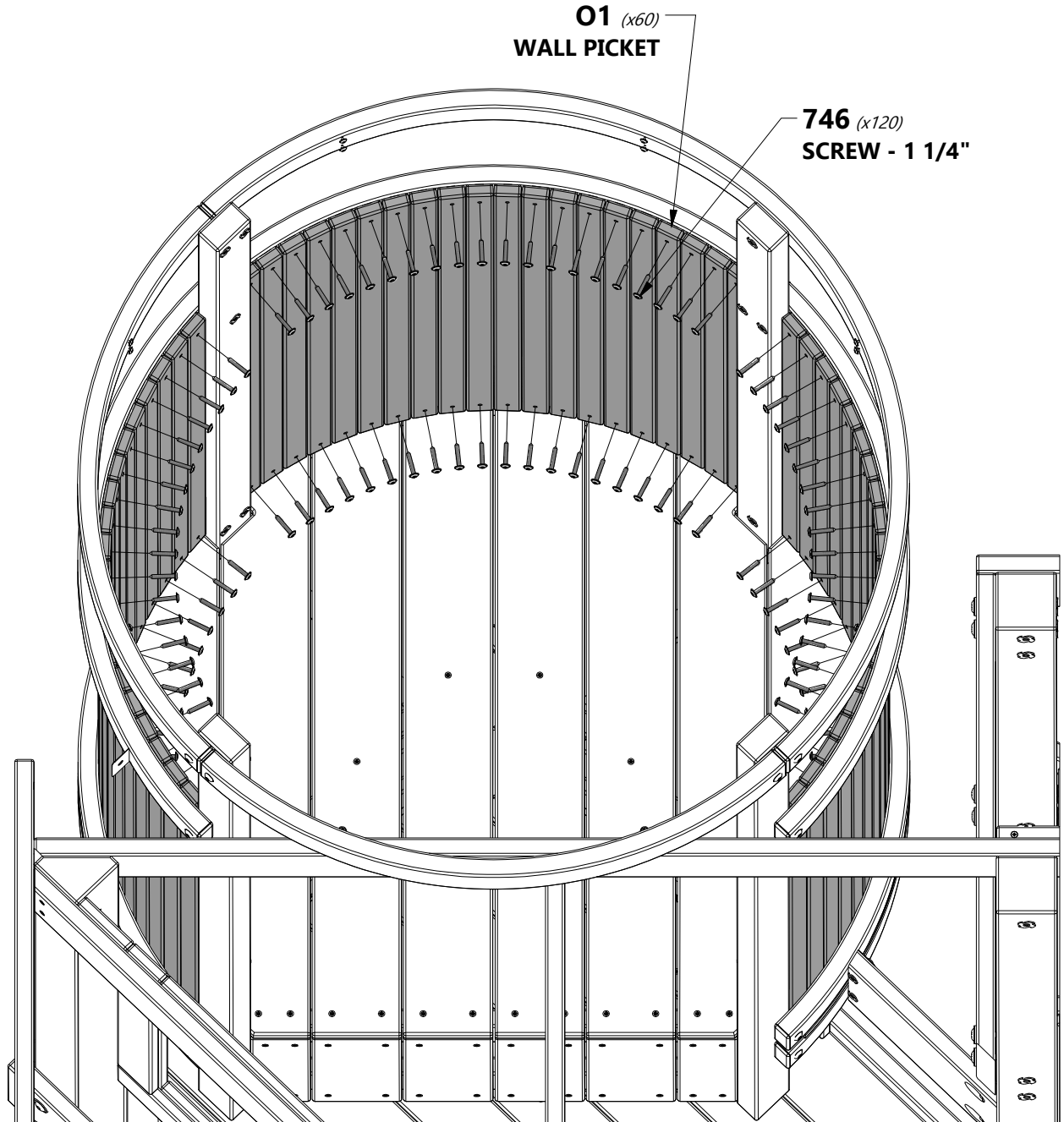

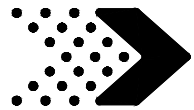

Phase 5

STEP 12



G19 | WALL SUPPORT - W4L08560
(x1) | 1"x5 1/4"x8 5/8" (24x134x218)



H100415 | BOLT WH BLK
(x1) | 5/16x3 3/4



H100379 | T-NUT BLK
(x1) | 5/16



H100387 | SCREW PFH BLK
(x4) | 8x1-1/4



K6 | WALL PICKET - W4L08561
(x1) | 5/8"x5 1/4"x43 1/4" (16x132x1099)



H100171 | BOLT WH BLK
(x1) | 1/4x1



H100398 | T-NUT BLK
(x1) | 1/4



H100198 | WASHER LOCK EXT BLK
(x1) | 8x19



NOTE:

1. ASSEMBLE THE SUB ASSEMBLY FIRST.
2. INSTALL THE T-NUT INTO 'G19' BOARD AND THEN ASSEMBLE 'K6' TO 'G19' BOARD.



TIP:

WE RECOMMEND INSTALLING T-NUTS INTO BOARDS BEFORE ASSEMBLY.

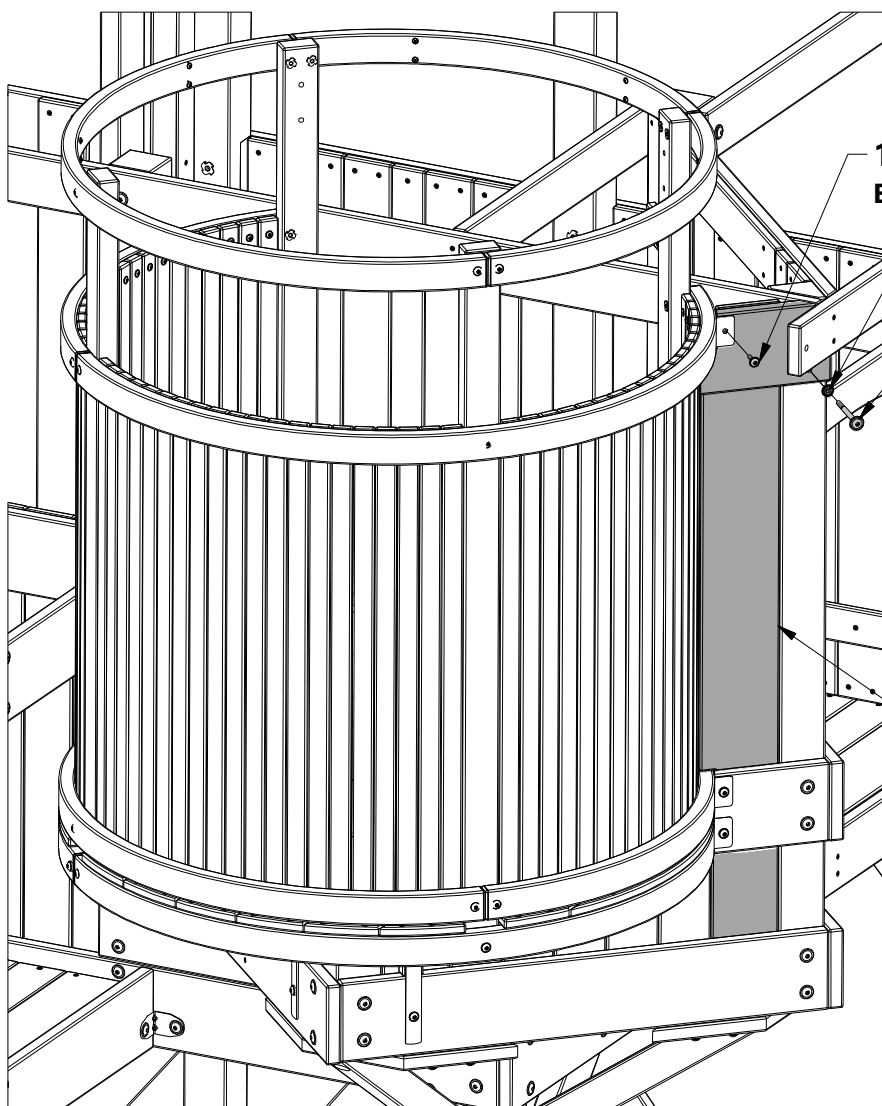
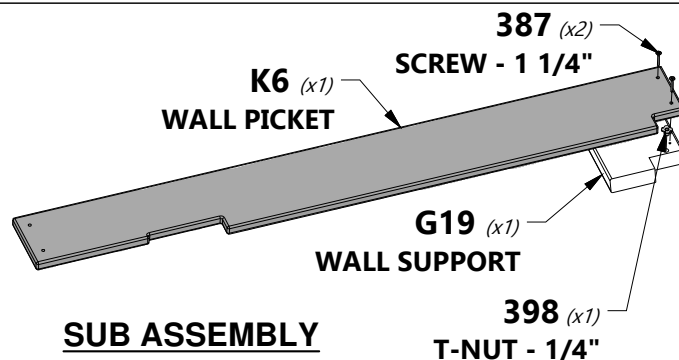

OUTSIDE VIEW

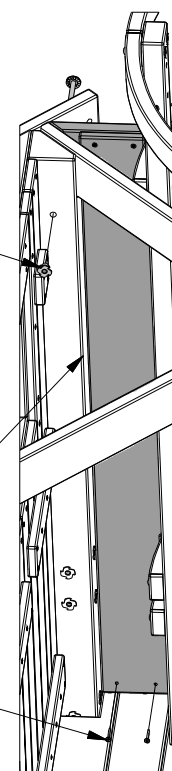

INSIDE VIEW

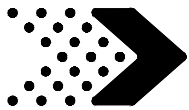

Phase 5

STEP 13

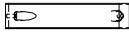

J4 | WALL SUPPORT - W4L08550
(x1) | 1"x2 3/8"x11 5/8" (24x60x295)

H100397 | BOLT WH BLK
(x1) | 1/4x1 1/4

H100405 | WASHER LOCK EXT BLK
(x1) | 6x15

H100198 | WASHER LOCK EXT BLK
(x1) | 8x19

H100400 | WASHER LOCK EXT BLK
(x1) | 8x15

H100471 | LAG SCREW WH BLK
(x1) | 5/16x1 1/2

H100404 | NUT BARREL WH BLK
(x1) | 1/4x5/8

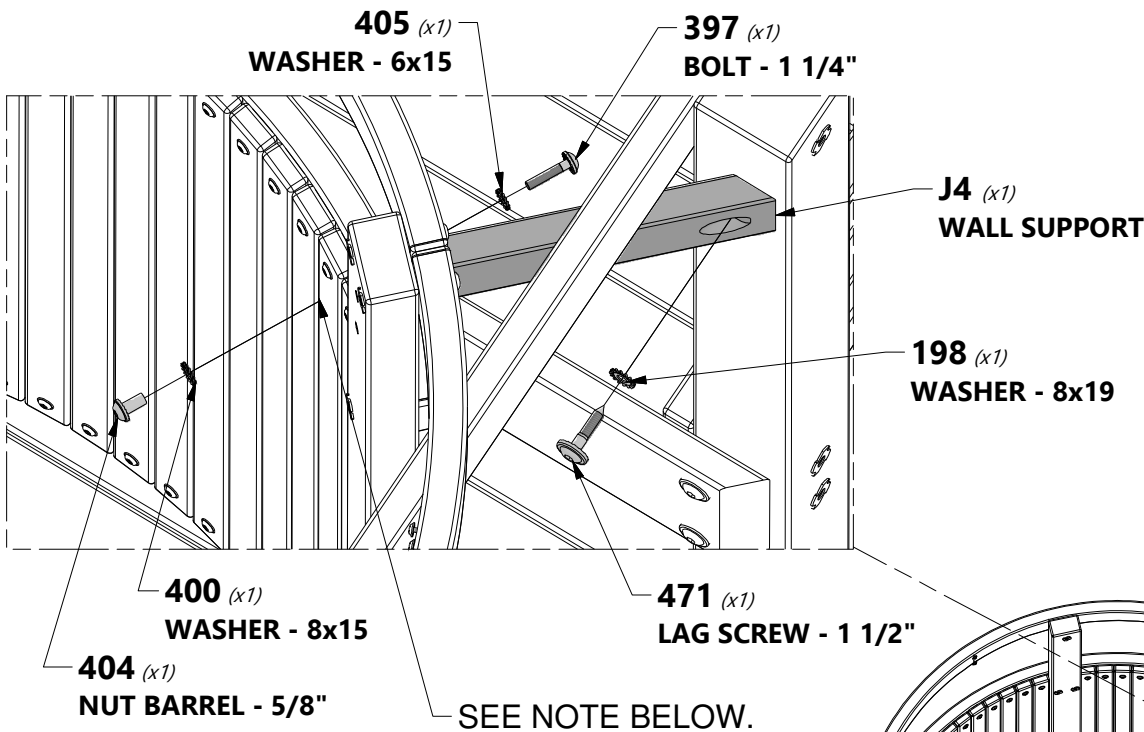

NOTE:

1. USE THE 'J4' SUPPORT HOLE AS A TEMPLATE AND MARK WHERE THE SUPPORT MEETS THE TURRET.
2. USING A 5/16" OR 8 MM DRILL BIT, DRILL A THROUGH HOLE INTO THE TURRET.
3. ATTACH THE 'J4' SUPPORT TO THE TURRET USING HARDWARE SHOWN.

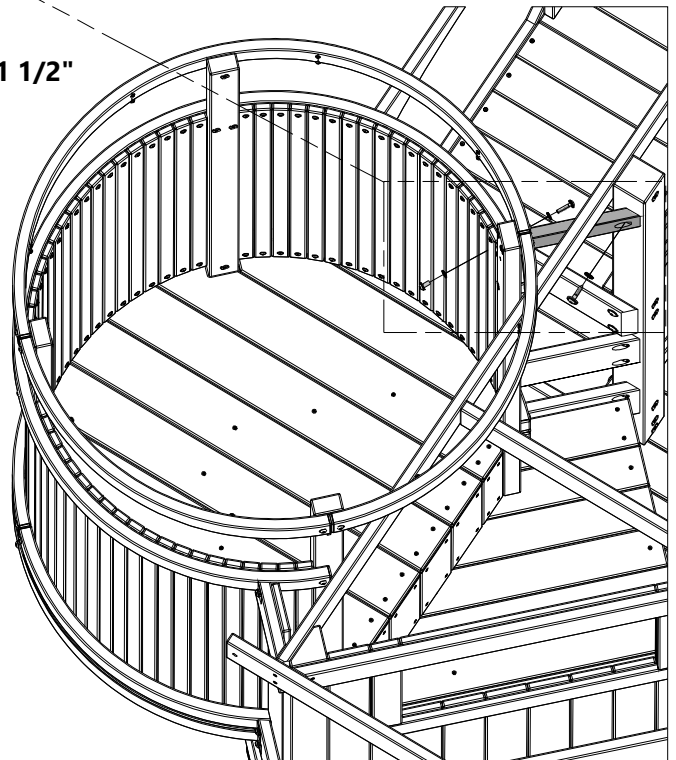

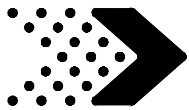

Phase 5

STEP 14

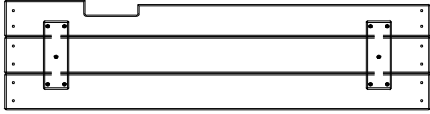

WP5 | WALL PANEL - W2A02907
(x1) | 1 1/4"x9 13/16"x39 7/8" (32x250x1013)



O3 | WALL PICKET - W4L08512
(x1) | 5/8"x1 3/8"x39 7/8" (16x34x1013)



H100387 | SCREW PFH BLK
(x14) | 8x1-1/4

WP5 (x1)
WALL PANEL

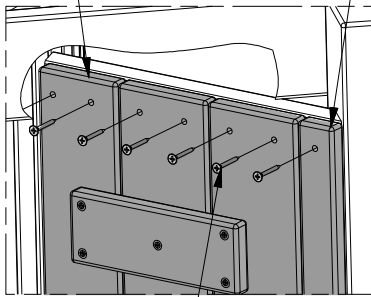

387 (x14)
SCREW - 1 1/4"

O3 (x1)
WALL PICKET

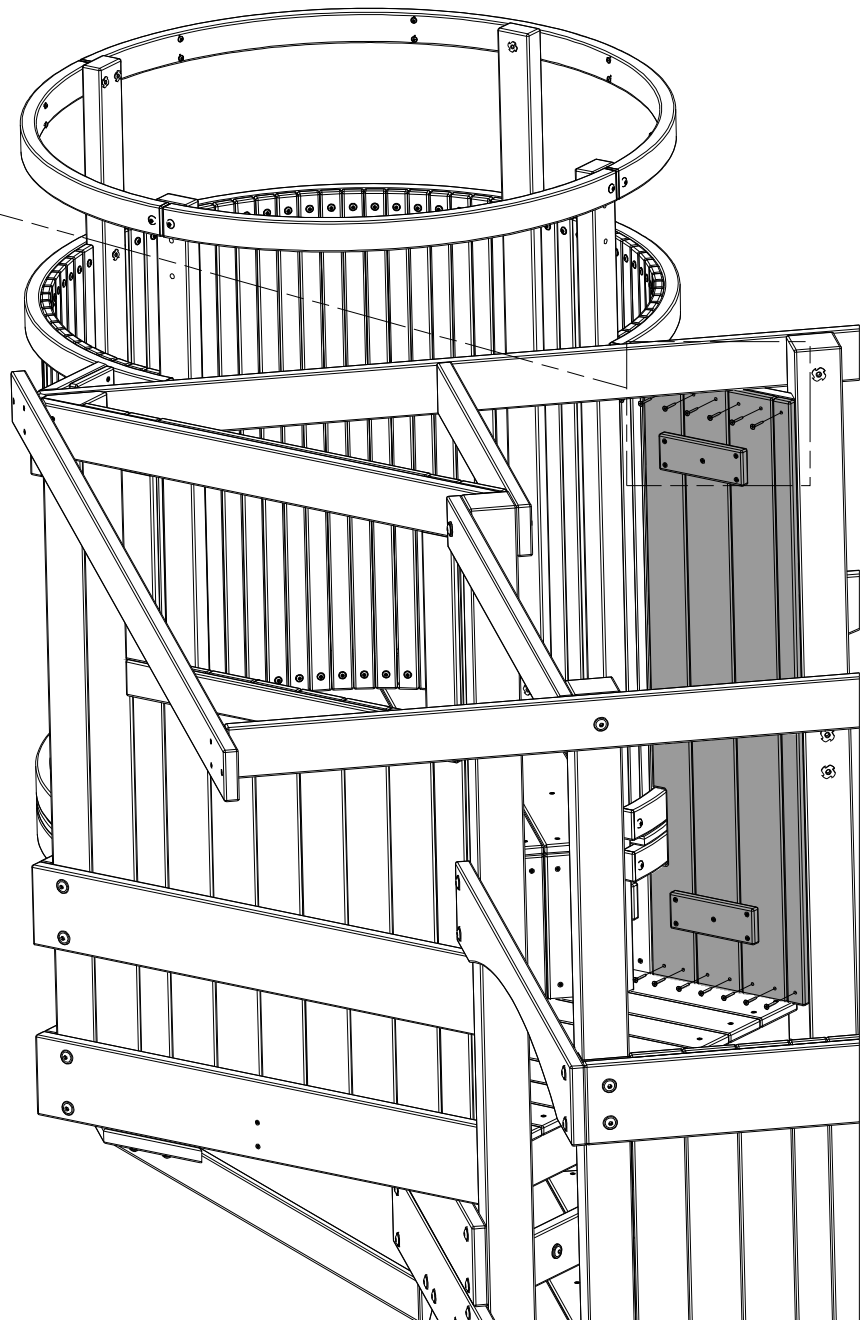

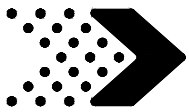

Phase 5

STEP 15



M38 | TURRET FILLER BOARD - W4L11445
(x2) | 5/8"x3 3/8"x5 3/4" (16x86x146)



H100488 | BOLT WH BLK
(x4) | 1/4x2



H100405 | WASHER LOCK EXT BLK
(x4) | 6x15



H100398 | T-NUT BLK
(x4) | 1/4



TIP:

WE RECOMMEND INSTALLING T-NUTS INTO BOARDS BEFORE ASSEMBLY.

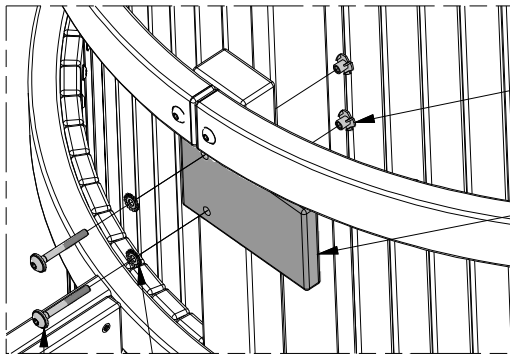

398 (x4)
T-NUT - 1/4"

M38 (x2)
TURRET FILLER BOARD

488 (x4)
BOLT - 2"

405 (x4)
WASHER - 6x15

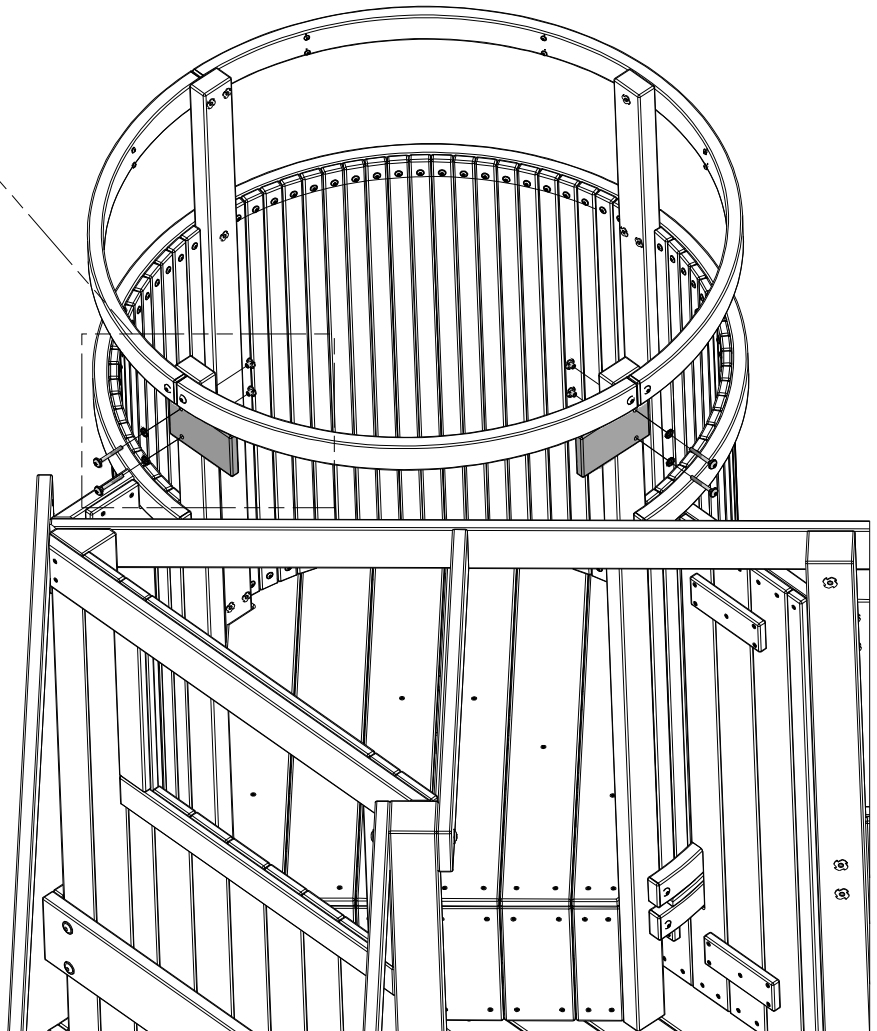

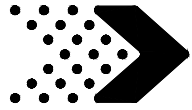

Phase 5

STEP 16

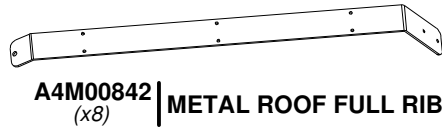

A4M00842 (x8) | METAL ROOF FULL RIB

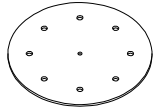

A4M00844 (x1) | ROUND ROOF RIB CONNECTOR PLATE



H100489 (x8) | BOLT PTH BLK
1/4x3/4



H100630 (x8) | WASHER FLAT BLK
8x19



H100653 (x8) | NUT LOCK BLK
1/4



H100392 (x16) | SCREW PWH BLK
8x3/4



NOTE:
ASSEMBLE THE SUB ASSEMBLY FIRST.

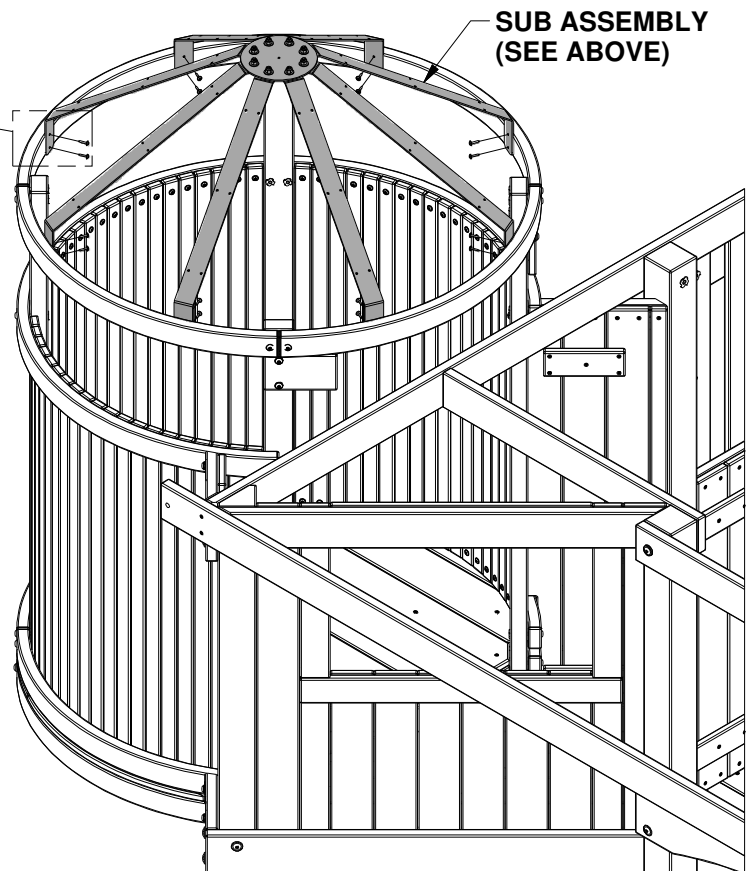
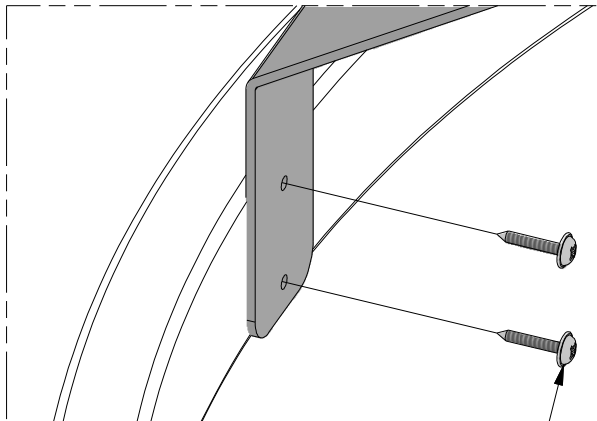
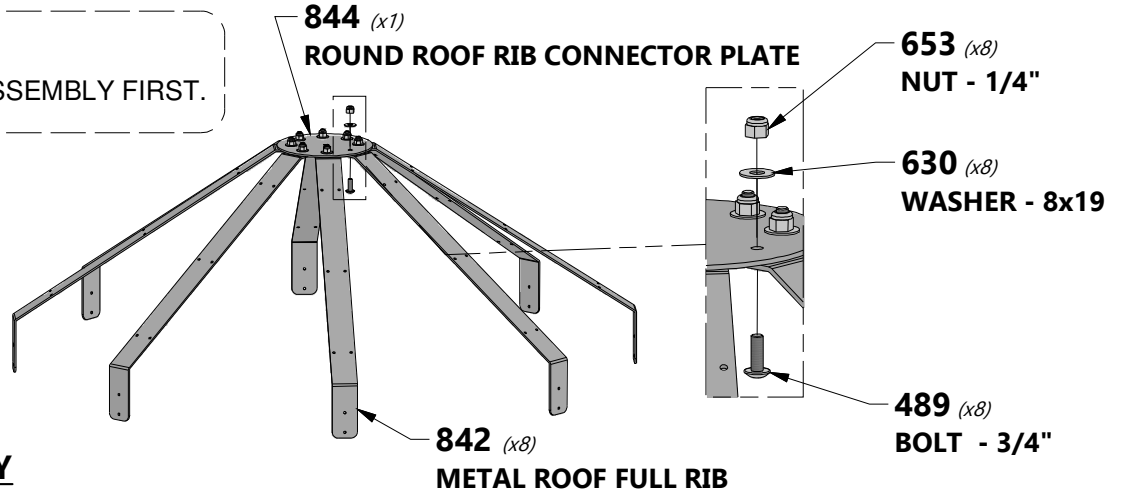

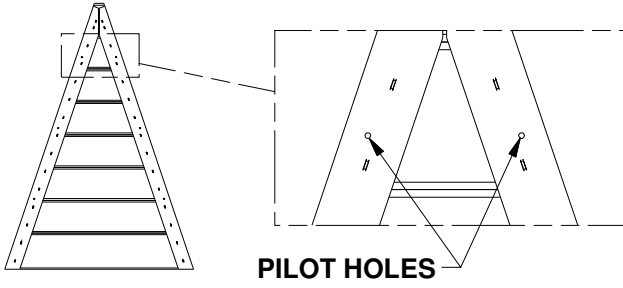

H100392 | SCREW PWH BLK
(x48) | 8x3/4

RP07 | ROOF PANEL - W2A02189
(x8) | 13/16"x24 7/8"x17 11/16" (21x632x450)

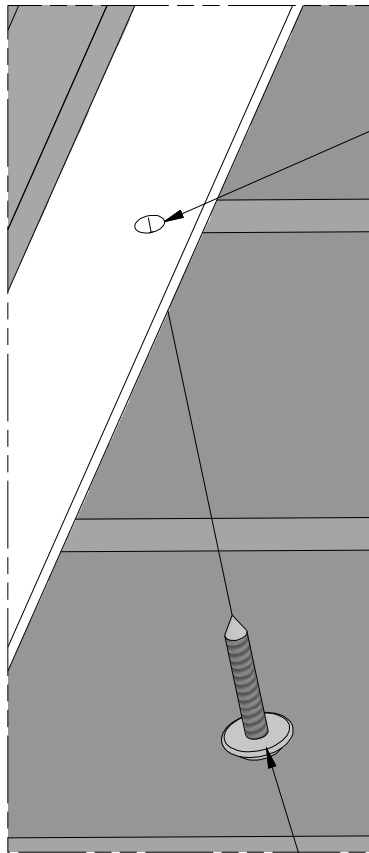

SCREW INTO
PILOT HOLES
LOCATED IN
ROOF PANELS.

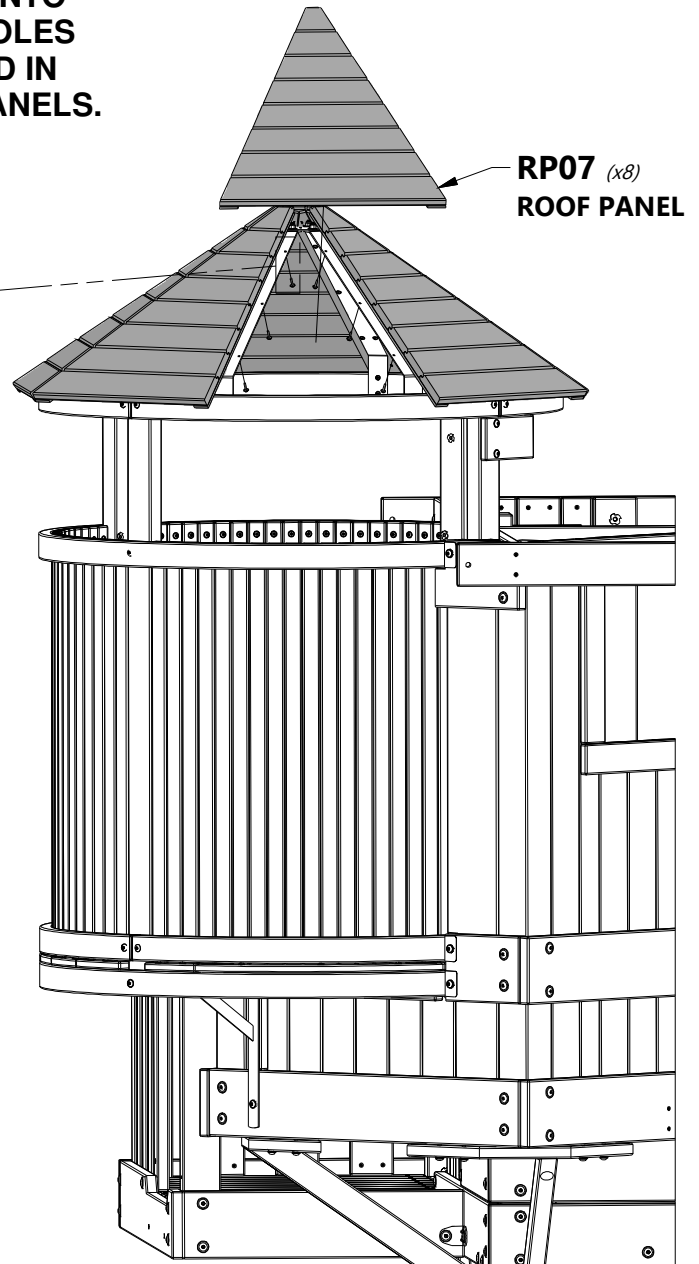

392 (x48)
SCREW - 3/4"

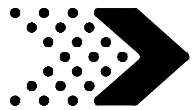

Phase 5

STEP 18

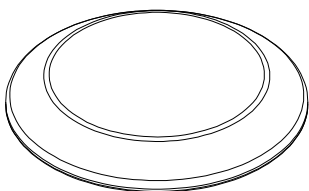

A6P00239
(x1) | **ROUND ROOF PLASTIC CAP**



H100736 | **SCREW PWH SD**
(x1) | **8x1 5/8**



NOTE:
DO NOT OVER-TIGHTEN SCREW.



2 PEOPLE REQUIRED

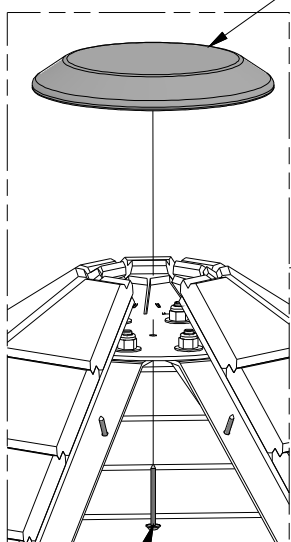

239 *(x1)*
ROUND ROOF PLASTIC CAP

736 *(x1)*
SCREW - 1 5/8"

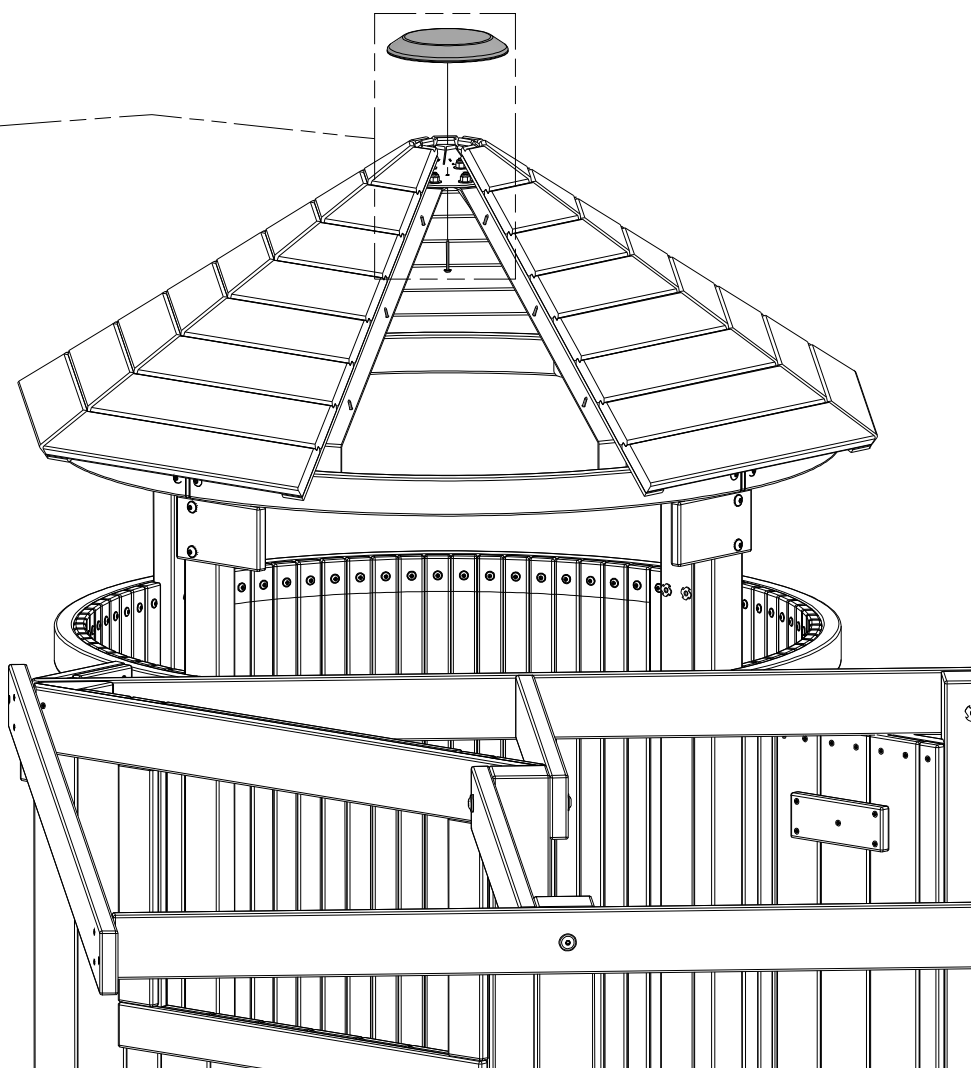



Phase 5

STEP 19



M23 | WALL PICKET - W4L08544
(x3) | 5/8"x3 3/8"x29 7/8" (16x86x759)



H100387 | SCREW PFH BLK
(x12) | 8x1-1/4

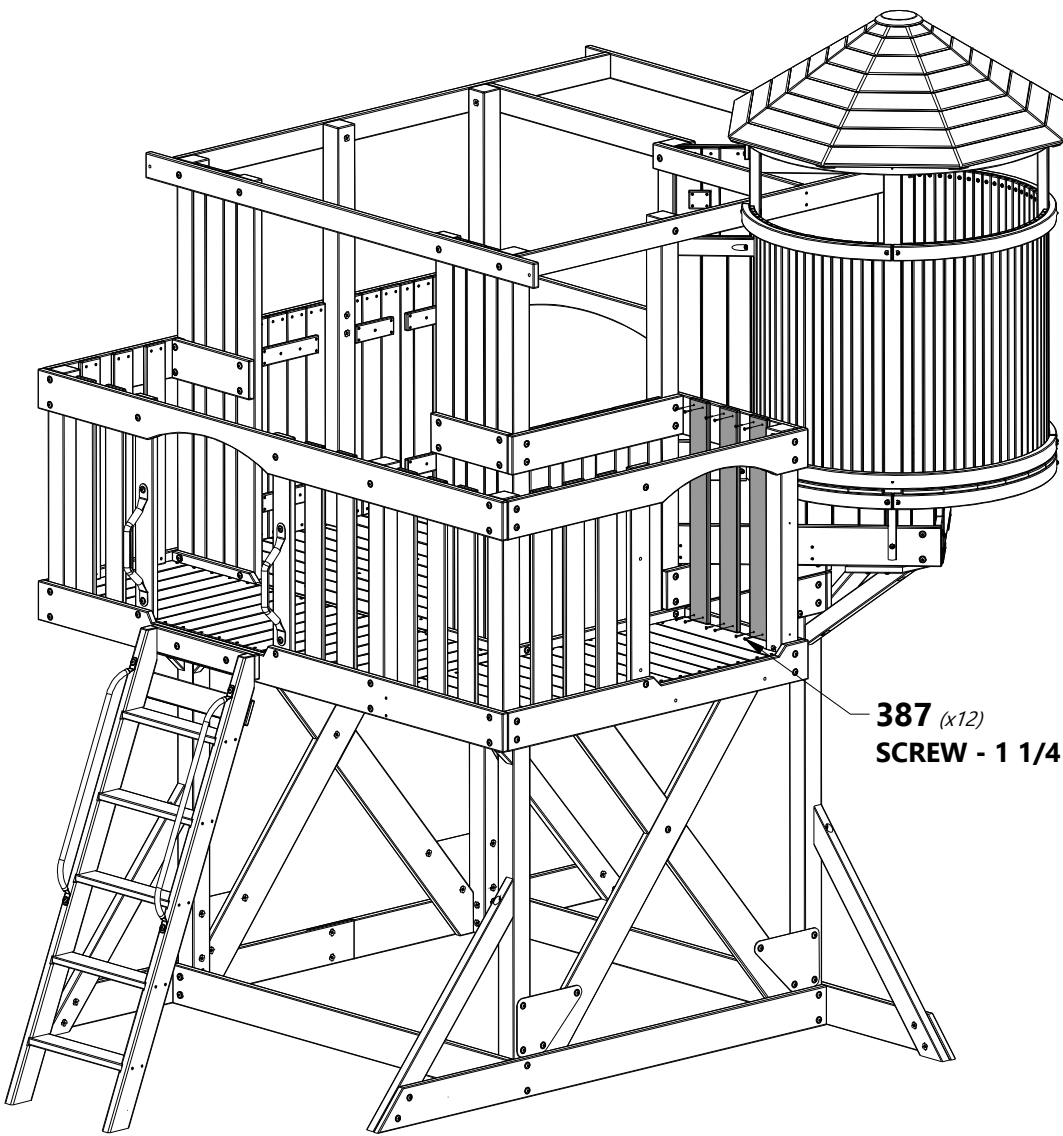

387 (x12)
SCREW - 1 1/4"

2 3/8 in [60 mm]
(3 SPCS)

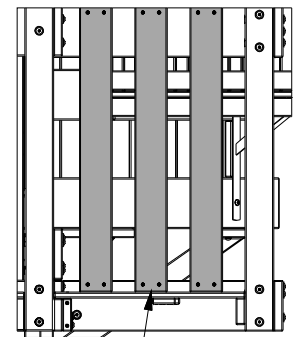

M23 (x3)
WALL PICKET

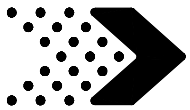

Phase 6

STEP 1

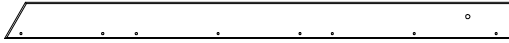

H15 | RAFTER - W4L08526
(x2) | 1"x3 3/8"x47 5/8" (24x86x1209)



H100378 | BOLT WH BLK
(x2) | 5/16x1 3/4



H100379 | T-NUT BLK
(x2) | 5/16



H100198 | WASHER LOCK EXT BLK
(x2) | 8x19



TIP:

WE RECOMMEND INSTALLING T-NUTS INTO BOARDS BEFORE ASSEMBLY.

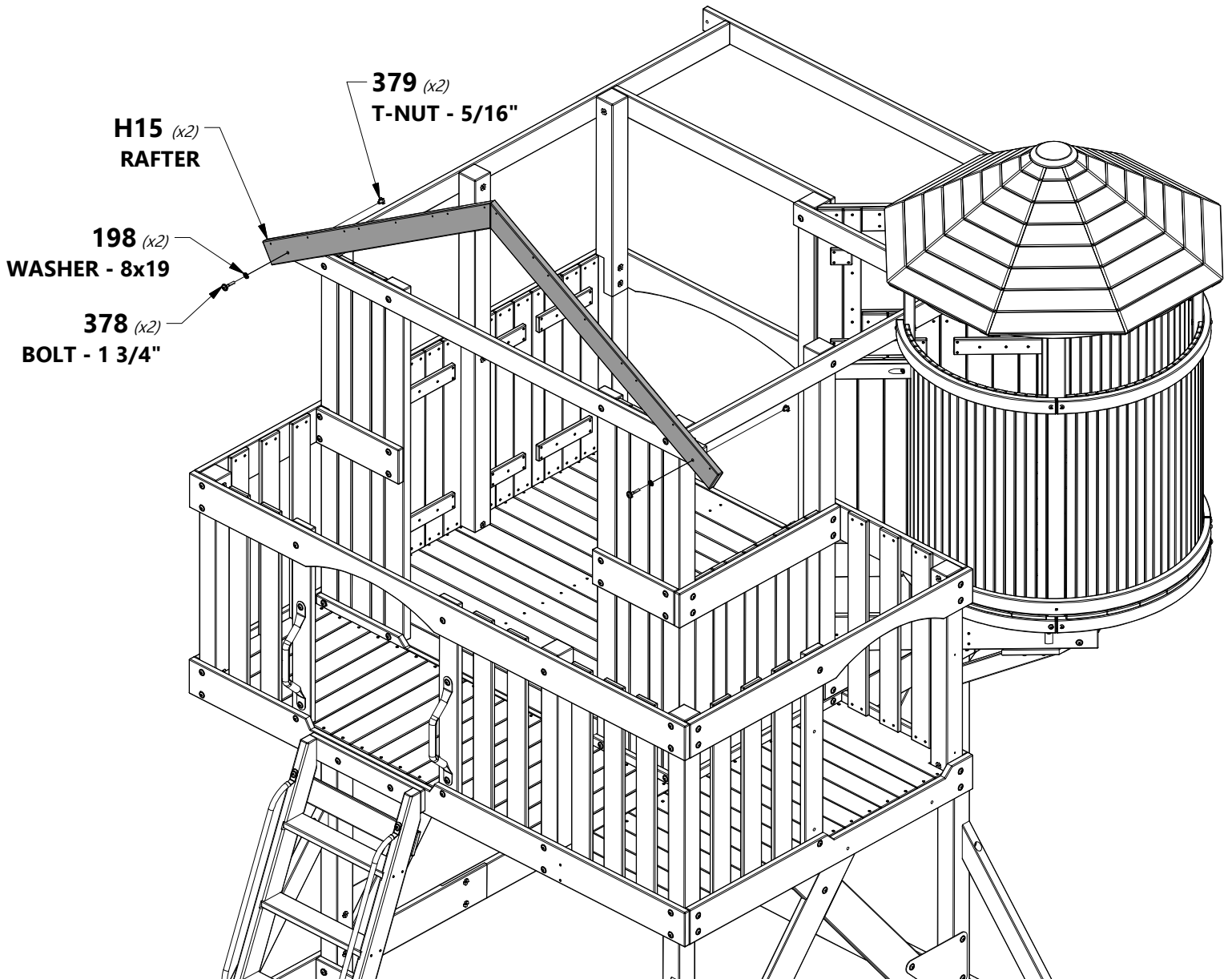

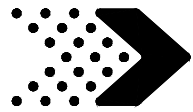

Phase 6

STEP 2

M16 | WALL BOARD - W4L08530
(x1) 5/8"x3 3/8"x34 1/8" (16x86x867)

M17 | WALL BOARD - W4L08531
(x1) 5/8"x3 3/8"x22 3/8" (16x86x567)

M18 | WALL BOARD - W4L08532
(x1) 5/8"x3"x10 1/2" (16x77x268)

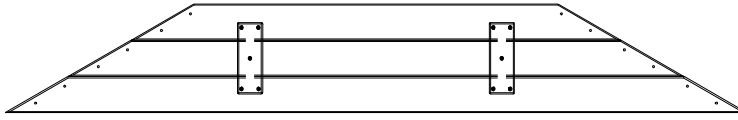

GP1 | GABLE PANEL - W2A02914
(x1) 1 1/4"x69 1/2"x10 3/16" (32x1766x259)



H100387 | SCREW PFH BLK
(x24) 8x1-1/4

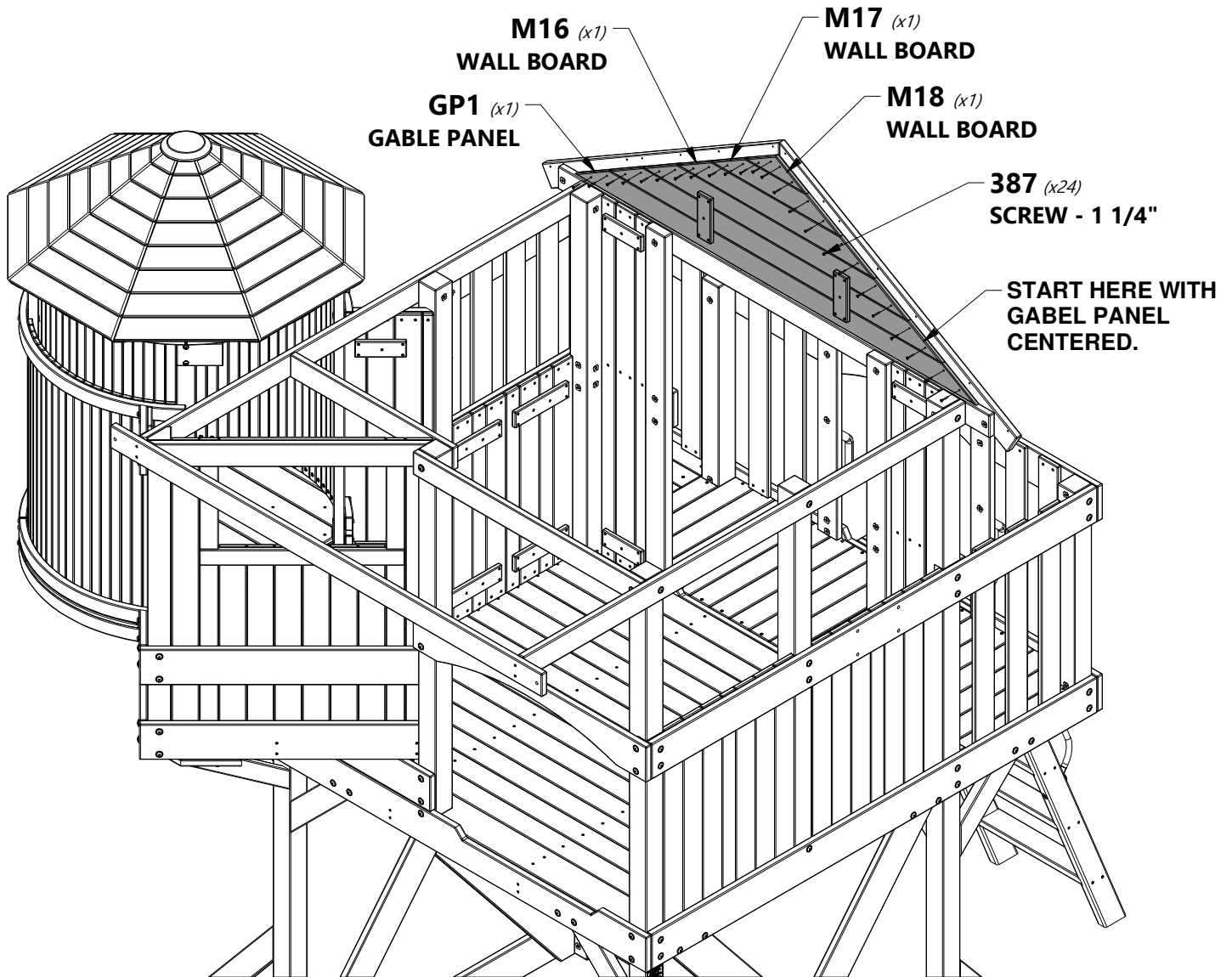

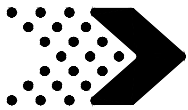

Phase 6

STEP 3

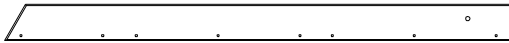

H15 | RAFTER - W4L08526
(x2) | 1"x3 3/8"x47 5/8" (24x86x1209)



H100378 | BOLT WH BLK
(x2) | 5/16x1 3/4



H100379 | T-NUT BLK
(x2) | 5/16



H100198 | WASHER LOCK EXT BLK
(x2) | 8x19



TIP:
WE RECOMMEND INSTALLING T-NUTS INTO
BOARDS BEFORE ASSEMBLY.

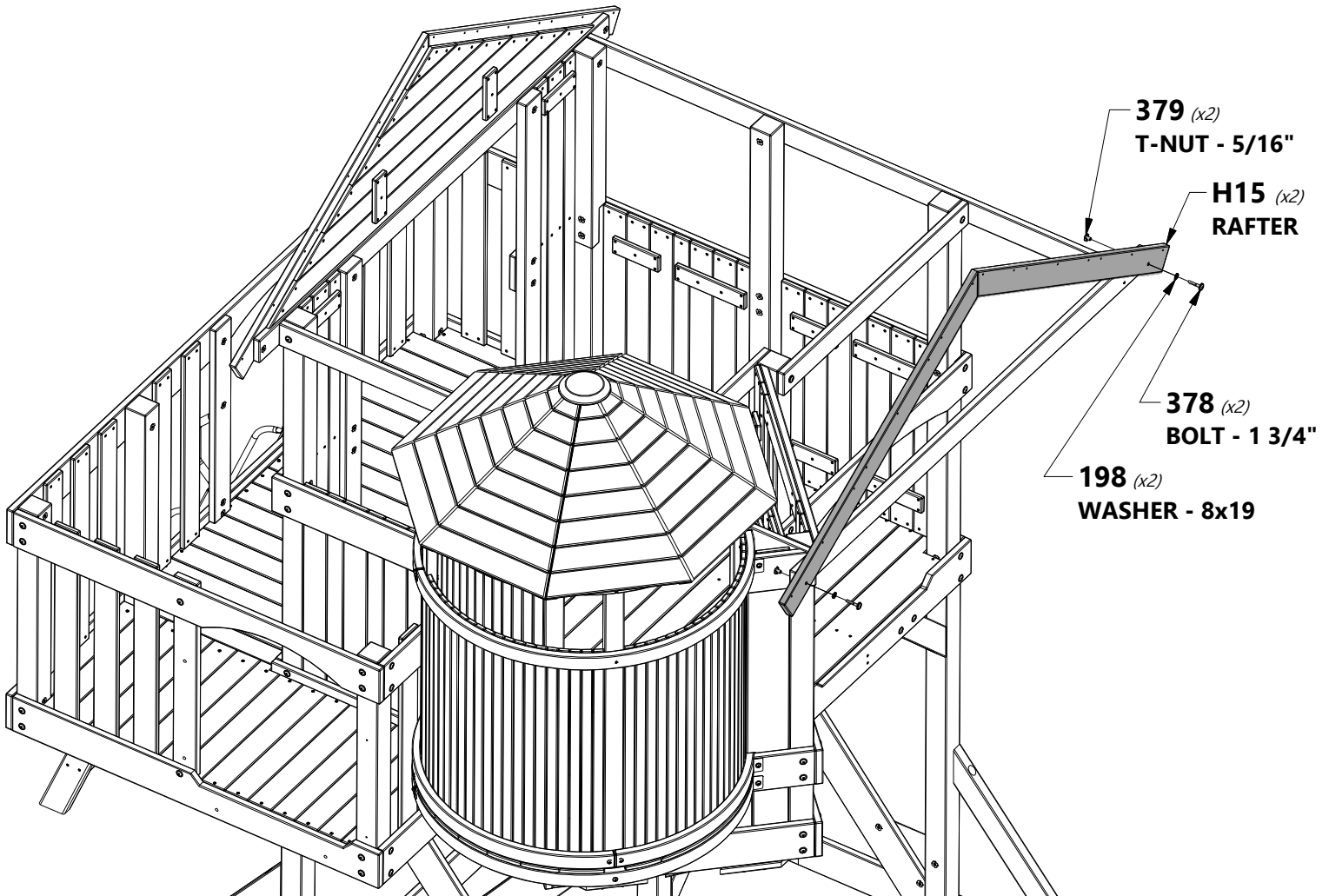

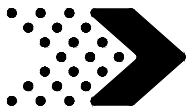

Phase 6

STEP 4

M16 | WALL BOARD - W4L08530
 (x1) | 5/8"x3 3/8"x34 1/8" (16x86x867)

M17 | WALL BOARD - W4L08531
 (x1) | 5/8"x3 3/8"x22 3/8" (16x86x567)

M18 | WALL BOARD - W4L08532
 (x1) | 5/8"x3"x10 1/2" (16x77x268)

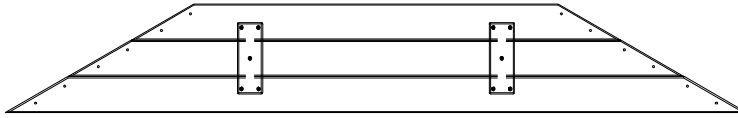

GP1 | GABLE PANEL - W2A02914
 (x1) | 1 1/4"x69 1/2"x10 3/16" (32x1766x259)



H100387 | SCREW PFH BLK
 (x24) | 8x1-1/4

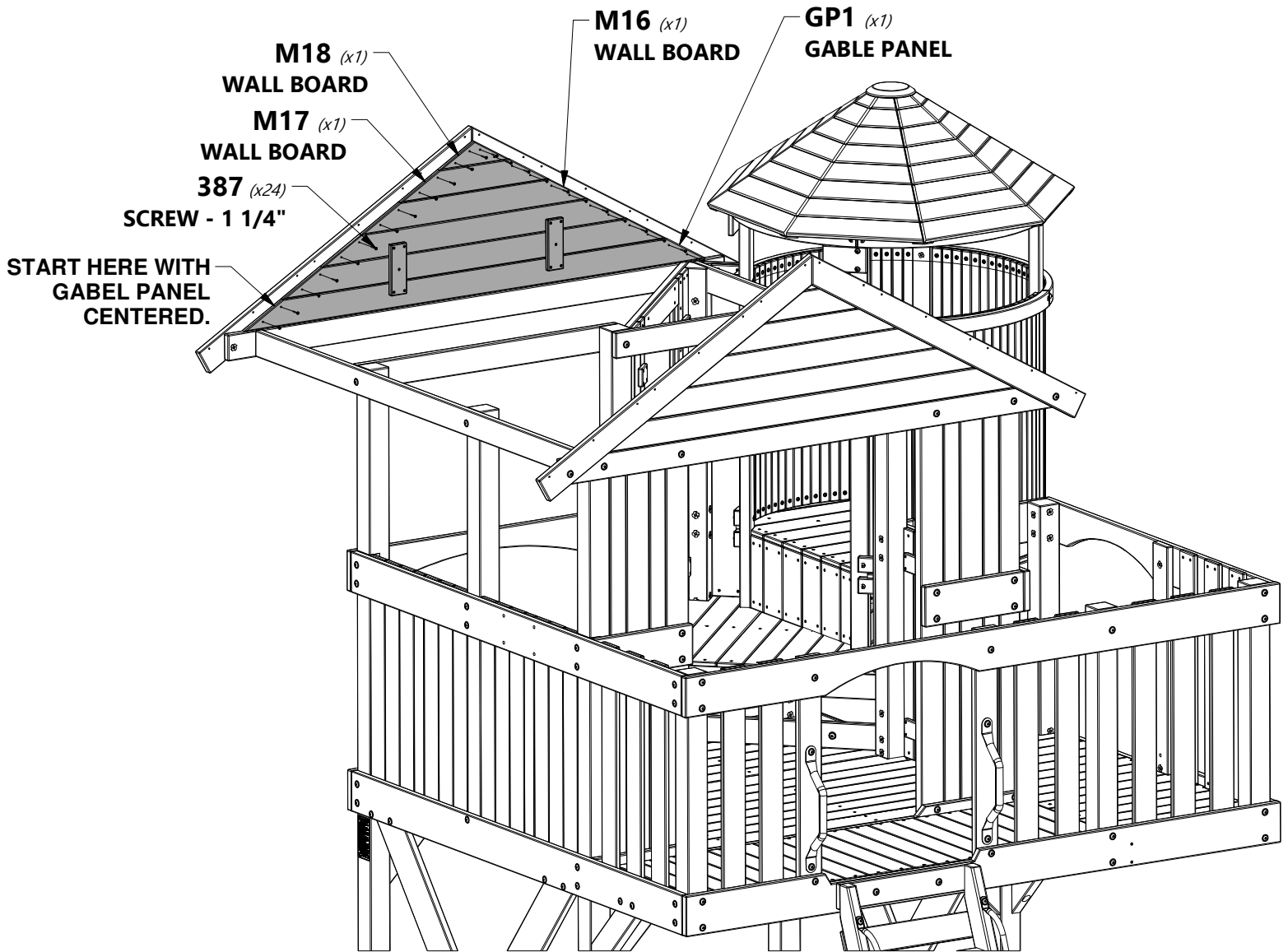

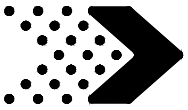

Phase 6

STEP 5

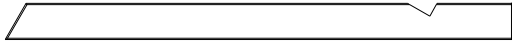

H16 | RAFTER - W4L08527
(x2) | 1"x3 3/8"x47 5/8" (24x86x1209)



N6 | RAFTER CLEAT - W4L11446
(x1) | 5/8"x2 3/8"x3 1/8" (16x60x80)

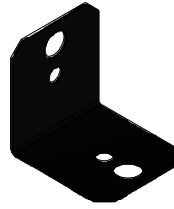

A4M00555 | 90° L-BRACKET - BLK
(x2)



H100392 | SCREW PWH BLK
(x4) | 8x3/4



H100387 | SCREW PFH BLK
(x4) | 8x1-1/4

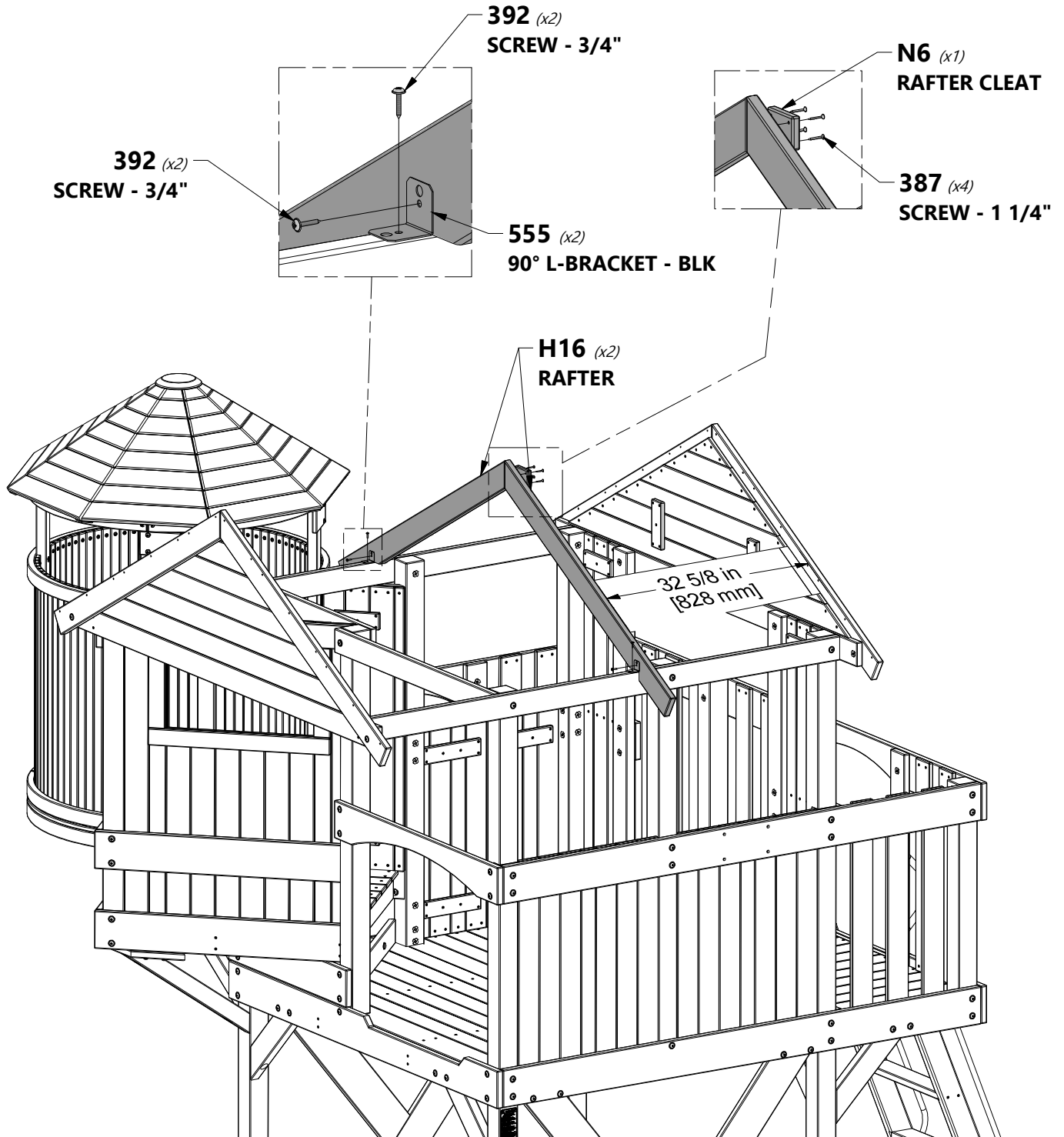

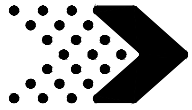

Phase 6

STEP 6

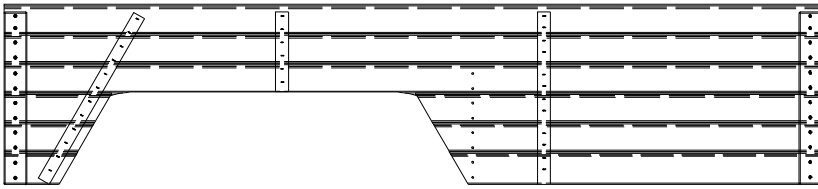

RP03 | ROOF PANEL - W2A02185
(x1) 1 9/16"x18 3/4"x85 3/16" (40x476x2165)



H100200 | SCREW PFH BLK
(x8) 8x1-1/2



H100391 | SCREW PFH BLK
(x6) 8x2

391 (x6)
SCREW - 2"
BOTH ENDS



TIP:
WE RECOMMEND INSTALLING THE ROOF FASTENERS ON THE RIGHT SIDE USING A SMALL HAND OPERATED PHILLIPS SCREW DRIVER.

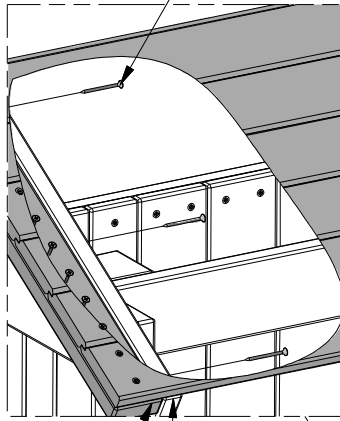

FLUSH

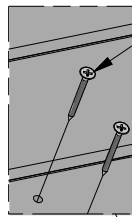

200 (x8)
SCREW - 1 1/2"

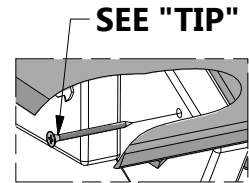

SEE "TIP" ABOVE.

RP03 (x1)
ROOF PANEL

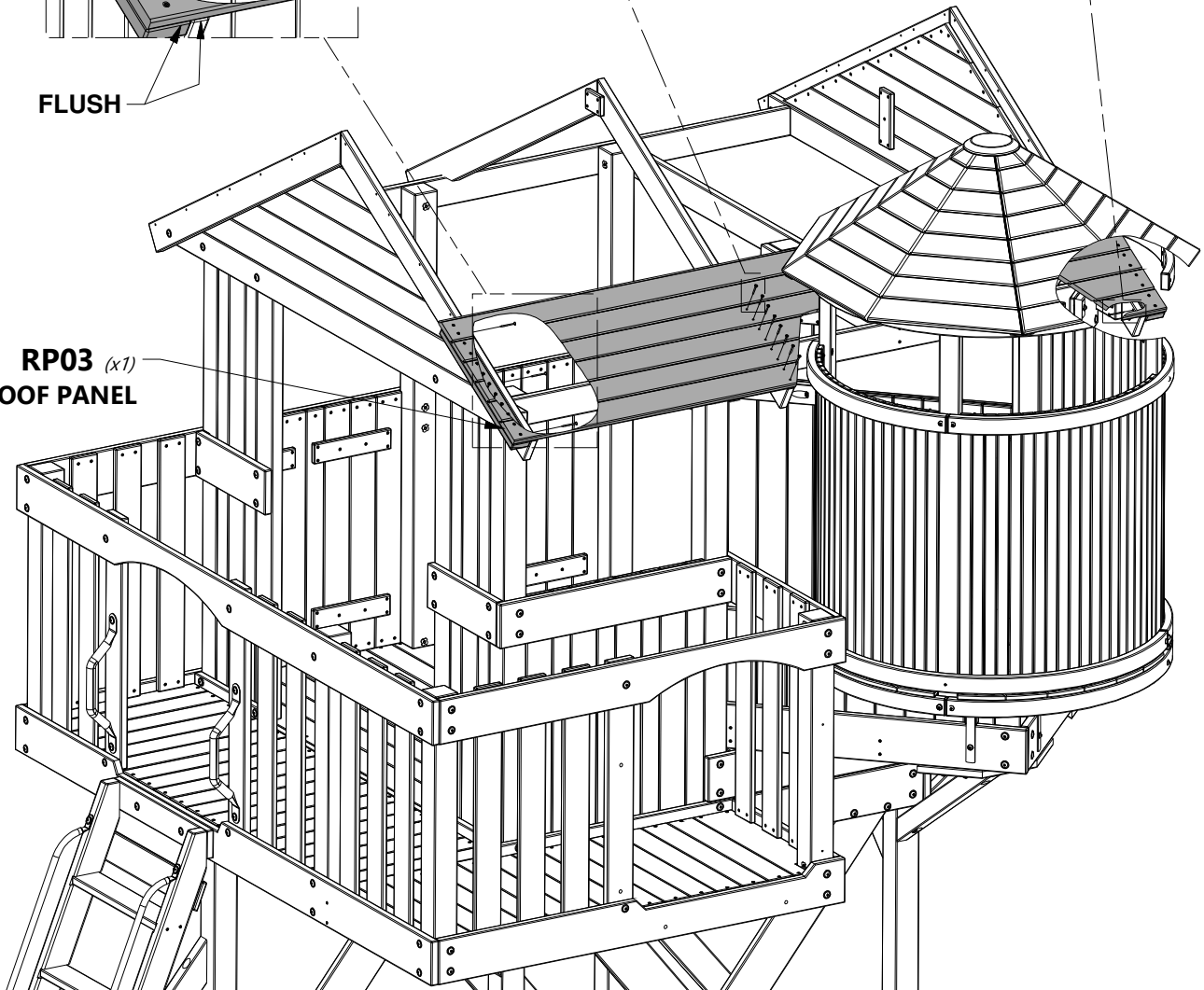

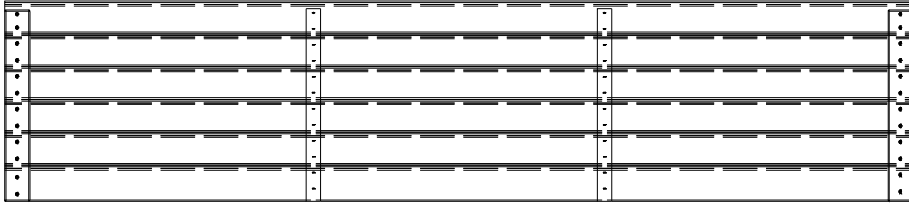
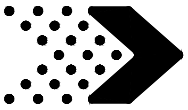

RP04 | ROOF PANEL - W2A02186
(x1) 1 9/16"x18 3/4"x85 1/4" (40x476x2165)



H100391 | SCREW PFH BLK
(x6) 8x2

391 (x6)
SCREW - 2"
BOTH ENDS

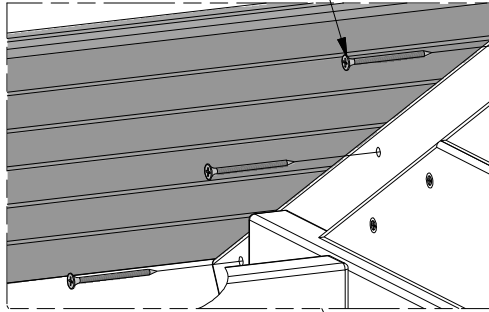

RP04 (x1)
ROOF PANEL

FLUSH

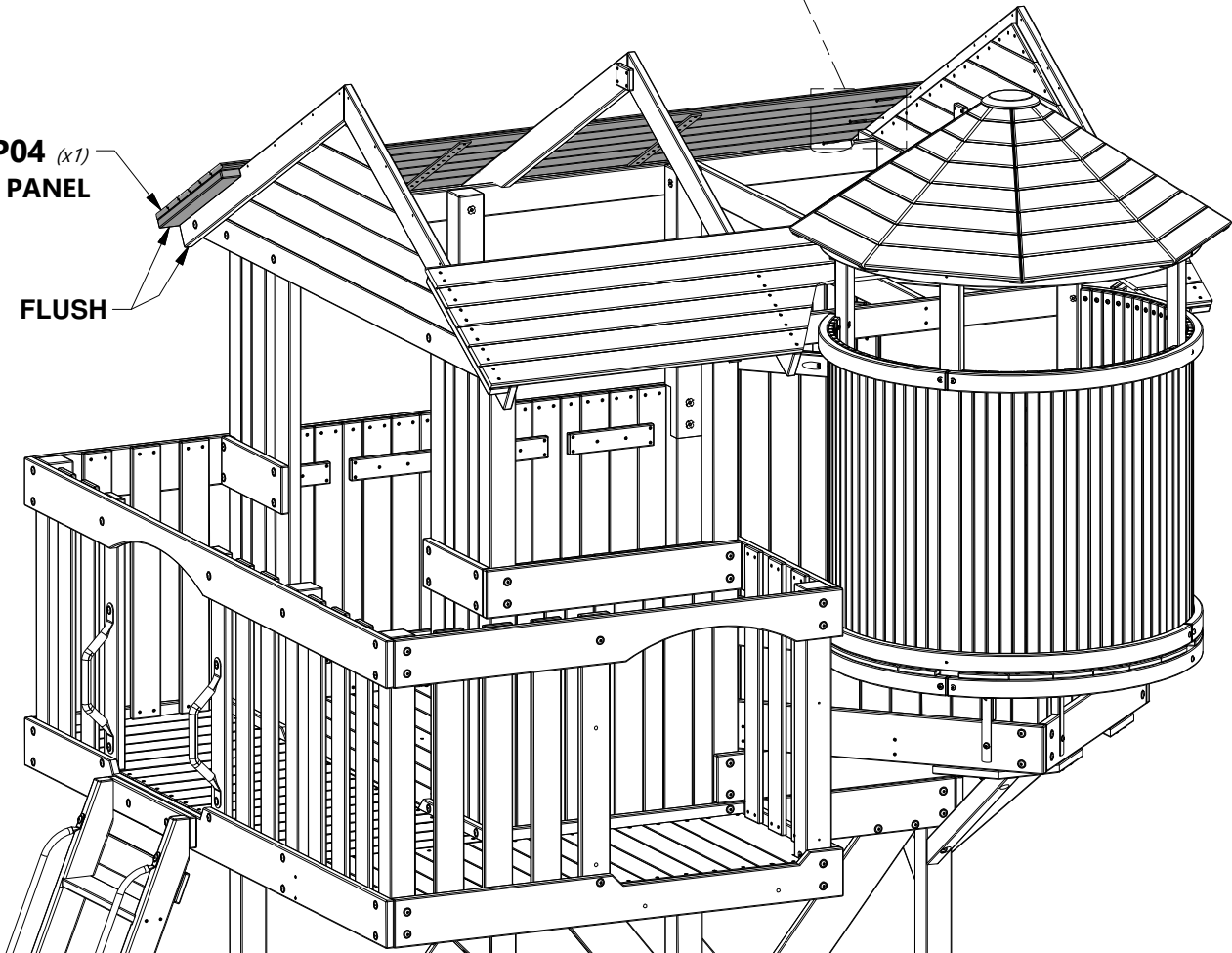

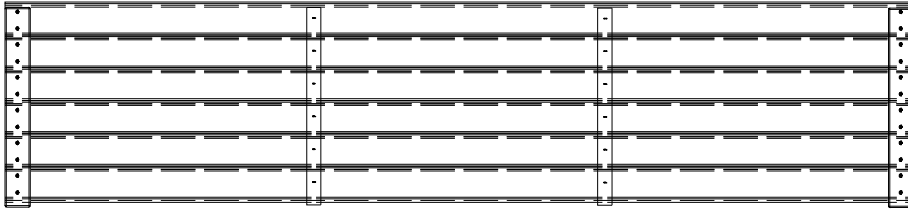
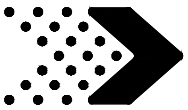

RP02 | ROOF PANEL - W2A020184
(x1) | 1 9/16"x19 1/4"x85 3/16" (40x488x2165)



H100391 | SCREW PFH BLK
(x6) | 8x2

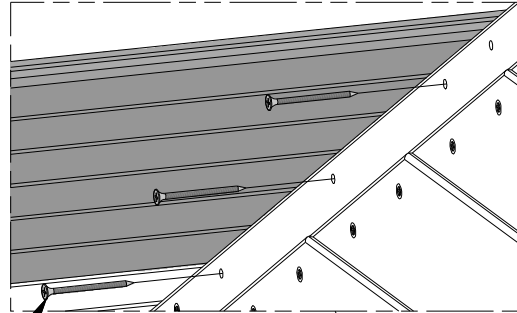

391 (x6)
SCREW - 2"
BOTH ENDS

RP02 (x1)
ROOF PANEL

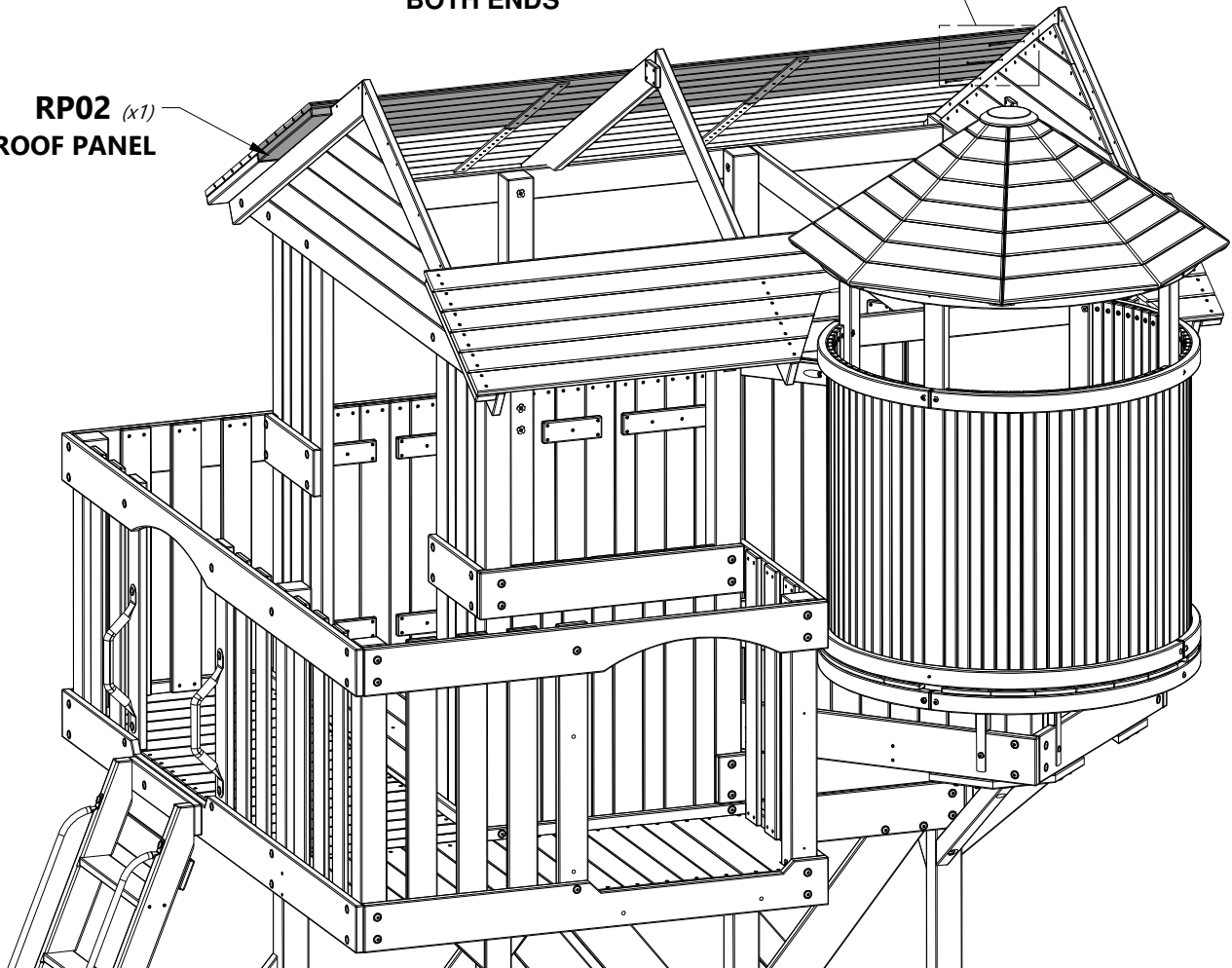

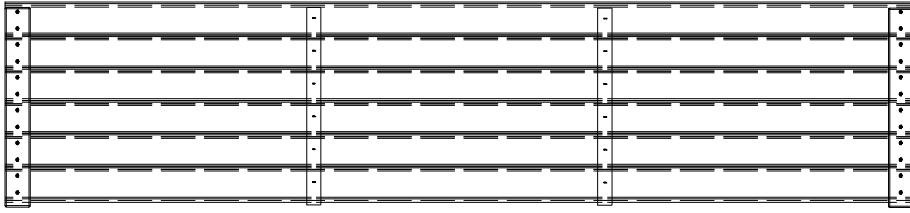
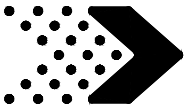

RP02 | ROOF PANEL - W2A020184
(x1) | 1 9/16"x19 1/4"x85 3/16" (40x488x2165)



H100391 | SCREW PFH BLK
(x6) | 8x2

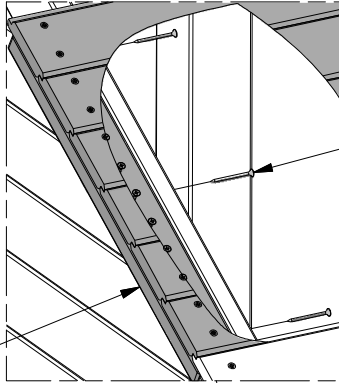

391 (x6)
SCREW - 2"
BOTH ENDS

RP02 (x1)
ROOF PANEL

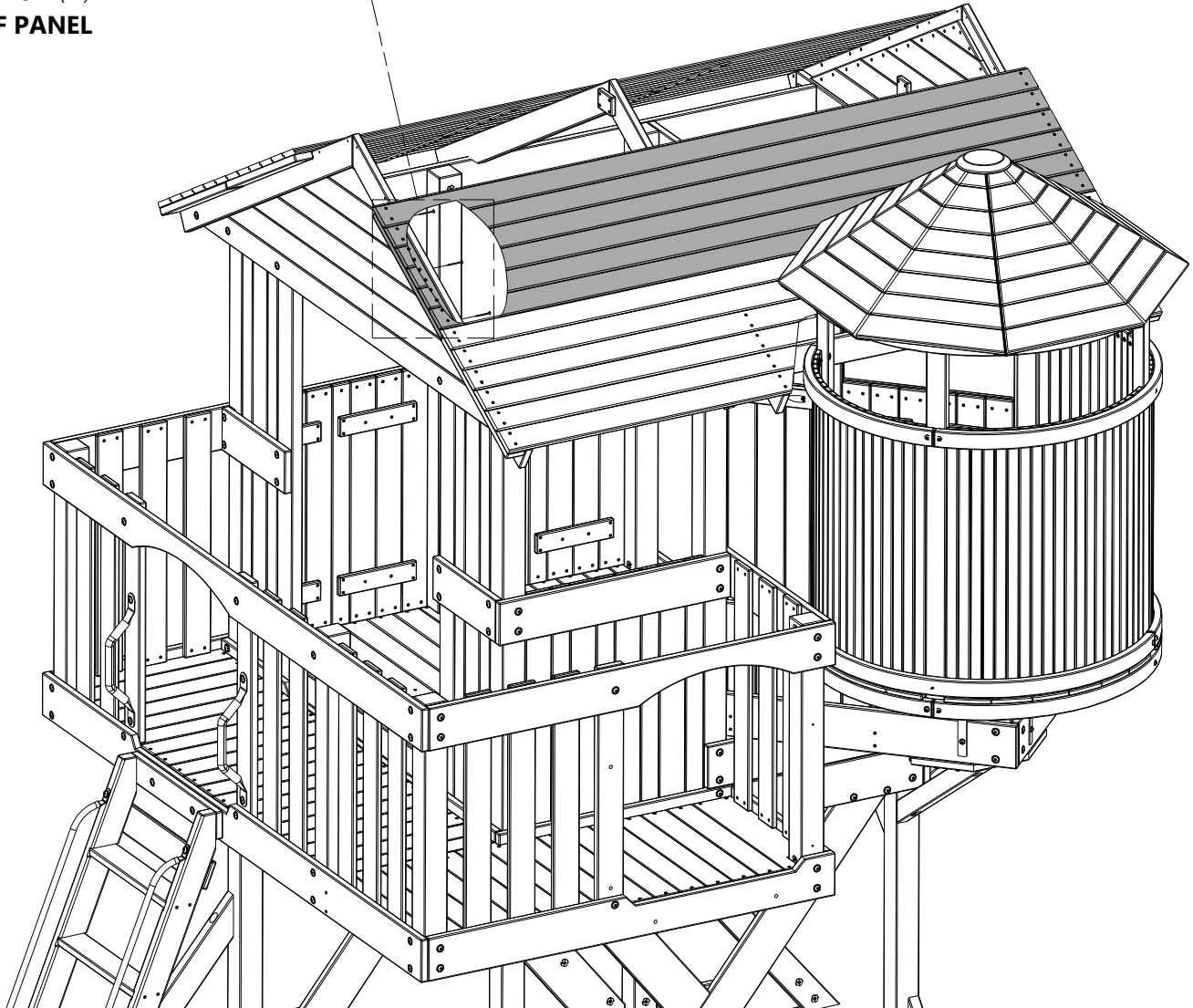

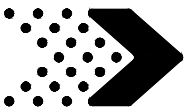

RP01 | ROOF PANEL - W2A02182
(x1) | 1/16"x1/16"x1/16" (40x287x2165)



H100391 | SCREW PFH BLK
(x4) | 8x2

RP01 (x1)
ROOF PANEL

391 (x4)
SCREW - 2"

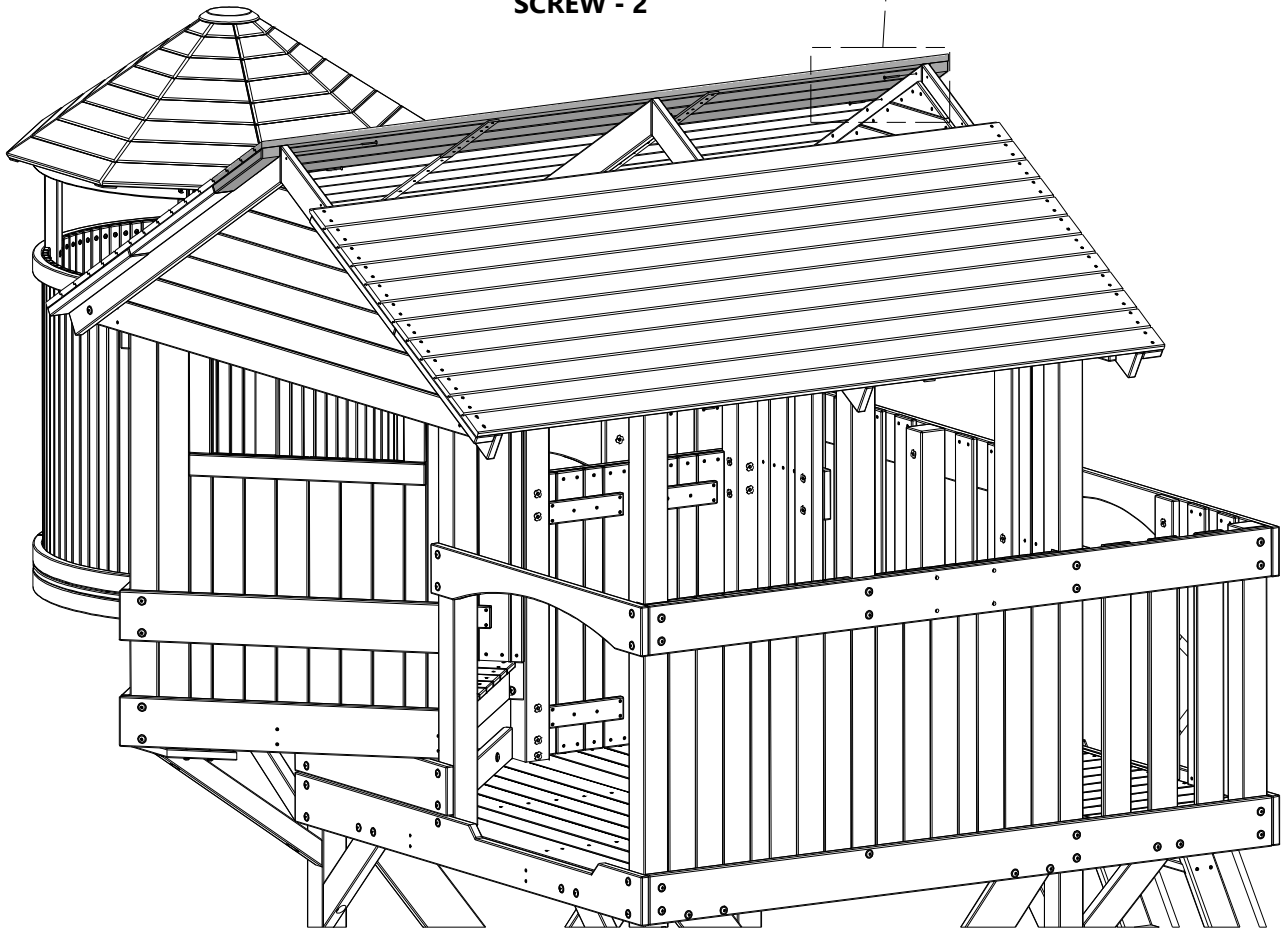
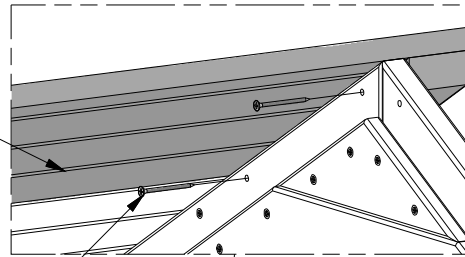

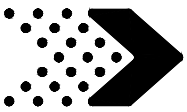

RP01 | ROOF PANEL - W2A02182
(x1) | 1/16"x1/16"x1/16" (40x287x2165)



H100391 | SCREW PFH BLK
(x4) | 8x2

ROOF EDGES SHOULD MEET WITH NO GAP SHOWING.

391 (x4)
SCREW - 2"

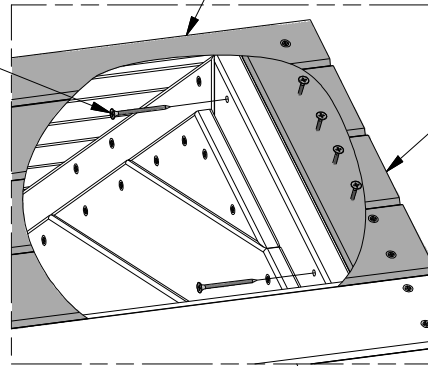

RP01 (x1)
ROOF PANEL

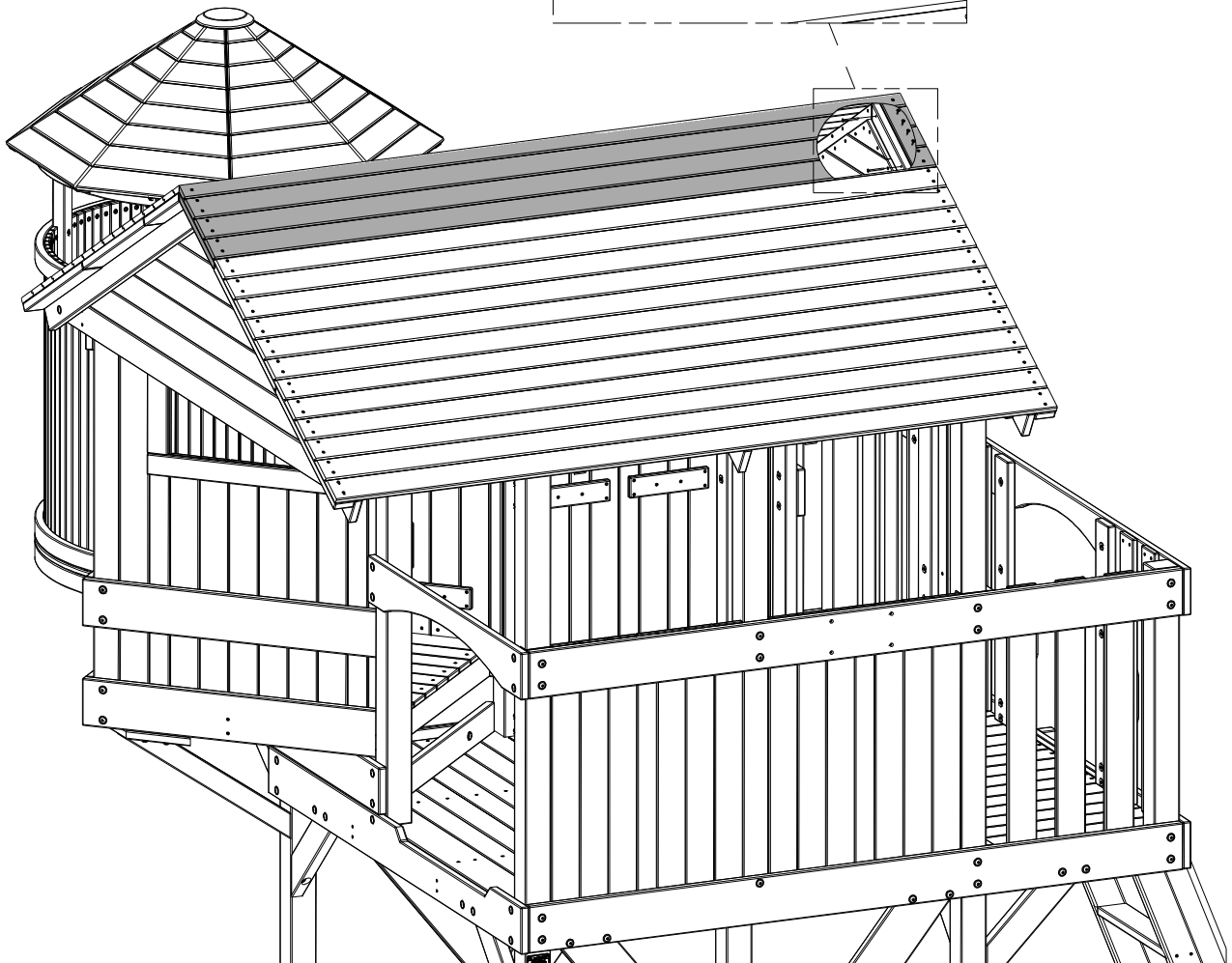



Phase 7

STEP 1

M28 | ROCK WALL BOARD - W4L12833
(x4) | 5/8"x3 3/8"x23 1/4" (16x86x590)

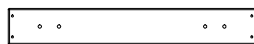

M29 | ROCK WALL BOARD - W4L12834
(x5) | 5/8"x3 3/8"x23 1/4" (16x86x590)

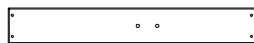

A6P00036 | GREEN HC ROCK #1
(x6)



A6P00037 | GREEN HC ROCK #2
(x7)



H100489 | BOLT PTH BLK
(x26) | 1/4x3/4



H100473 | WASHER LOCK INT BLK
(x26) | 8x15



H100398 | T-NUT 1/4 BLK
(x26) | 1/4



TIP:

WE RECOMMEND INSTALLING T-NUTS INTO BOARDS BEFORE ASSEMBLY.



NOTE:

ASSEMBLE THE ROCK WALL BOARD SUB ASSEMBLIES AS FOLLOWS:

1. LEFT ROCK - SUB ASSEMBLY - x3
2. DOUBLE ROCK - SUB ASSEMBLY - x4
3. RIGHT ROCK - SUB ASSEMBLY - x2

****PLACE ROCKS AS DESIRED!**

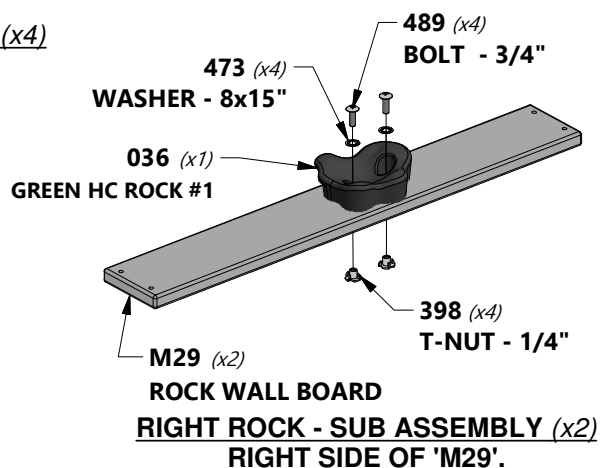
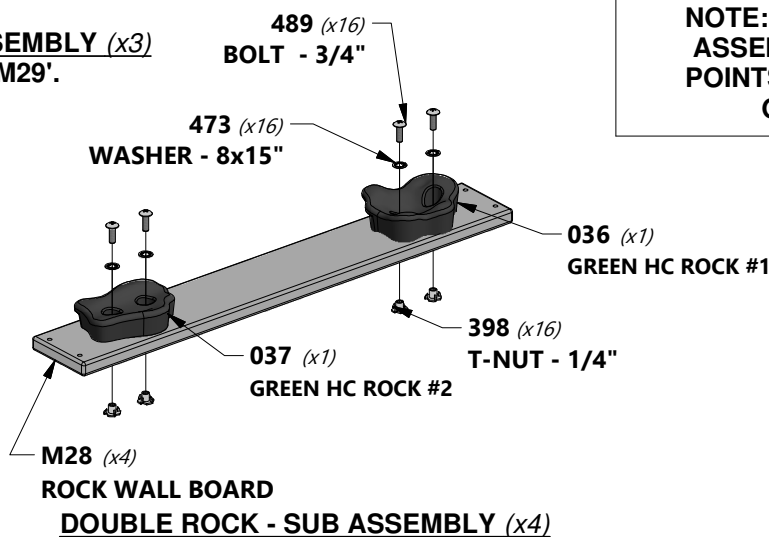
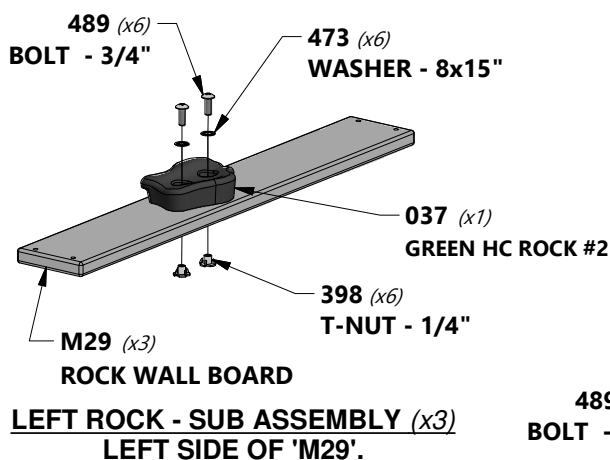

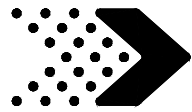

Phase 7

STEP 2

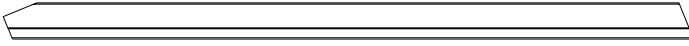

E3 | LEFT RAIL - W4L12830
(x1) | 1 3/8"x3 3/8"x64 3/4" (36x86x1645)



E4 | RIGHT RAIL - W4L12831
(x1) | 1 3/8"x3 3/8"x64 3/4" (36x86x1645)



M26 | ROCK WALL BOARD - W4L12832
(x9) | 5/8"x3 3/8"x23 1/4" (16x86x590)



M31 | ROCK WALL BOARD - W4L12837
(x1) | 5/8"x2 3/4"x23 1/4" (16x69x590)

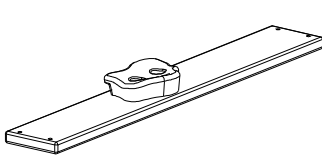

LEFT ROCK - SUB ASSEMBLY (x3)
(FROM PHASE 7 - STEP 1).

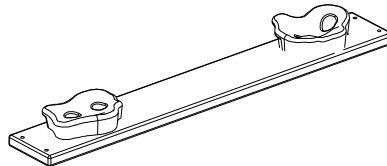

DOUBLE ROCK - SUB ASSEMBLY (x4)
(FROM PHASE 7 - STEP 1).

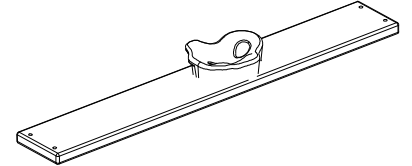

RIGHT ROCK - SUB ASSEMBLY (x2)
(FROM PHASE 7 - STEP 1).



H100200 | SCREW PFH BLK
(x76) | 8x1-1/2

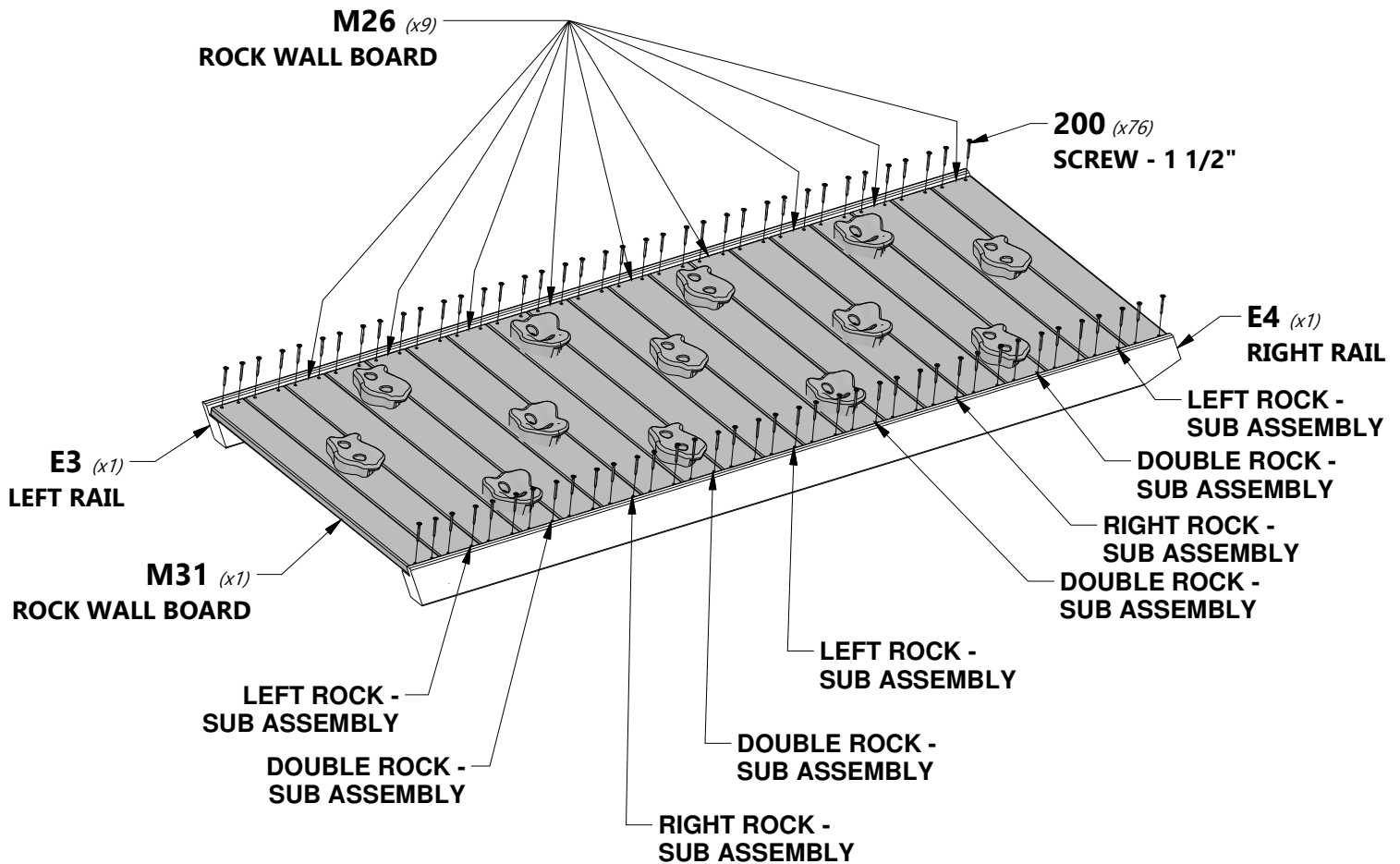

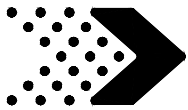

N4 | **ROCK WALL CLEAT - W4L12847**
(x1) | 5/8"x2 3/8"x61 3/4" (16x60x1568)



H100380 | **SCREW PFH BLK**
(x12) | 8x1 1/8"

9 1/2 in
[241 mm]

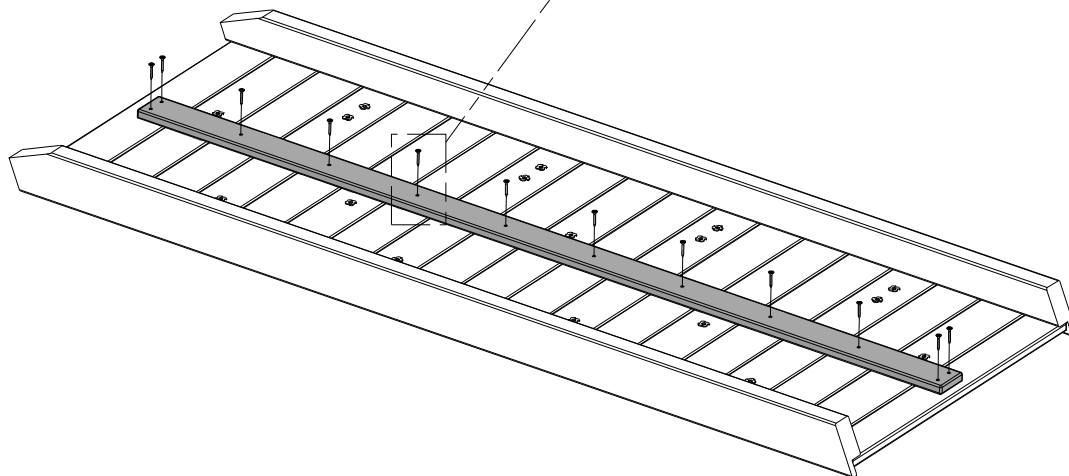
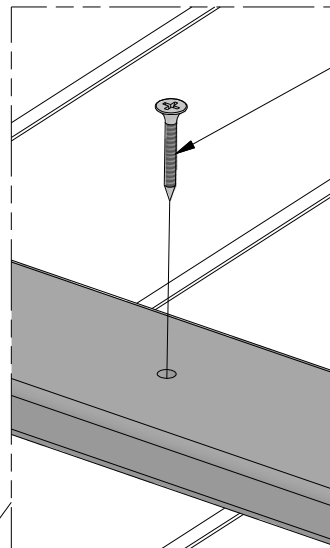
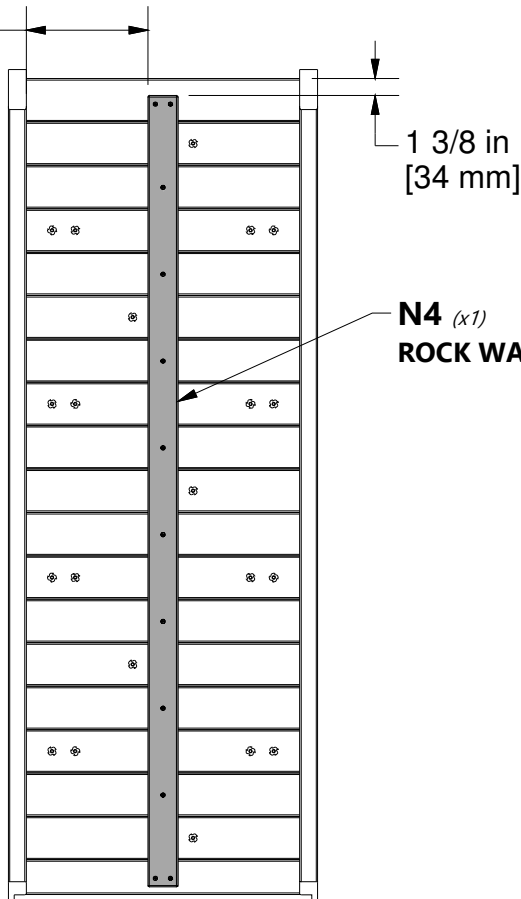

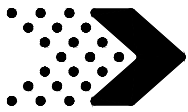

Phase 7

STEP 4

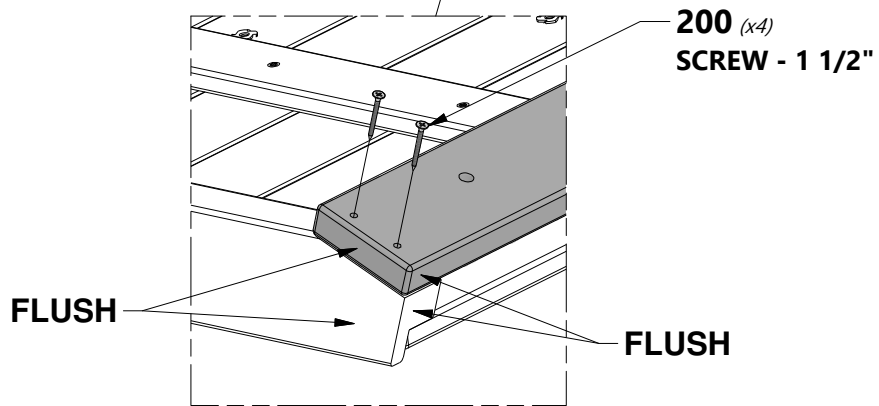
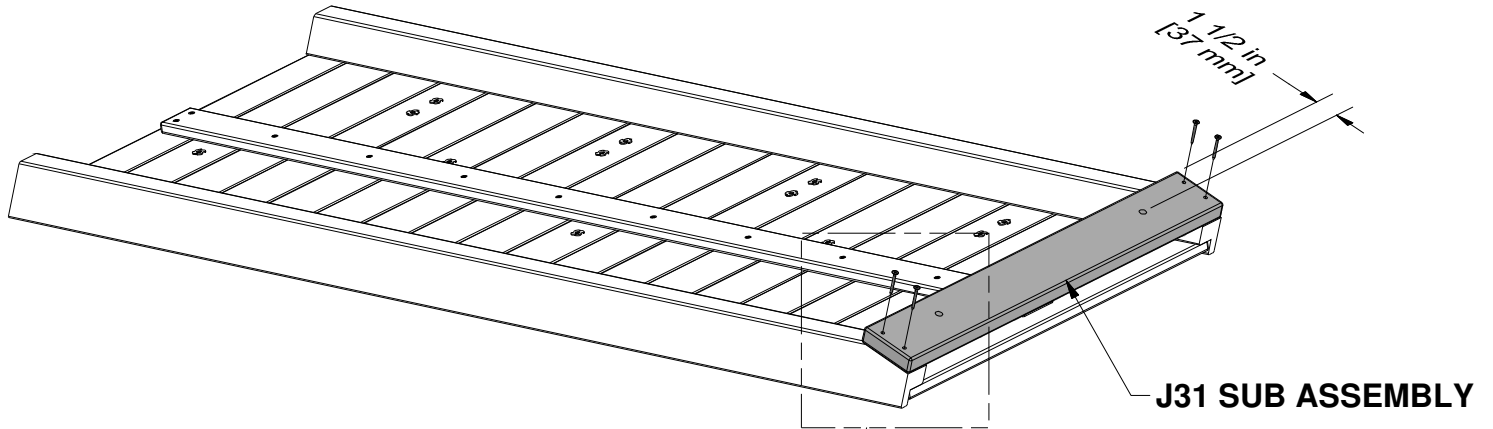
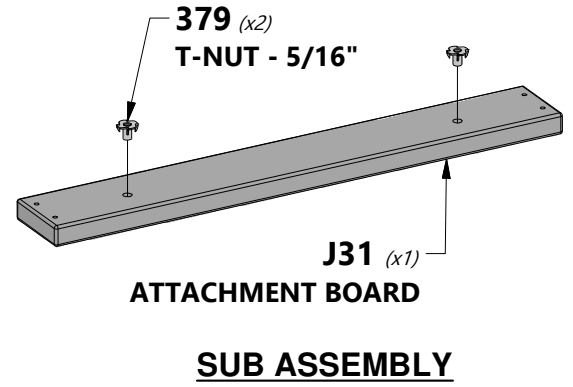
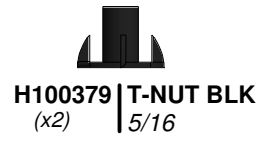
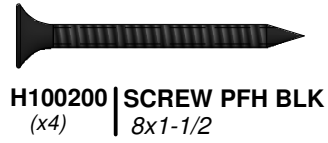
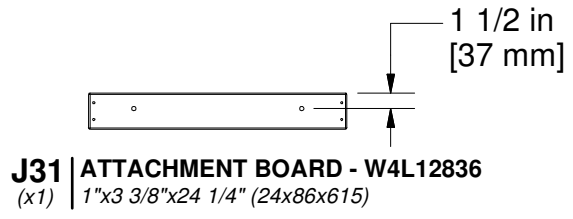

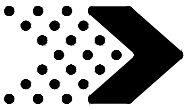

Phase 7

STEP 5

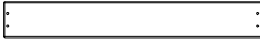

M30 | **ROCK WALL END BOARD - W4L12835**
(x1) | 5/8"x3 3/8"x24 1/4" (16x86x615)



H100200 | **SCREW PFH BLK**
(x4) | 8x1-1/2

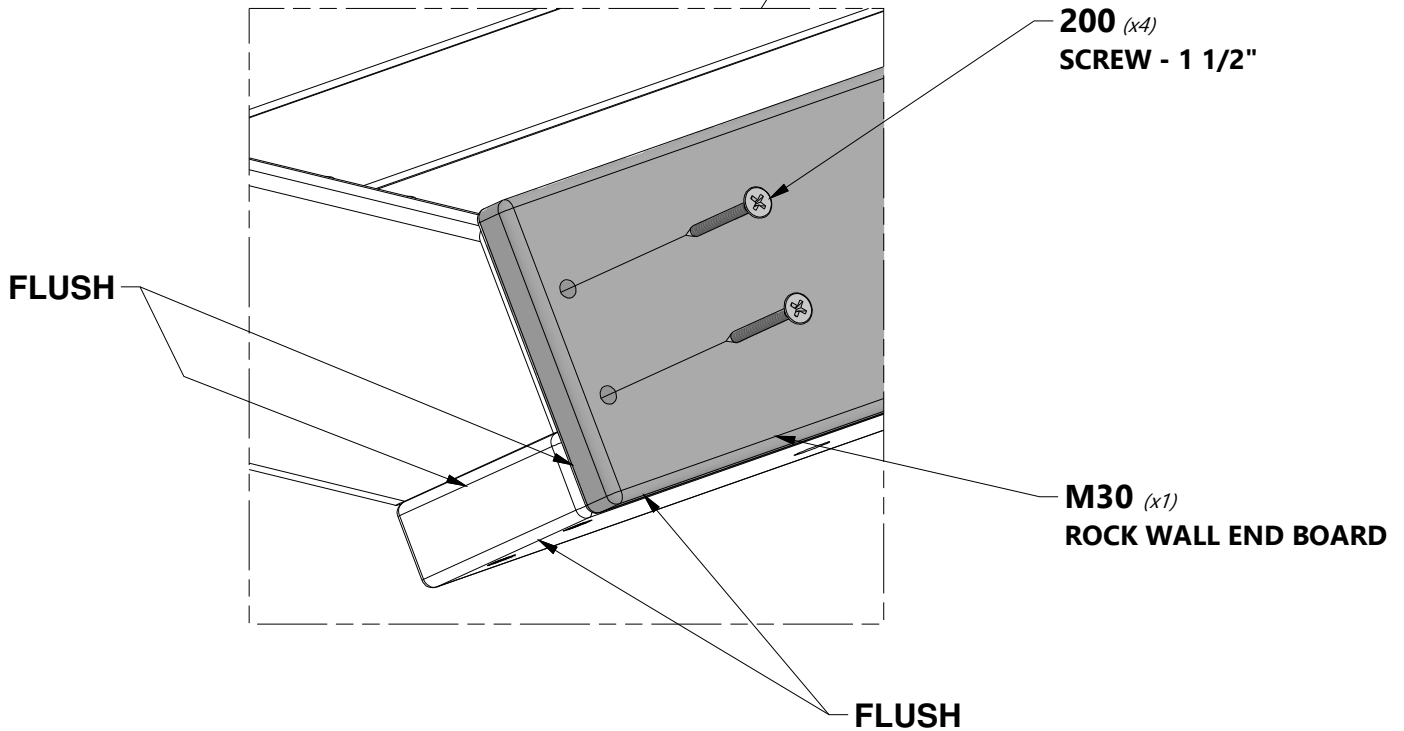
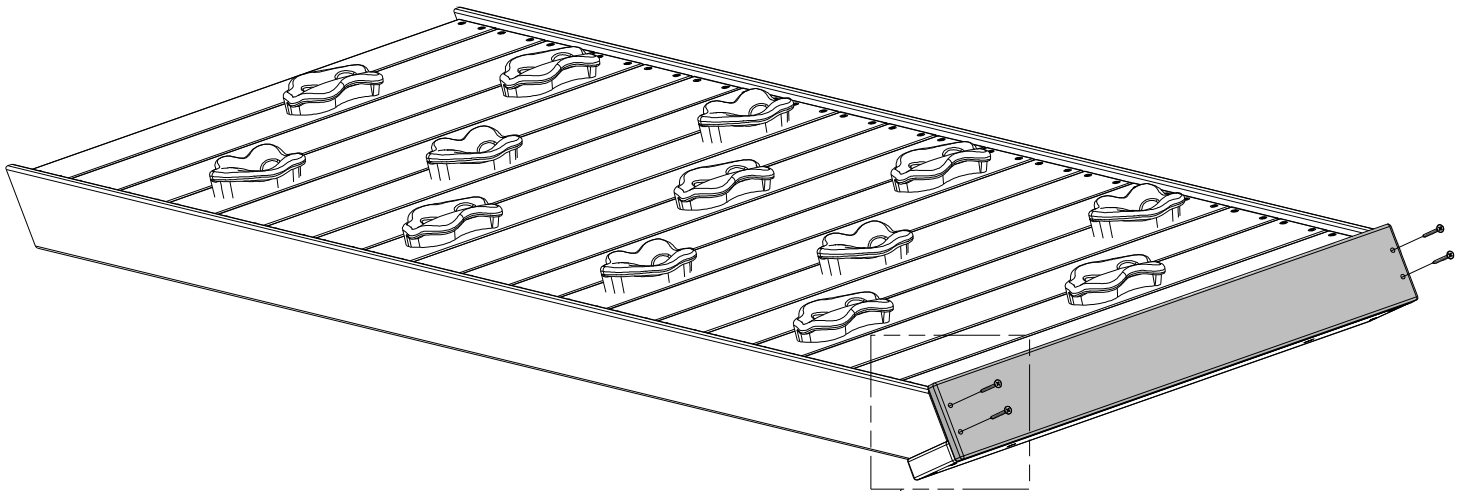

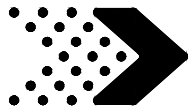

Phase 7

STEP 6

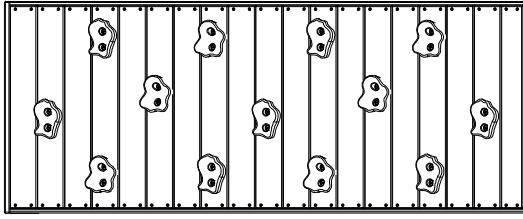

(1) **ROCK WALL ASSEMBLY**
(FROM PREVIOUS STEP).



H100195 | BOLT WH BLK
(x2) | 5/16x2-3/4



H100198 | WASHER LOCK EXT BLK
(x2) | 8x19

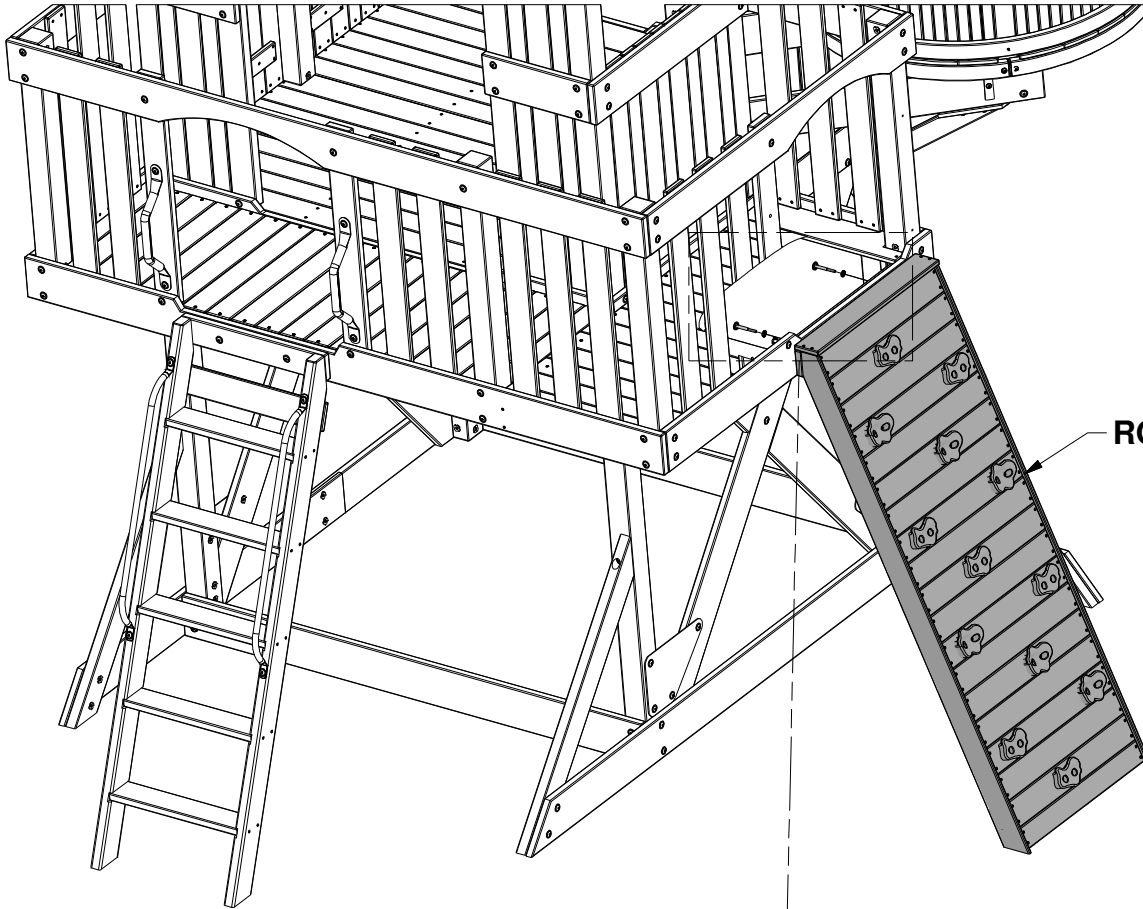

ROCK WALL ASSEMBLY

195 (x2)
BOLT - 2-3/4

198 (x2)
WASHER - 8x19

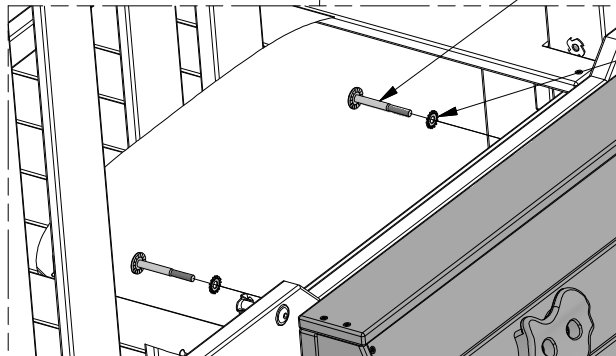

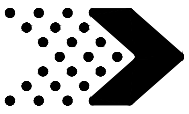

Phase 7

STEP 7



A100118 (x2) | **HAND GRIP METAL GREEN 381 c/c**



H100471 | **LAG SCREW WH BLK**
(x2) | 5/16x1 1/2



H100468 | **BOLT WH BLK**
(x2) | 5/16x1



H100379 | **T-NUT BLK**
(x2) | 5/16



TIP:

WE RECOMMEND INSTALLING T-NUTS INTO BOARDS BEFORE ASSEMBLY.

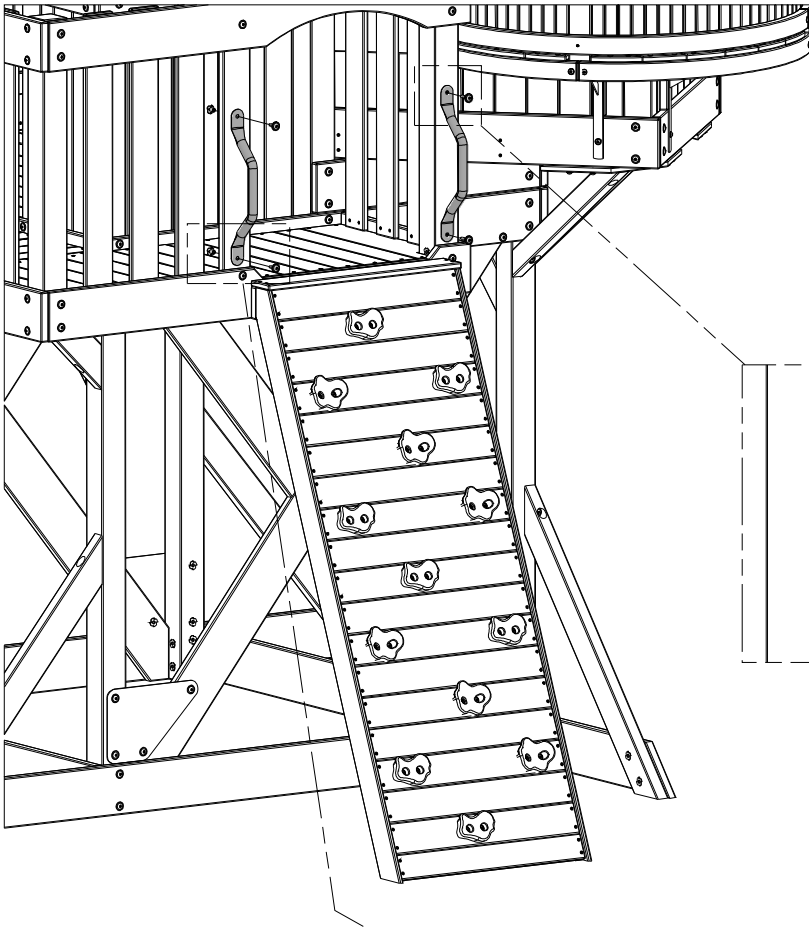

118 (x2)

HAND GRIP METAL GREEN 381 c/c

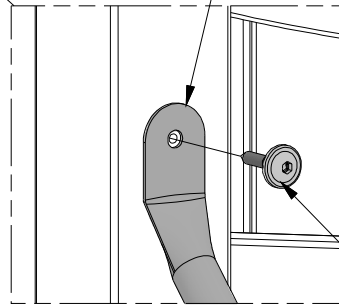

471 (x2)

LAG SCREW - 1 1/2"

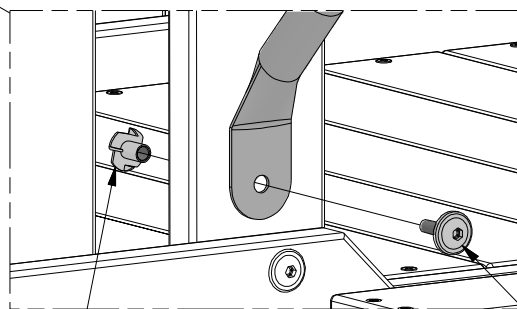

379 (x2)

T-NUT - 5/16"

468 (x2)

BOLT WH - 1"



Phase 8

STEP 1

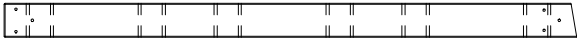

A1 | SWING BEAM - W4L12838
(x1) | 3 3/8"x5 1/4"x89 1/2" (86x134x2274)



A2 | SB 9" BLOCK - W4L08962
(x1) | 3 3/8"x5 1/4"x9" (86x134x228)

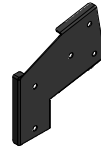

A100326 | SWING BEAM EXTENSION BRACKET-RIGHT
(x1)

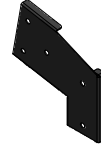

A100325 | SWING BEAM EXTENSION BRACKET-LEFT
(x1)

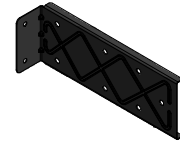

A4M00993 | EXTENDED SWING BEAM BRACKET
(x2)



H100416 | BOLT WH BLK
(x10) | 5/16x3



H100192 | NUT BARREL WH BLK
(x10) | 5/16x7/8

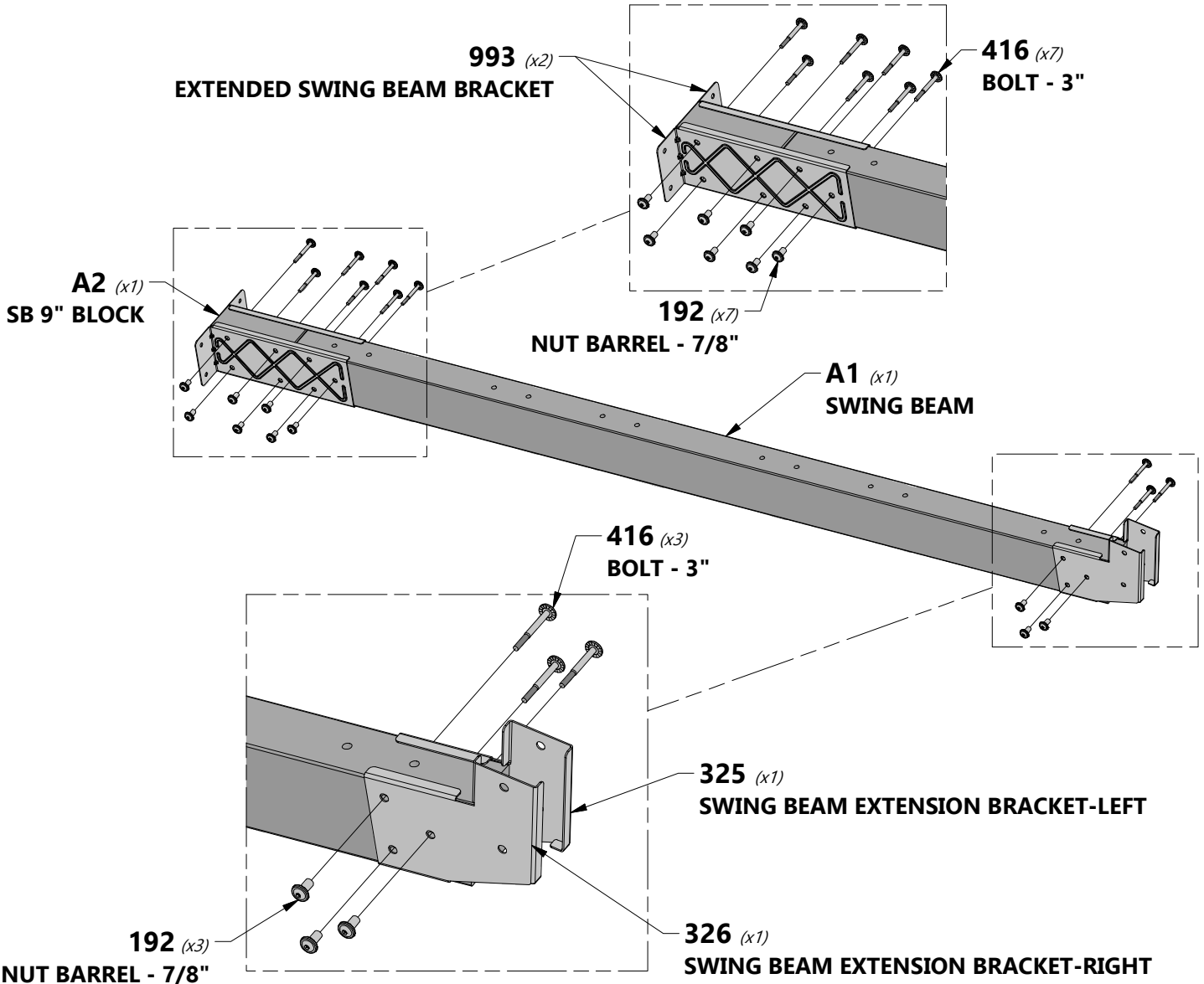

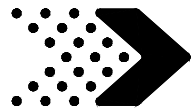

Phase 8

STEP 2



A100164 | BYD ID TAG (LARGE) AGES 3-10
(x1)

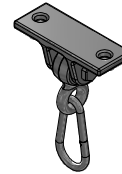

A4M00926 | SINGLE DUCTILE HANGER SD
(x6)



H100665 | BOLT HEX SD
(x12) | 3/8x5 3/4



H100708 | WASHER LOCK INT SD
(x12) | 10x18



H100703 | WASHER FLAT SD
(x12) | 11x25

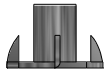

H100700 | T-NUT SD
(x12) | 3/8



H100203 | SCREW PFH BLK
(x4) | 8x1/2



TIP:
WE RECOMMEND INSTALLING T-NUTS INTO
BOARDS BEFORE ASSEMBLY.

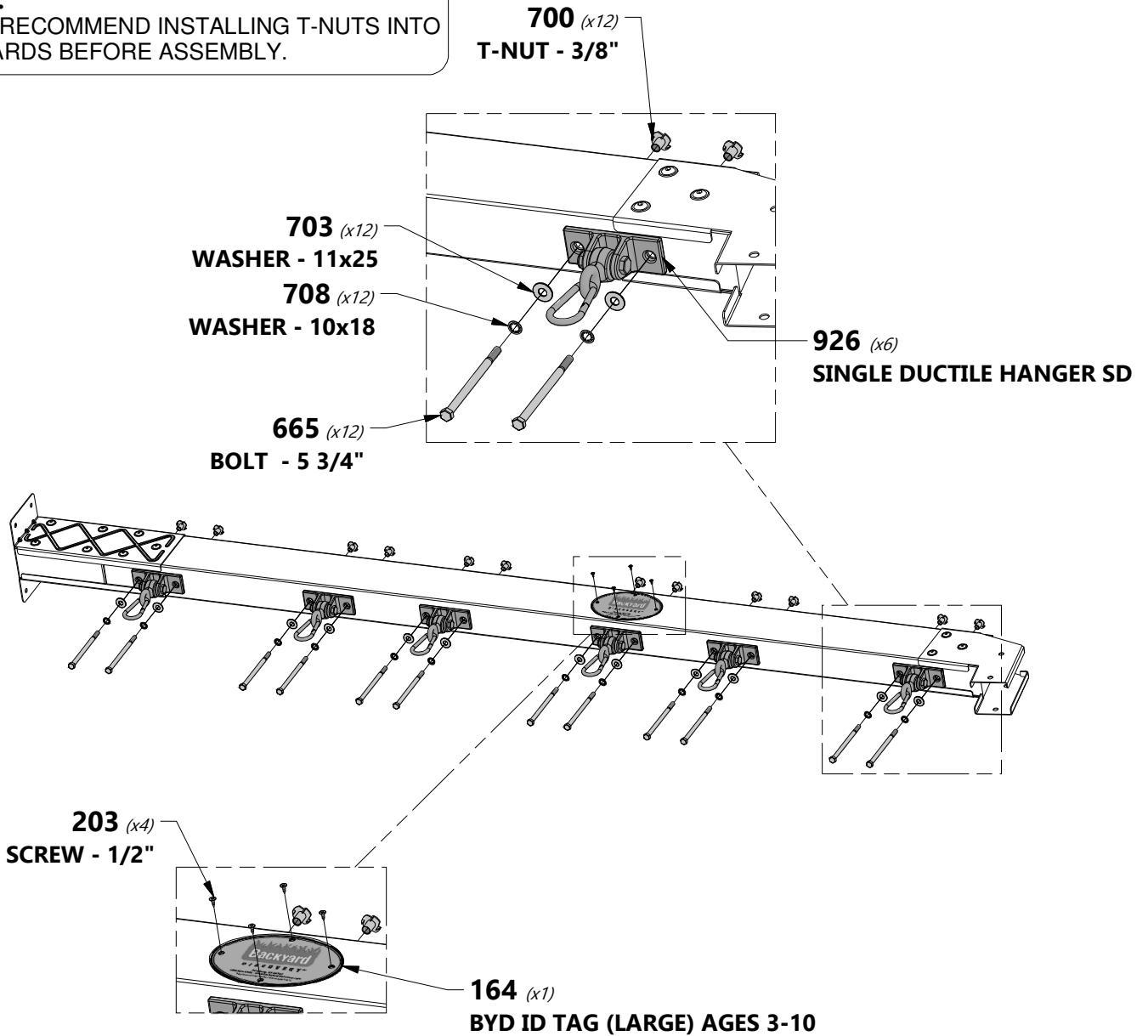

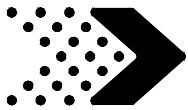

Phase 8

STEP 3

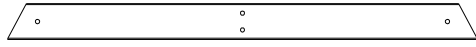

E50 | END SUPPORT - W4L11379
(x1) | 1 3/8"x3 3/8"x44 1/8" (36x86x1120)



E51 | ANGLE BRACE - W4L11378
(x2) | 1 3/8"x3 3/8"x88 3/4" (36x86x2254)

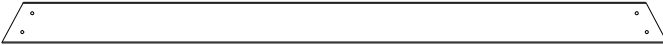

G50 | GROUND BOARD - W4L11380
(x1) | 1"x5 1/4"x86 3/4" (24x134x2202)



SP50 | SWING BEAM SUPPORT - W4L11377
(x1) | 3 3/8"x3 3/8"x49 3/8" (86x86x1254)



H100363 | BOLT WH BLK
(x1) | 5/16X6



H100415 | BOLT WH BLK
(x2) | 5/16x3 3/4



H100205 | BOLT WH BLK
(x2) | 5/16x2-1/4



H100457 | BOLT WH BLK
(x4) | 5/16x2



H100193 | NUT BARREL WH BLK
(x2) | 5/16x1-1/2

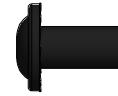

H100192 | NUT BARREL WH BLK
(x7) | 5/16x7/8



H100198 | WASHER LOCK EXT BLK
(x9) | 8x19



H100199 | WASHER LOCK EXT BLK
(x9) | 12x19

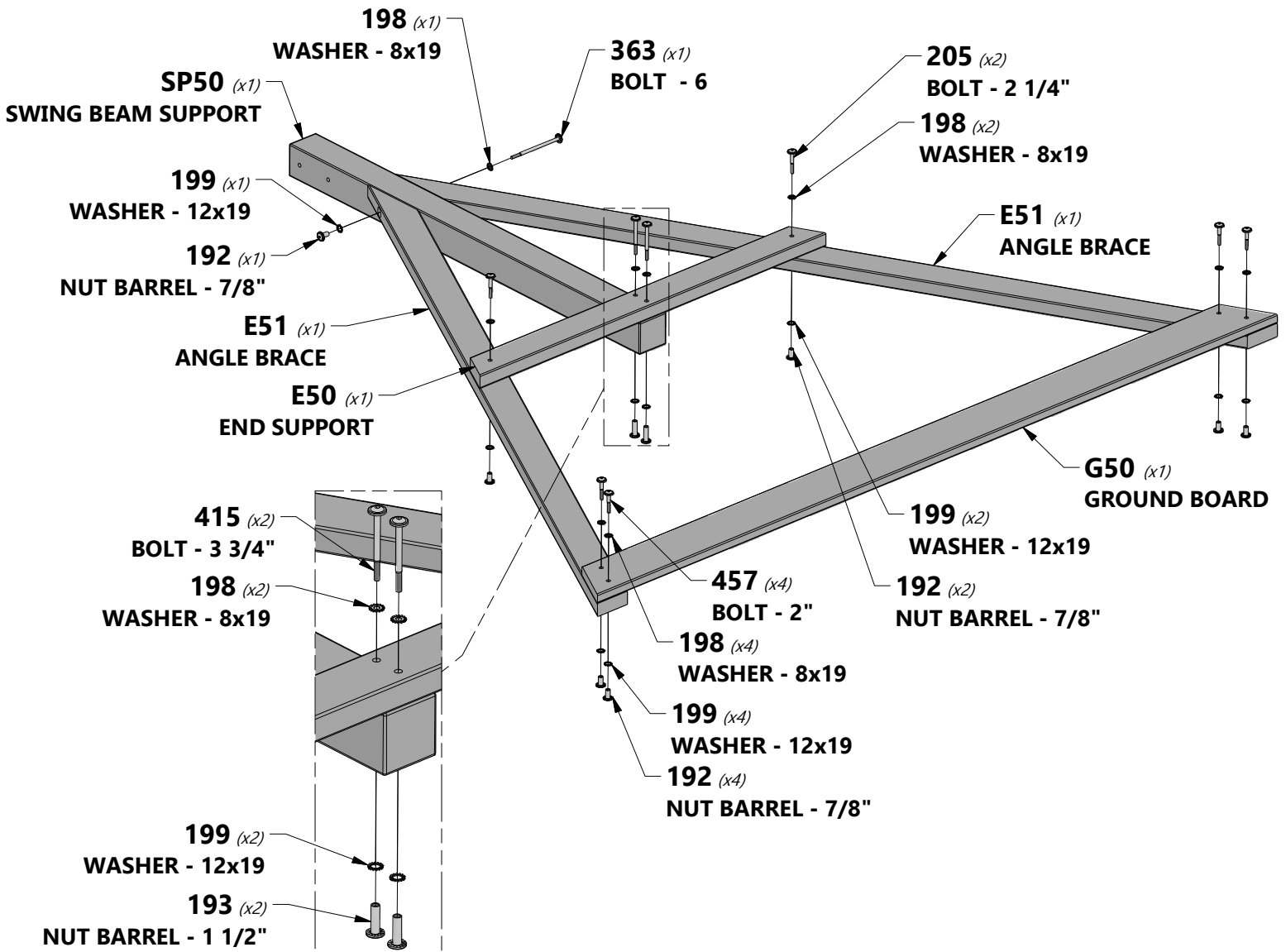

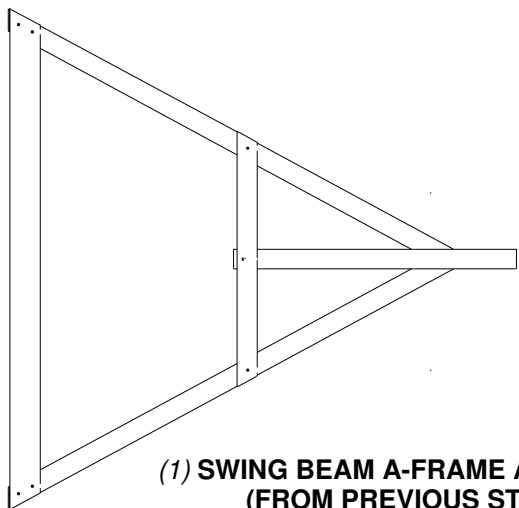

(1) SWING BEAM A-FRAME ASSEMBLY
(FROM PREVIOUS STEP).



H100416 | BOLT WH BLK
(x2) | 5/16x3



H100192 | NUT BARREL WH BLK
(x2) | 5/16x7/8

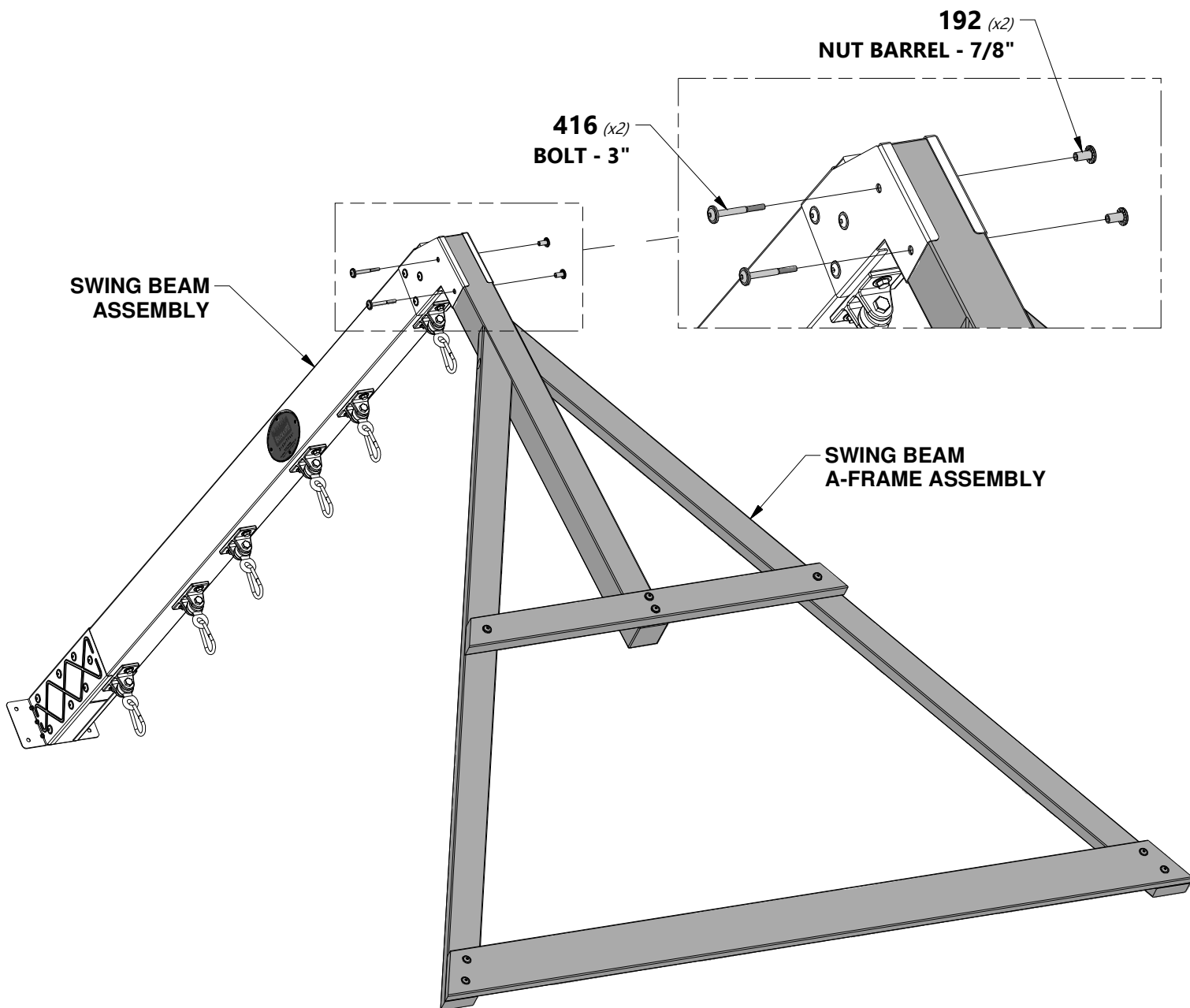

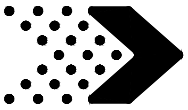

Phase 8

STEP 5

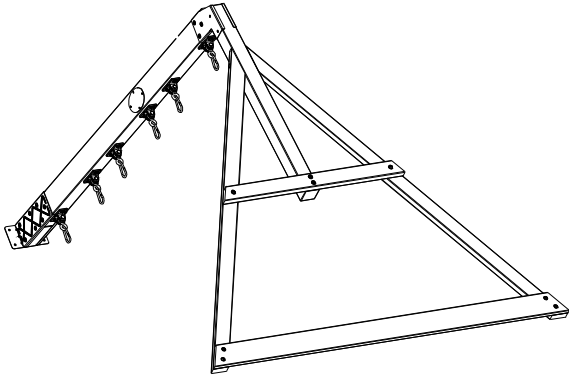

(1) SWING BEAM ASSEMBLY
(FROM PREVIOUS STEP).



H100481 | BOLT HEX BLK
(x4) | 5/16x1 1/4



H100477 | WASHER SPLIT BLK
(x4) | 5/16



H100478 | WASHER FLAT BLK
(x4) | 8x27

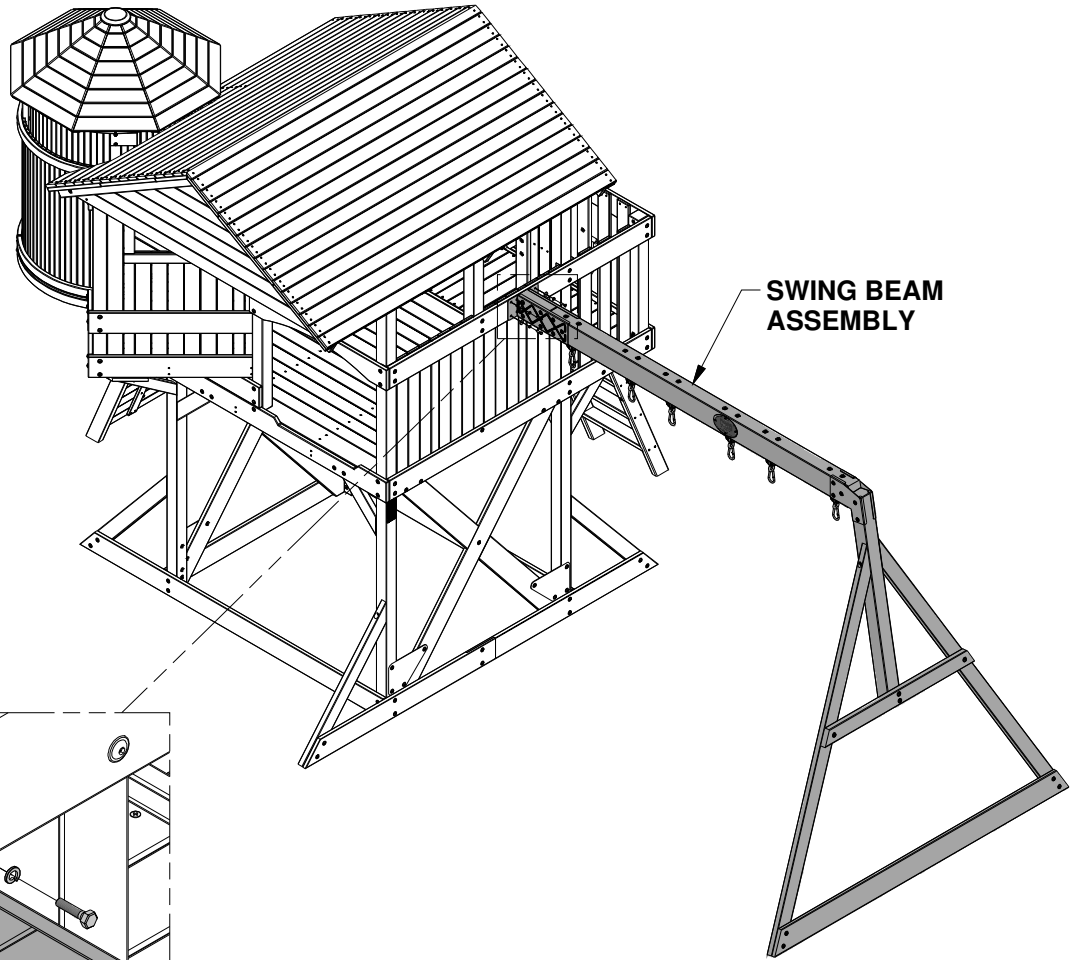

SWING BEAM
ASSEMBLY

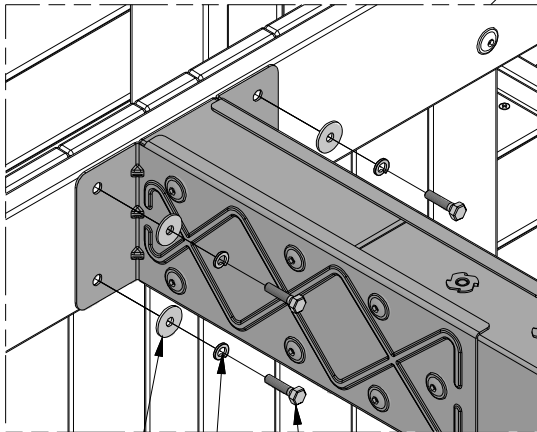

478 (x4)
WASHER - 8x27

481 (x4)
BOLT - 1 1/4"

477 (x4)
WASHER - 5/16

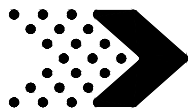

A6P00362 (x2) | 26" HD BELT SWING

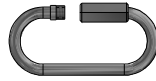

A4M00927 (x4) | QUICK LINK SD

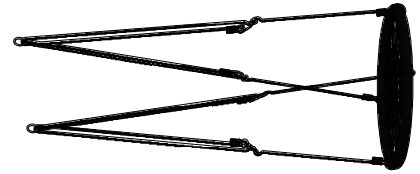

A6P00253 (x1) | 26" WEB SWING SEAT



A4M01005 (x4) | CHAIN GREEN 7mm x 1452mm (57in)



NOTE:
SEE WEB SWING SETUP INSTRUCTIONS, ON THE NEXT PAGE, FOR PROPER INSTALLATION.

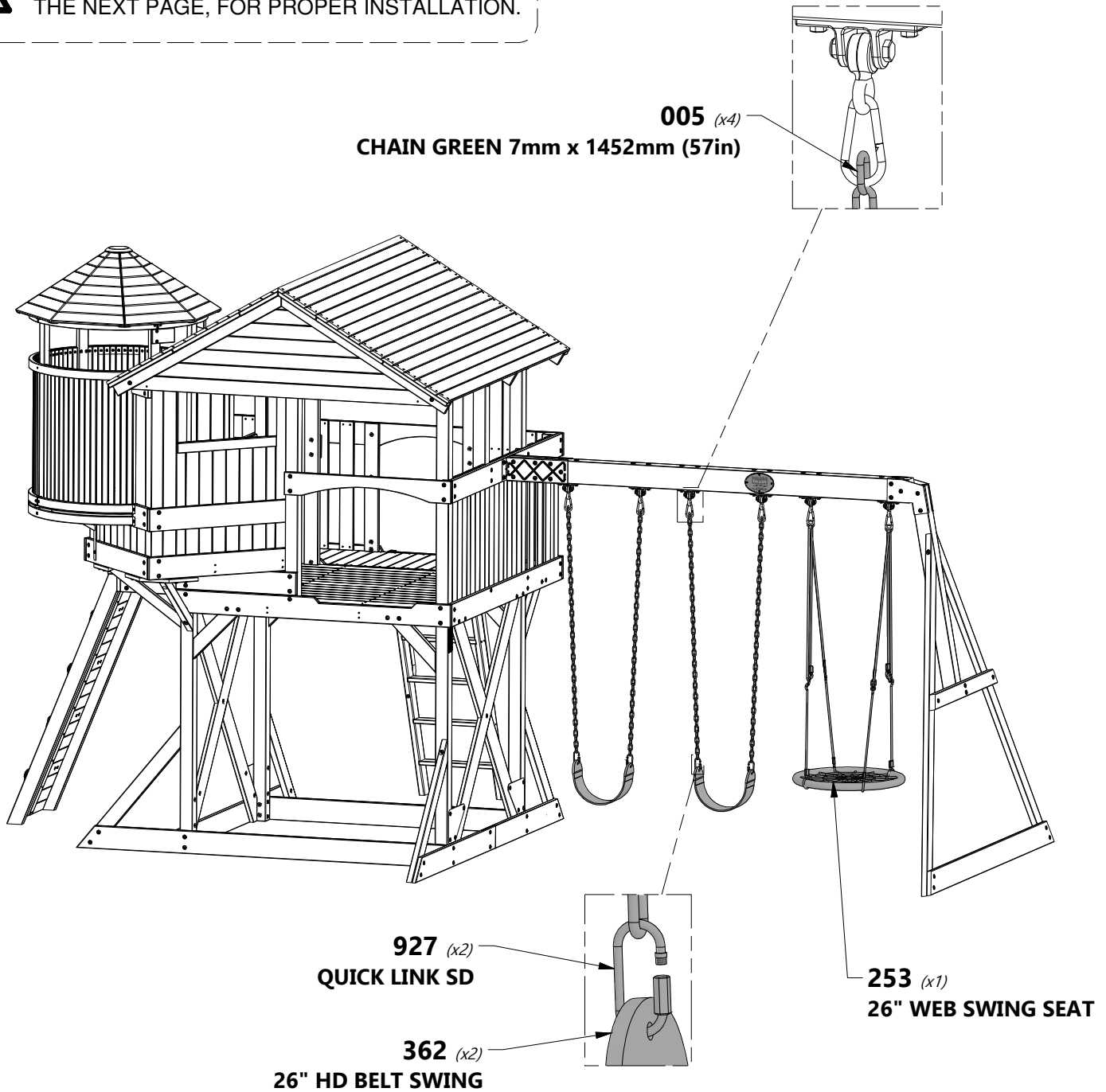

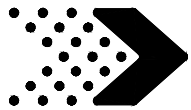

WEB SWING SETUP INSTRUCTIONS:

FOLLOW INSTRUCTIONS BELOW BEFORE USING THE WEB SWING.



IMPORTANT:

SWING MUST BE SET AT A MINIMUM OF 8 INCHES OFF THE GROUND WHEN INSTALLED.



IMPORTANT:

TO ENSURE STRAIGHT SWINGING MOTION, ADJUST ALL (4) "S" BRACKETS UNTIL WEB SEAT IS LEVEL.

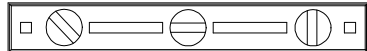

Note: It is important that the web swing hang level.



IMPORTANT:

MAKE SURE THE (4) LOOPS ARE IN A SYMMETRICAL PATTERN BEFORE SWINGING. (SEE BELOW).

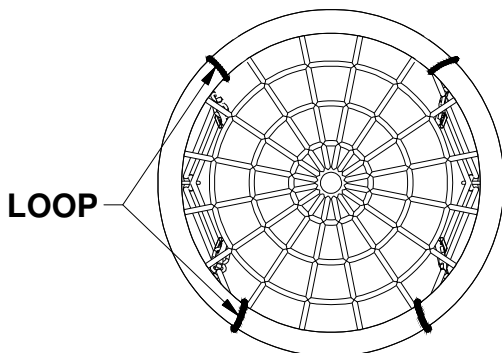
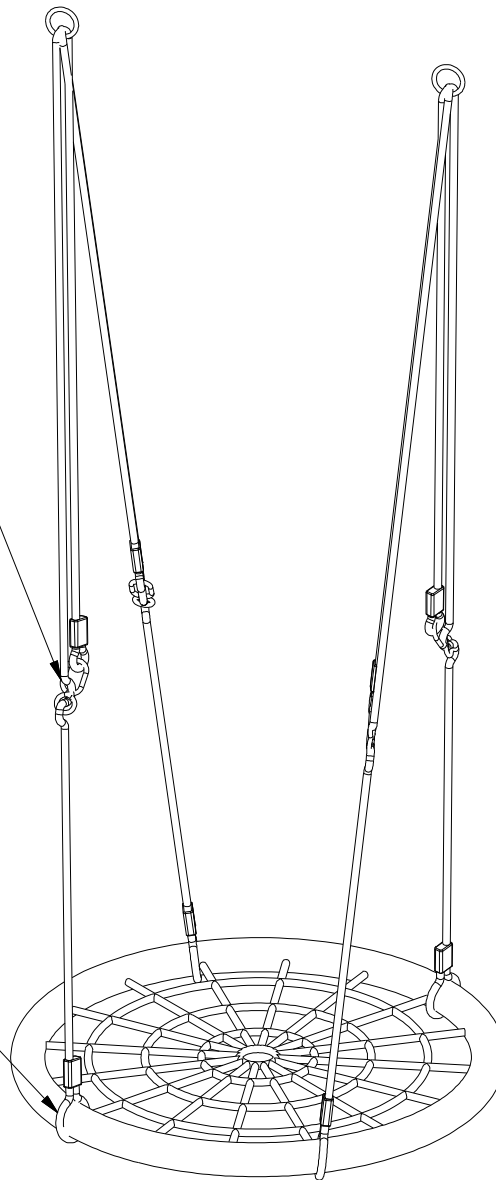
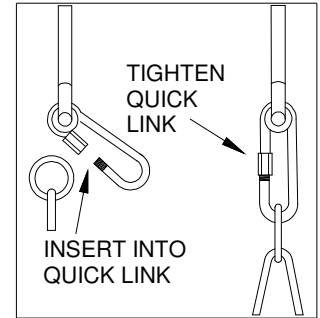

INCORRECT LOOP LOCATIONS (NON-SYMMETRICAL PATTERN)

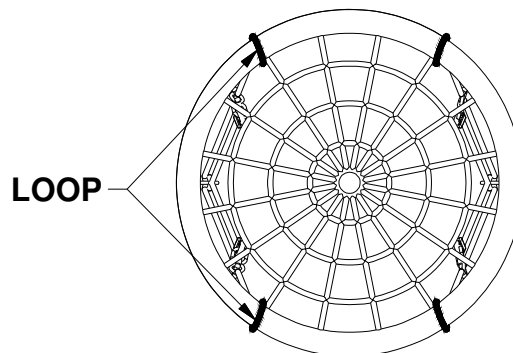

CORRECT LOOP LOCATIONS (SYMMETRICAL PATTERN)

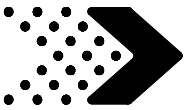

Phase 9

STEP 1

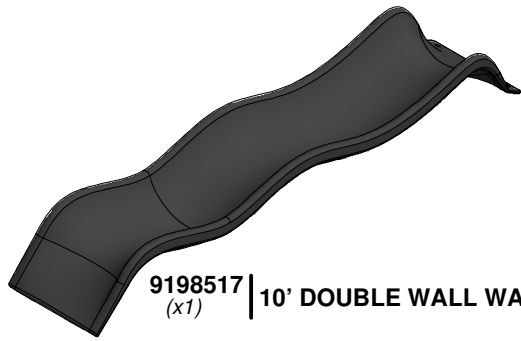

9198517 | 10' DOUBLE WALL WAVE SLIDE
(x1)



H100468 | BOLT WH BLK
(x3) | 5/16x1



H100379 | T-NUT BLK
(x3) | 5/16

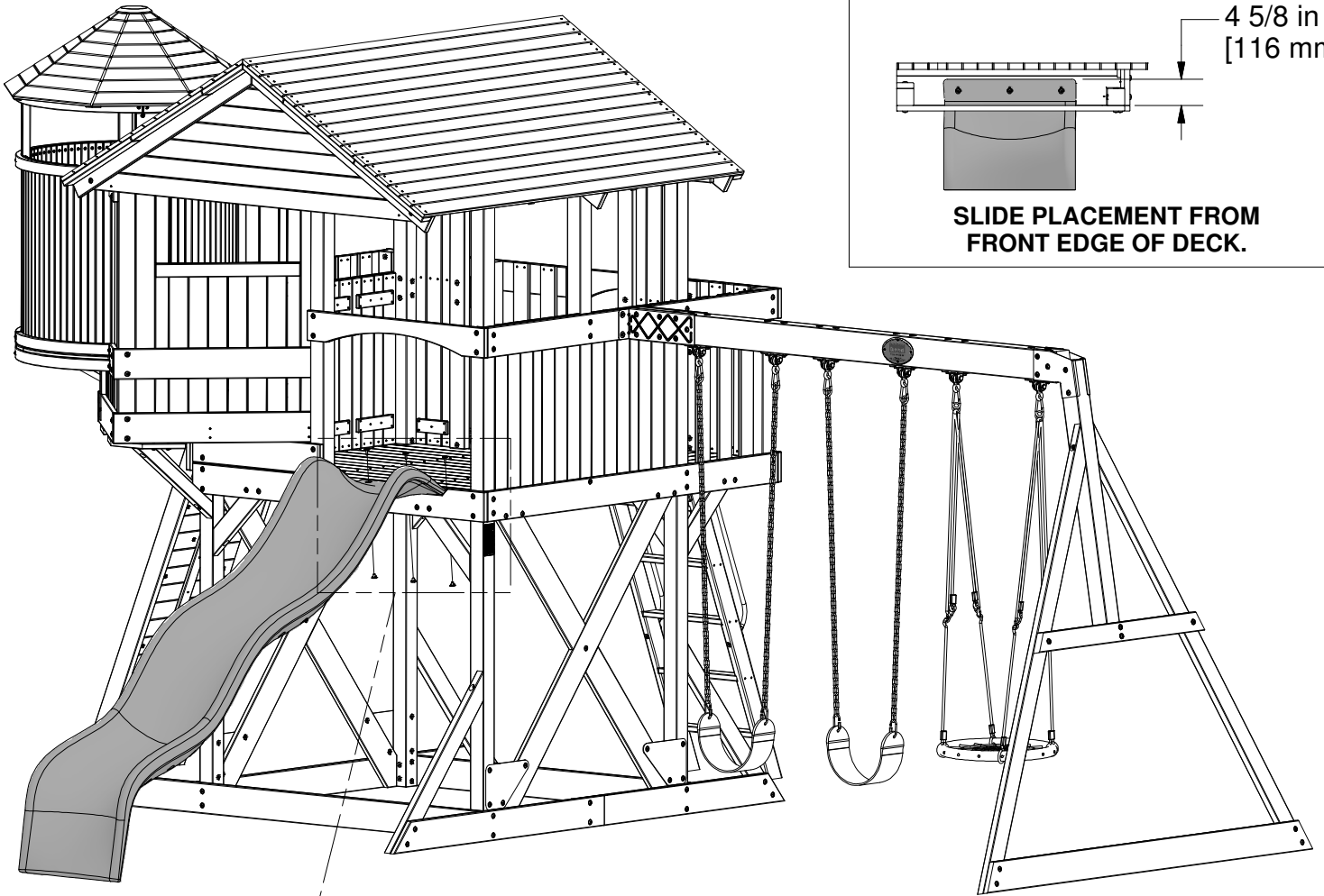

SLIDE PLACEMENT FROM FRONT EDGE OF DECK.

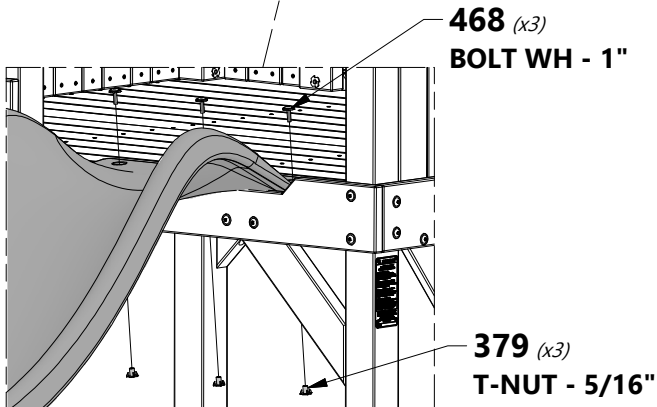

468 (x3)
BOLT WH - 1"

379 (x3)
T-NUT - 5/16"



NOTE:

1. CENTER THE SLIDE IN THE OPENING.
2. MARK THE HOLE LOCATIONS ON THE DECK SURFACE.
3. DRILL THROUGH THE DECK BOARDS USING A 3/8" OR 10mm DRILL BIT.
4. INSERT T-NUTS INTO THE BOTTOM OF THE DECK BOARDS AND TIGHTEN 3/4" BOLTS FROM THE TOP TO SECURE THE SLIDE IN PLACE.

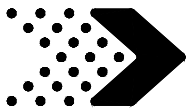

A100178 (x4) METAL GROUND STAKE BROWN



H100406 (x2) BOLT WH BLK 1/4x1 1/2



H100171 (x2) BOLT WH BLK 1/4x1



H100404 (x4) NUT BARREL WH BLK 1/4x5/8



H100474 (x4) WASHER FLAT BLK 9x18



H100400 (x4) WASHER LOCK EXT BLK 8x15



NOTE:
FAILURE TO USE GROUND STAKES CAN VOID WARRANTY AND CAUSE INJURY!

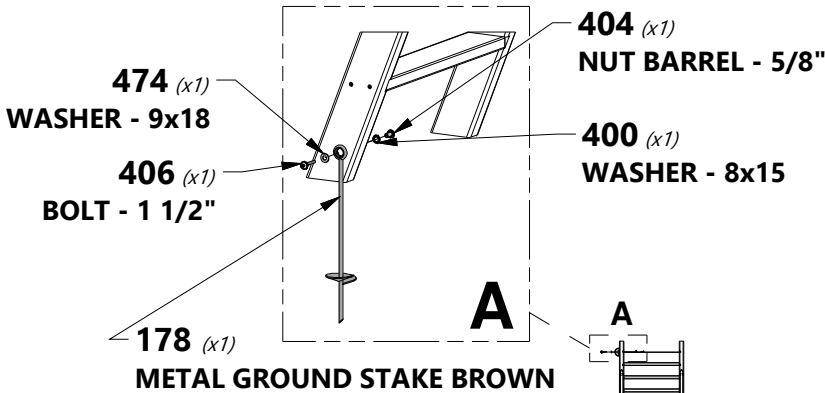

NOTE:

1. SCREW THE AUGER INTO THE GROUND NEXT TO THE GROUND BOARD.
2. USING THE EYELET OF THE AUGER AS A TEMPLATE, DRILL A 5/16" [8 mm] HOLE THROUGH THE GROUND BOARD.
3. USE HARDWARE PROVIDED TO SECURE AUGERS TO GROUND BOARDS.

