



MANUFACTURED BY:
Backyard Discovery
 3305 Airport Drive, Pittsburg, KS 66762
 800-856-4445

Basepoint Business Centre: Rivermead Drive, Westlea, Swindon SN5 7EX Phone: 0800-118-2476
 J.P. Coenstraat 7, The Bridge, The Hague, 2595 WP, Netherlands Phone: 0800-567-8990

CANYON CREEK CEDAR HAVEN

Swing Set

Model # 1803022 & 2200272

The assembly manual must be retained
 since it contains important information



WARNING
Adult Assembly Required.
 Not suitable for children under 36 months due to small parts.
FOR DOMESTIC USE ONLY. INTENDED FOR OUTDOOR USE.



Please visit www.backyarddiscovery.com

For the most up to date assembly manual, to register your set, or to order replacement parts
Para obtener instrucciones en español, visite www.backyarddiscovery.com



**EASY STEP-BY-STEP
 3D INTERACTIVE INSTRUCTIONS**
 DOWNLOAD THE FREE APP



**INSTALLATION
 SERVICES
 AVAILABLE!**
See inside for details

Made in China

INS-1803022-A-CANYON CREEK-ENG 2-8-2022
 INS-2200272-A-CEDAR HAVEN-ENG 2-8-2022

Owner's Manual - Basic Setup Dimensions & Assembly Notes

Place the set on level ground, not less than 6'-7" [2 m] from any structure or obstruction such as a fence, garage, house, overhanging branches, laundry lines, or electrical wires.

- While assembling unit, take time before and after each phase to make sure fort is level. If fort is not level, assembly will be difficult and improper assembly may result. Extra care must be taken to insure the fort is square.
- The safe play area refers to a zone extending 6'-7" (2 m) beyond the play product on all sides, including the space above the play product.

SAFE PLAY AREA DIAGRAM

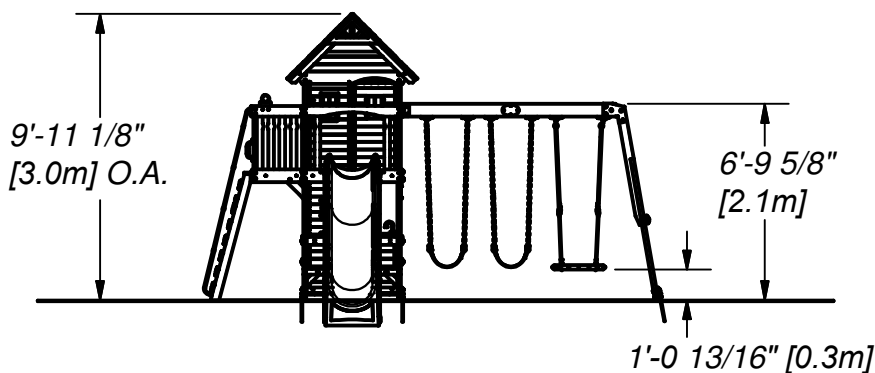
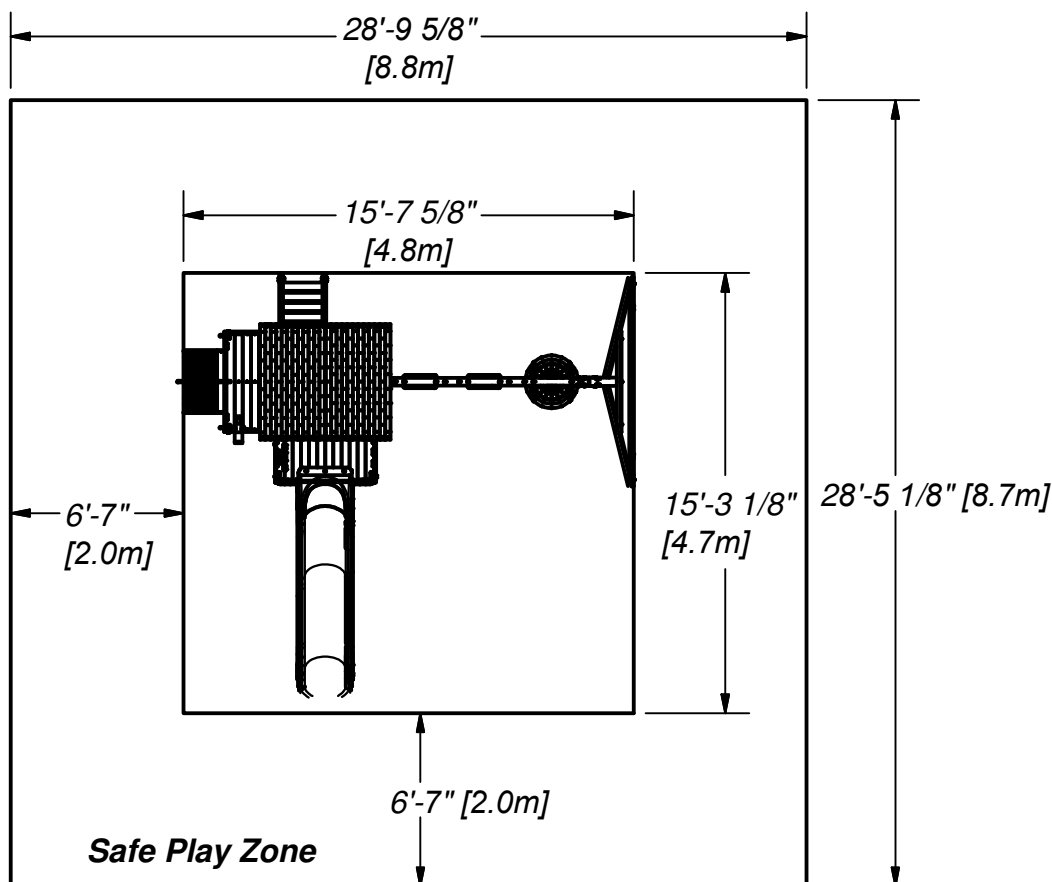

General Information:

Your set has been designed and engineered for children only and for residential use only.
A maximum of 150 lbs. per child is recommended for play activities designed for individual use.
A maximum of 120 lbs. per child is recommended for play activities designed for multiple child use.
A maximum of 9 children is recommended for this swing set.

Parts Identification

Wood Components

(NOT TO SCALE)



(1) **A74 - HEAVY DUTY SWING BEAM EXT. WEB SWING - W4L11647**
3 3/8"x5 1/4"x89 1/2" (86x134x2274)



(1) **E1 - RIGHT REAR UPRIGHT - W2A02496**
1 3/8"x3 3/8"x51 3/4" (36x86x1314)



(1) **E2 - LEFT REAR UPRIGHT - W4L11117**
1 3/8"x3 3/8"x51 3/4" (36x86x1314)



(1) **E3 - LEFT FRONT UPRIGHT - W4L11118**
1 3/8"x3 3/8"x51 3/4" (36x86x1314)



(1) **E4 - RIGHT FRONT UPRIGHT - W4L11119**
1 3/8"x3 3/8"x51 3/4" (36x86x1314)



(1) **E5 - RIGHT FRONT BALCONY UPRIGHT - W4L11126**
1 3/8"x3 3/8"x80 3/4" (36x86x2052)



(1) **E6 - LEFT REAR UPRIGHT - W4L11133**
1 3/8"x3 3/8"x43 1/2" (36x86x1104)

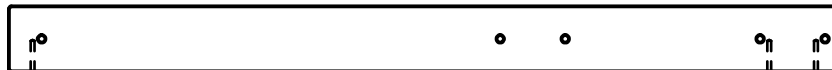

(1) **E7 - RIGHT REAR UPRIGHT - W4L11134**
1 3/8"x3 3/8"x43 1/2" (36x86x1104)

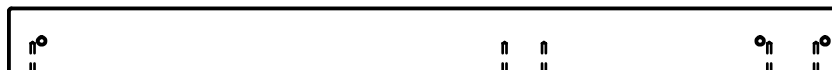

(1) **E8 - LEFT FRONT UPRIGHT - W4L11135**
1 3/8"x3 3/8"x43 1/2" (36x86x1104)

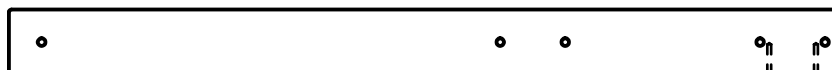

(1) **E9 - RIGHT FRONT UPRIGHT - W4L11136**
1 3/8"x3 3/8"x43 1/2" (36x86x1104)



(2) **E10 - MOUNTING BLOCK - W4L11155**
1 3/8"x3"x4 3/4" (36x76x120)

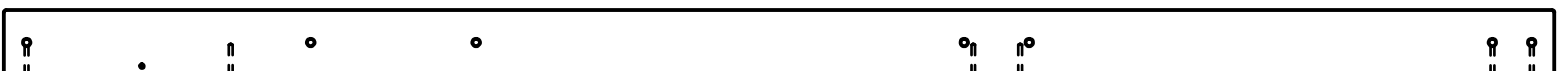

(1) **E11 - RIGHT FRONT BALCONY UPRIGHT - W4L11157**
1 3/8"x3 3/8"x80 3/4" (36x86x2052)

Parts Identification

Wood Components

(NOT TO SCALE)

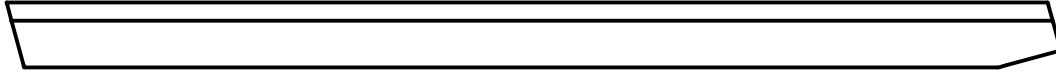

(1) E72 - LEFT RAIL - W4L11168
1 3/8"x3 3/8"x54 7/8" (36x86x1395)

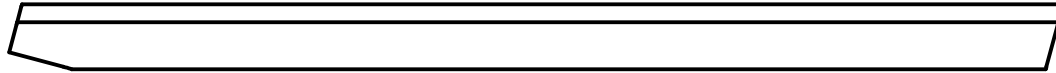

(1) E73 - RIGHT RAIL - W4L11169
1 3/8"x3 3/8"x54 7/8" (36x86x1395)



(2) E77 - ANGLE BRACE - W4L11648
1 3/8"x3 3/8"x73 1/8" (36x86x1859)

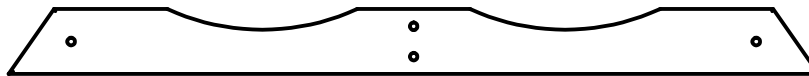

(1) E79 - END SUPPORT - W4L11650
1 1/2"x3 1/2"x42" (36x86x1072)



(1) F1 - RIGHT BALCONY UPRIGHT - W4L11130
1 3/8"x2 3/8"x31 3/4" (36x60x805)



(1) F2 - LEFT BALCONY UPRIGHT - W4L11131
1 3/8"x2 3/8"x31 3/4" (36x60x805)



(1) F3 - SUPPORT BLOCK - W4L11159
1 3/8"x2 3/8"x9 1/4" (36x60x234)



(1) F4 - SUPPORT BLOCK - W4L11160
1 3/8"x2 3/8"x9 1/4" (36x60x234)



(1) G1 - SWING BEAM MOUNT - W4L11137
1"x5 1/4"x62 1/8" (24x134x1577)



(1) G80 - GROUND BOARD - W4L11649
1"x5 1/4"x87 3/8" (24x134x2218)

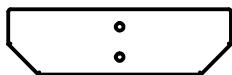

(1) H2 - TABLE SUPPORT - W4L11148
1"x3 3/8"x11 5/8" (24x86x295)

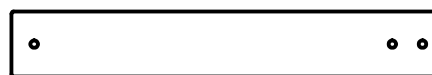

(1) H1 - TABLE SUPPORT - W4L11147
1"x3 3/8"x22 3/8" (24x86x567)



(4) H4 - DECK BRACE - W4L11156
1"x3 3/8"x12 3/4" (24x86x325)

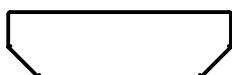

(1) H3 - TABLE SUPPORT - W4L11149
1"x3 3/8"x11 5/8" (24x86x295)

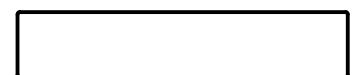

(4) H76 - LADDER RUNG - W4L07620
1"x3 3/8"x17 1/4" (24x86x437)

Parts Identification

Wood Components

(NOT TO SCALE)



- (1) **H77 - LEFT UPRIGHT - W4L11173**
1"x3 3/8"x58" (24x86x1474)



- (1) **H78 - RIGHT UPRIGHT - W4L11174**
1"x3 3/8"x58" (24x86x1474)



- (1) **J1 - PORCH GROUND BOARD - W4L11128**
1"x2 3/8"x40 1/2" (24x60x1030)



- (1) **J2 - PORCH GROUND BOARD - W4L11129**
1"x2 3/8"x40 5/8" (24x60x1032)



- (2) **J3 - BENCH SUPPORT - W4L11150**
1"x2 3/8"x9" (24x60x230)



- (2) **J4 - ANGLE BRACE - W4L11151**
1"x2 3/8"x10" (24x60x254)



- (2) **J5 - SUPPORT BLOCK - W4L11152**
1"x2 3/8"x2 7/8" (24x60x72)



- (2) **J6 - SUPPORT BLOCK - W4L11153**
1"x2 3/8"x6 1/4" (24x60x160)



- (1) **J7 - SUPPORT BLOCK - W4L11158**
1"x2 3/8"x3 3/8" (24x60x86)



- (1) **J8 - FLOOR JOIST - W4L07602**
1"x2 3/8"x40 1/2" (24x60x1029)

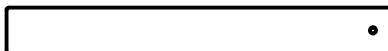

- (1) **J9 - FLOOR JOIST - W4L07603**
1"x2 3/8"x20 1/4" (24x60x513)

Parts Identification

Wood Components

(NOT TO SCALE)

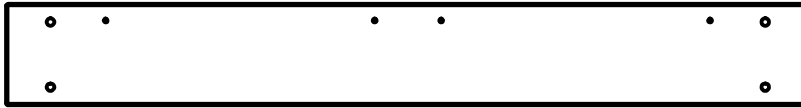

(1) **K1 - GROUND BOARD - W4L11113**
5/8"x5 1/4"x41 7/8" (16x134x1064)

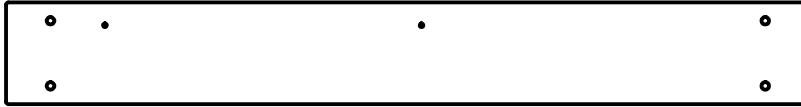

(1) **K2 - GROUND BOARD - W4L11114**
5/8"x5 1/4"x41 7/8" (16x134x1064)

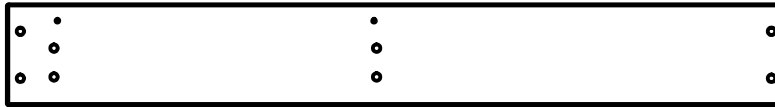

(1) **K3 - GROUND BOARD - W4L11115**
5/8"x5 1/4"x40 1/2" (16x134x1030)

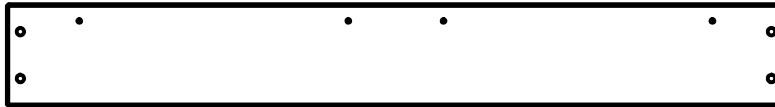

(1) **K4 - GROUND BOARD - W4L11116**
5/8"x5 1/4"x40 1/2" (16x134x1030)



(1) **K5 - RIGHT CENTER WALL RAIL - W4L11120**
5/8"x5 1/4"x62 3/4" (16x134x1593)



(1) **K6 - FRONT CENTER WALL RAIL - W4L11121**
5/8"x5 1/4"x61 3/8" (16x134x1560)

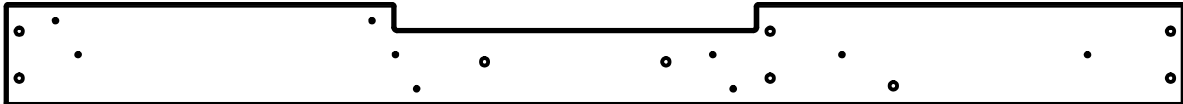

(1) **K7 - REAR CENTER WALL RAIL - W4L11122**
5/8"x5 1/4"x61 3/8" (16x134x1560)

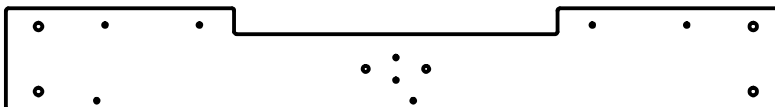

(1) **K8 - LEFT CENTER WALL RAIL - W4L11123**
5/8"x5 1/4"x40 5/8" (16x134x1032)

Parts Identification

Wood Components

(NOT TO SCALE)



(1) **K9 - LEFT BALCONY WALL RAIL - W4L11124**
5/8"x5 1/4"x20 3/4" (16x134x528)

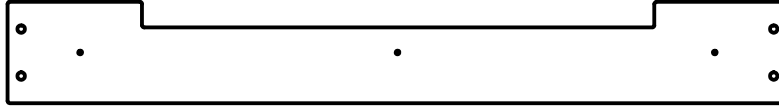

(1) **K10 - FRONT BALCONY WALL RAIL - W4L11125**
5/8"x5 1/4"x40 5/8" (16x134x1032)

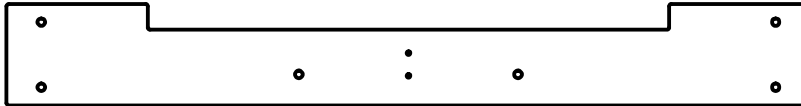

(1) **K11 - LEFT SIDE WALL BOARD - W4L11132**
5/8"x5 1/4"x41 7/8" (16x134x1064)



(1) **K12 - ARCHED WALL RAIL - W4L11143**
5/8"x5 1/4"x40 5/8" (16x134x1032)



(1) **K13 - ARCHED WALL RAIL - W4L11144**
5/8"x5 1/4"x40 5/8" (16x134x1032)

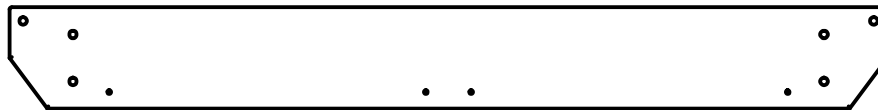

(1) **K14 - ANGLED WALL RAIL - W4L11145**
5/8"x5 1/4"x45 3/4" (16x134x1162)

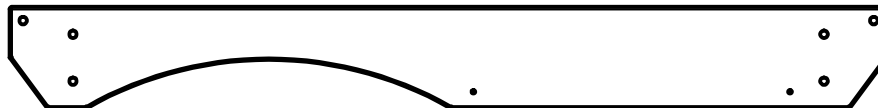

(1) **K15 - ANGLED WALL RAIL - W4L11146**
5/8"x5 1/4"x45 3/4" (16x134x1162)

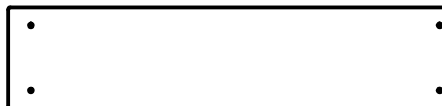

(1) **K16 - TABLE BOARD - W4L07594**
5/8"x5 1/4"x23" (16x134x583)

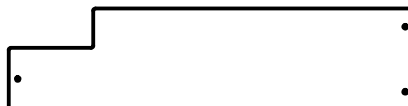

(2) **K17 - FLOOR BOARD - W4L07596**
5/8"x5 1/4"x21 1/8" (16x134x537)

Parts Identification

Wood Components

(NOT TO SCALE)



(1) **L1 - ARCHED WALL RAIL - W4L11138**
5/8"x4 3/8"x40 5/8" (16x112x1032)



(1) **L2 - WALL RAIL - W4L11139**
5/8"x4 3/8"x23 1/4" (16x112x590)

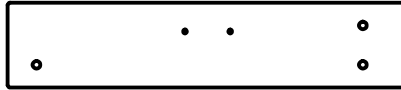

(1) **L3 - WALL RAIL - W4L11140**
5/8"x4 3/8"x20 7/8" (16x112x529)

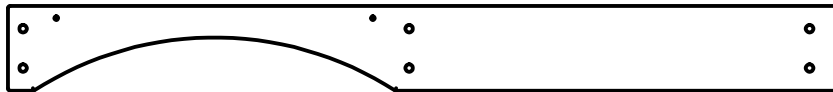

(1) **L4 - ARCHED WALL RAIL - W4L11141**
5/8"x4 3/8"x43 3/8" (16x112x1103)



(2) **L5 - GROUND BOARD - W4L11652**
5/8"x4 3/8"x24 1/8" (16x112x612)

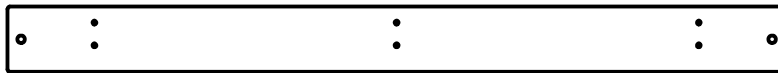

(1) **M1 - WALL RAIL - W4L11154**
5/8"x3 3/8"x40 1/2" (16x86x1030)



(2) **M2 - BENCH BOARD - W4L07591**
5/8"x3 3/8"x23" (16x86x583)

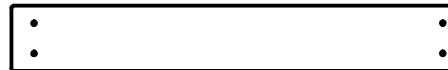

(4) **M3 - TABLE BOARD - W4L07593**
5/8"x3 3/8"x23" (16x86x583)



(8) **M4 - FLOOR BOARD - W4L07597**
5/8"x3 3/8"x21 1/8" (16x86x537)

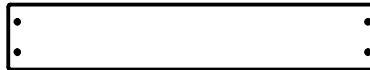

(1) **M5 - FLOOR BOARD - W4L07598**
5/8"x3 3/8"x19 1/4" (16x86x488)



(1) **M6 - COUNTER TOP - W4L07605**
5/8"x3 3/8"x37 5/8" (16x86x957)



(2) **M7 - COUNTER TOP - W4L07606**
5/8"x3 3/8"x38 5/8" (16x86x981)

Parts Identification

Wood Components

(NOT TO SCALE)



- (1) **M8 - FLOOR BOARD - W4L07607**
5/8"x3 3/8"x20 1/8" (16x86x512)



- (10) **M9 - FLOOR BOARD - W4L07608**
5/8"x3 3/8"x20 1/8" (16x86x512)

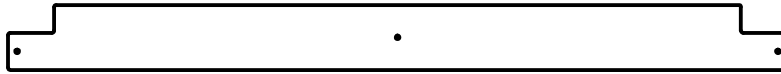

- (1) **M10 - FLOOR BOARD - W4L07609**
5/8"x3 3/8"x40 5/8" (16x86x1031)



- (15) **M11 - FLOOR BOARD - W4L07610**
5/8"x3 3/8"x40 5/8" (16x86x1031)



- (2) **M12 - FLOOR BOARD - W4L07611**
5/8"x3 3/8"x40 5/8" (16x86x1031)



- (1) **M13 - FLOOR BOARD - W4L07671**
5/8"x3 3/8"x20 1/8" (16x86x512)



- (1) **M73 - REAR SUPPORT - W4L07619**
5/8"x3 3/8"x18 1/4" (16x86x465)



- (7) **M74 - ROCK WALL BOARD - W4L07624**
5/8"x3 3/8"x25" (16x86x635)



- (4) **M75 - ROCK WALL BOARD - W4L07627**
5/8"x3 3/8"x25" (16x86x635)



- (4) **M76 - ROCK WALL BOARD - W4L07626**
5/8"x3 3/8"x25" (16x86x635)

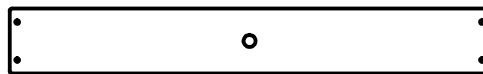

- (1) **M77 - ROCK WALL BOARD - W4L11171**
5/8"x3 3/8"x25" (16x86x635)

Parts Identification

Wood Components

(NOT TO SCALE)



- (1) **M102 - ATTACHMENT BOARD - W4L11167**
5/8"x3 3/8"x26 1/4" (16x86x667)



- (1) **M108 - TOP BOARD - W4L11170**
5/8"x3 3/8"x26 1/4" (16x86x667)



- (1) **M110 - ATTACHMENT BOARD - W4L11172**
5/8"x3 3/8"x18 1/4" (16x86x465)



- (2) **N1 - PORCH GROUND BOARD - W4L11127**
5/8"x2 3/8"x21 1/8" (16x60x537)



- (18) **N2 - PICKET - W4L07612**
5/8"x2 3/8"x24 3/4" (16x60x628)



- (2) **N3 - BENCH BOARD - W4L07592**
5/8"x2 3/8"x23" (16x60x583)



- (1) **O70 - SLIDE MOUNTING BOARD - W4L09040**
5/8"x1 3/8"x20 3/8" (16x34x517)

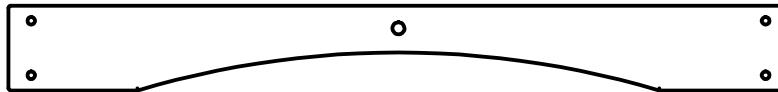

- (1) **Q1 - ARCHED WALL RAIL - W4L11142**
1"x4 3/8"x40 5/8" (24x112x1032)

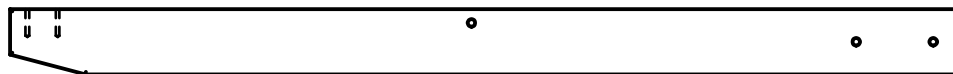

- (1) **SP1 - SWING BEAM SUPPORT - W4L11651**
3 3/8"x3 3/8"x49 5/8" (86x86x1260)

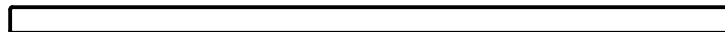

- (3) **T1 - SUPPORT BOARD - W4L07599**
1"x1 3/8"x37 5/8" (24x34x957)



- (1) **T2 - SUPPORT BOARD - W4L07600**
1"x1 3/8"x37 3/4" (24x34x959)



- (2) **T3 - SUPPORT BOARD - W4L07601**
1"x1 3/8"x18 3/4" (24x34x477)

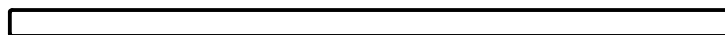

- (1) **T4 - SUPPORT BOARD - W4L07613**
1"x1 3/8"x37 3/4" (24x34x958)

Parts Identification

Wood Components

(NOT TO SCALE)

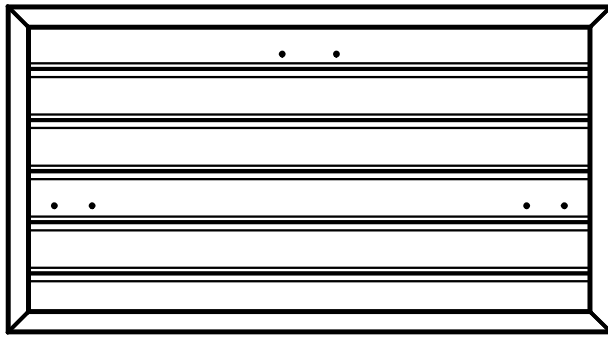

(1) WP1 - FRONT WALL PANEL - W2A02082
1"x20 3/8"x37 3/4" (24x517x958)

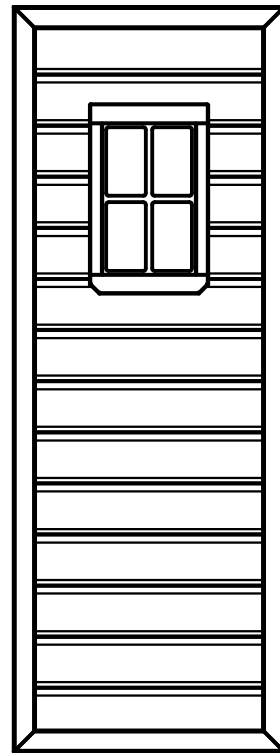

(2) WP2 - RIGHT LOWER WALL PANEL - W2A02083
1"x16 7/8"x46 1/2" (24x430x1181)

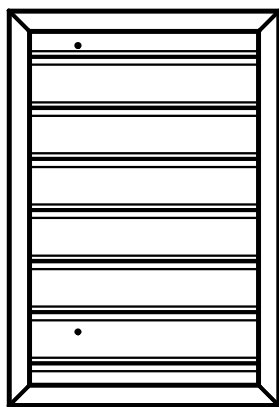

(1) WP3 - TOP RIGHT FRONT WALL PANEL - W2A02497
1"x16 7/8"x24 5/8" (24x430x627)

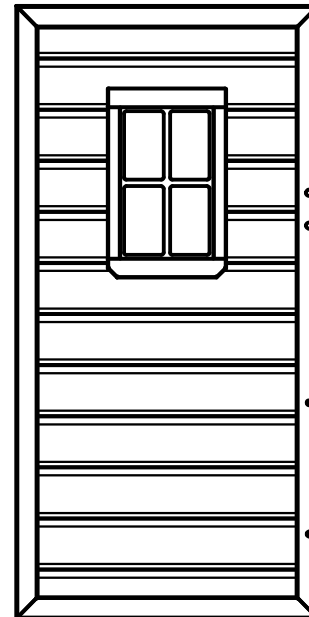

(1) WP4 - TOP RIGHT FRONT WALL PANEL - W2A02498
1"x16 7/8"x24 5/8" (24x430x627)

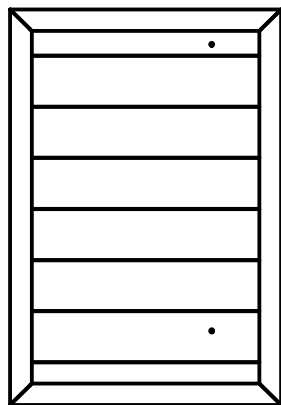

(1) WP5 - TOP LEFT REAR WALL PANEL - W2A02086
1"x16 7/8"x46 1/2" (24x430x971)

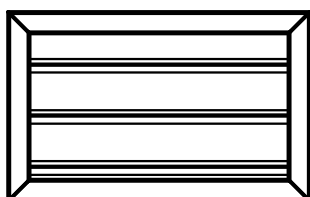

(1) WP6 - TOP REAR WALL PANEL - W2A02087
1"x18 7/8"x11 3/4" (24x479x300)

Parts Identification

Wood Components

(NOT TO SCALE)

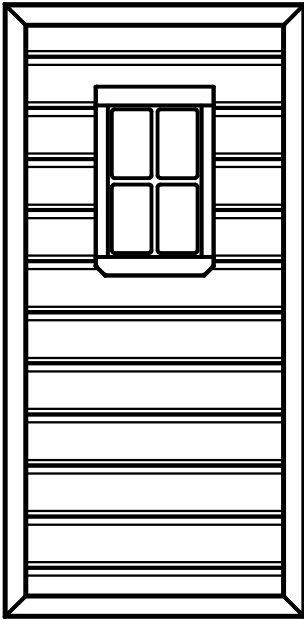

(1) WP7 - TOP FRONT WALL PANEL - W2A02088
1"x16 7/8"x38 1/4" (24x476x971)

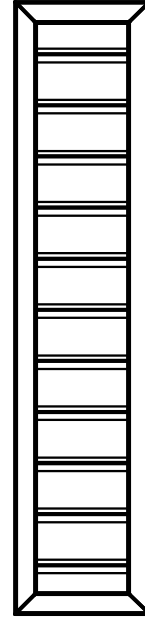

(2) WP8 - TOP LEFT WALL PANEL - W2A02089
1"x11 3/4"x38 1/4" (24x214x971)

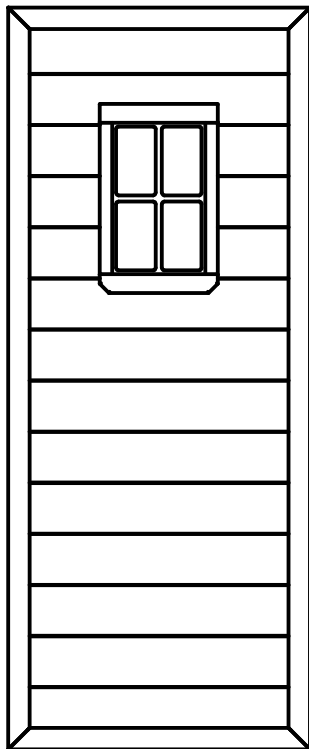

(2) WP9 - LOWER WALL PANEL - W2A02090
1"x18 7/8"x46 1/4" (24x479x1176)

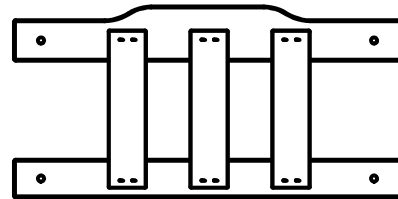

(2) WP10 - BENCH BACK ASSEMBLY - W2A02081
1 1/8"x11 7/8"x17 5/8" (27x303x615)

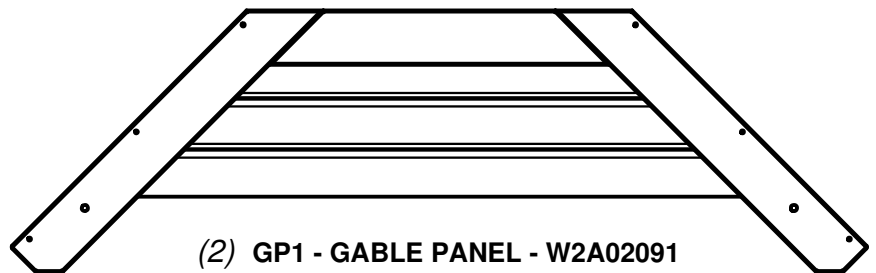

(2) GP1 - GABLE PANEL - W2A02091
1 1/8"x53 1/2"x16 3/8" (27x1359x414)

Parts Identification

Wood Components

(NOT TO SCALE)

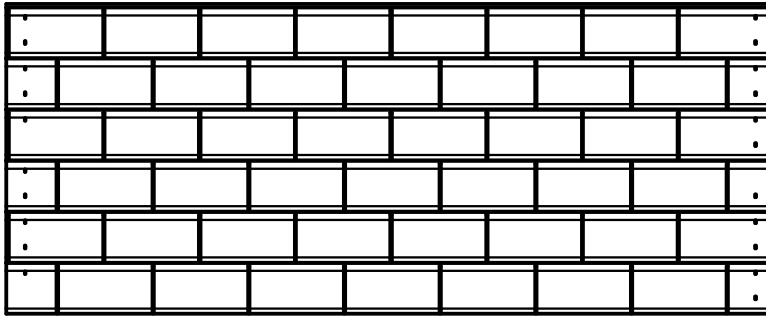

(2) RP1 - BOTTOM ROOF PANEL - W2A02494
1 3/8"x48"x19 3/8" (35x1220x491)

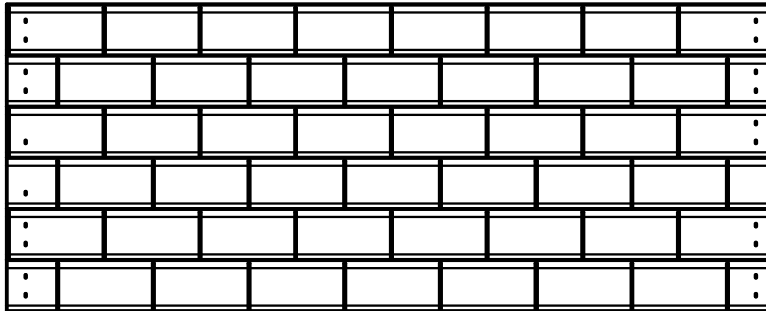

(2) RP2 - TOP ROOF PANEL - W2A02495
1 3/8"x48"x19 1/8" (35x1220x486)

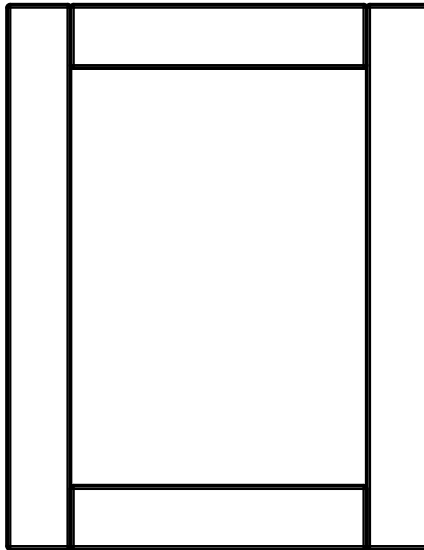

(1) - CHALKBOARD - A4M00906

Parts Identification

Hardware



(86) - SCREW PFH 8x1-1/8" - H100088



(7) - SCREW PFH 8x1-1/4" - H100087



(249) - SCREW PFH 8x1-1/2" - H100086



(13) - SCREW PFH 8x1-3/4" - H100089



(71) - SCREW PFH 8x1 1/4 BLK - H100387



(17) - SCREW PFH 8x1-1/2 BLK - H100200



(4) - SCREW PFH 8x1 3/4 BLK - H100382



(24) - SCREW PFH 8x2 BLK - H100391



(17) - SCREW PWH 8x5/8 - H100128



(9) - SCREW PWH 8x1-1/4 - H100180



(4) - SCREW PWH 8x1/2 BLK - H100408



(1) - BOLT WH 5/16X6 BLK - H100363



(6) - BOLT WH 5/16x3 BLK - H100416



(3) - BOLT WH 5/16x2-3/4 BLK - H100195



(13) - BOLT WH 5/16x2-1/4 BLK - H100205



(48) - BOLT WH 5/16x2 BLK - H100457



(4) - BOLT WH 5/16x1 3/4 BLK - H100378



(7) - BOLT WH 5/16x1 1/2 BLK - H100407



(9) - BOLT WH 5/16x1 1/4 BLK - H100459



(4) - BOLT WH 5/16x1 BLK - H100468



(18) - BOLT WH 5/16x1/2 BLK - H100396



(28) - T-NUT 1/4 - H100072



(2) - T-NUT 1/4 BLK - H100398

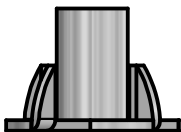

(3) - T-NUT 5/16 - H100074

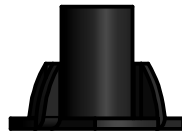

(79) - T-NUT 5/16 BLK - H100379

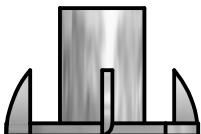

(13) - T-NUT 3/8 - H100073

Parts Identification

Hardware

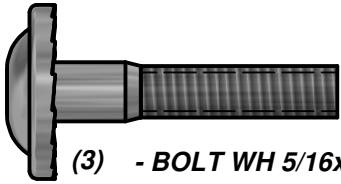

(3) - BOLT WH 5/16x1 1/2 - H100010

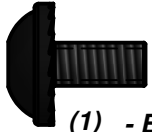

(1) - BOLT WH 1/4x1/2 BLK - H100401

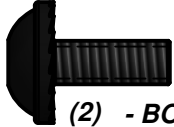

(2) - BOLT WH 1/4x5/8 BLK - H100486

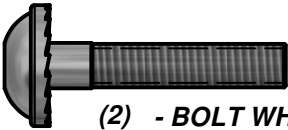

(2) - BOLT WH 1/4x1-1/4 - H100142

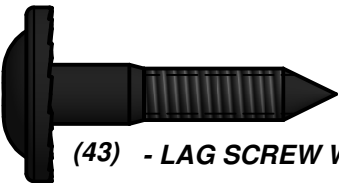

(43) - LAG SCREW WH 5/16x1 1/2 BLK - H100471



(7) - LAG SCREW WH 5/16x2 BLK - H100458



(4) - LAG SCREW WH 5/16x3 BLK - H100206

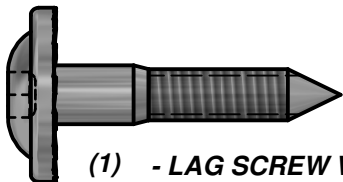

(1) - LAG SCREW WH 5/16x1 1/2 - H100026

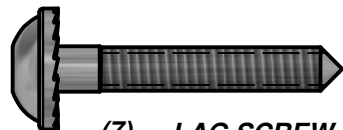

(7) - LAG SCREW WH 1/4x1-1/2 - H100145



(4) - LAG SCREW WH 1/4x1-1/2 BLK - H100403



(2) - LAG SCREW WH 1/4x2 BLK - H100487

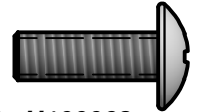

(26) - BOLT PTH 1/4x3/4 - H100063



(15) - NUT BARREL WH 5/16x5/8 BLK - H100469



(20) - NUT BARREL WH 5/16x7/8 BLK - H100192



(1) - NUT BARREL WH 1/4x7/8 BLK - H100399



(2) - BOLT HEX 5/16x4 1/4 BLK - H100476



(4) - BOLT HEX 5/16x1 1/4 BLK - H100481

Parts Identification

Hardware



(2) - NUT LOCK 5/16 BLK - H100479

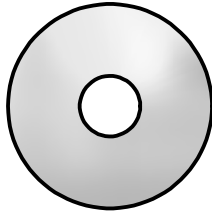

(1) - WASHER FLAT 8x27 - H100105

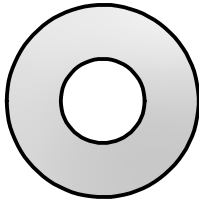

(13) - WASHER FLAT 11x25 - H100102

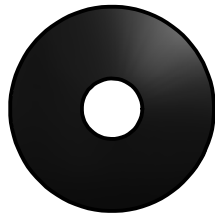

(9) - WASHER FLAT 8x27 BLK - H100478



(4) - WASHER SPLIT 5/16 BLK - H100477



(7) - WASHER LOCK EXT 6x15 BLK - H100405

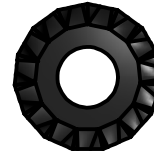

(137) - WASHER LOCK EXT 8x19 BLK - H100198



(29) - WASHER LOCK EXT 12x19 BLK - H100199

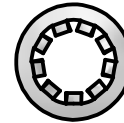

(26) - WASHER LOCK INT 8x15 - H100108

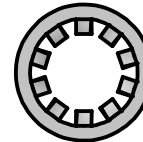

(13) - WASHER LOCK INT 10x18 - H100107

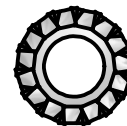

(9) - WASHER LOCK EXT 6x15 - H100138

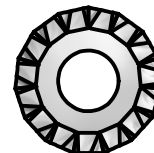

(3) - WASHER LOCK EXT 8x19 - H100030

Parts Identification

Hardware

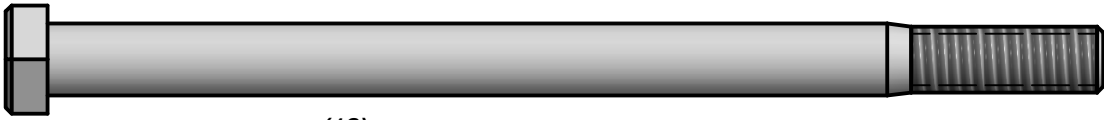

(13) - BOLT HEX 3/8x5-1/2 - H100654

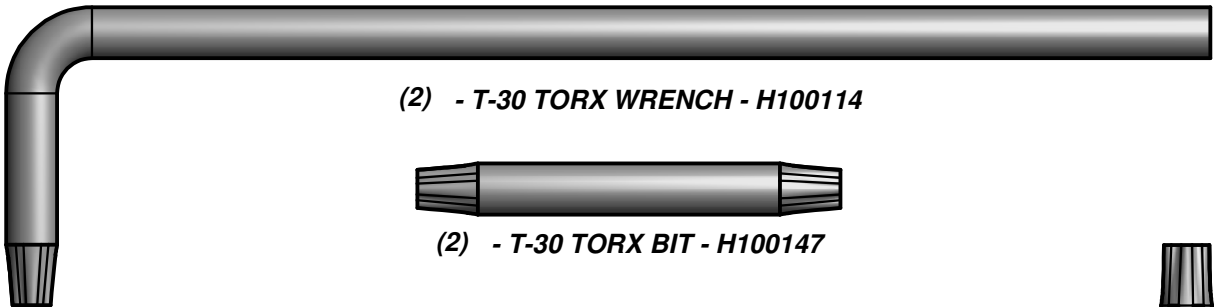

(2) - T-30 TORX WRENCH - H100114



(2) - T-30 TORX BIT - H100147



(2) - T-40 TORX BIT - A100042

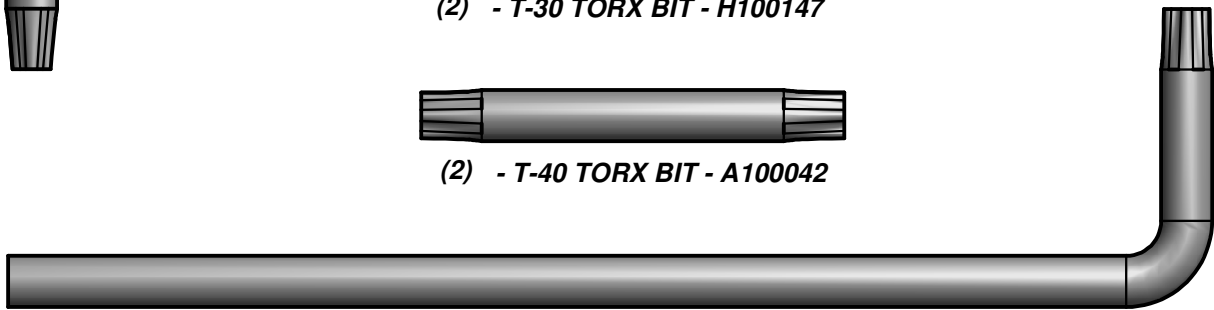

(2) - T-40 TORX WRENCH - A100041

Parts Identification

Accessories
(NOT TO SCALE)

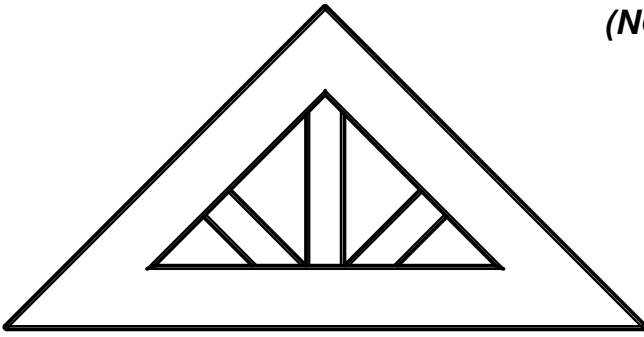

(2) SY - PLASTIC SUNBURST - A100322



(1) - BYD ID TAG (LARGE) AGES 3-10 - A100164



(1) QU - SLIDE VF 10 FT - A100287 OR 50250

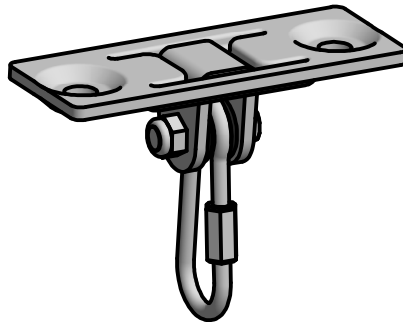

(6) BY - SWING HANGER QUICK LINK - A4M00505-3



(6) - GROUND STAKE REBAR - A4M00527



(4) - CHAIN GREEN 51.25" - A100068

Parts Identification

Accessories
(NOT TO SCALE)

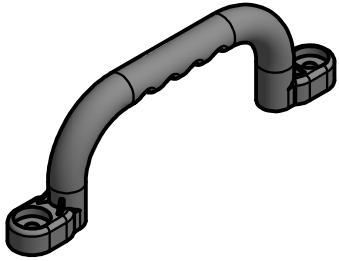

(4) DQ - HAND GRIP GREEN PLASTIC - A100028



(1) - "A" REVISION TAG - A100314

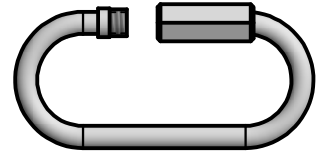

(4) FA - QUICK LINK - A100069

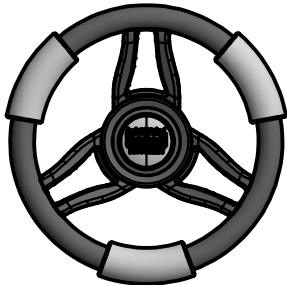

(1) LP - STEERING WHEEL - A100105

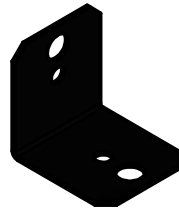

(2) - 90° L-BRACKET - BLK - A4M00555

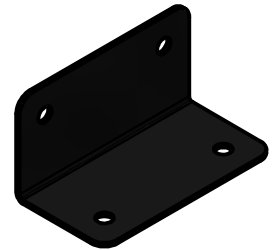

(2) - L BRACKET 66x66x127 - BLK - A4M00619

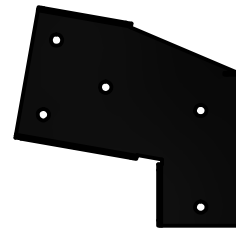
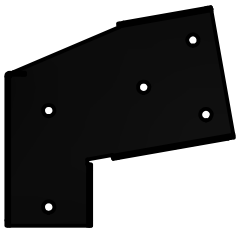

(1) - SWING BEAM EXTENSION BRACKET-LEFT - A4M00617

(1) - SWING BEAM EXTENSION BRACKET-RIGHT - A4M00618

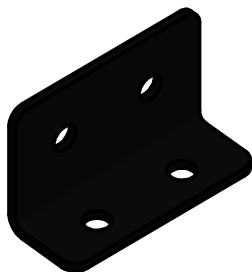

(2) - L BRACKET 51x32x82x3.175 - A4M00855

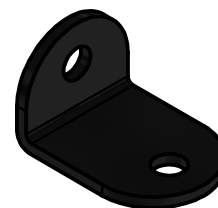

(2) - L BRACKET BLACK 32x51 - A4M00710

Parts Identification

Accessories
(NOT TO SCALE)

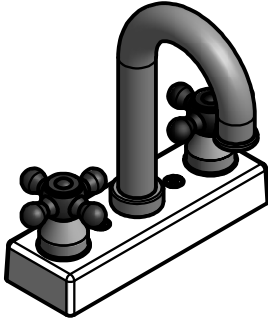

(1) - FAUCET KIT - A6P00024

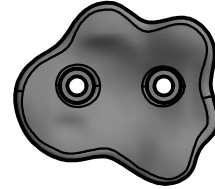

(3) - GREEN HC ROCK #1 - A6P00036

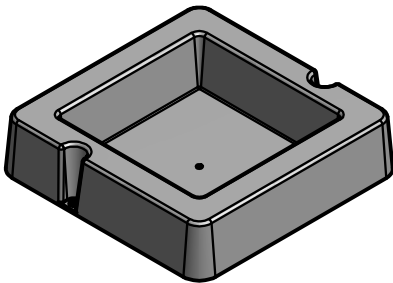

(1) - SURFACE MOUNT BASIN - A6P00032

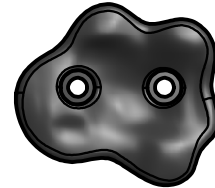

(3) - RED HC ROCK #1 - A6P00038

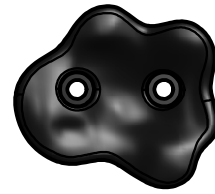

(3) - BLUE HC ROCK #2 - A6P00040

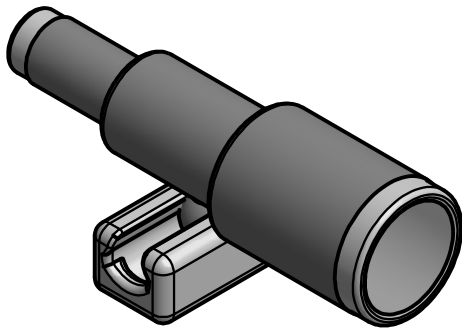

(1) LN - Telescope - A6P00096

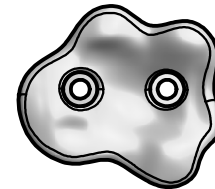

(3) - YELLOW HC ROCK #1 - A6P00042



(1) GRILL FOOD SET - 141154

Parts Identification

Accessories
(NOT TO SCALE)

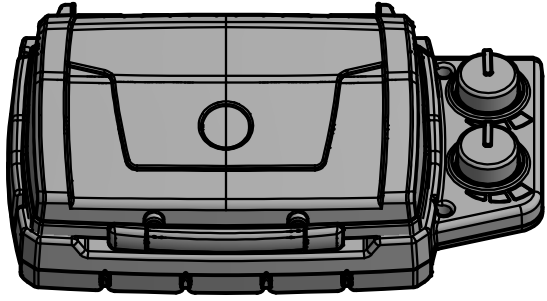

(1) GRILL - A6P00282



(1) - CLIMBING ROPE - A6P00260

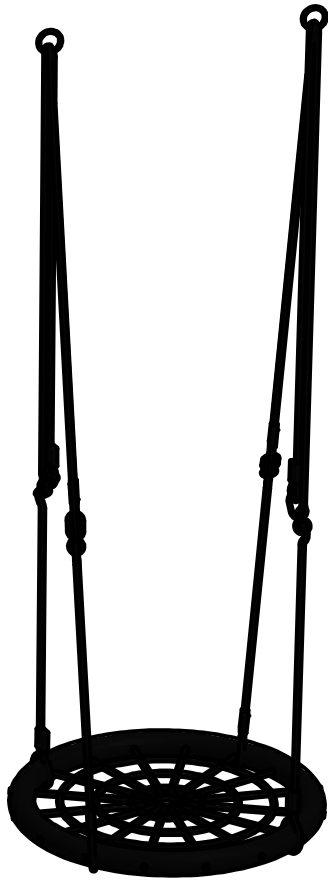

(1) - 21" WEB SWING SEAT - A6P00285

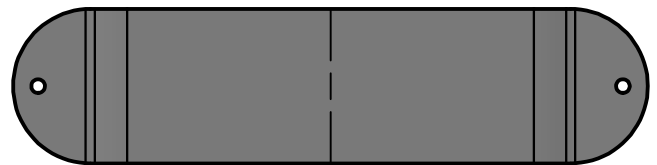

(2) - SWING SEAT GREEN 22IN - A6P00054

PRE-ASSEMBLY STEP 1 - SORTING PARTS

It is critical for ease of assembly that you take the time to sort and organize the wood and hardware.

WOOD PARTS:

- Organize wood parts by the three-digit, alpha-numeric number stamped on each board (ex. P01).
- If there are multiple boards with the same stamped number, stack those pieces together.
- Stamps can be found on the flat surface of the boards or on the end of the boards.
- Allow yourself plenty of room - the wood pieces can take up a significant amount of space.

NOTE: CARTONS ARE NOT ORGANIZED BY BOARD NUMBER.

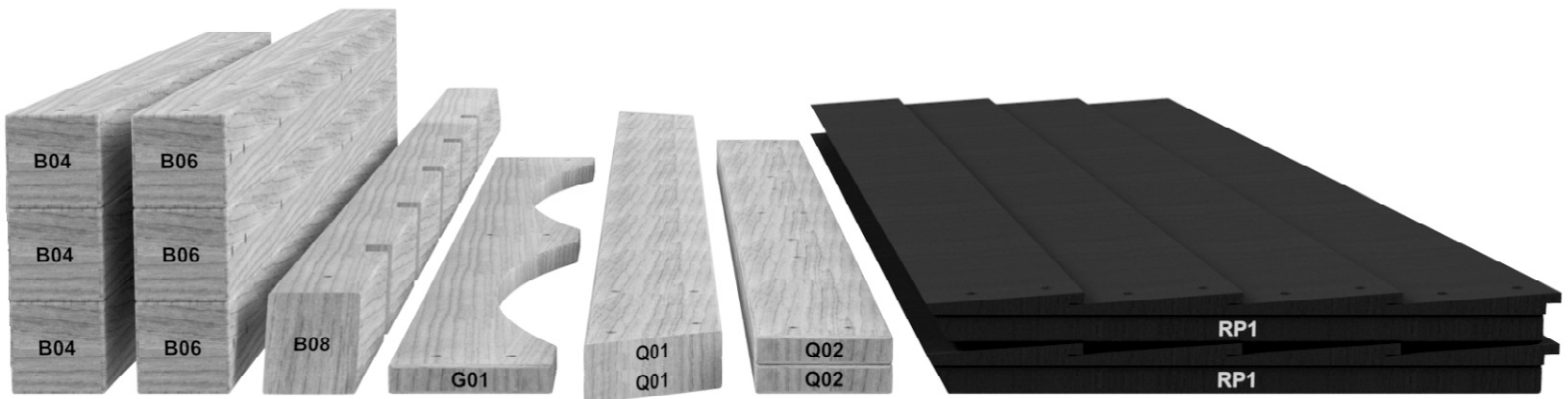

HARDWARE PARTS:

- We recommend that you have a separate table to organize the hardware.
- Hardware bags are printed with a seven-digit, alpha-numeric part number.
- You can organize your hardware by part number or group by hardware type (i.e. bolts, nuts, etc.).
- During assembly you only need to reference the last four digits of the number.

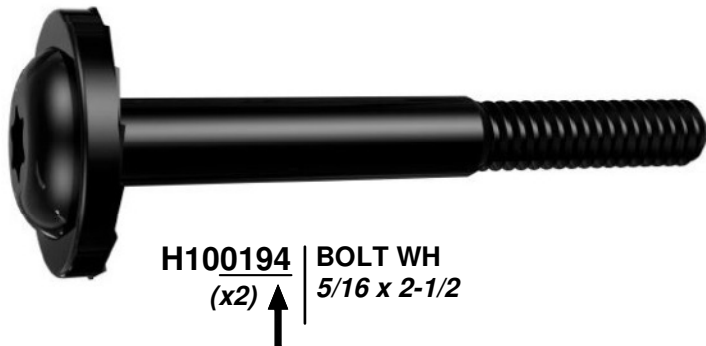

PRE-ASSEMBLY STEP 2 - TOOLS REQUIRED



**Cordless Drill or
Electric Drill**



**Drill Attachments:
Phillips Head**



**1/8", 3/16", 3/8" & 7/16"
Drill Bits**



Phillips Screw Driver



Open End Wrenches 1/2" & 9/16"



**3/8" Drive Ratchet, 1/2" &
9/16" STD Sockets 1/2" & 9/16" Deep
Sockets**



Claw Hammer



Rubber Mallet - Optional



Tape Measure

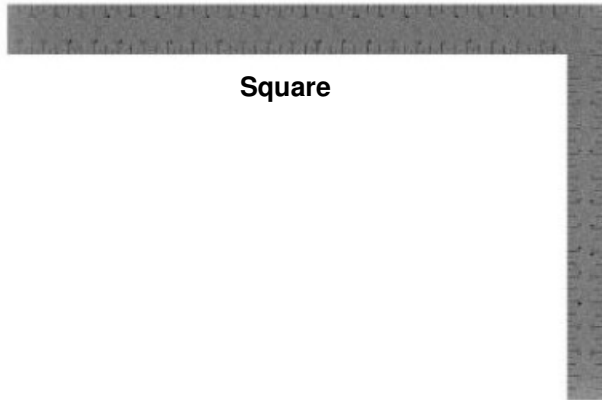

Square



Level 24"

PRE-ASSEMBLY STEP 3 - CHOOSE YOUR ASSEMBLY METHOD

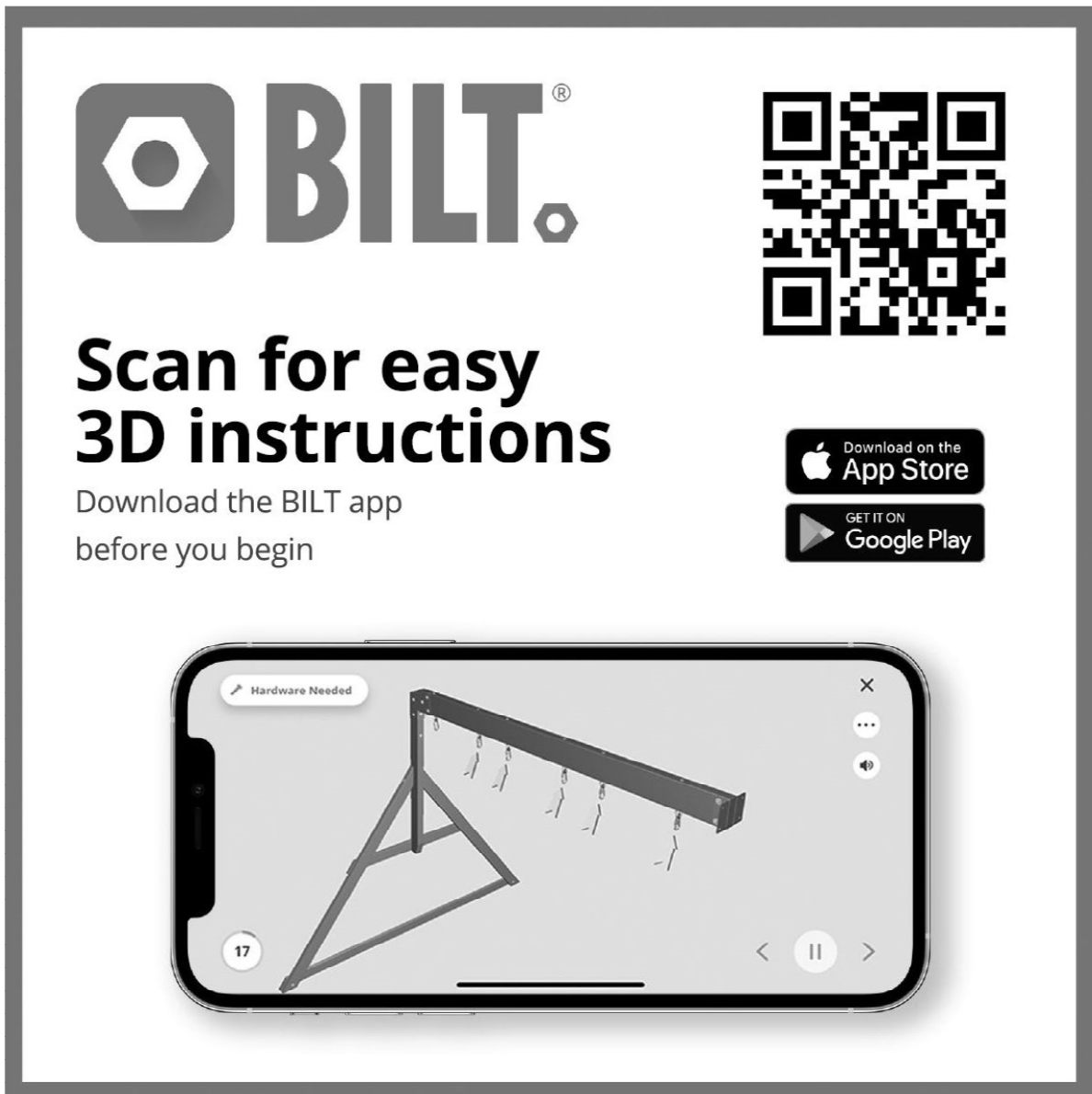

There are several types of assembly instructions available to you.

1. Printed Assembly Manual included with your set
2. BILT APP - 3D interactive instructions
3. Combination of the Printed Manual and BILT APP (Note: Step numbers can differ between the two methods)

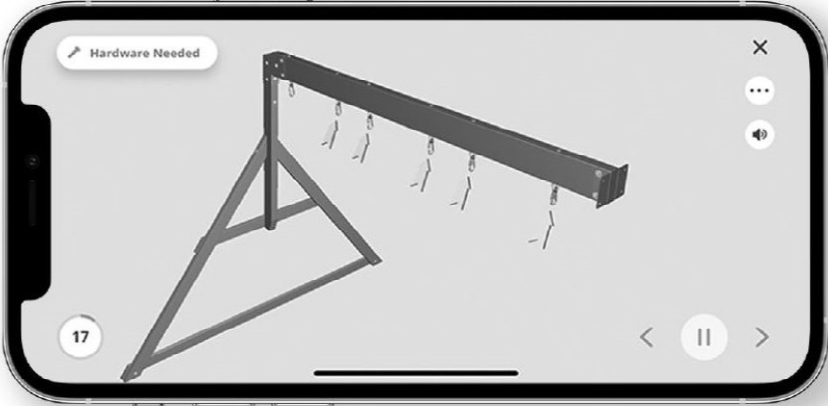

Scan for easy 3D instructions

Download the BILT app
before you begin



The image shows a smartphone screen displaying the BILT app interface. The screen features a 3D assembly diagram of a metal frame with a horizontal beam and several hanging components. The interface includes a 'Hardware Needed' button at the top left, a close button (X) at the top right, a menu button (three dots) and a volume icon below it, and a page number '17' in a circle at the bottom left. At the bottom center, there are navigation arrows and a pause button.



(1) **H77 - LEFT UPRIGHT - W4L11173**
1"x3 3/8"x58" (24x86x1474)



(4) **H76 - LADDER RUNG - W4L07620**
1"x3 3/8"x17 1/4" (24x86x437)

4 FT LADDER WITH ATTACHMENT BOARD

STEP 1

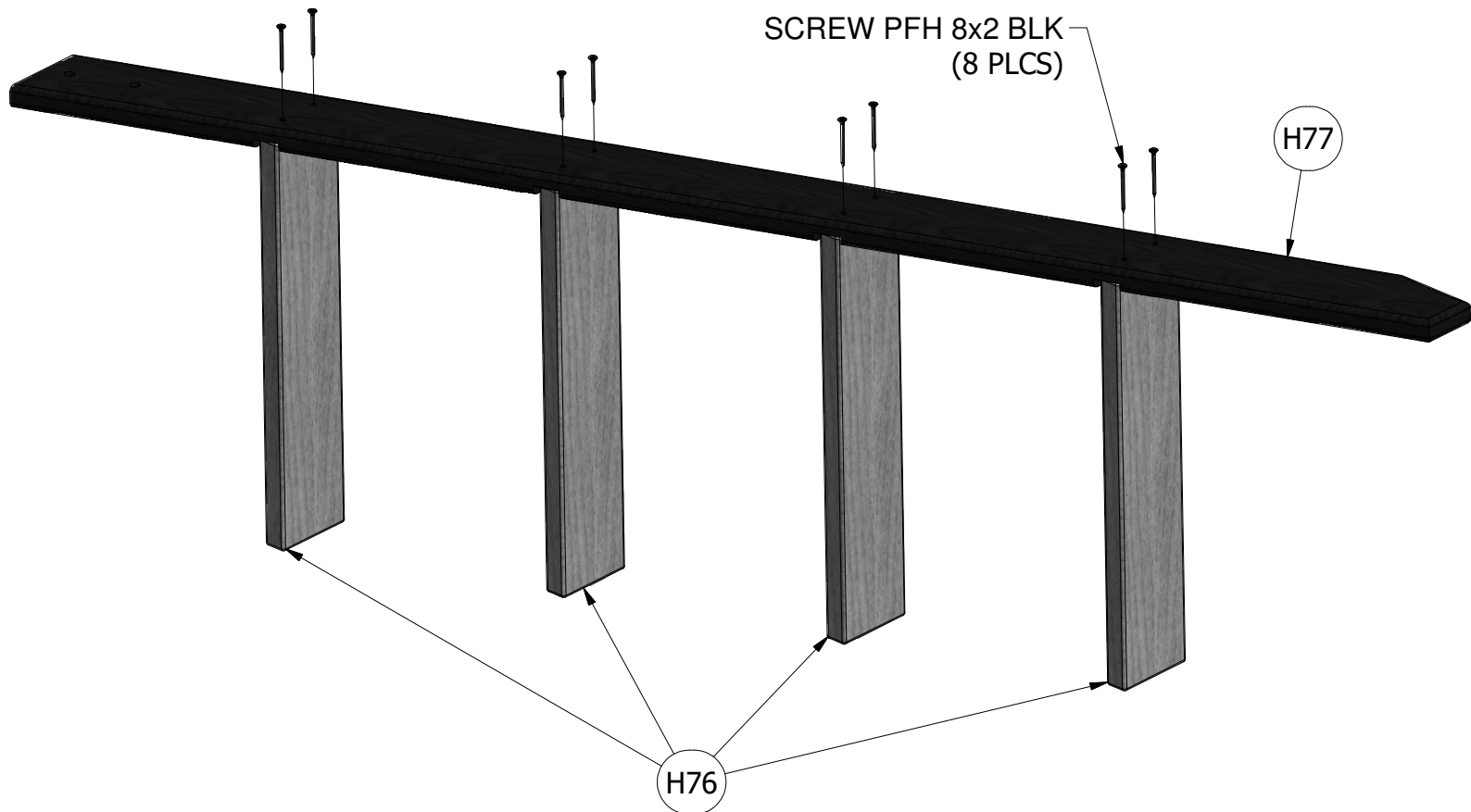
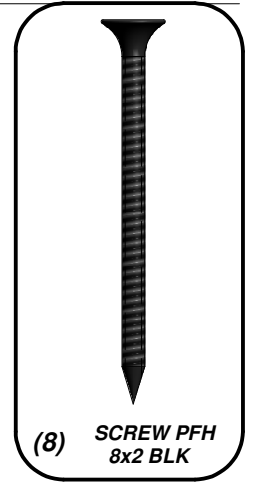



(1) H78 - RIGHT UPRIGHT - W4L11174
1"x3 3/8"x58" (24x86x1474)

STEP 2

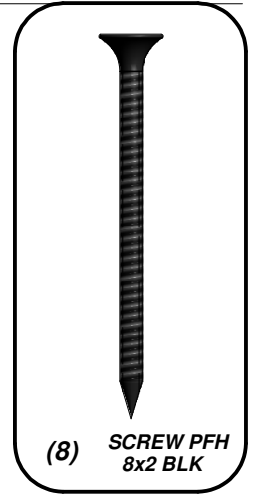

(8) SCREW PFH
8x2 BLK

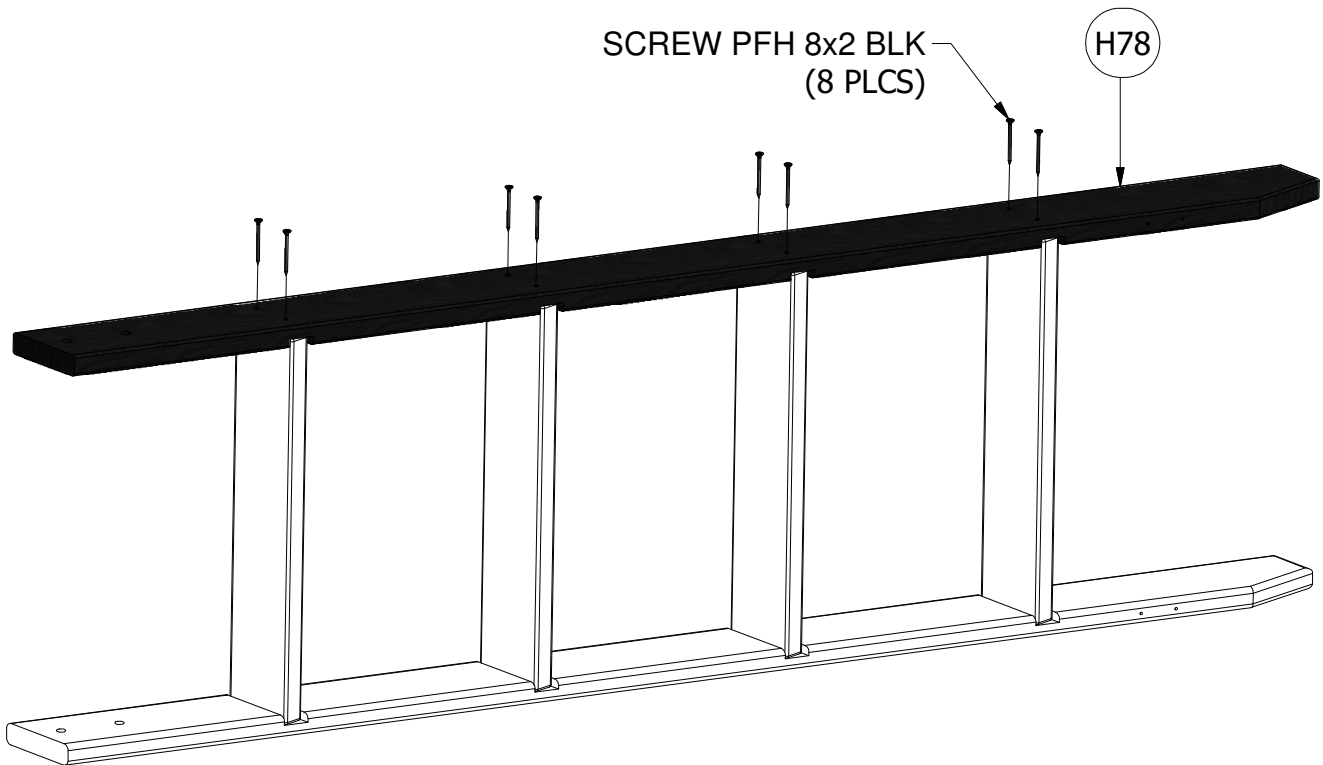



(1) **M110 - ATTACHMENT BOARD - W4L11172**
5/8"x3 3/8"x18 1/4" (16x86x465)



(1) **M73 - REAR SUPPORT - W4L07619**
5/8"x3 3/8"x18 1/4" (16x86x465)

STEP 3

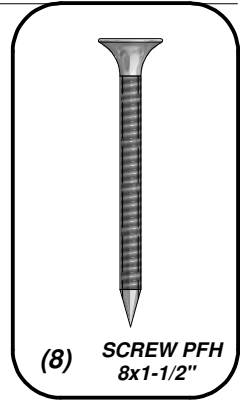

(8) **SCREW PFH**
8x1-1/2"

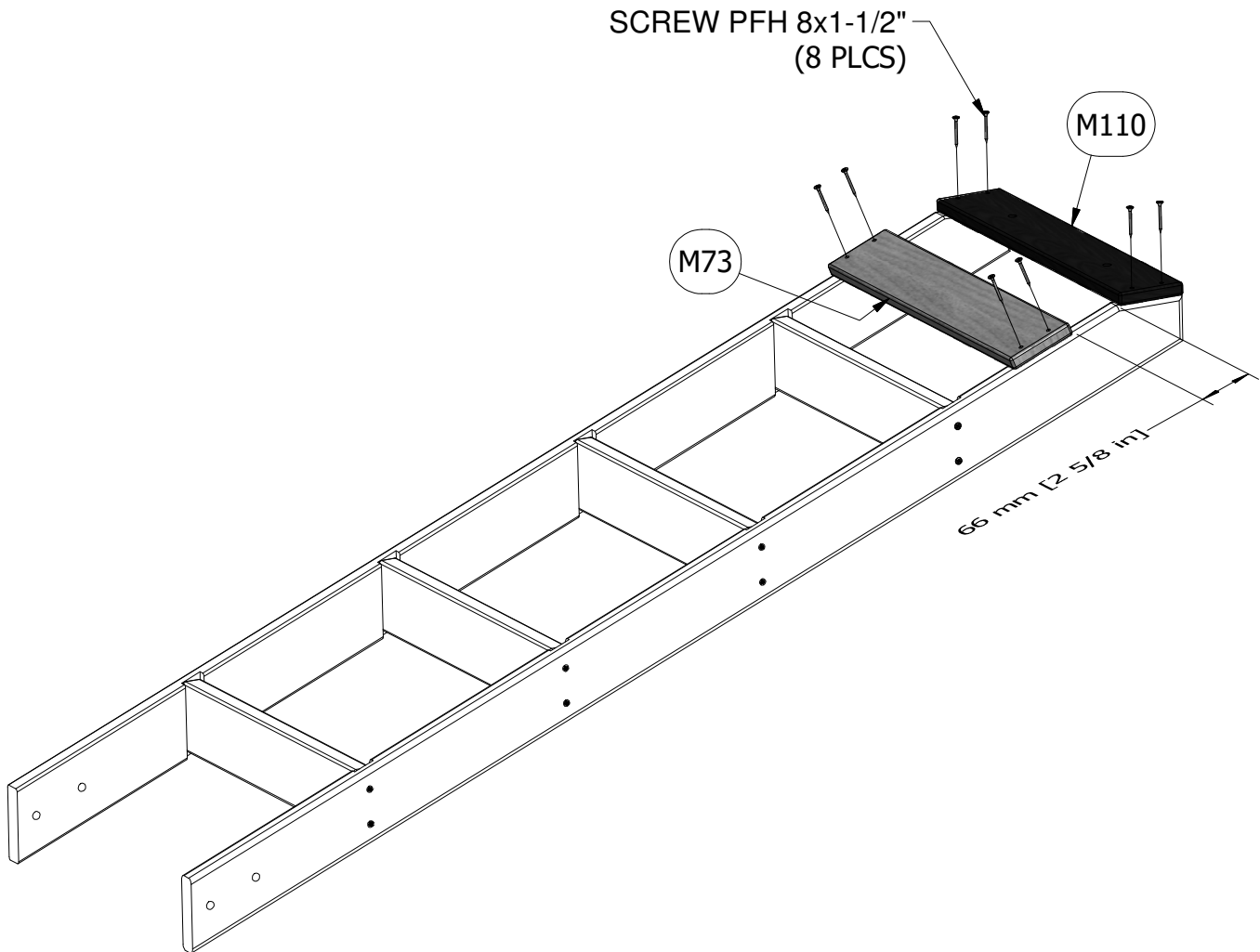

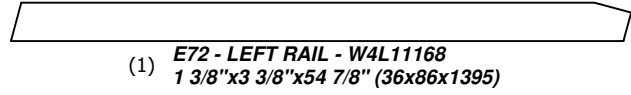

(1) E72 - LEFT RAIL - W4L11168
1 3/8"x3 3/8"x54 7/8" (36x86x1395)

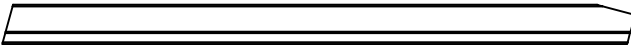

(1) E73 - RIGHT RAIL - W4L11169
1 3/8"x3 3/8"x54 7/8" (36x86x1395)

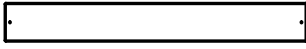

(1) M108 - TOP BOARD - W4L11170
5/8"x3 3/8"x26 1/4" (16x86x667)



(1) M77 - ROCK WALL BOARD - W4L11171
5/8"x3 3/8"x25" (16x86x635)

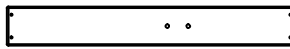

(4) M75 - ROCK WALL BOARD - W4L07627
5/8"x3 3/8"x25" (16x86x635)

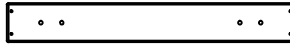

(4) M76 - ROCK WALL BOARD - W4L07626
5/8"x3 3/8"x25" (16x86x635)



(7) M74 - ROCK WALL BOARD - W4L07624
5/8"x3 3/8"x25" (16x86x635)

ROCKWALL STEP 1

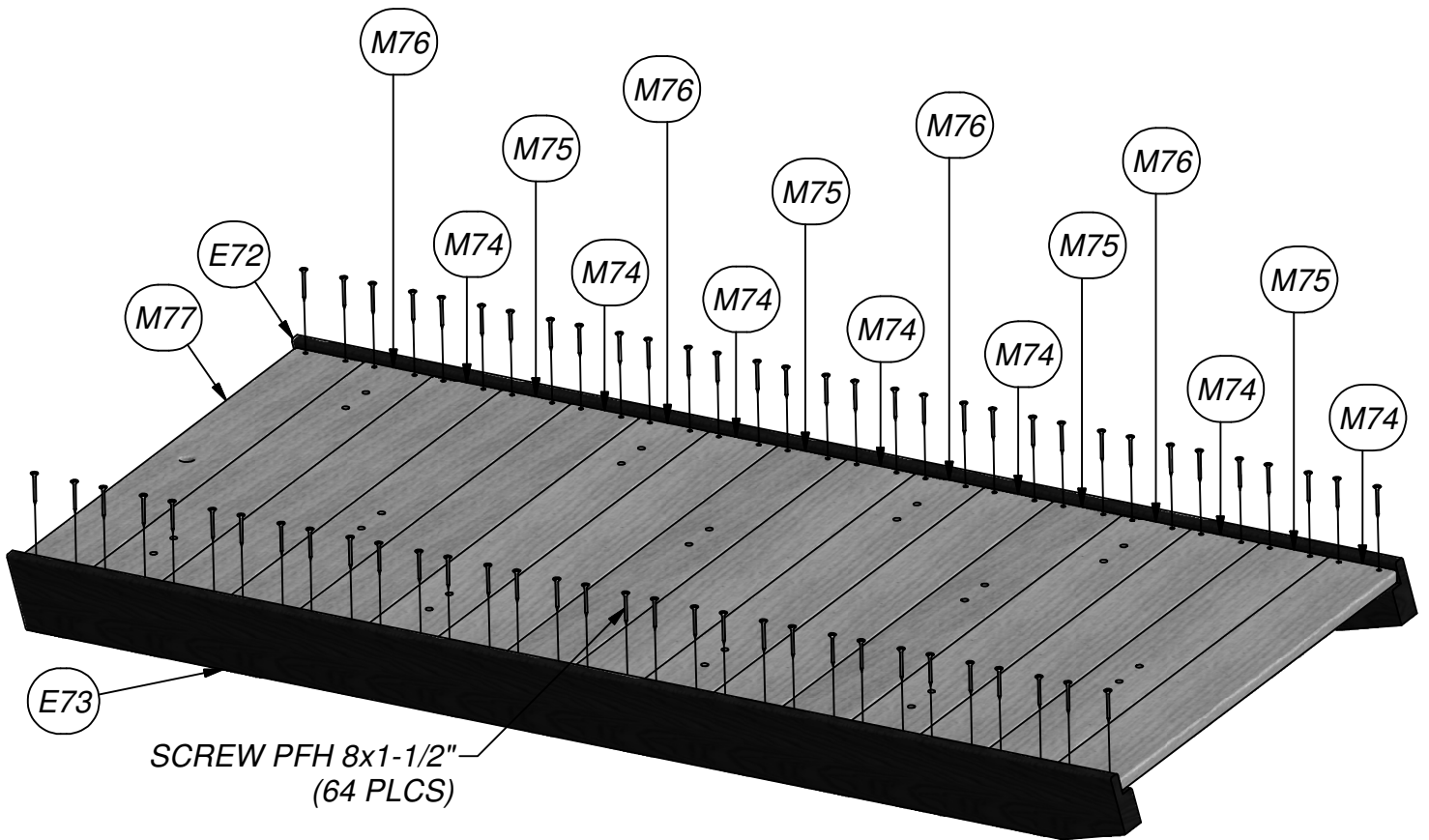
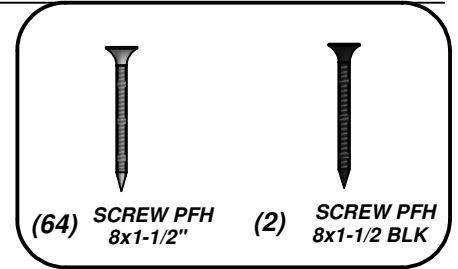

NOTE:
HOLE LOCATION IS
CLOSER TO BOTTOM

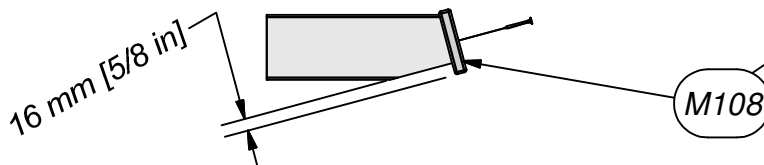
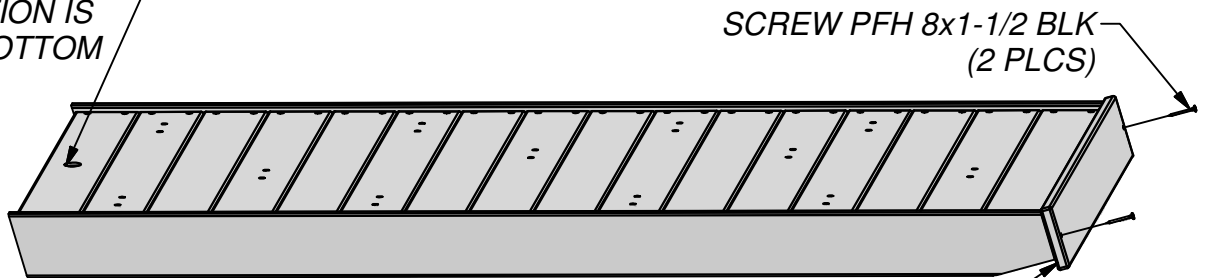

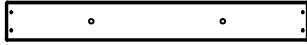

- (1) **M102 - ATTACHMENT BOARD - W4L11167**
5/8"x3 3/8"x26 1/4" (16x86x667)

**ROCKWALL
STEP 2**

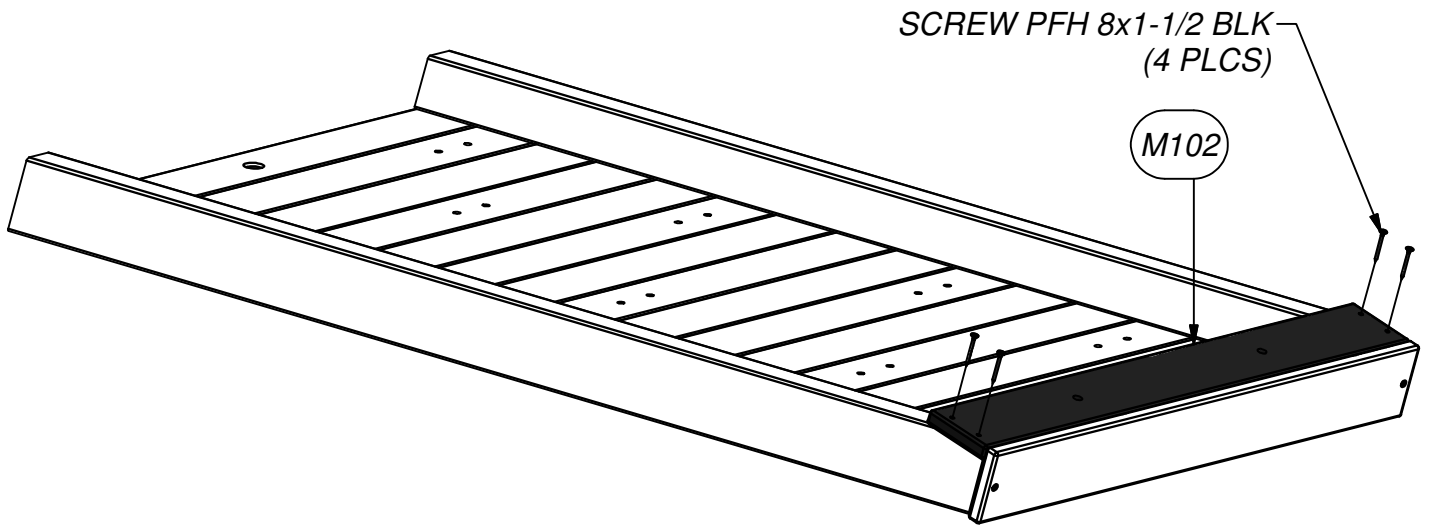
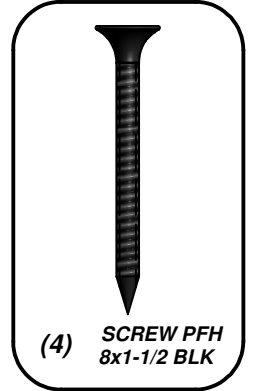



(3) - GREEN HC ROCK #1 - A6P00036



(3) - RED HC ROCK #1 - A6P00038



(3) - BLUE HC ROCK #2 - A6P00040

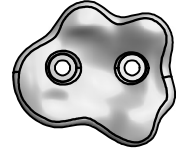

(3) - YELLOW HC ROCK #1 - A6P00042

ROCKWALL STEP 3

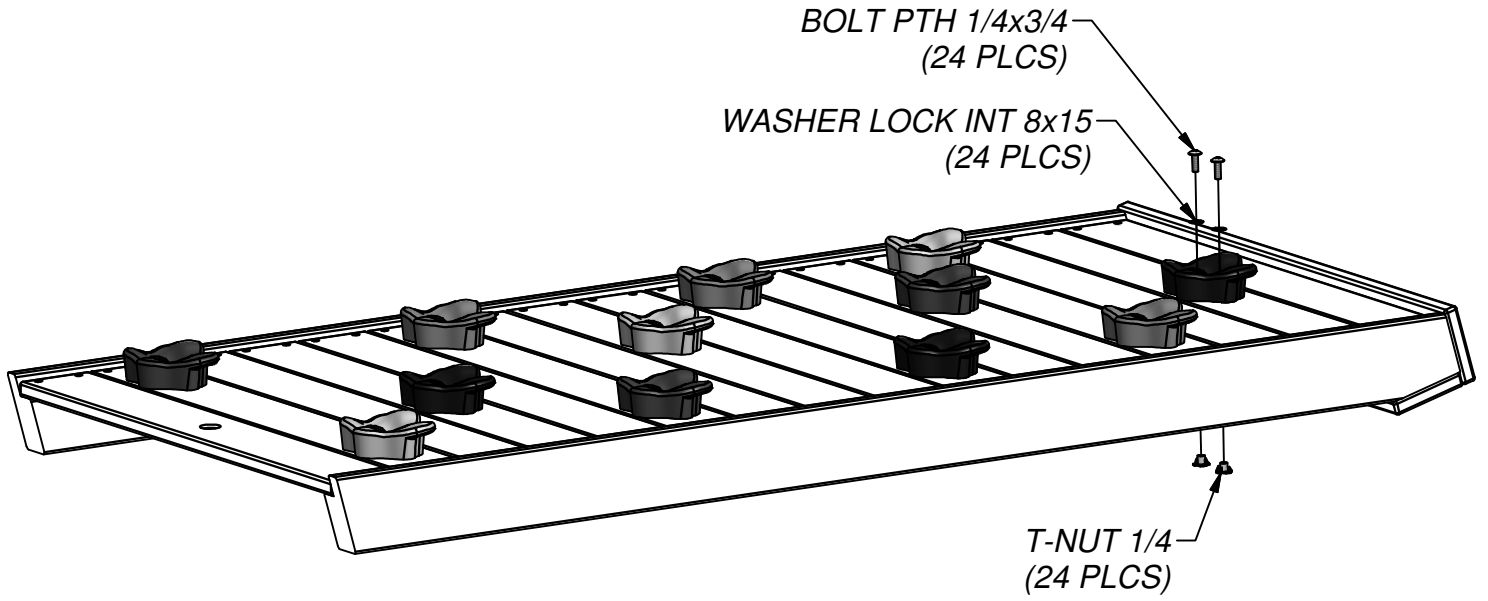
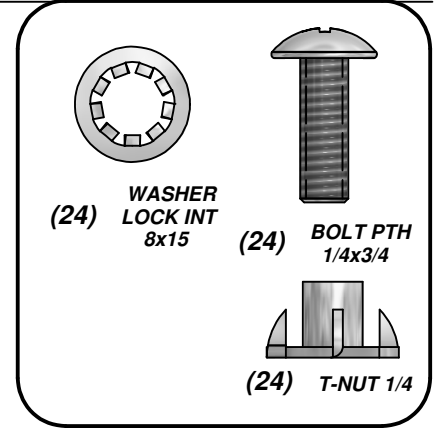

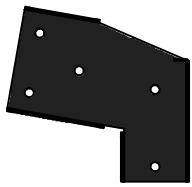

(1) **A74 - HEAVY DUTY SWING BEAM EXT.WEB SWING - W4L11647**
3 3/8"x5 1/4"x89 1/2" (86x134x2274)

(1) - **SWING BEAM EXTENSION BRACKET-RIGHT - A4M00618**

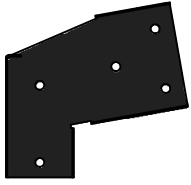

(1) - **SWING BEAM EXTENSION BRACKET-LEFT - A4M00617**



(2) - **L BRACKET 66x66x127 - BLK - A4M00619**

SWING BEAM ASSEMBLY STEP 1

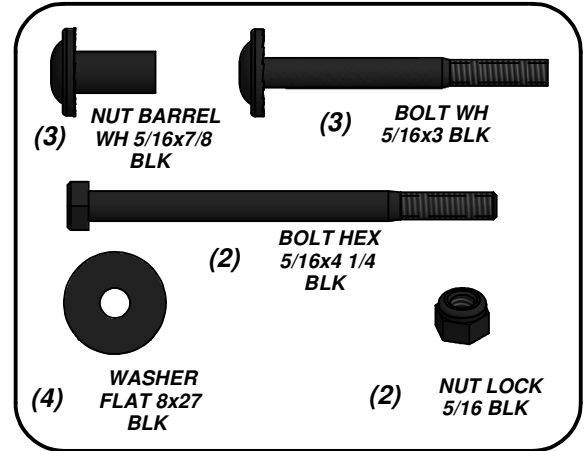
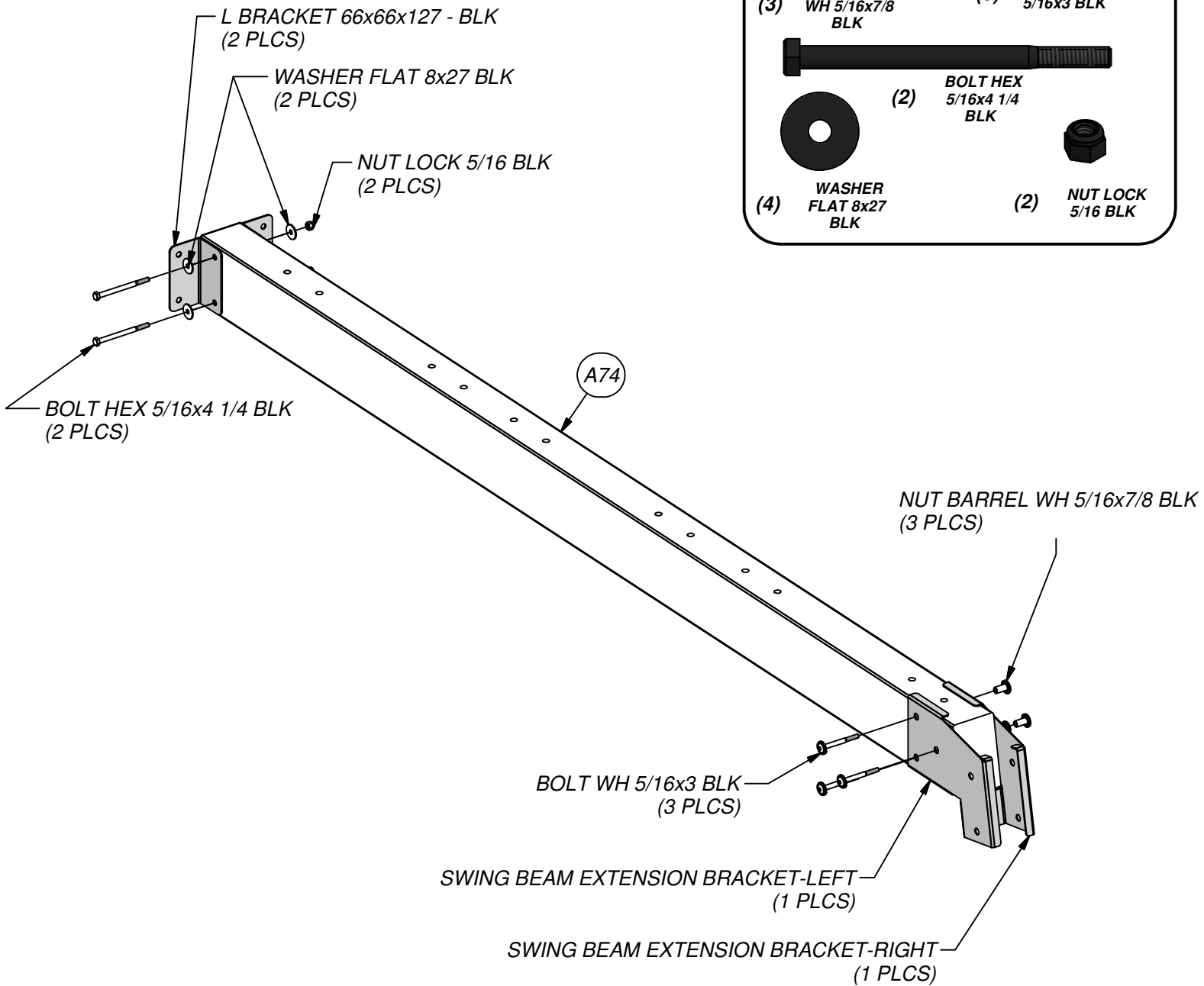

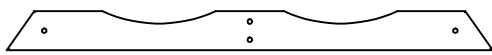

(1) **E79 - END SUPPORT - W4L11650**
1 1/2"x3 1/2"x42" (36x86x1072)

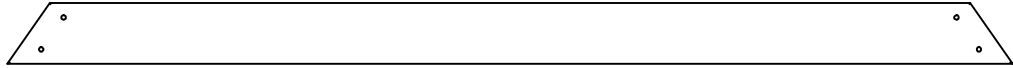

(1) **G80 - GROUND BOARD - W4L11649**
1"x5 1/4"x87 3/8" (24x134x2218)

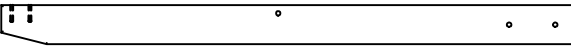

(1) **SP1 - SWING BEAM SUPPORT - W4L11651**
3 3/8"x3 3/8"x49 5/8" (86x86x1260)

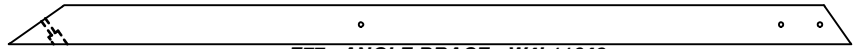

(2) **E77 - ANGLE BRACE - W4L11648**
1 3/8"x3 3/8"x73 1/8" (36x86x1859)

SWING BEAM ASSEMBLY STEP 2

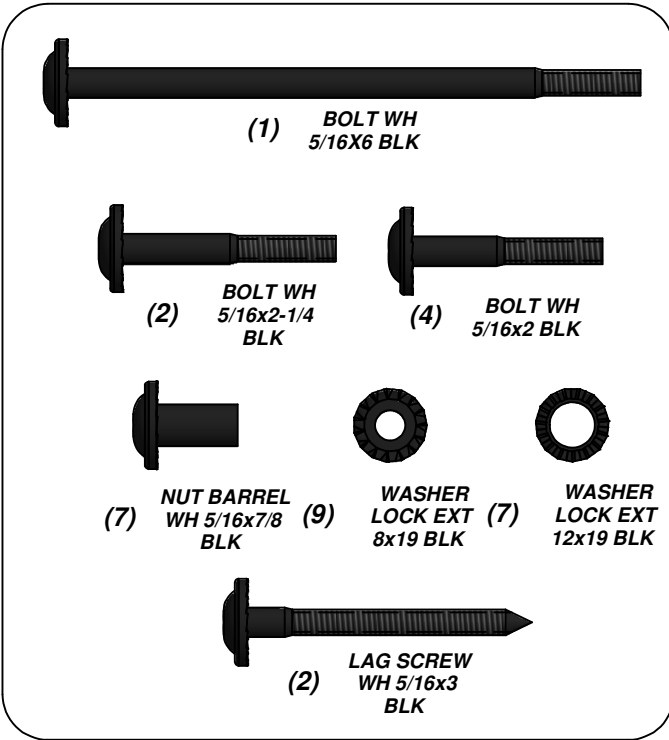
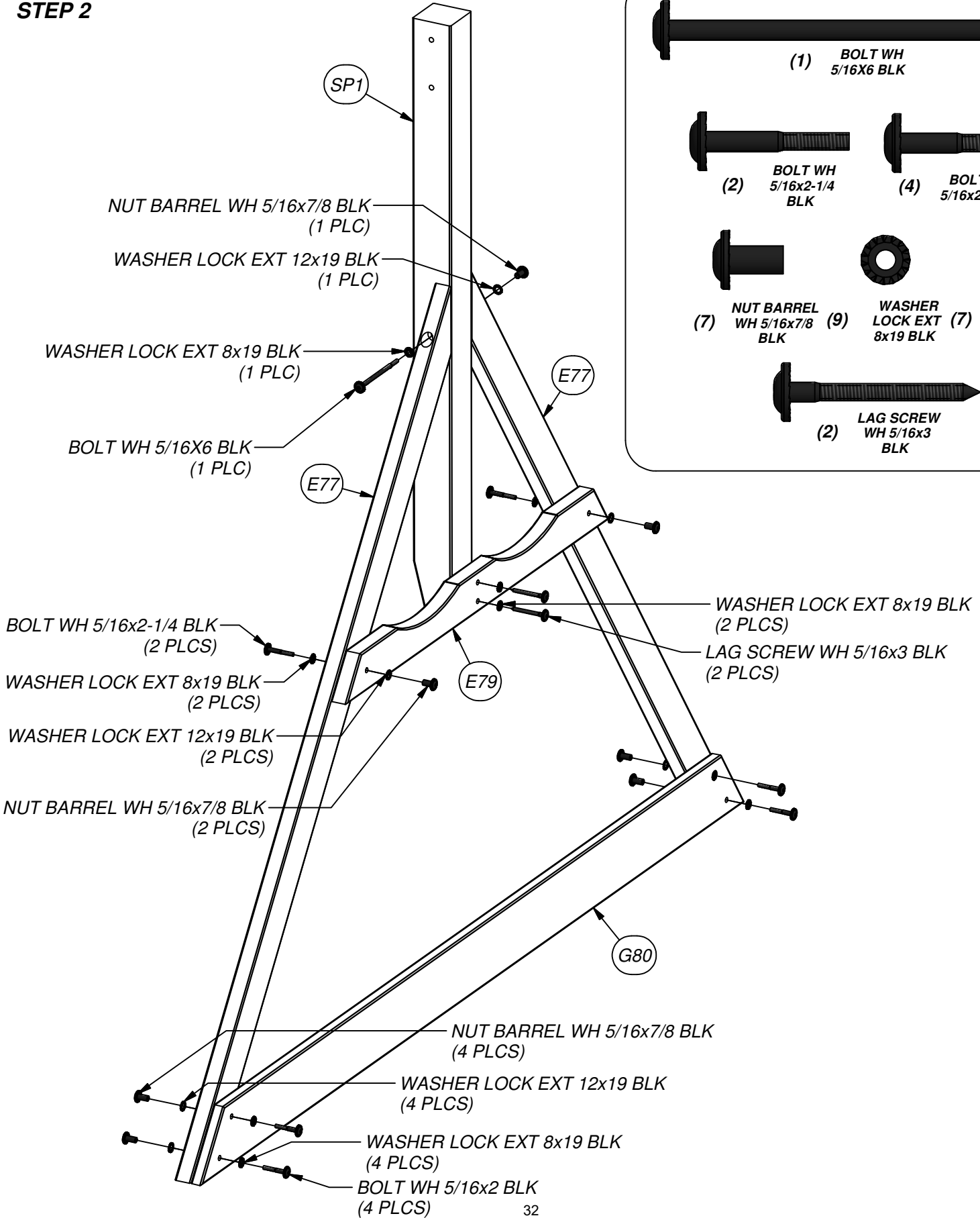

**SWING BEAM ASSEMBLY
STEP 3**

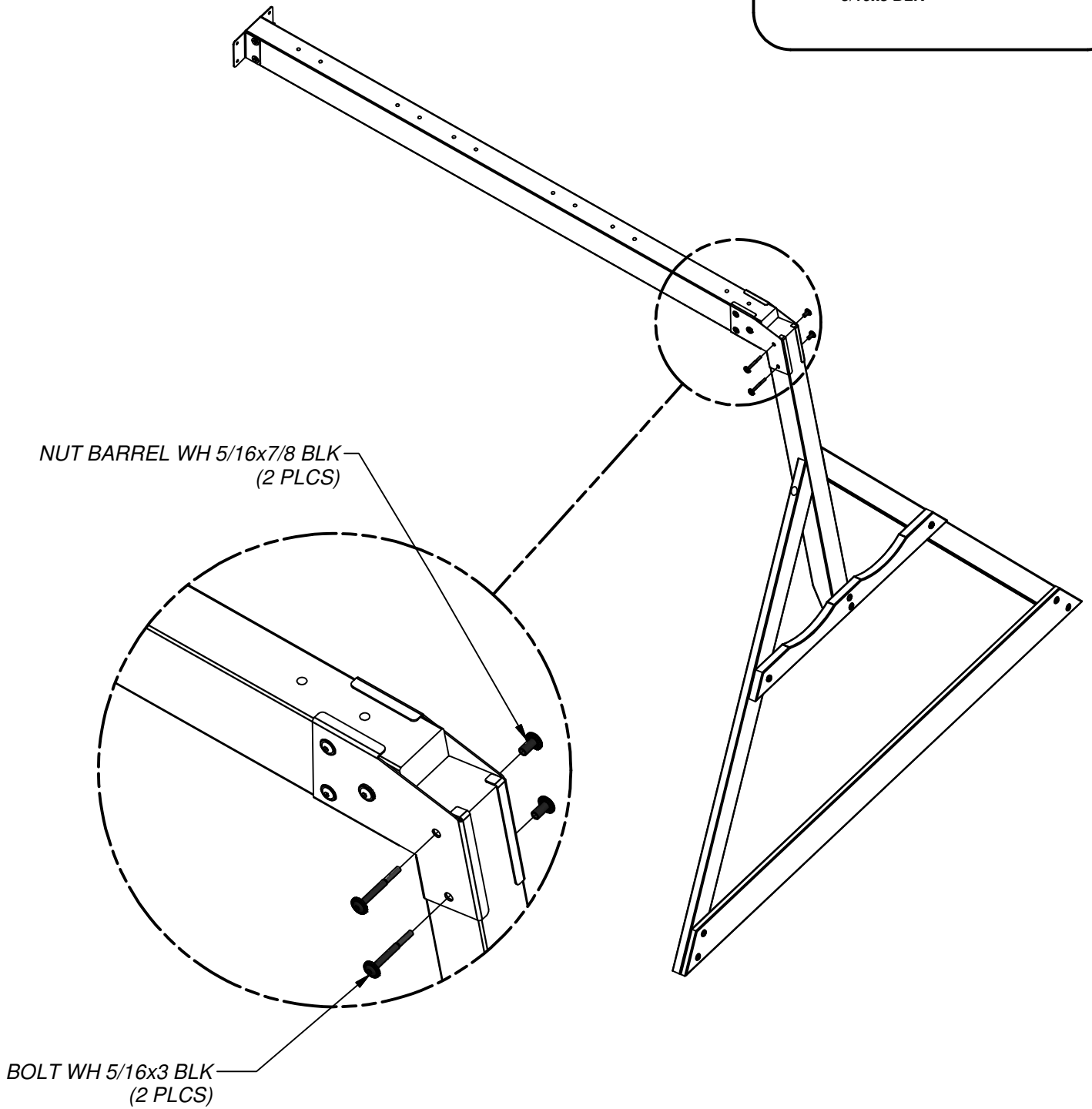
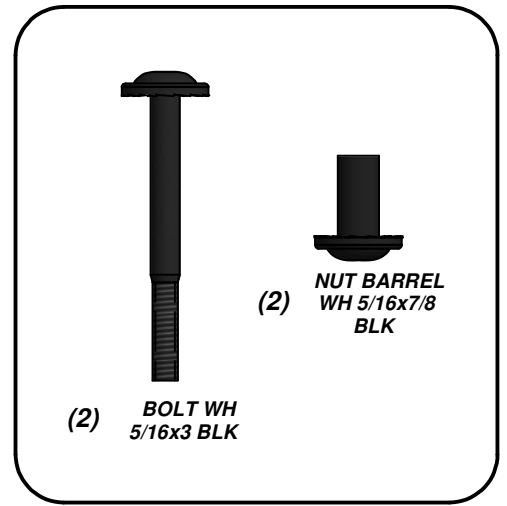

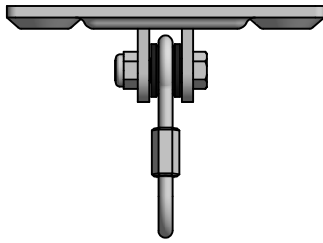

(6) *BY - SWING HANGER QUICK LINK - A4M00505-3*

**SWING BEAM ASSEMBLY
STEP 4**

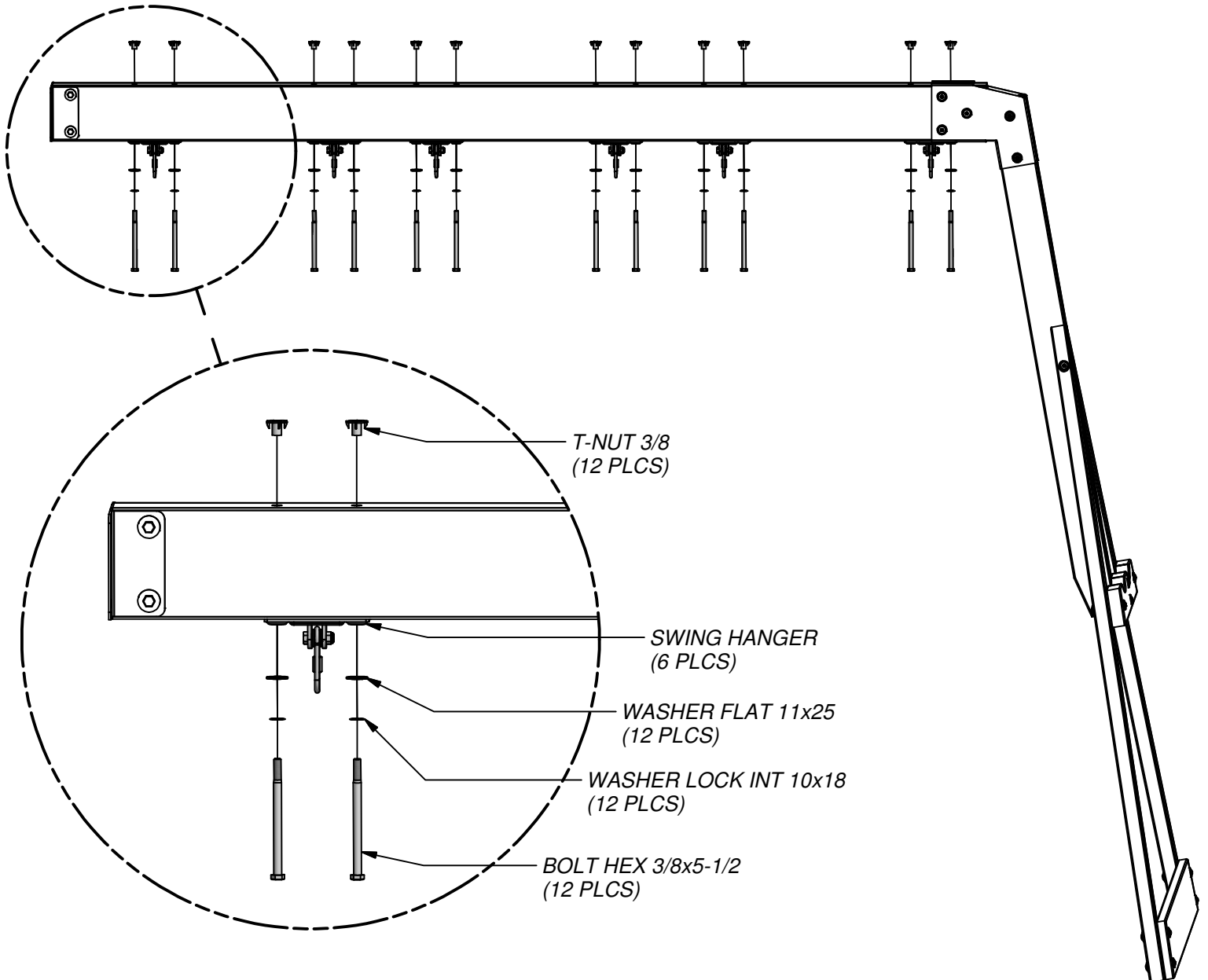
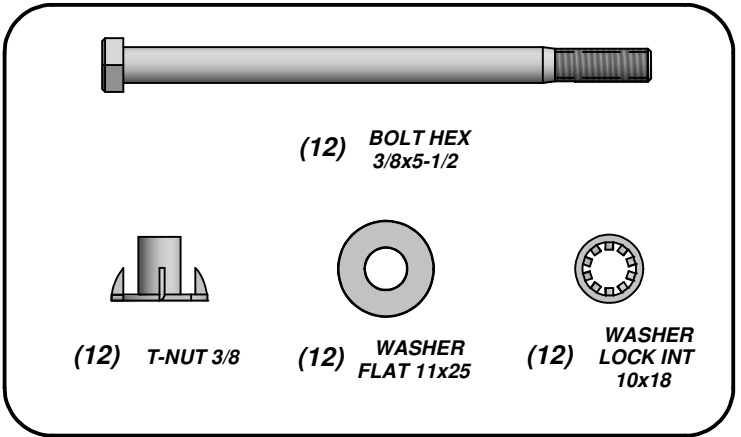



(1) E7 - RIGHT REAR UPRIGHT - W4L11134
1 3/8"x3 3/8"x43 1/2" (36x86x1104)

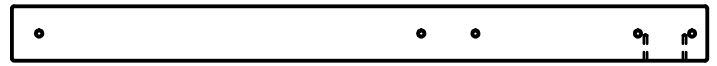

(1) E9 - RIGHT FRONT UPRIGHT - W4L11136
1 3/8"x3 3/8"x43 1/2" (36x86x1104)



(1) K12 - ARCHED WALL RAIL - W4L11143
5/8"x5 1/4"x40 5/8" (16x134x1032)



(1) G1 - SWING BEAM MOUNT - W4L11137
1"x5 1/4"x62 1/8" (24x134x1577)

STEP 1



NOTE: PAY CLOSE ATTN TO ALL BOARD FEATURES & HOLES FOR CORRECT PLACEMENT & ORIENTATION ON ALL STEPS.

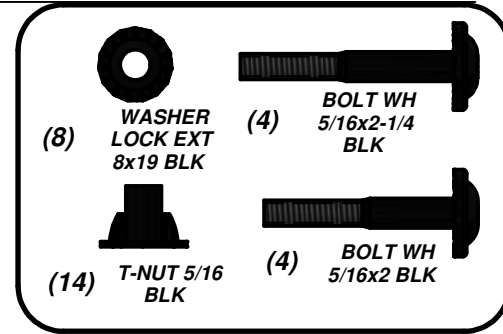

BOLT WH 5/16x2-1/4 BLK
(4 PLCS)

WASHER LOCK EXT 8x19 BLK
(4 PLCS)

NOTE HOLE LOCATIONS

T-NUT 5/16 BLK
(14 PLCS)



(8) WASHER LOCK EXT 8x19 BLK



(4) BOLT WH 5/16x2-1/4 BLK



(14) T-NUT 5/16 BLK



(4) BOLT WH 5/16x2 BLK

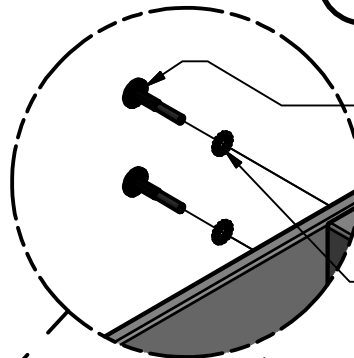
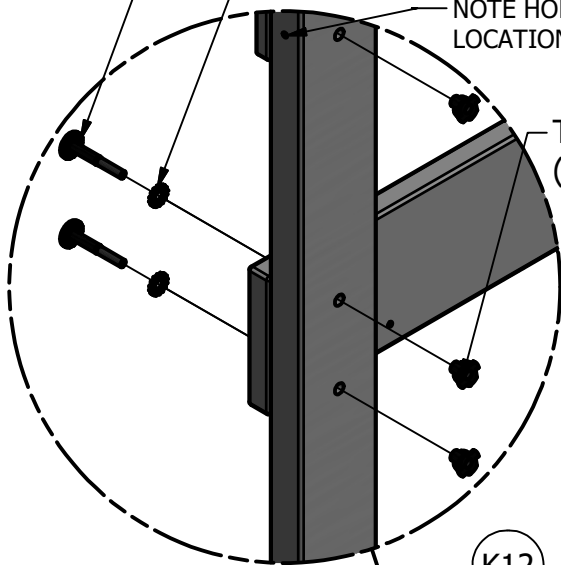

BOLT WH 5/16x2 BLK
(4 PLCS)

WASHER LOCK EXT 8x19 BLK
(4 PLCS)

NOTE HOLE LOCATIONS

K12

G1

NOTE HOLE LOCATIONS

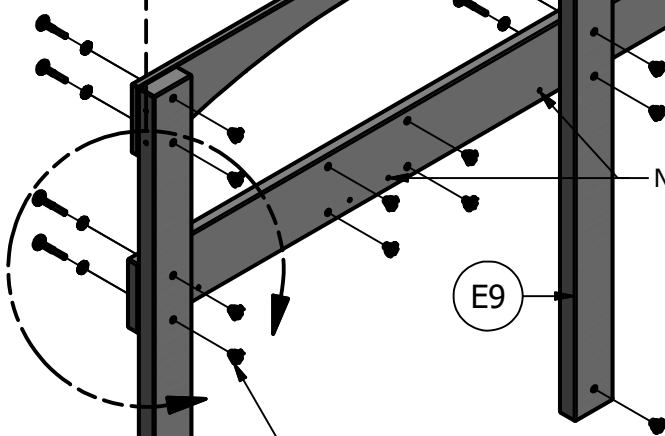

E9

E7

T-NUT 5/16 BLK
(14 PLCS)



NOTE HOLE LOCATIONS

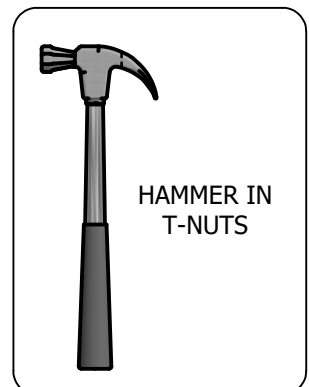

HAMMER IN T-NUTS

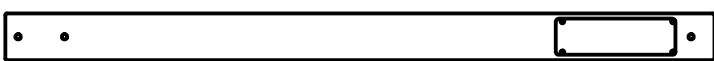

(1) E1 - RIGHT REAR UPRIGHT - W2A02496
1 3/8"x3 3/8"x51 3/4" (36x86x1314)

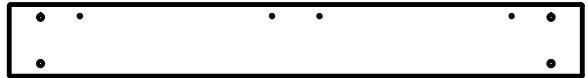

(1) K1 - GROUND BOARD - W4L11113
5/8"x5 1/4"x41 7/8" (16x134x1064)

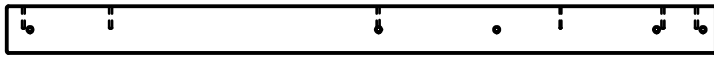

(1) E4 - RIGHT FRONT UPRIGHT - W4L11119
1 3/8"x3 3/8"x51 3/4" (36x86x1314)



(1) K5 - RIGHT CENTER WALL RAIL - W4L11120
5/8"x5 1/4"x62 3/4" (16x134x1593)



(1) - "A" REVISION TAG - A100314

STEP 2

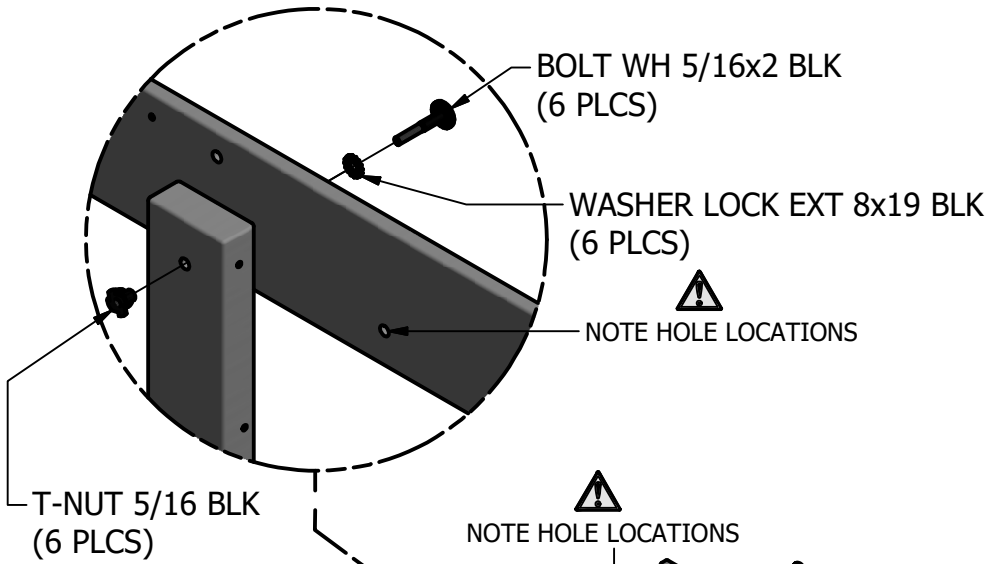
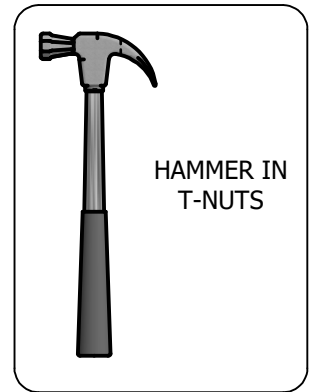
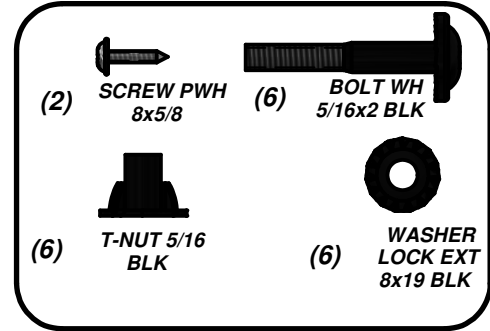

T-NUT 5/16 BLK
(6 PLCS)

NOTE HOLE LOCATIONS

SCREW PWH 8x5/8
(2 PLCS)

"A" REVISION TAG

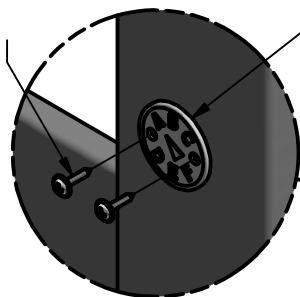

NOTE HOLE LOCATIONS

NOTE HOLE LOCATIONS

NOTE HOLE LOCATIONS

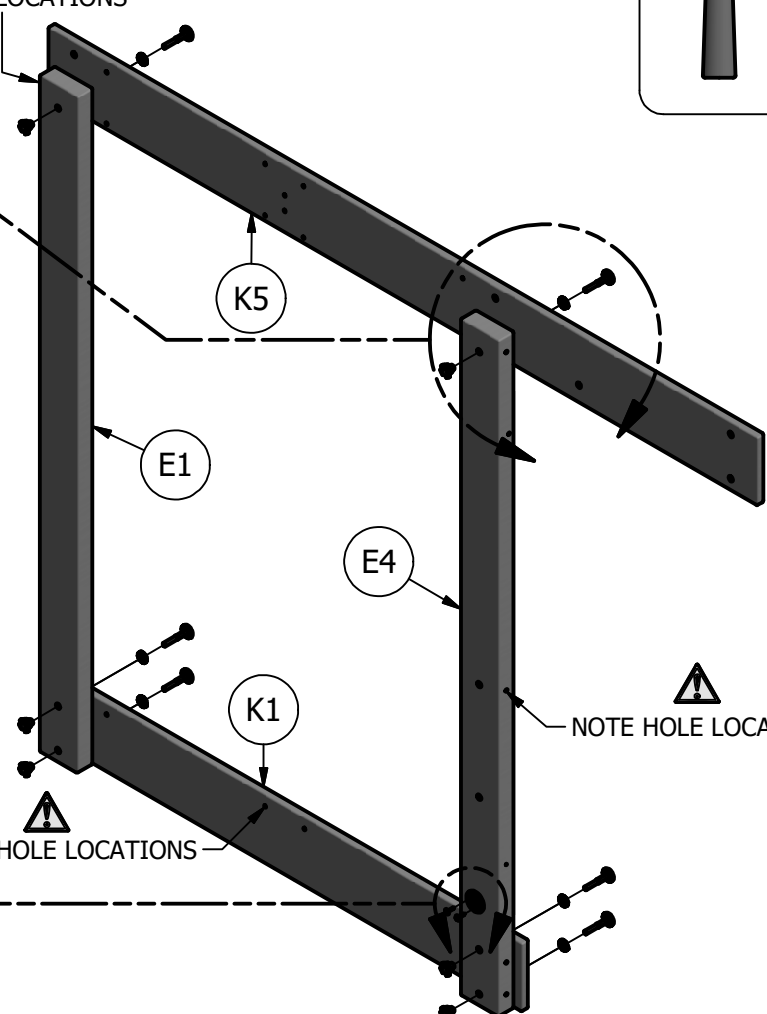

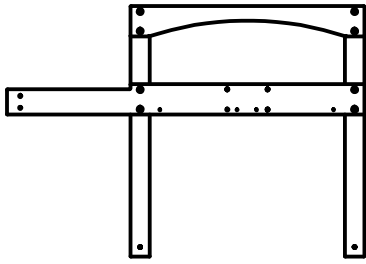

PRE-ASSEMBLED PARTS
FROM STEPS 1 & 2

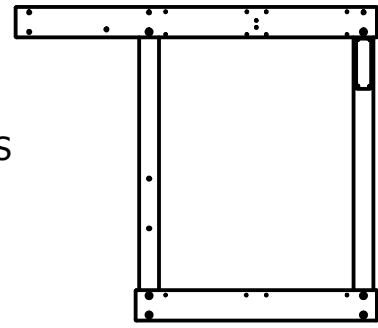

STEP 3

•ASSEMBLE THE TOP AND BOTTOM OF THE RIGHT UPRIGHT.

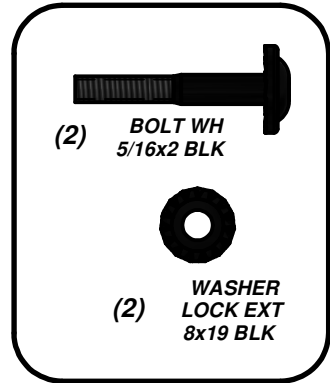

 NOTE BOARD
ORIENTATION

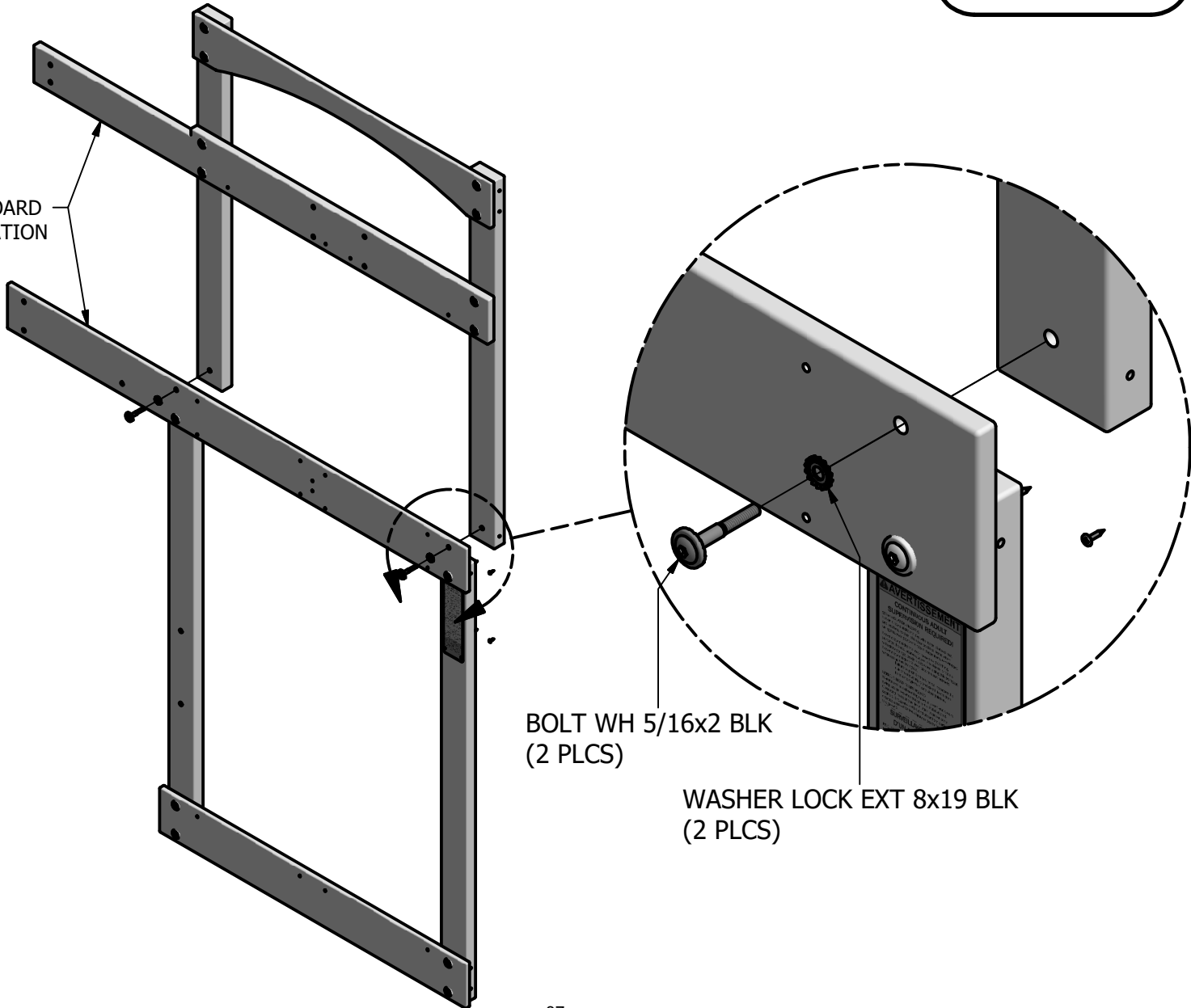

BOLT WH 5/16x2 BLK
(2 PLCS)

WASHER LOCK EXT 8x19 BLK
(2 PLCS)

- (1) **E2 - LEFT REAR UPRIGHT - W4L11117**
1 3/8"x3 3/8"x51 3/4" (36x86x1314)
- (1) **E3 - LEFT FRONT UPRIGHT - W4L11118**
1 3/8"x3 3/8"x51 3/4" (36x86x1314)
- (1) **E6 - LEFT REAR UPRIGHT - W4L11133**
1 3/8"x3 3/8"x43 1/2" (36x86x1104)
- (1) **E8 - LEFT FRONT UPRIGHT - W4L11135**
1 3/8"x3 3/8"x43 1/2" (36x86x1104)

- (1) **K2 - GROUND BOARD - W4L11114**
5/8"x5 1/4"x41 7/8" (16x134x1064)
- (1) **K8 - LEFT CENTER WALL RAIL - W4L11123**
5/8"x5 1/4"x40 5/8" (16x134x1032)
- (1) **K13 - ARCHED WALL RAIL - W4L11144**
5/8"x5 1/4"x40 5/8" (16x134x1032)

STEP 4

ASSEMBLE LEFT UPRIGHT

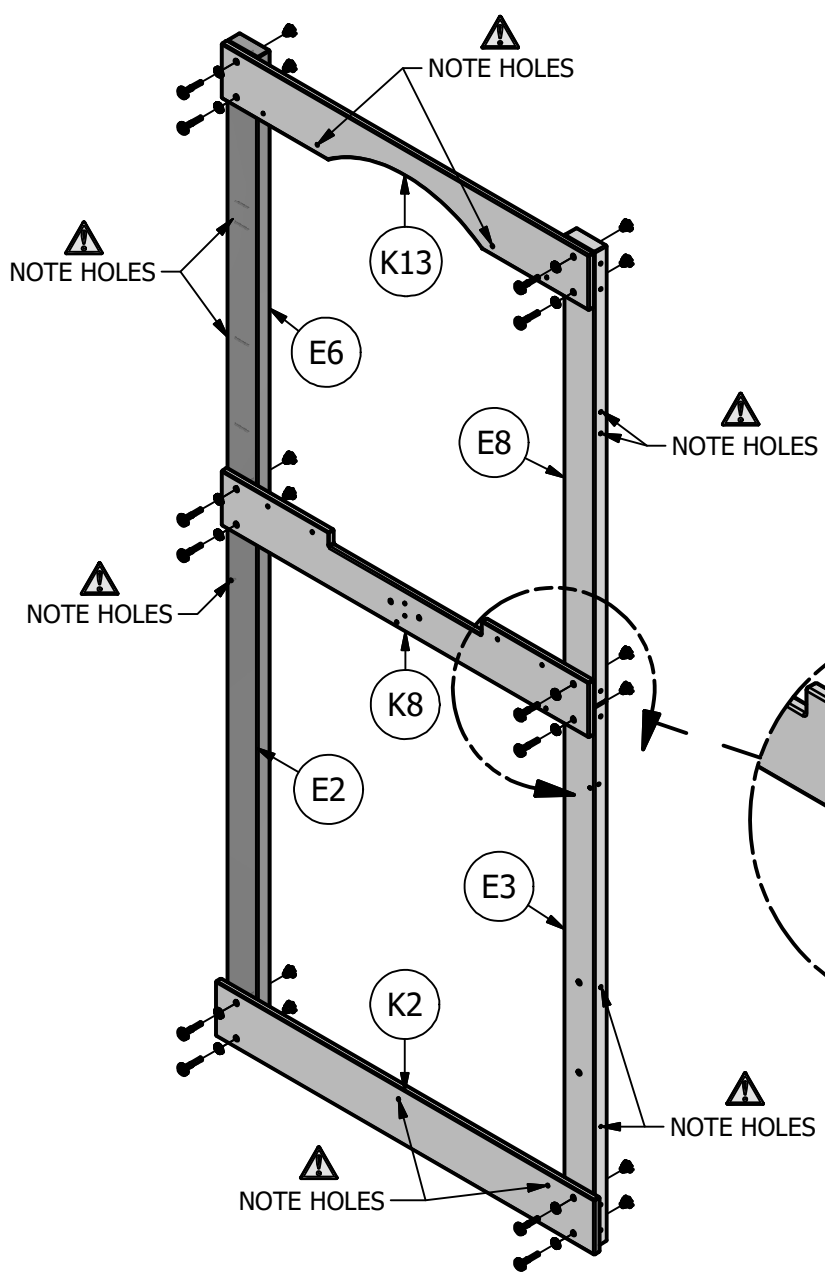



(12) **BOLT WH 5/16x2 BLK**



(12) **T-NUT 5/16 BLK**



(12) **WASHER LOCK EXT 8x19 BLK**

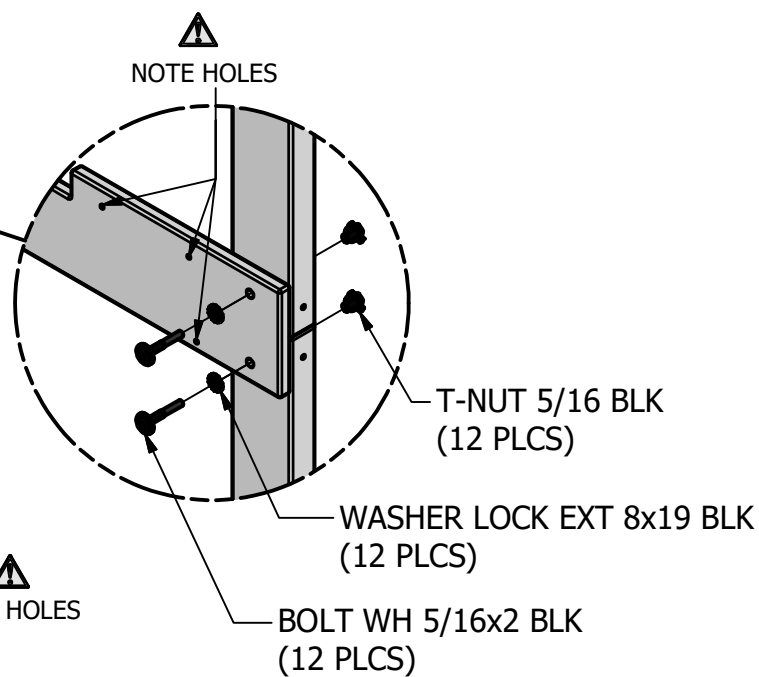



(1) **K15 - ANGLED WALL RAIL - W4L11146**
5/8"x5 1/4"x45 3/4" (16x134x1162)

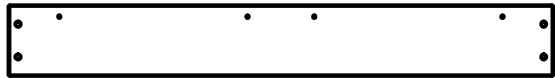

(1) **K4 - GROUND BOARD - W4L11116**
5/8"x5 1/4"x40 1/2" (16x134x1030)



(1) **K6 - FRONT CENTER WALL RAIL - W4L11121**
5/8"x5 1/4"x61 3/8" (16x134x1560)

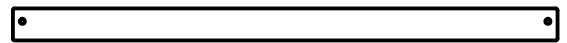

(1) **J1 - PORCH GROUND BOARD - W4L11128**
1"x2 3/8"x40 1/2" (24x60x1030)

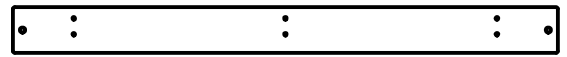

(1) **M1 - WALL RAIL - W4L11154**
5/8"x3 3/8"x40 1/2" (16x86x1030)

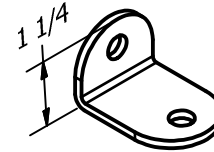

(1) **- L BRACKET BLACK 32x51 - A4M00710**

STEP 5

LAG SCREW WH 5/16x1-1/2 BLK (4 PLCS)

WASHER LOCK EXT 8x19 BLK (4 PLCS)

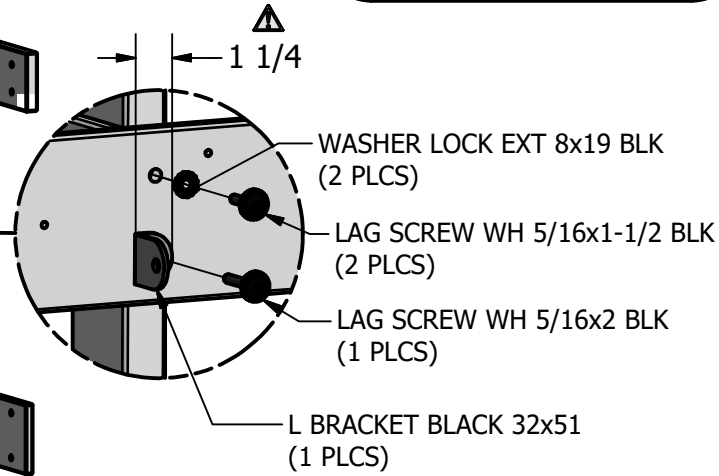
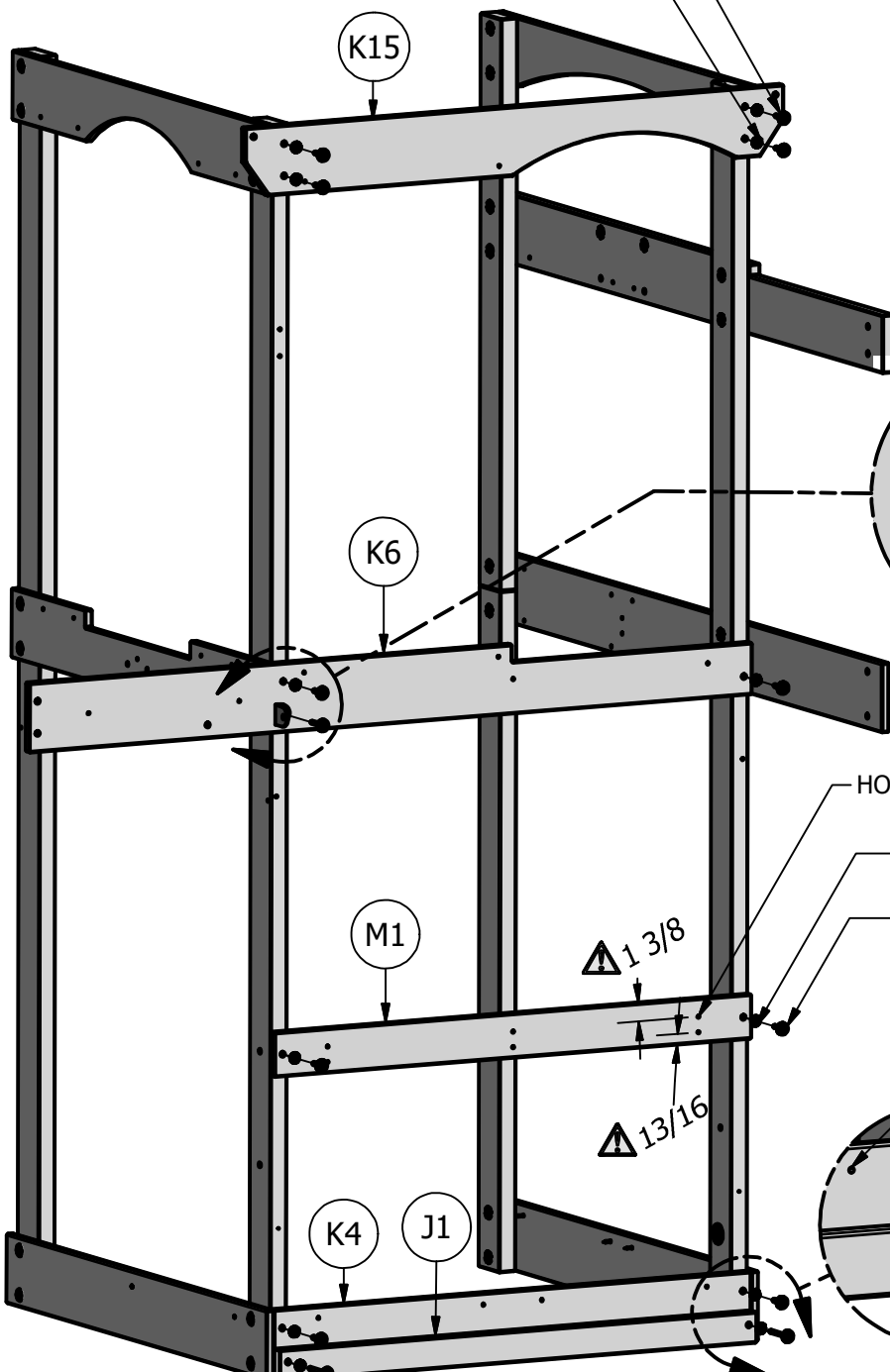
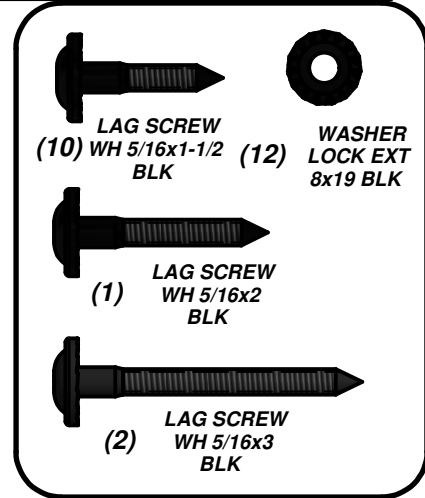

HOLES LOCATED TOWARD BOTTOM OF BOARD

WASHER LOCK EXT 8x19 BLK (2 PLCS)
LAG SCREW WH 5/16x1-1/2 BLK (2 PLCS)

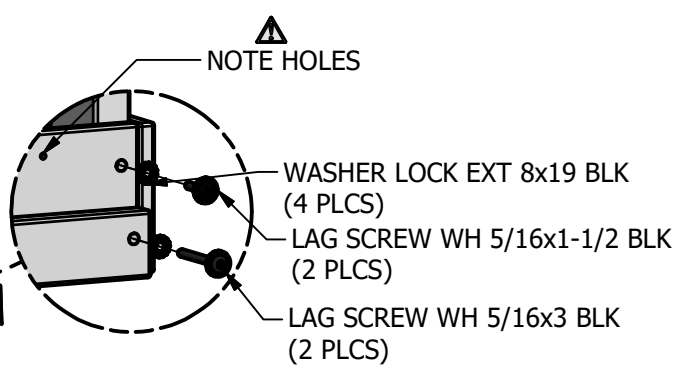

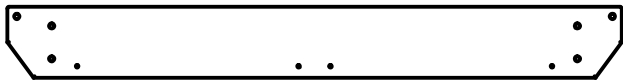

(1) **K14 - ANGLED WALL RAIL - W4L11145**
5/8"x5 1/4"x45 3/4" (16x134x1162)

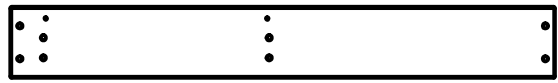

(1) **K3 - GROUND BOARD - W4L11115**
5/8"x5 1/4"x40 1/2" (16x134x1030)

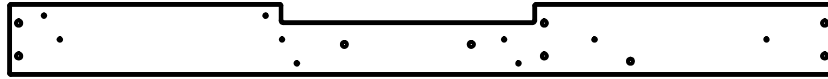

(1) **K7 - REAR CENTER WALL RAIL - W4L11122**
5/8"x5 1/4"x61 3/8" (16x134x1560)

STEP 6

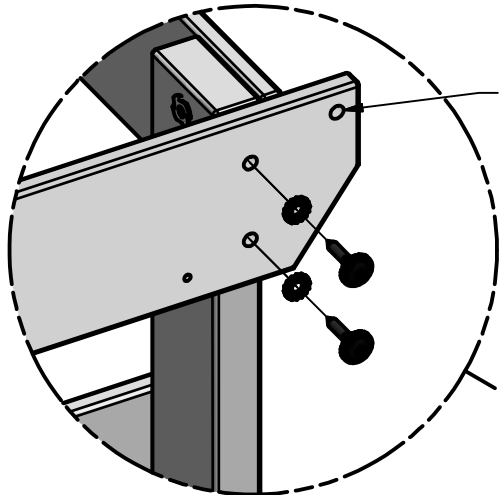

NOTE HOLES

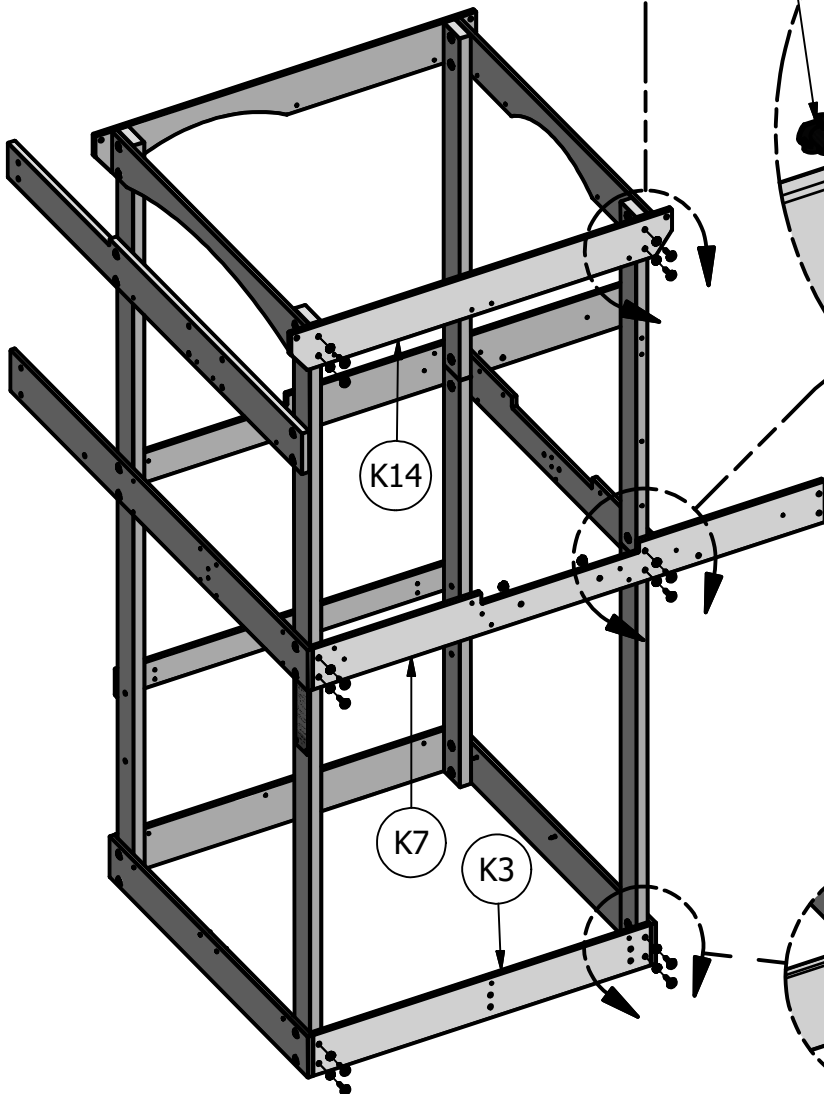
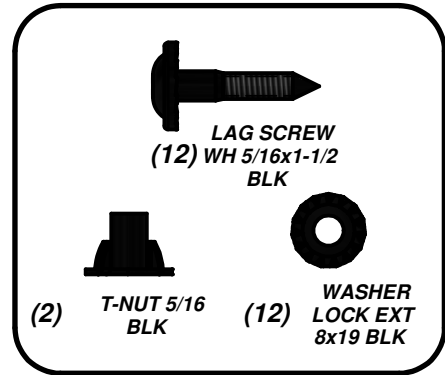

T-NUT 5/16 BLK
(2 PLCS)

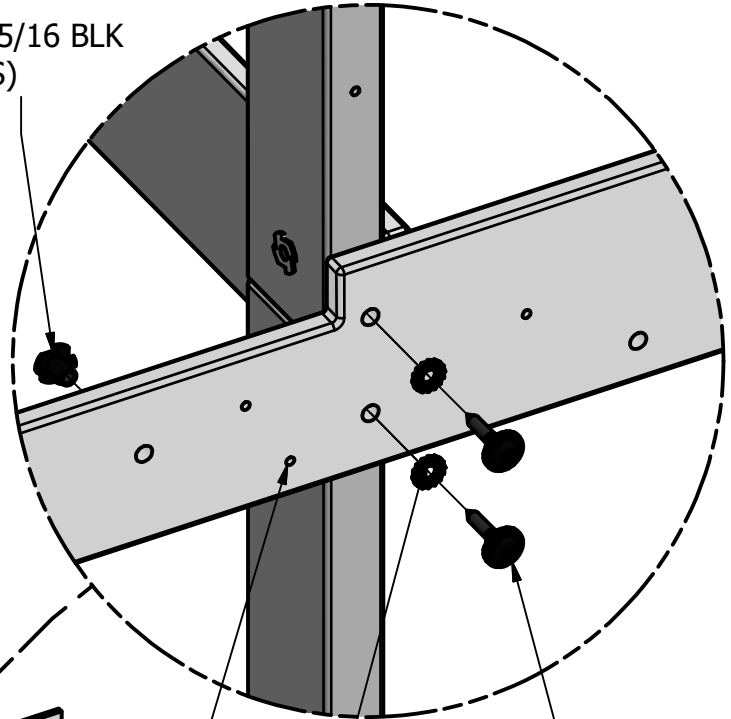

NOTE HOLES

WASHER LOCK EXT 8x19 BLK
(12 PLCS)

LAG SCREW WH 5/16x1-1/2 BLK
(12 PLCS)

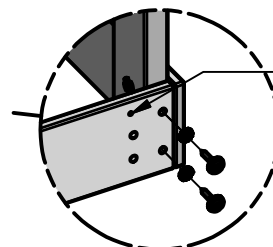

NOTE HOLES



(1) L2 - WALL RAIL - W4L11139
5/8"x4 3/8"x23 1/4" (16x112x590)

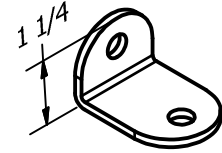

(1) - L BRACKET BLACK 32x51 - A4M00710

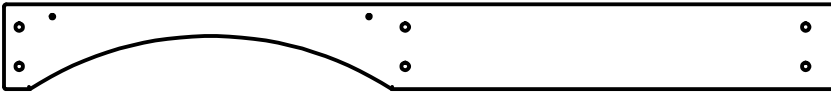

(1) L4 - ARCHED WALL RAIL - W4L11141
5/8"x4 3/8"x43 3/8" (16x112x1103)

STEP 7

L BRACKET BLACK 32x51
(1 PLC)

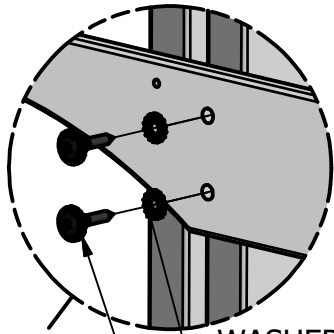
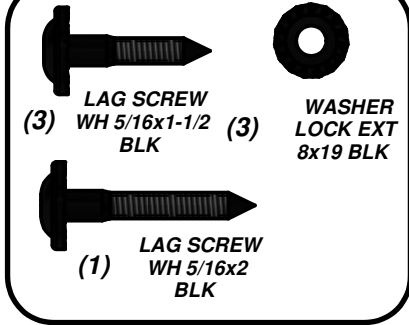

WASHER LOCK EXT 8x19 BLK
(3 PLCS)

LAG SCREW WH 5/16x1-1/2 BLK
(3 PLCS)

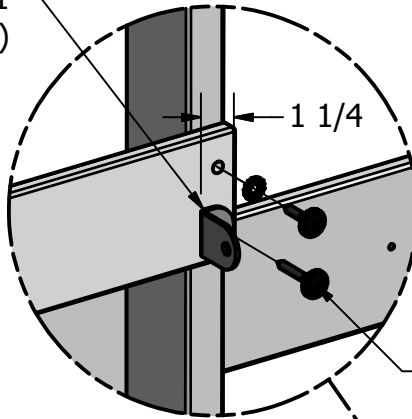

LAG SCREW WH 5/16x2 BLK
(1 PLC)

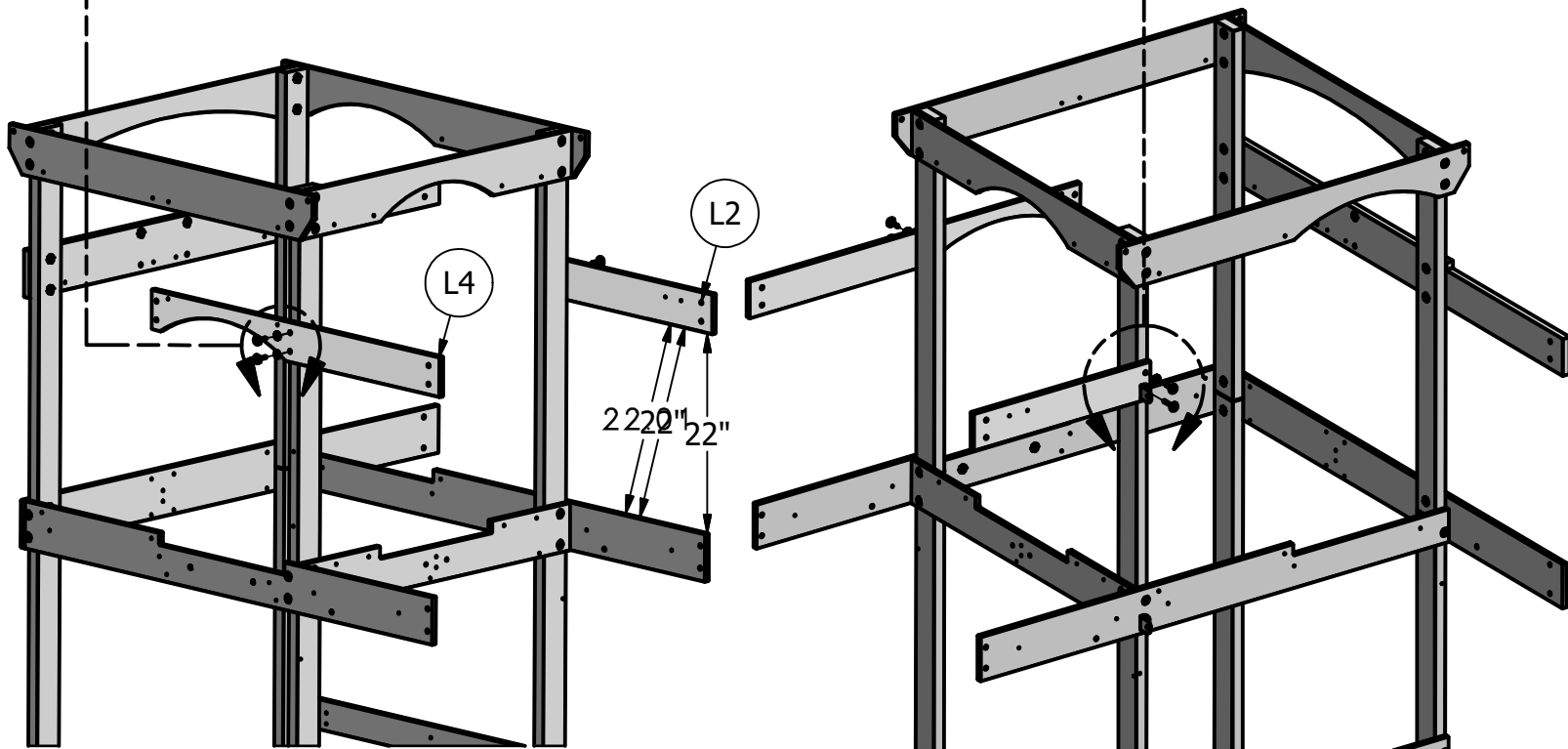

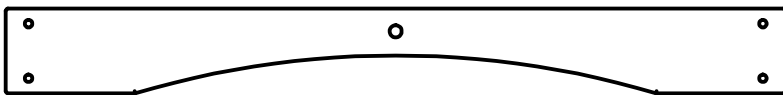

(1) **Q1 - ARCHED WALL RAIL - W4L11142**
1"x4 3/8"x40 5/8" (24x112x1032)



(1) **F1 - RIGHT BALCONY UPRIGHT - W4L11130**
1 3/8"x2 3/8"x31 3/4" (36x60x805)

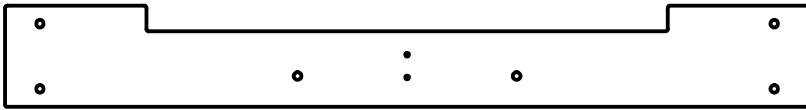

(1) **K11 - LEFT SIDE WALL BOARD - W4L11132**
5/8"x5 1/4"x41 7/8" (16x134x1064)



(1) **F2 - LEFT BALCONY UPRIGHT - W4L11131**
1 3/8"x2 3/8"x31 3/4" (36x60x805)

STEP 8

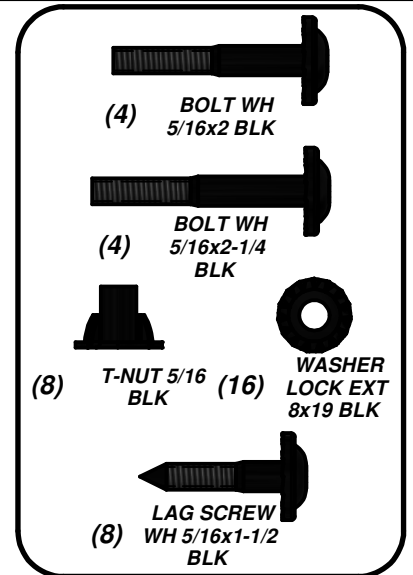
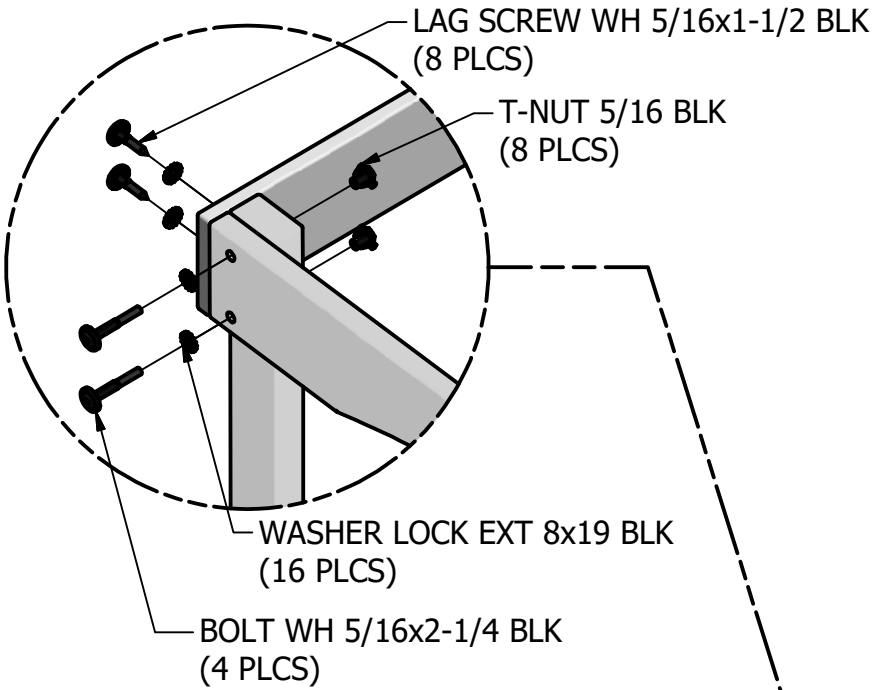

FRONT VIEW

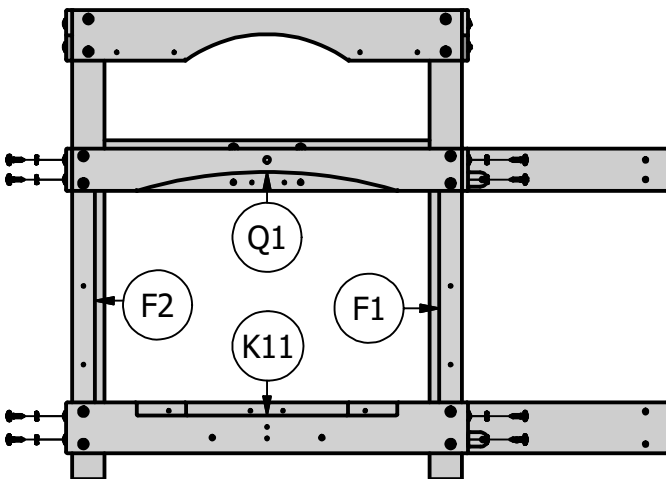

TOP VIEW

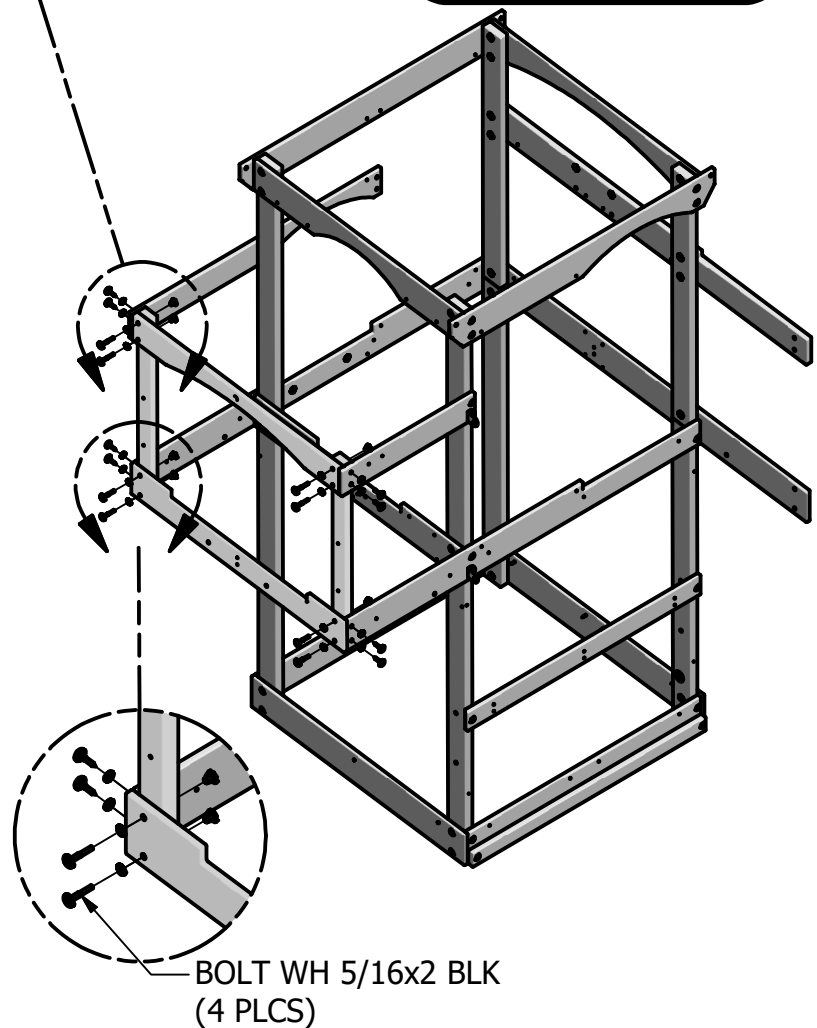



(2) **H4 - DECK BRACE - W4L11156**
1"x3 3/8"x12 3/4" (24x86x325)

STEP 9

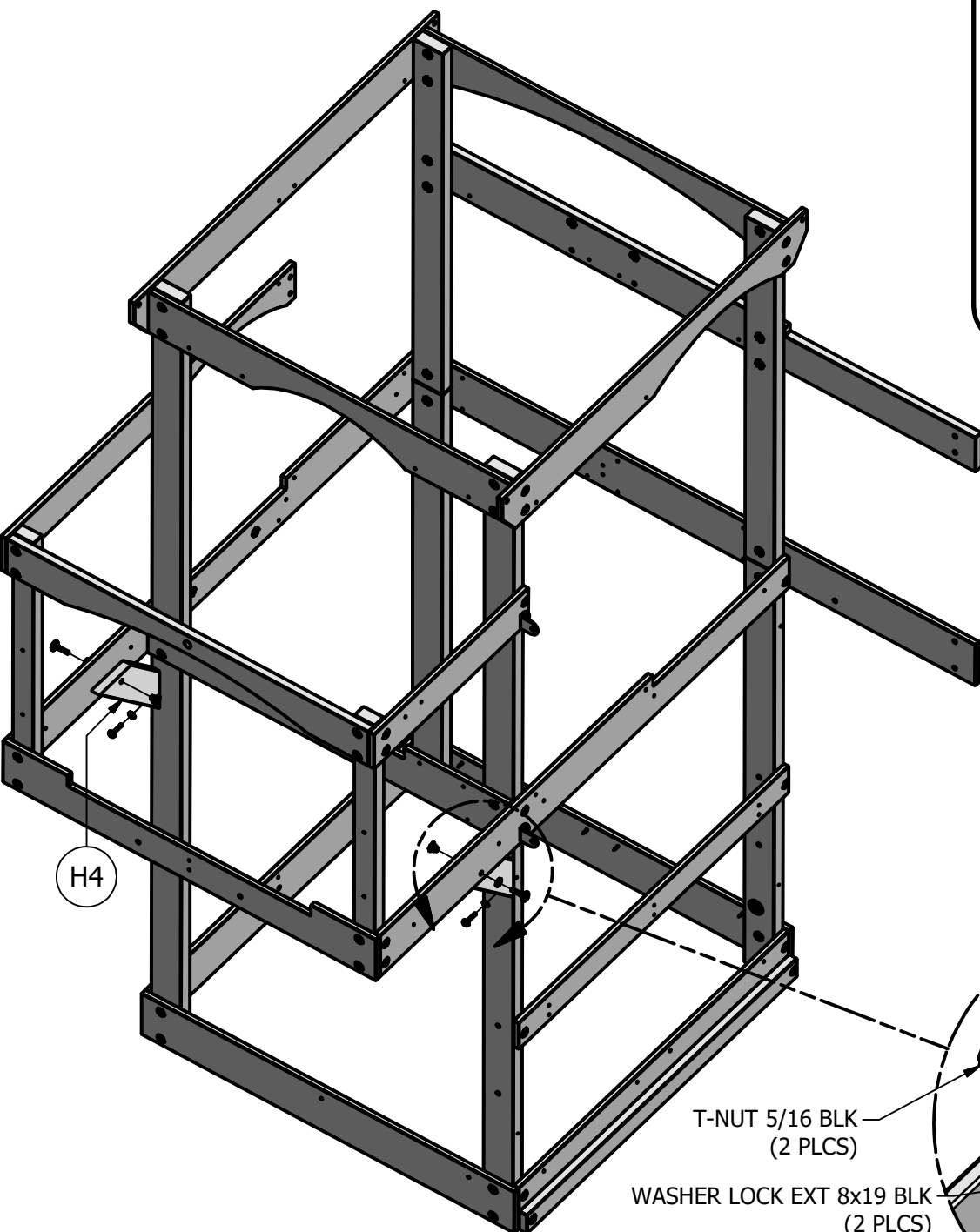
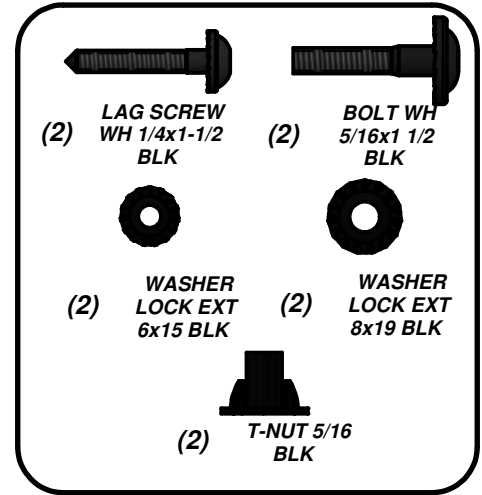

H4

H4

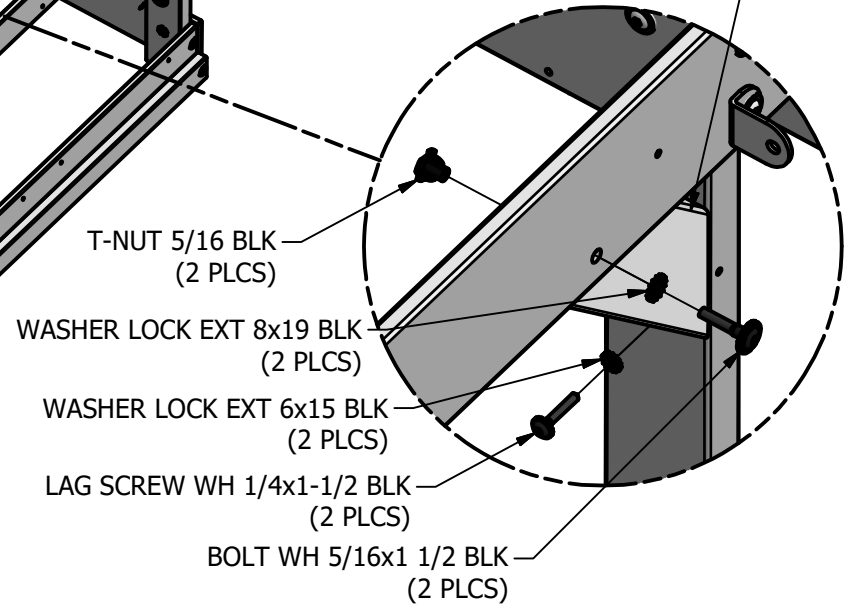



(1) **K9 - LEFT BALCONY WALL RAIL - W4L11124**
5/8"x5 1/4"x20 3/4" (16x134x528)

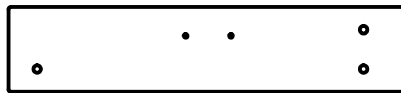

(1) **L3 - WALL RAIL - W4L11140**
5/8"x4 3/8"x20 7/8" (16x112x529)



(2) **N1 - PORCH GROUND BOARD - W4L11127**
5/8"x2 3/8"x21 1/8" (16x60x537)

STEP 10

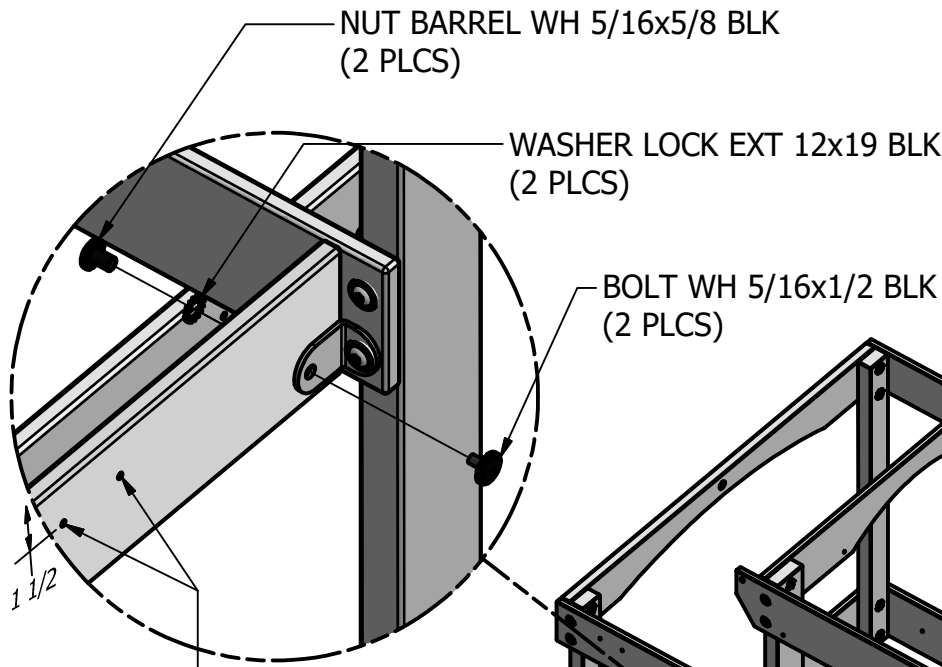

NUT BARREL WH 5/16x5/8 BLK
(2 PLCS)

WASHER LOCK EXT 12x19 BLK
(2 PLCS)

BOLT WH 5/16x1/2 BLK
(2 PLCS)

1 1/2

NOTE HOLES ARE ABOVE CENTER OF BOARD

NOTE SMALL HOLE LOCATION

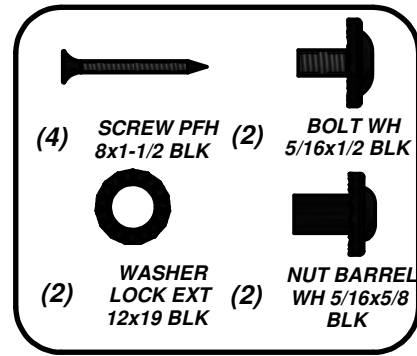

L3

K9

SCREW PFH 8x1-1/2 BLK
(4 PLCS)

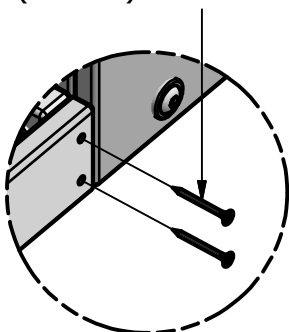

N1

N1



(1) **E5 - RIGHT FRONT BALCONY UPRIGHT - W4L11126**
1 3/8"x3 3/8"x80 3/4" (36x86x2052)

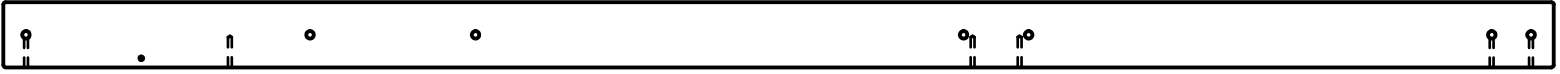

(1) **E11 - RIGHT FRONT BALCONY UPRIGHT - W4L11157**
1 3/8"x3 3/8"x80 3/4" (36x86x2052)

STEP 11

•INSTALL T-NUTS INTO PARTS BEFORE ASSEMBLY OF PARTS.

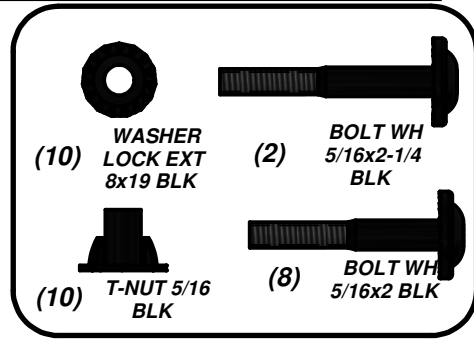

- (10) WASHER LOCK EXT 8x19 BLK
- (2) BOLT WH 5/16x2-1/4 BLK
- (10) T-NUT 5/16 BLK
- (8) BOLT WH 5/16x2 BLK

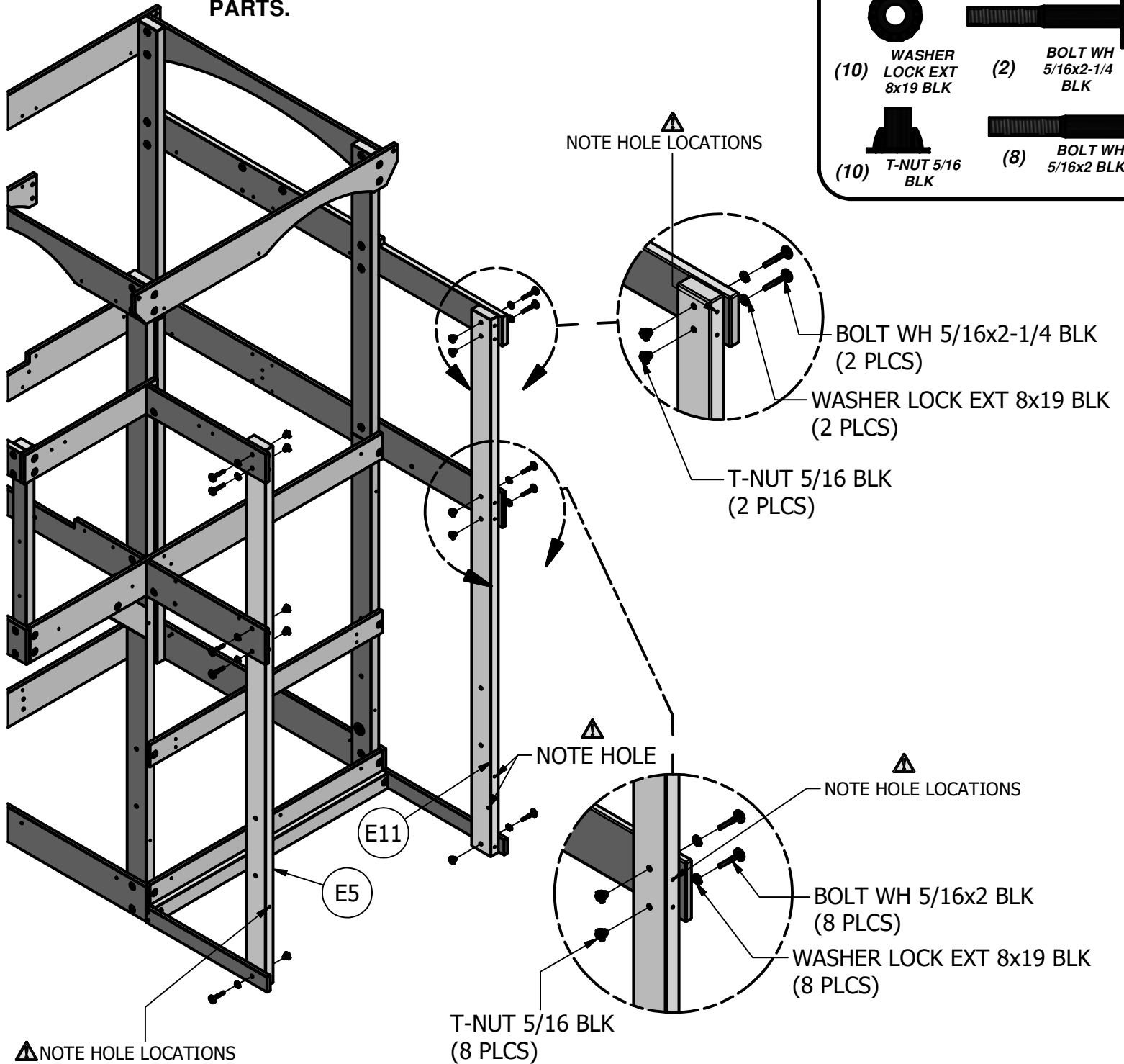



(1) **J2 - PORCH GROUND BOARD - W4L11129**
1"x2 3/8"x40 5/8" (24x60x1032)

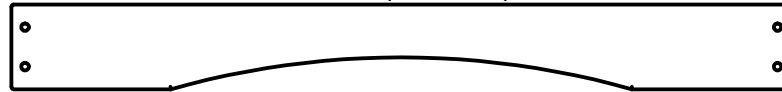

(1) **L1 - ARCHED WALL RAIL - W4L11138**
5/8"x4 3/8"x40 5/8" (16x112x1032)

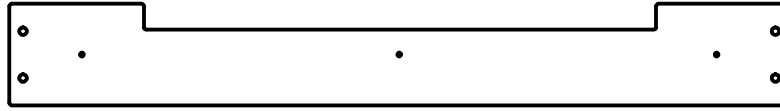

(1) **K10 - FRONT BALCONY WALL RAIL - W4L11125**
5/8"x5 1/4"x40 5/8" (16x134x1032)

STEP 12

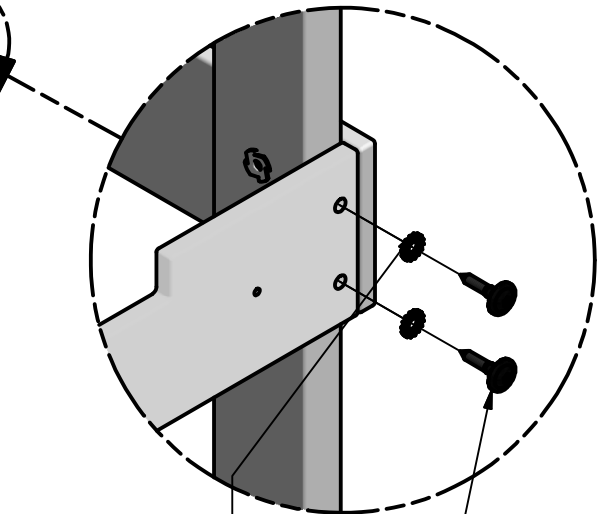
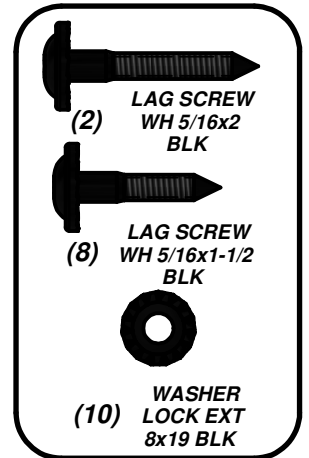
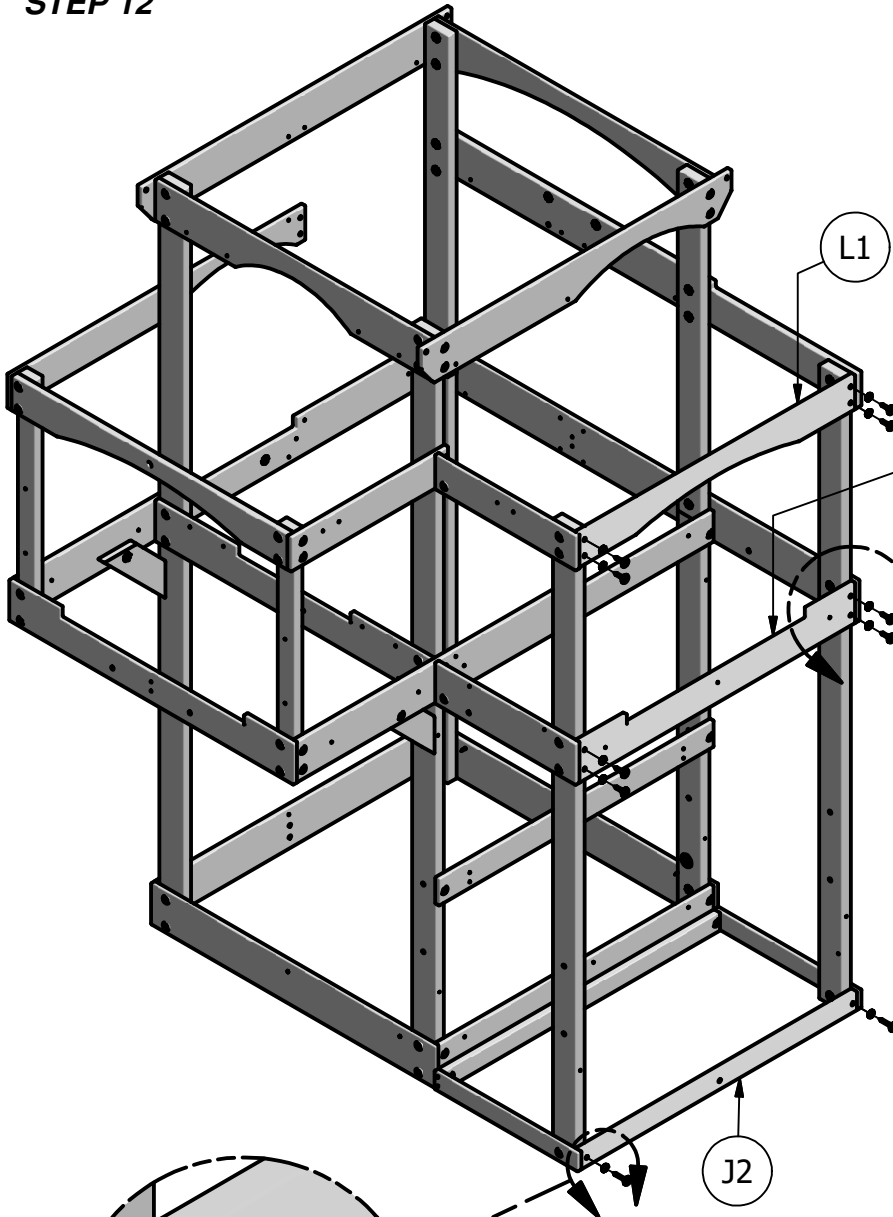

WASHER LOCK EXT 8x19 BLK
(8 PLCS)

LAG SCREW WH 5/16x1-1/2 BLK
(8 PLCS)

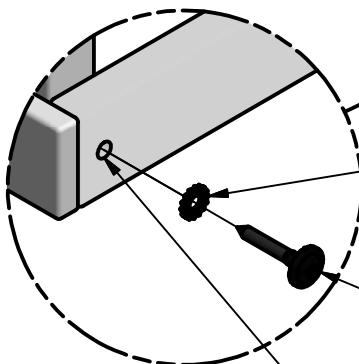

WASHER LOCK EXT 8x19 BLK
(2 PLCS)

LAG SCREW WH 5/16x2 BLK
(2 PLCS)

NOTE PILOT HOLES



(2) **H4 - DECK BRACE - W4L11156**
1"x3 3/8"x12 3/4" (24x86x325)

STEP 13

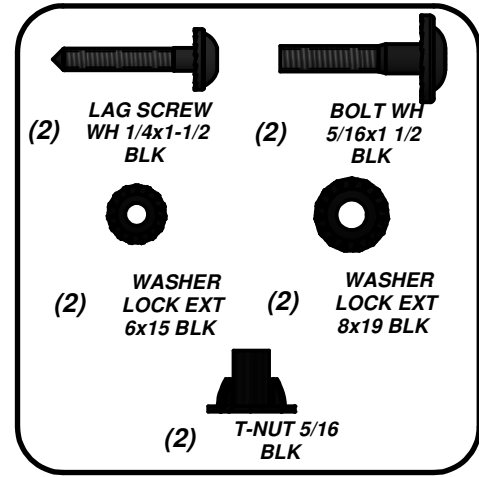
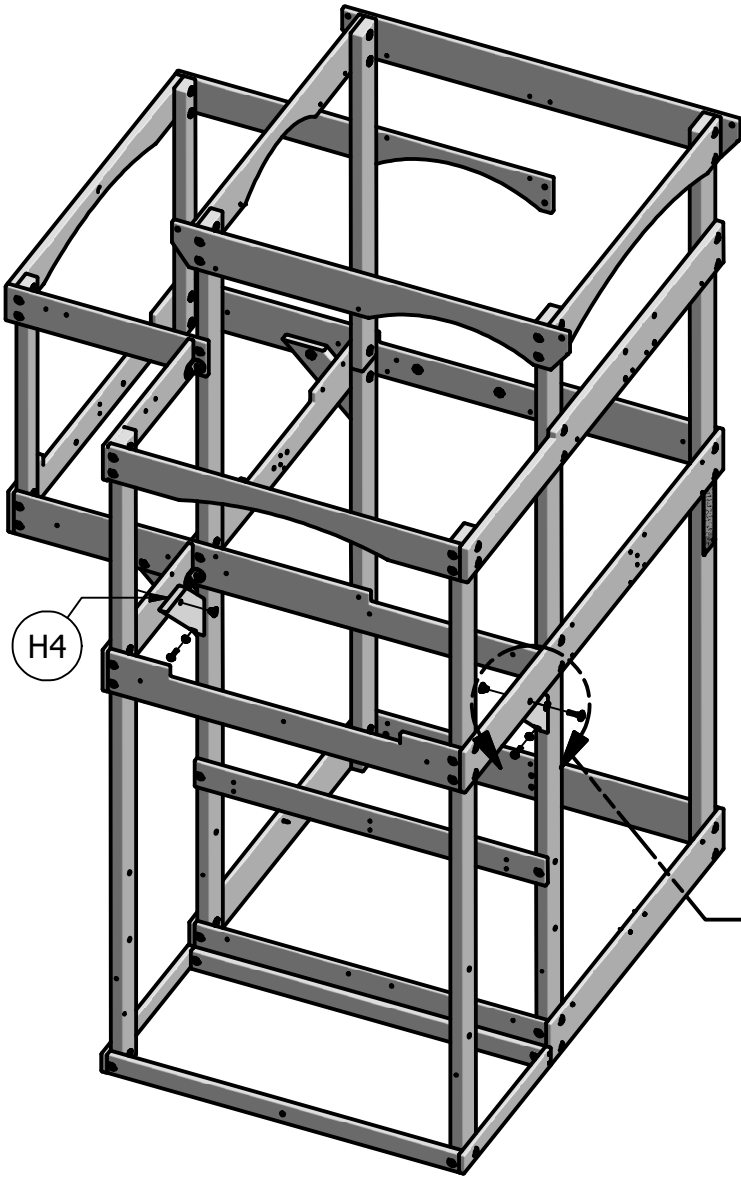

WASHER LOCK EXT 8x19 BLK
(2 PLCS)

T-NUT 5/16 BLK
(2 PLCS)

H4

H4

LAG SCREW WH 1/4x1-1/2 BLK
(2 PLCS)

WASHER LOCK EXT 6x15 BLK
(2 PLCS)

BOLT WH 5/16x1 1/2 BLK
(2 PLCS)



(2) **T1 - SUPPORT BOARD - W4L07599**
1"x1 3/8"x37 5/8" (24x34x957)



(1) **J8 - FLOOR JOIST - W4L07602**
1"x2 3/8"x40 1/2" (24x60x1029)

STEP 14

**INSTALL
CENTER FLOOR SUPPORTS**

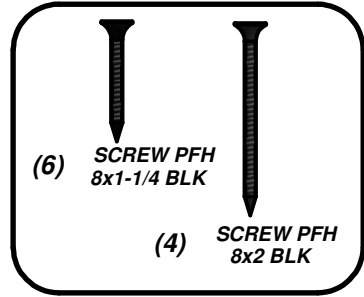
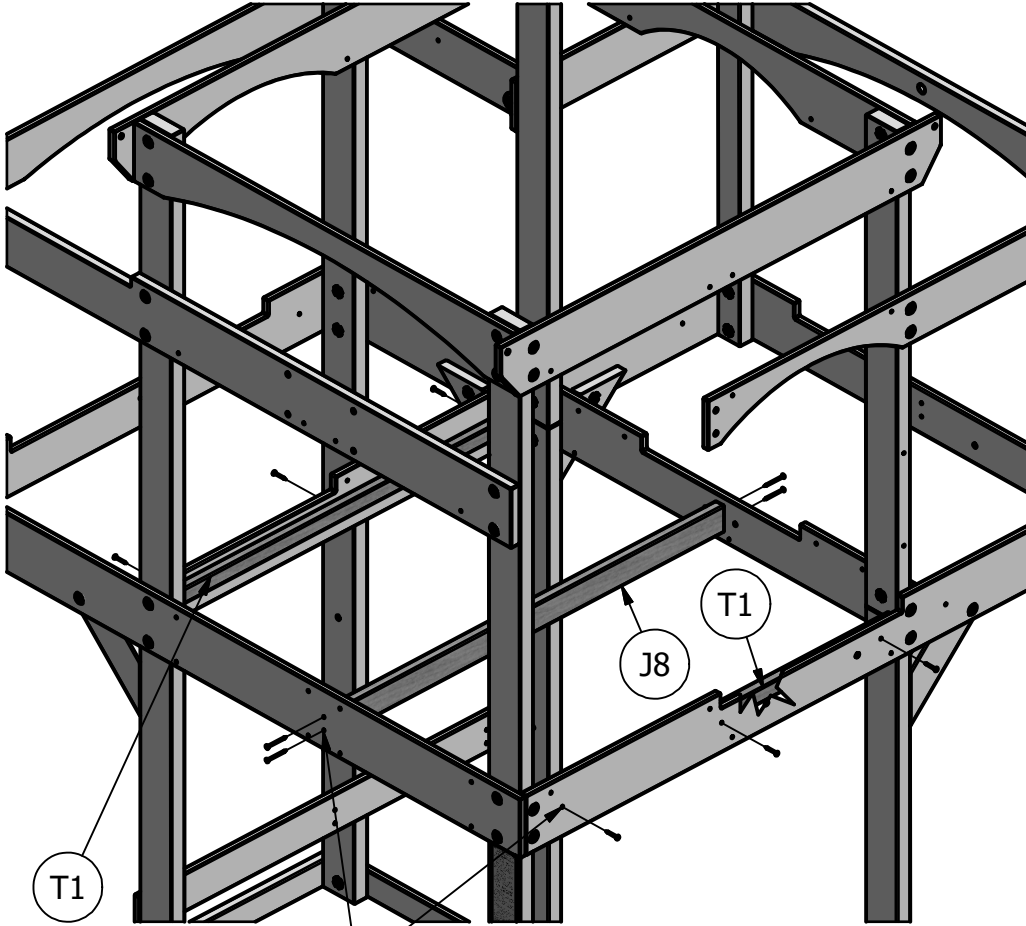

T1

J8

T1

NOTE PILOT HOLES

SCREW PFH 8x1-1/4 BLK
(3 PLCS)

TOP VIEW

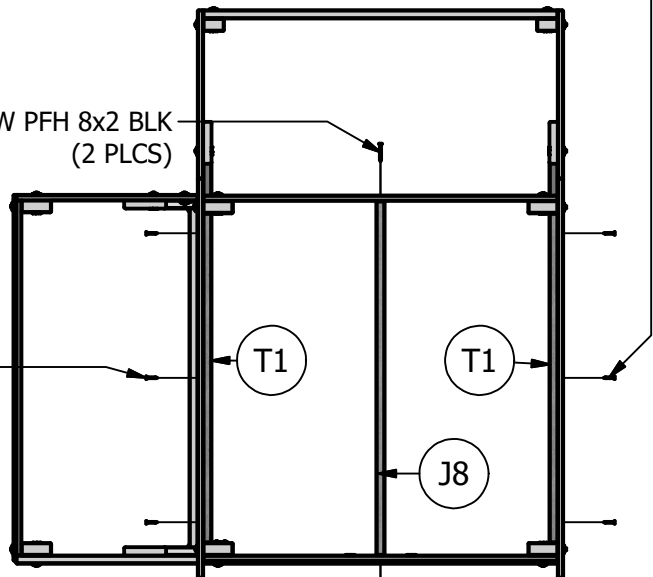

SCREW PFH 8x2 BLK
(2 PLCS)

SCREW PFH 8x1-1/4 BLK
(3 PLCS)

SCREW PFH 8x2 BLK
(2 PLCS)

**SIDE VIEW
SUPPORT PLACEMENT**

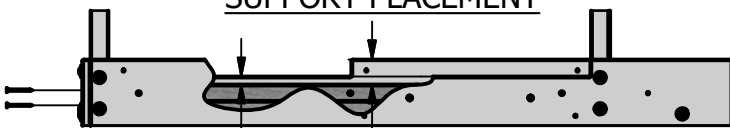

5/8

1 15/16



(2) **T3 - SUPPORT BOARD - W4L07601**
1"x1 3/8"x18 3/4" (24x34x477)

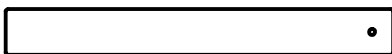

(1) **J9 - FLOOR JOIST - W4L07603**
1"x2 3/8"x20 1/4" (24x60x513)

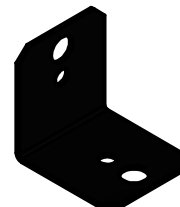

(2) **- 90° L-BRACKET - BLK - A4M00555**

STEP 15

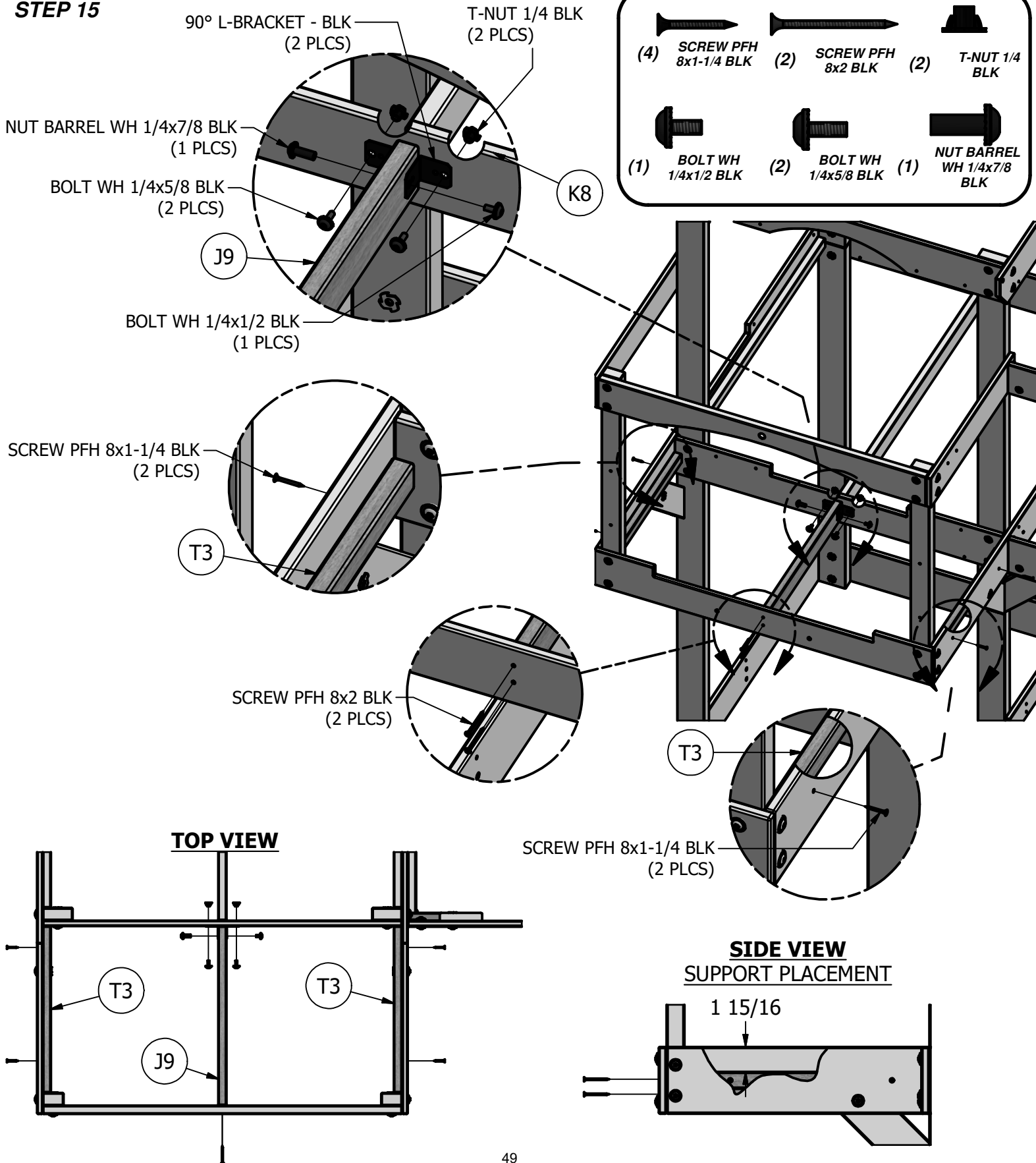

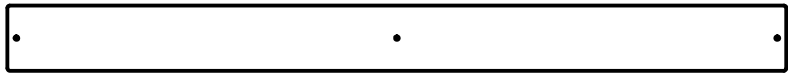

(10) **M11 - FLOOR BOARD - W4L07610**
5/8"x3 3/8"x40 5/8" (16x86x1031)

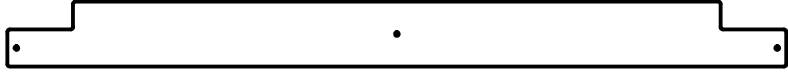

(2) **M12 - FLOOR BOARD - W4L07611**
5/8"x3 3/8"x40 5/8" (16x86x1031)

STEP 16

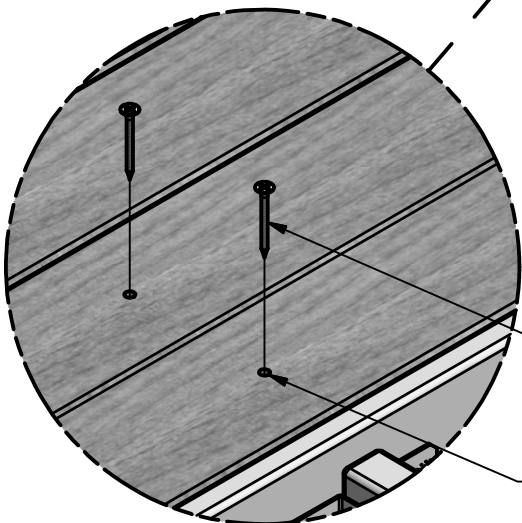
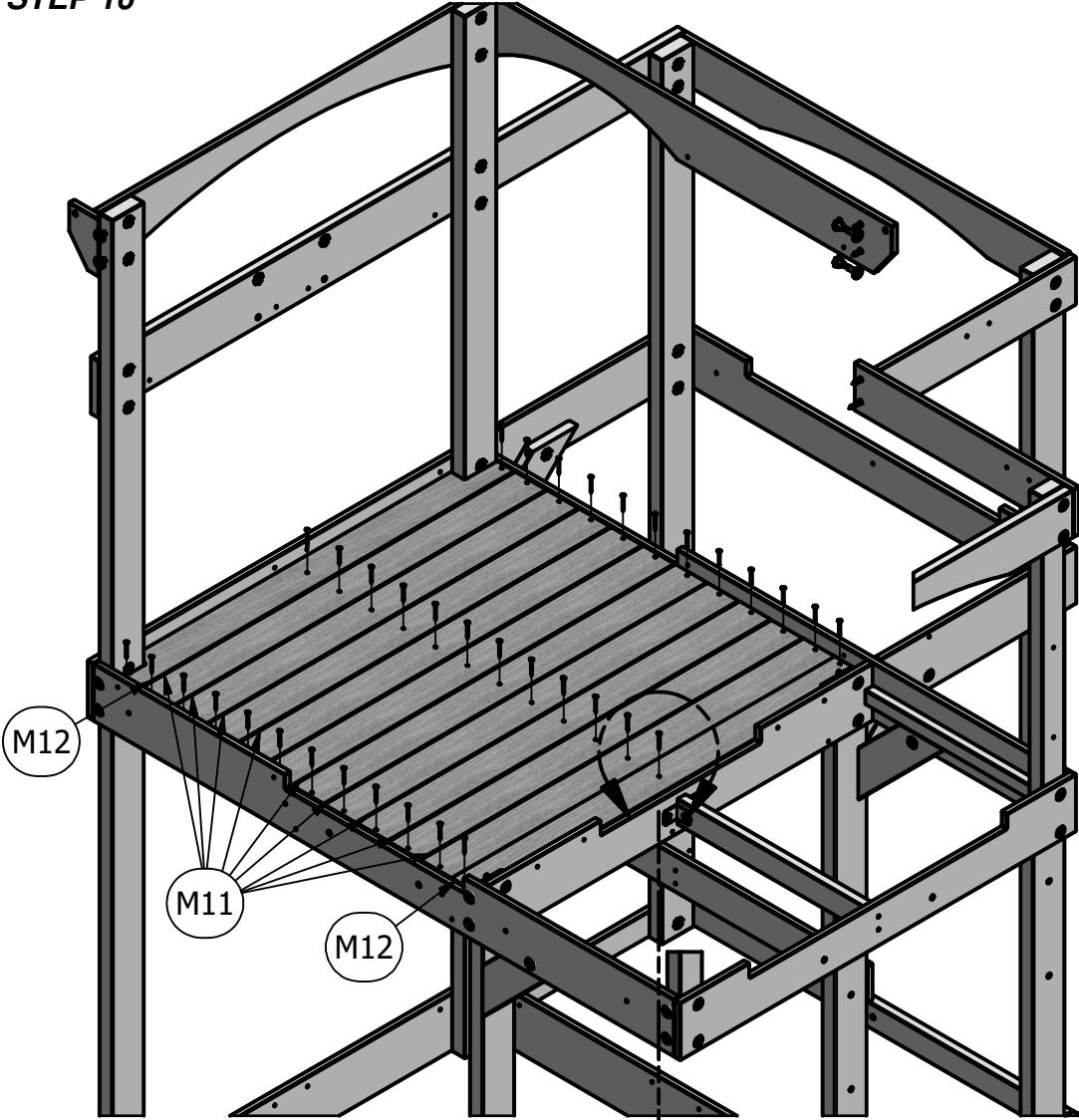
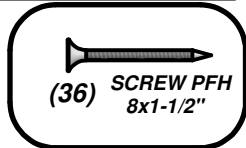

SCREW PFH 8x1-1/2"
(36 PLCS)

NOTE PILOT HOLES

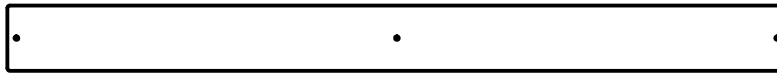

(5) *M11 - FLOOR BOARD - W4L07610*
5/8"x3 3/8"x40 5/8" (16x86x1031)

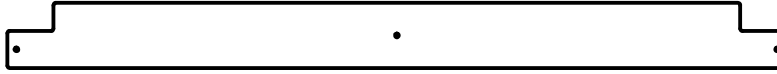

(1) *M10 - FLOOR BOARD - W4L07609*
5/8"x3 3/8"x40 5/8" (16x86x1031)

STEP 17

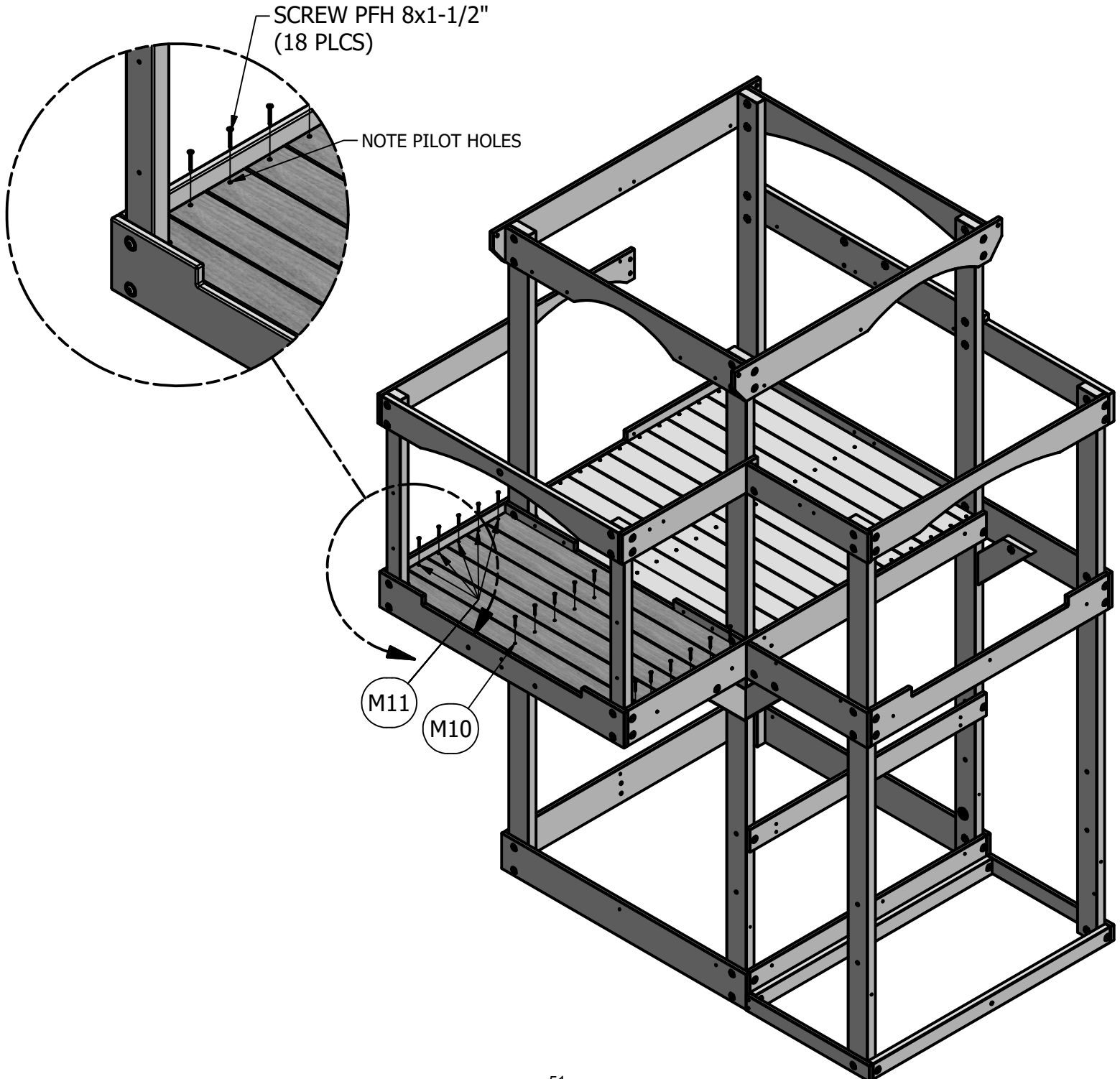
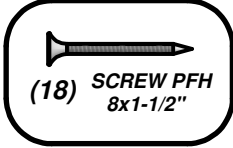

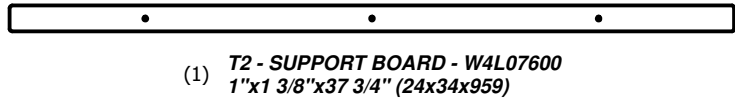
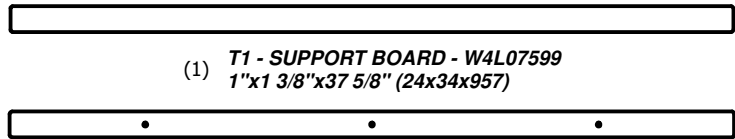

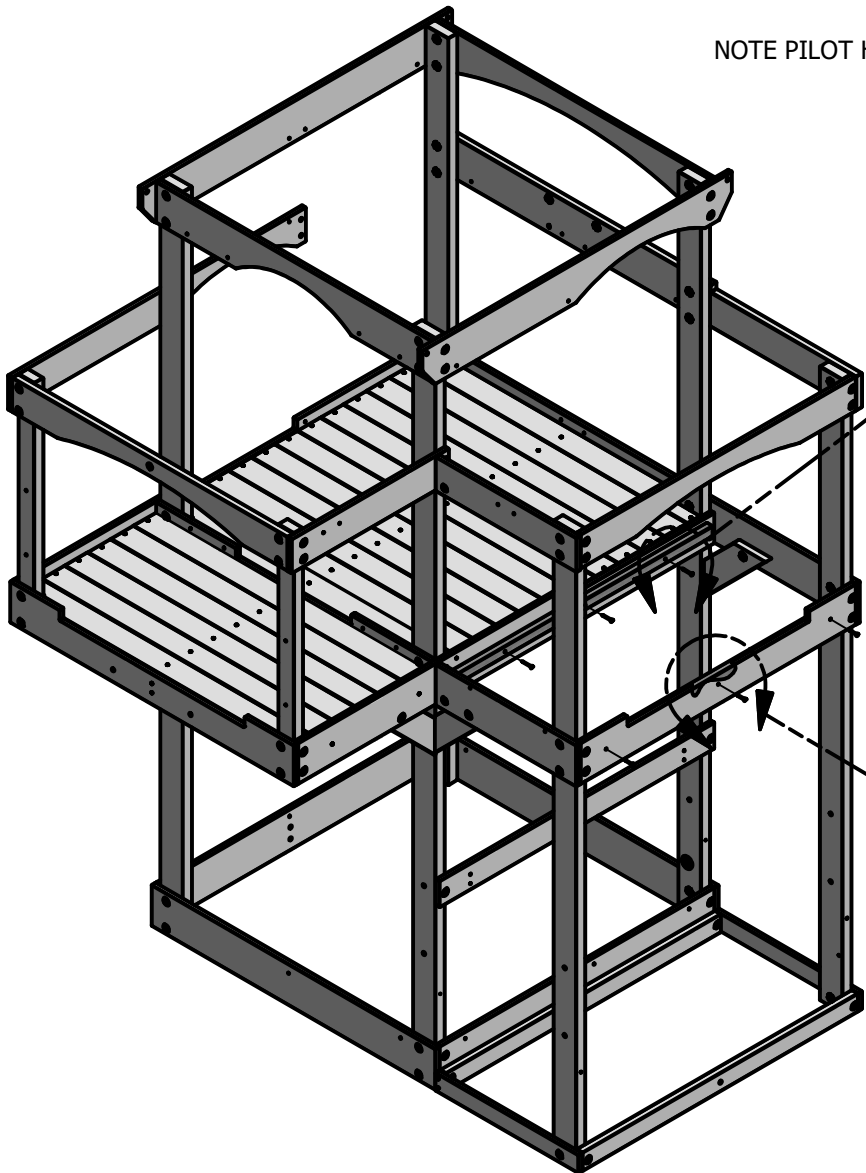

STEP 18

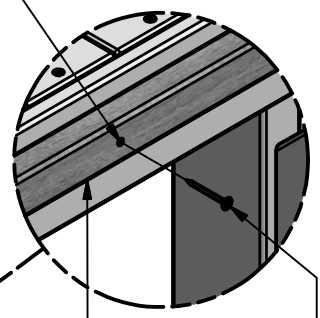

NOTE PILOT HOLES



T2
SCREW PFH 8x1-1/2"
(3 PLCS)



(3) SCREW PFH 8x1-1/2"



(3) SCREW PFH 8x1-1/4 BLK

T1

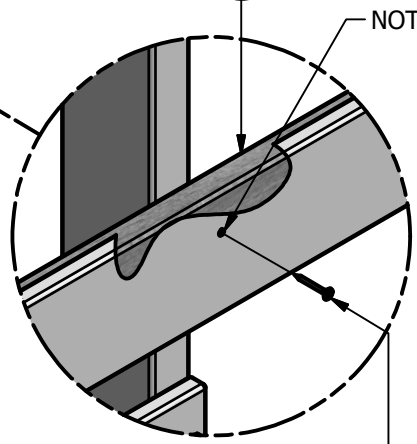

NOTE PILOT HOLES

SCREW PFH 8x1-1/4 BLK
(3 PLCS)

SIDE VIEW

SUPPORT PLACEMENT

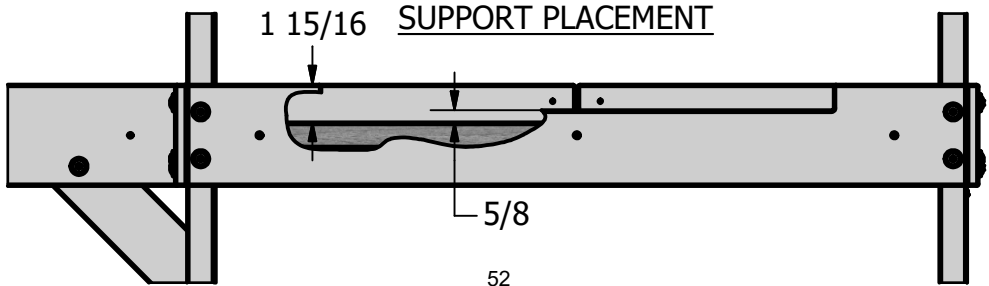



(1) M8 - FLOOR BOARD - W4L07607
5/8"x3 3/8"x20 1/8" (16x86x512)



(10) M9 - FLOOR BOARD - W4L07608
5/8"x3 3/8"x20 1/8" (16x86x512)



(1) M13 - FLOOR BOARD - W4L07671
5/8"x3 3/8"x20 1/8" (16x86x512)

STEP 19

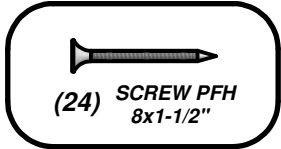

(24) SCREW PFH
8x1-1/2"

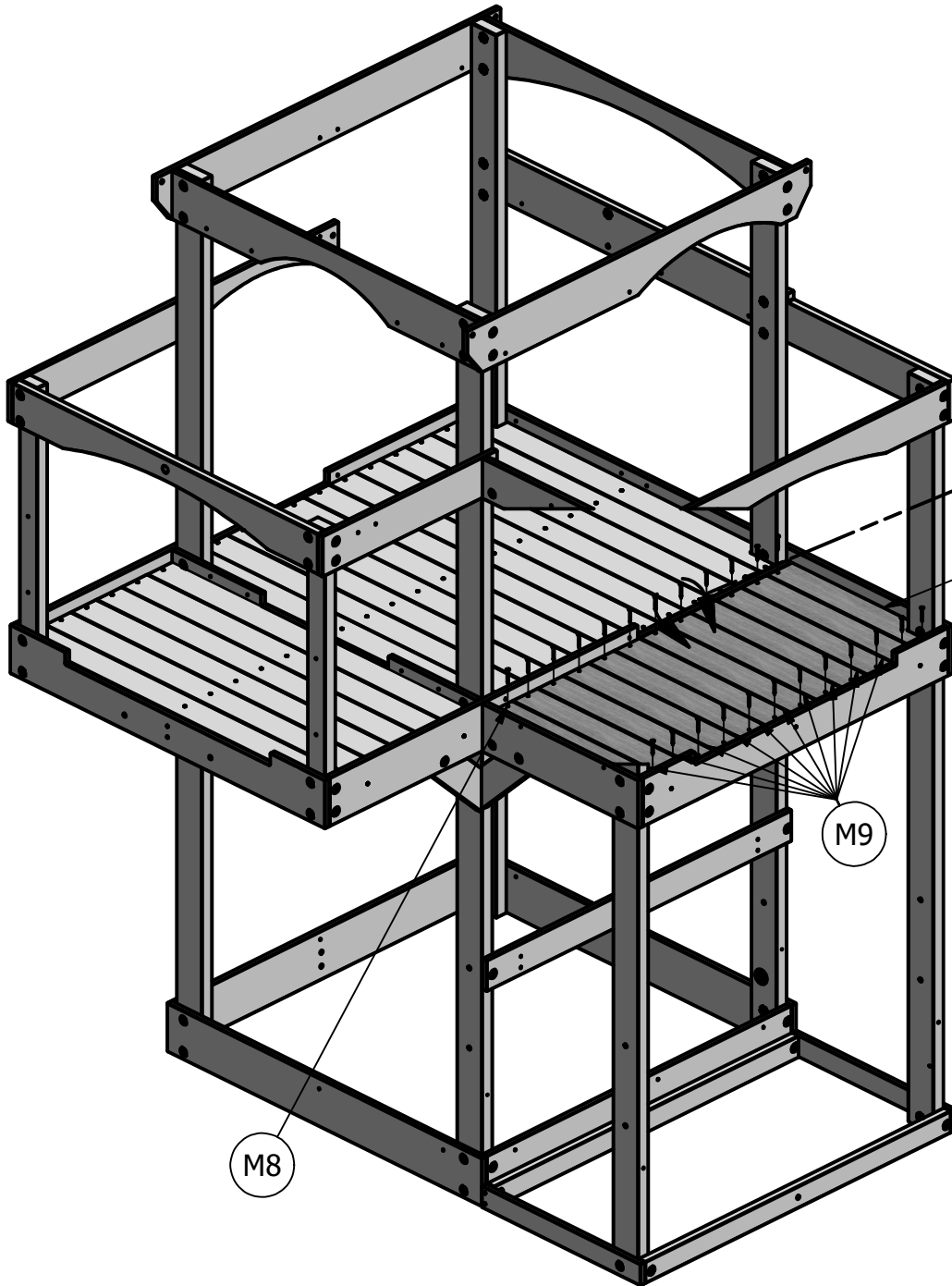

SCREW PFH 8x1-1/2"
(24 PLCS)

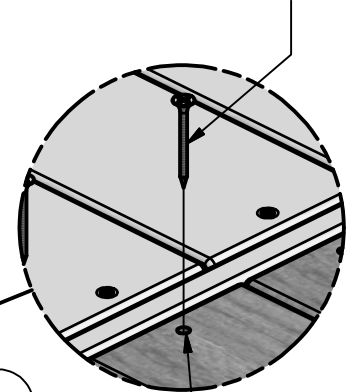

NOTE PILOT HOLES

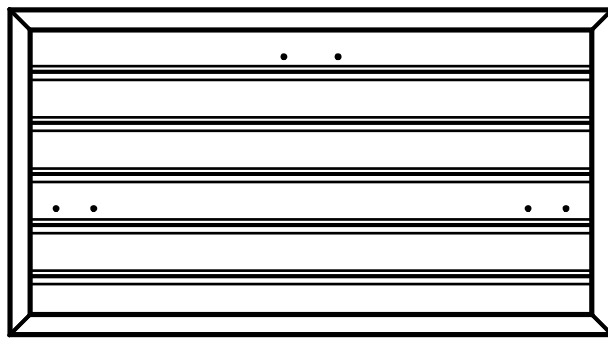

(1) WP1 - FRONT WALL PANEL - W2A02082
1"x20 3/8"x37 3/4" (24x517x958)

STEP 20



SCREW PFH 8x1-1/4 BLK
(3 PLCS)

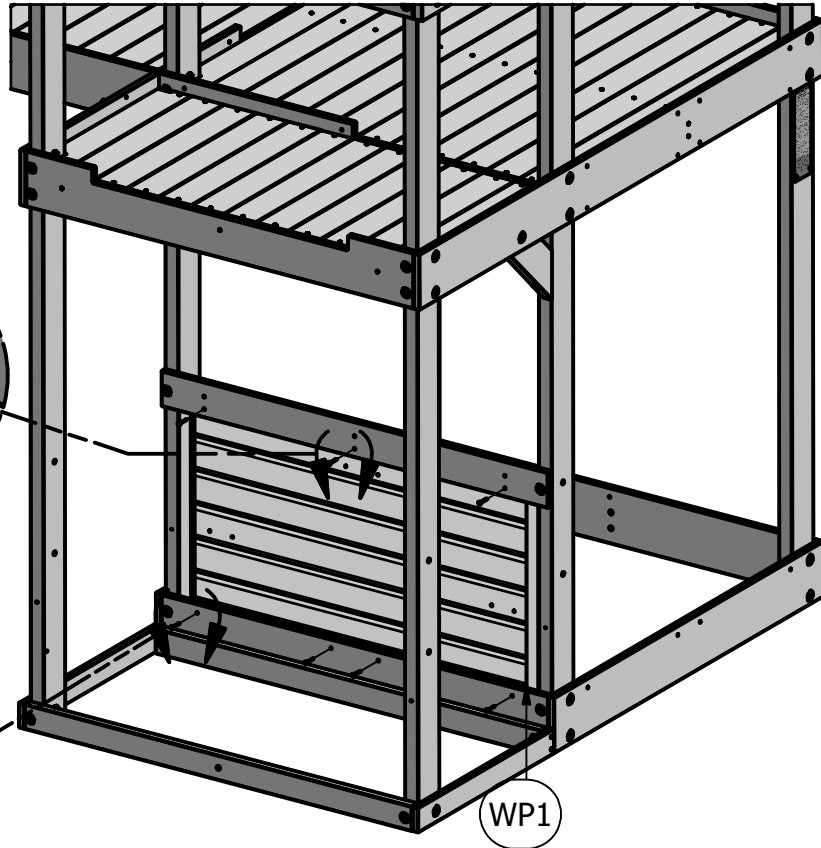
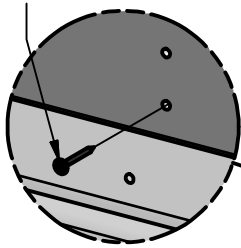

WP1

NOTE PILOT HOLES

SCREW PFH 8x1-1/4 BLK
(4 PLCS)

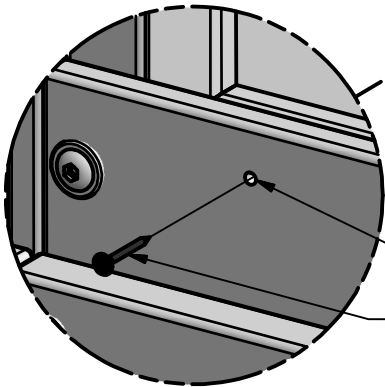

WP1

PANEL PLACEMENT

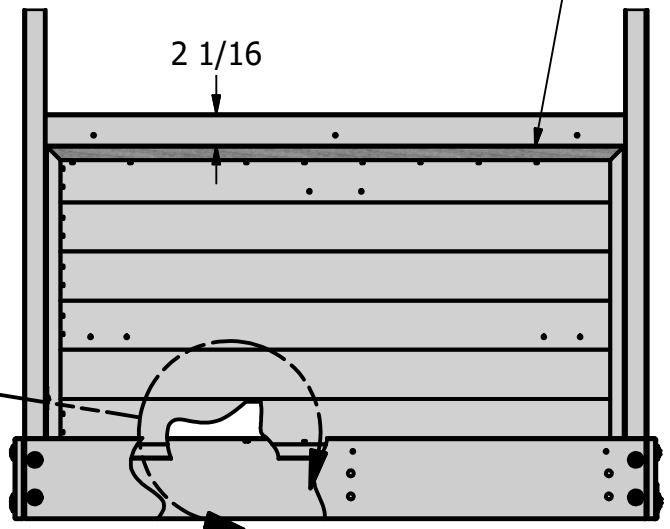

2 1/16

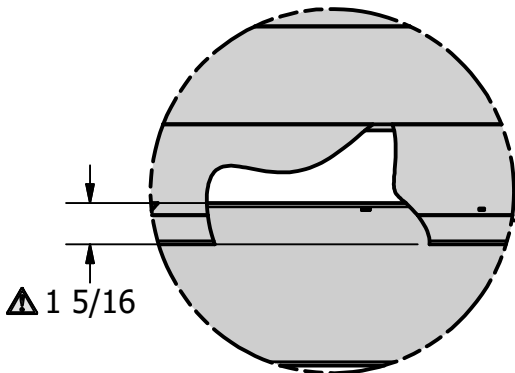

Δ 1 5/16

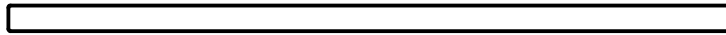

(1) T4 - SUPPORT BOARD - W4L07613
1"x1 3/8"x37 3/4" (24x34x958)

STEP 21

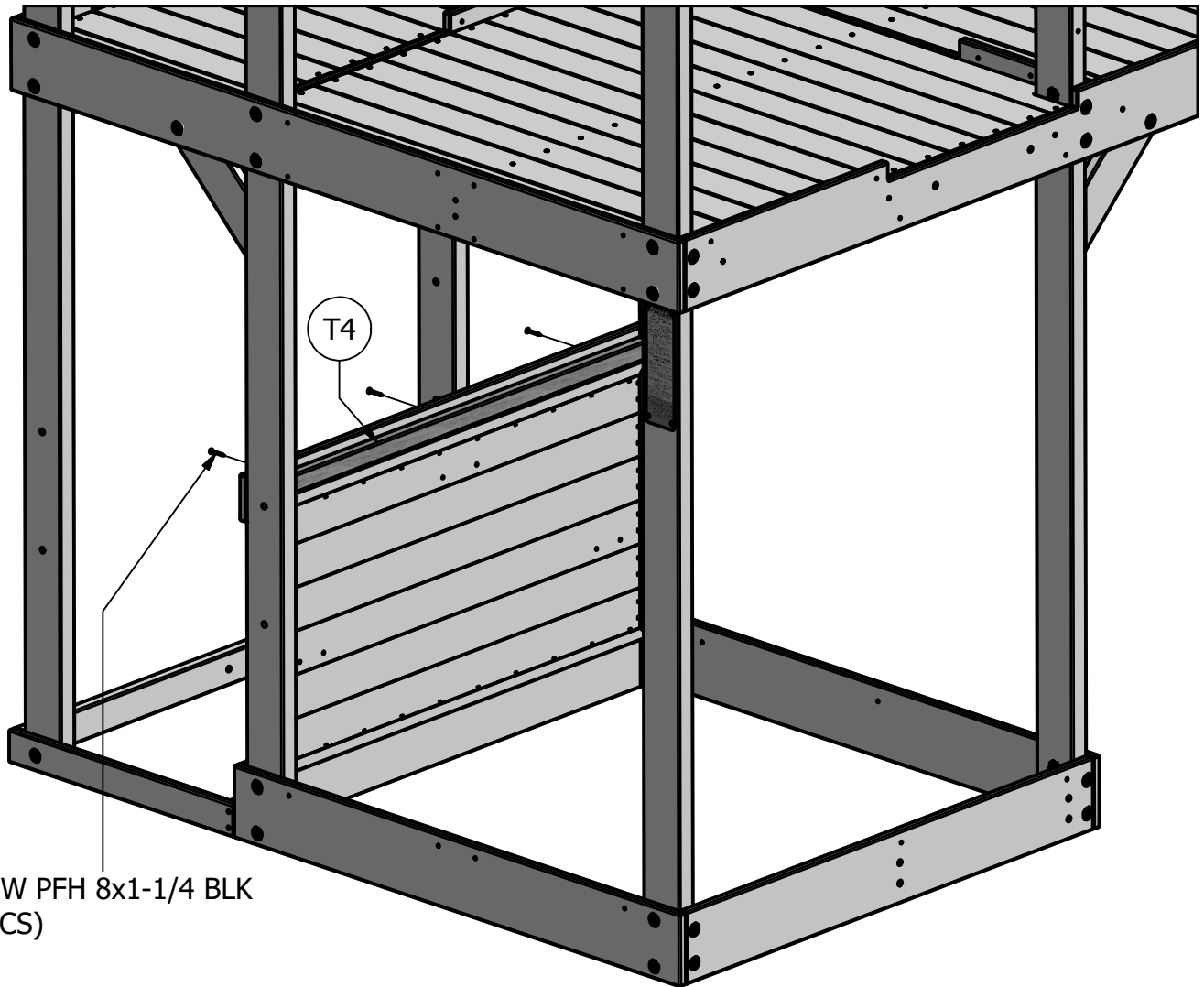
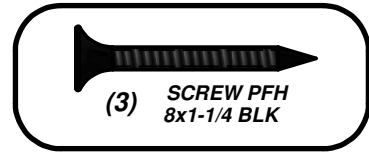

SCREW PFH 8x1-1/4 BLK
(3 PLCS)



(2) **J6 - SUPPORT BLOCK - W4L11153**
1"x2 3/8"x6 1/4" (24x60x160)

STEP 22

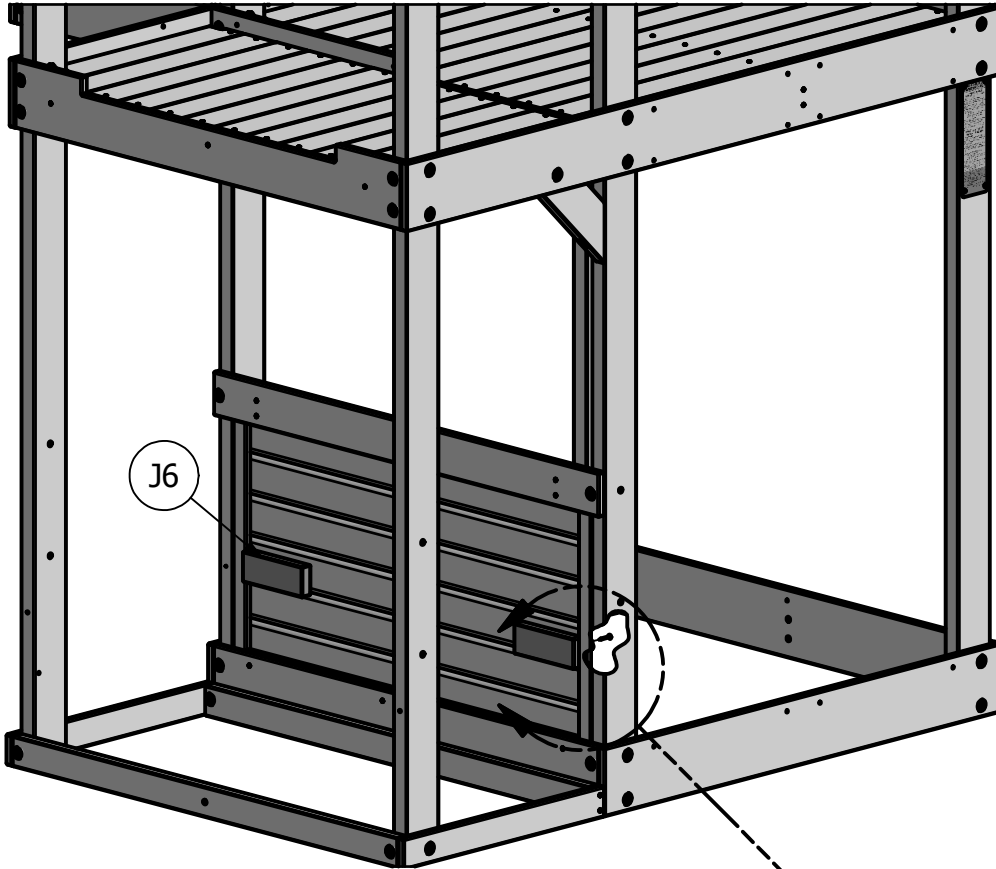
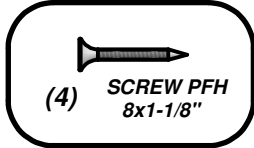

J6

SCREW PFH 8x1-1/8"
(4 PLCS)

J6

5 3/8

NOTE PILOT HOLES

REAR VIEW

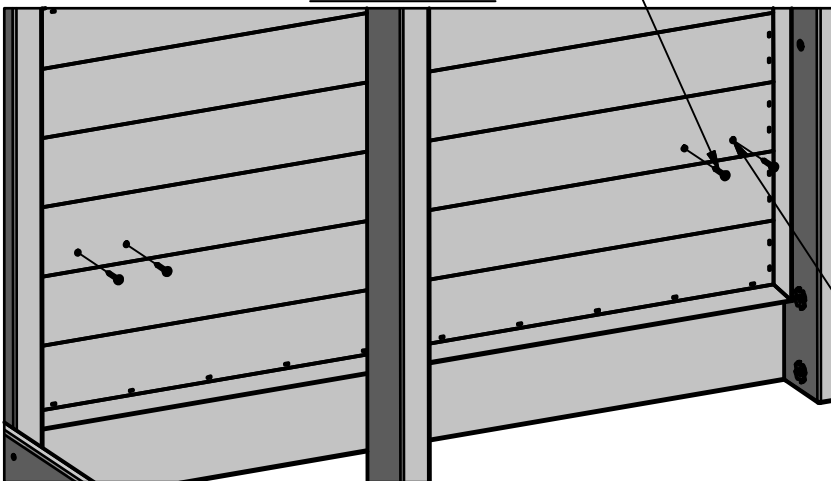



(1) **J7 - SUPPORT BLOCK - W4L11158**
 1"x2 3/8"x3 3/8" (24x60x86)



(1) **H1 - TABLE SUPPORT - W4L11147**
 1"x3 3/8"x22 3/8" (24x86x567)

STEP 23

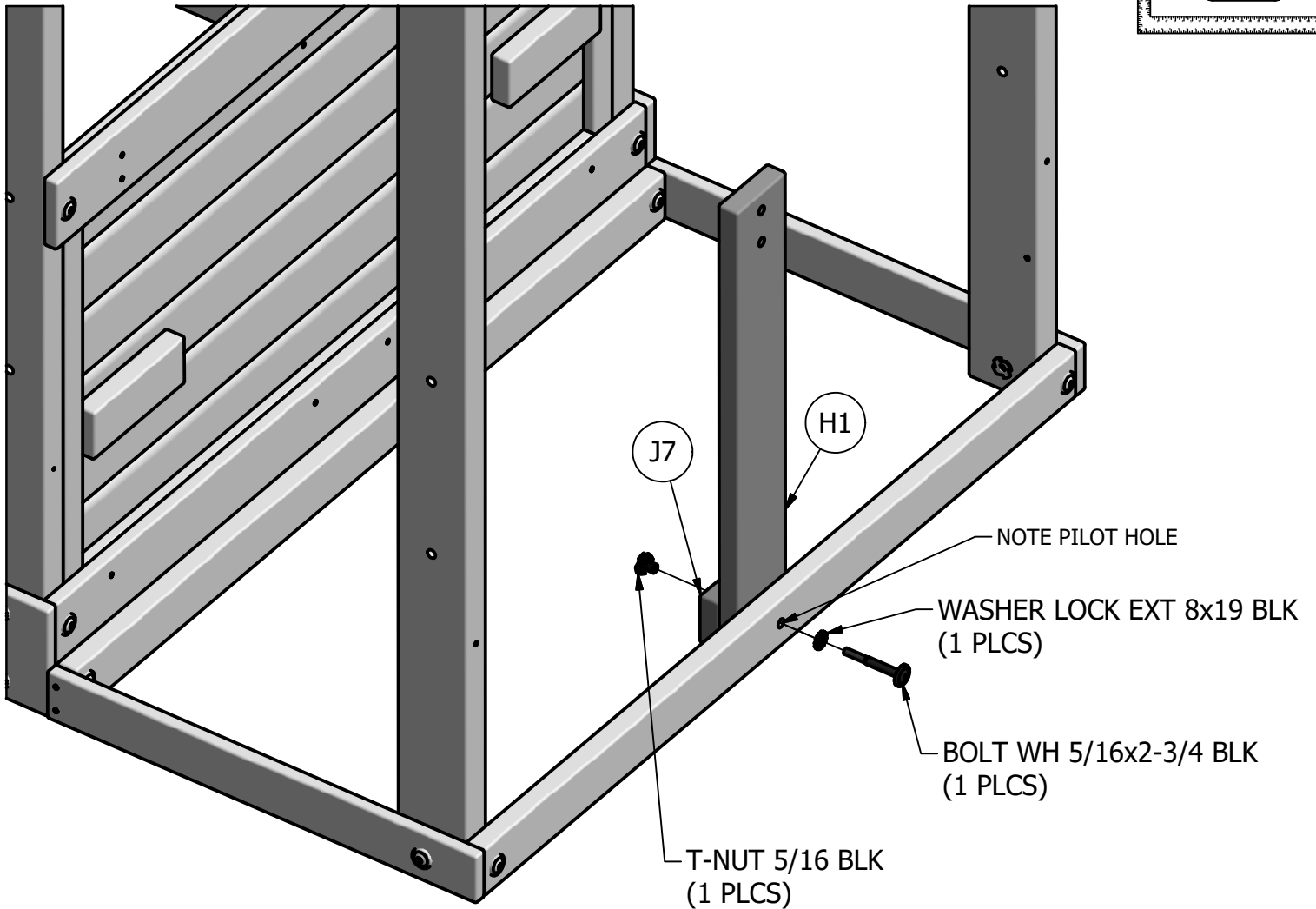
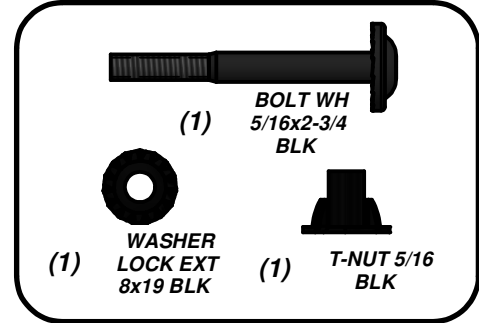



(1) M5 - FLOOR BOARD - W4L07598
5/8"x3 3/8"x19 1/4" (16x86x488)



(8) M4 - FLOOR BOARD - W4L07597
5/8"x3 3/8"x21 1/8" (16x86x537)

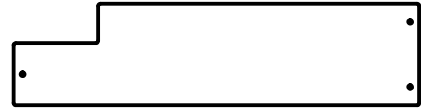

(2) K17 - FLOOR BOARD - W4L07596
5/8"x5 1/4"x21 1/8" (16x134x537)

STEP 24

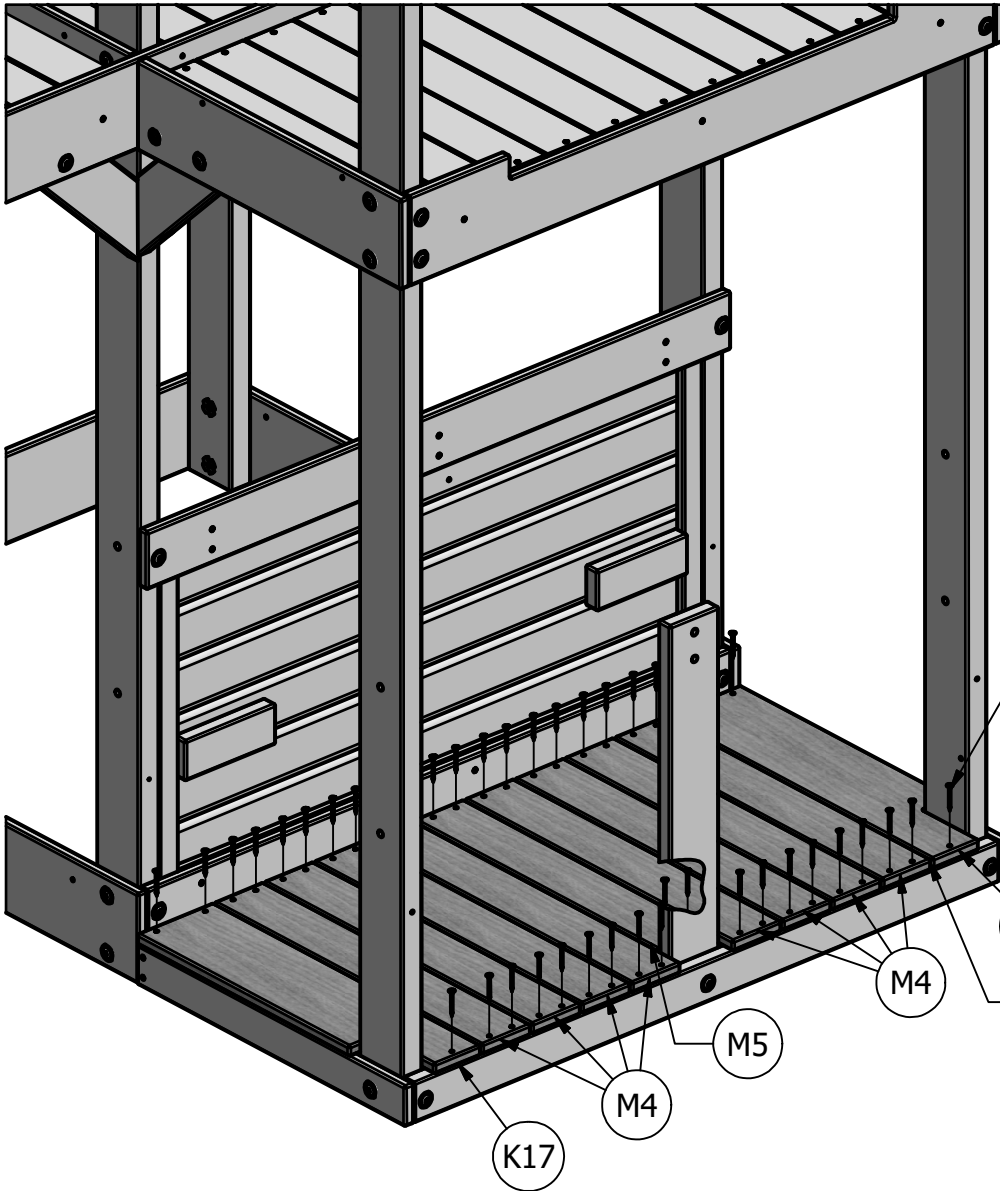
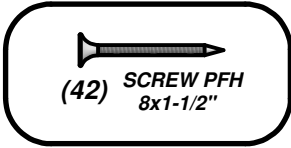

SCREW PFH 8x1-1/2"
(42 PLCS)

EVENLY SPACE ALL
FLOOR BOARDS.



(2) **J3 - BENCH SUPPORT - W4L11150**
1"x2 3/8"x9" (24x60x230)



(2) **J4 - ANGLE BRACE - W4L11151**
1"x2 3/8"x10" (24x60x254)



(2) **J5 - SUPPORT BLOCK - W4L11152**
1"x2 3/8"x2 7/8" (24x60x72)

STEP 25

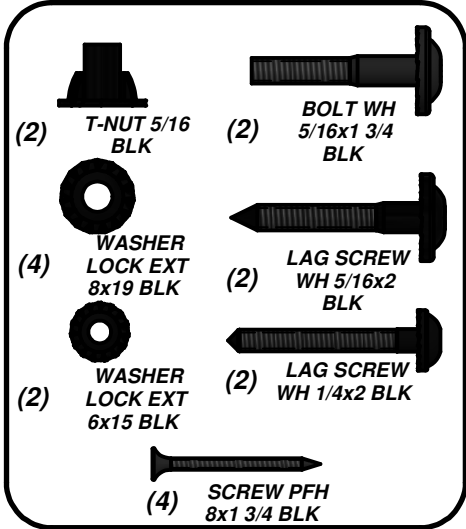
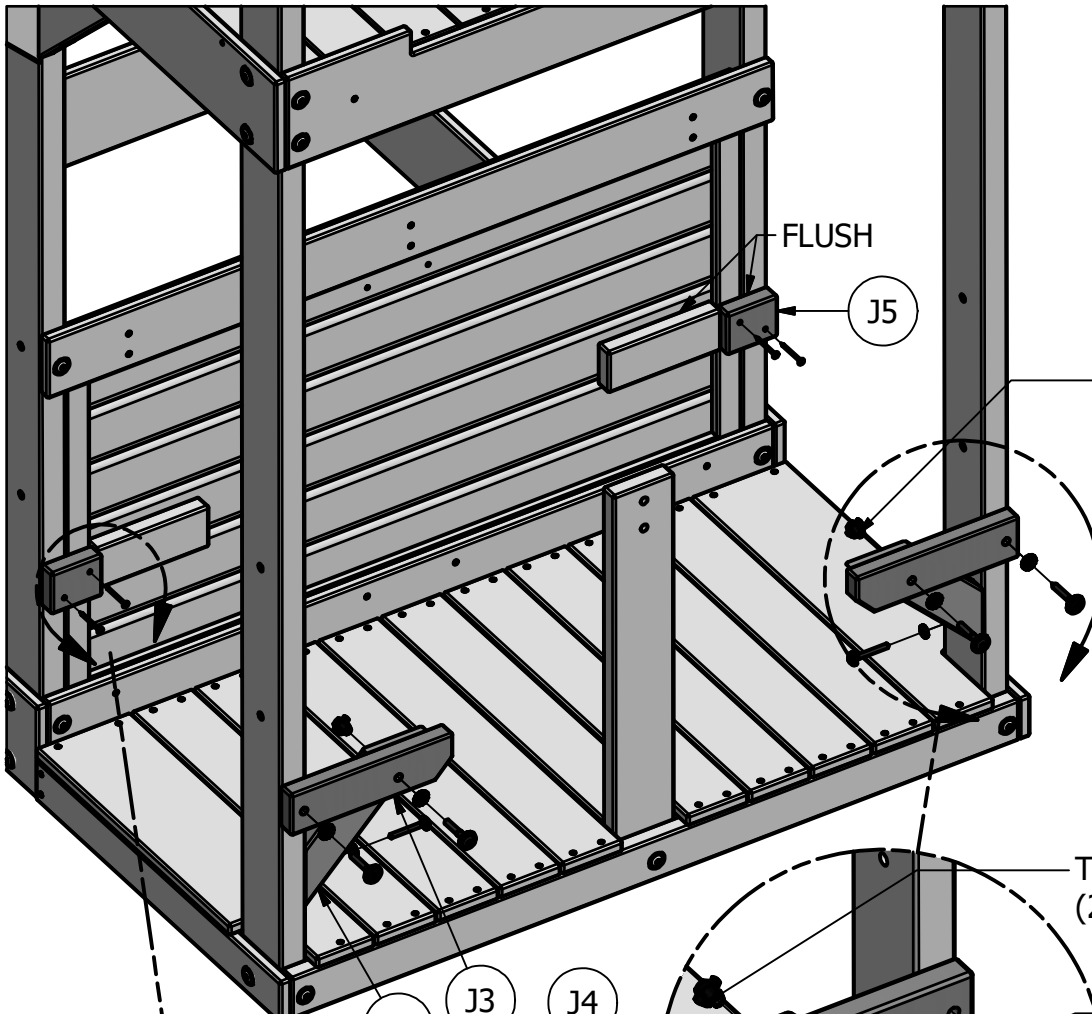

T-NUT 5/16 BLK
(2 PLCS)

T-NUT 5/16 BLK
(2 PLCS)

WASHER LOCK EXT 8x19 BLK
(4 PLCS)

LAG SCREW WH 5/16x2 BLK
(2 PLCS)

RIGHT FRONT BALCONY UPRIGHT
(2 PLCS)

WASHER LOCK EXT 6x15 BLK
(2 PLCS)

LAG SCREW WH 1/4x2 BLK
(2 PLCS)

SCREW PFH 8x1 3/4 BLK
(4 PLCS)

NOTE PILOT HOLE

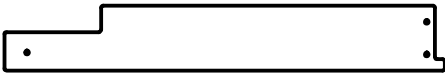

(2) **M2 - BENCH BOARD - W4L07591**
5/8"x3 3/8"x23" (16x86x583)

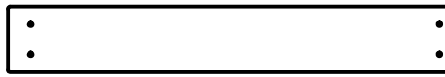

(2) **M3 - BENCH BOARD - W4L07593**
5/8"x3 3/8"x23" (16x86x583)



(2) **N3 - BENCH BOARD - W4L07592**
5/8"x2 3/8"x23" (16x60x583)

STEP 26

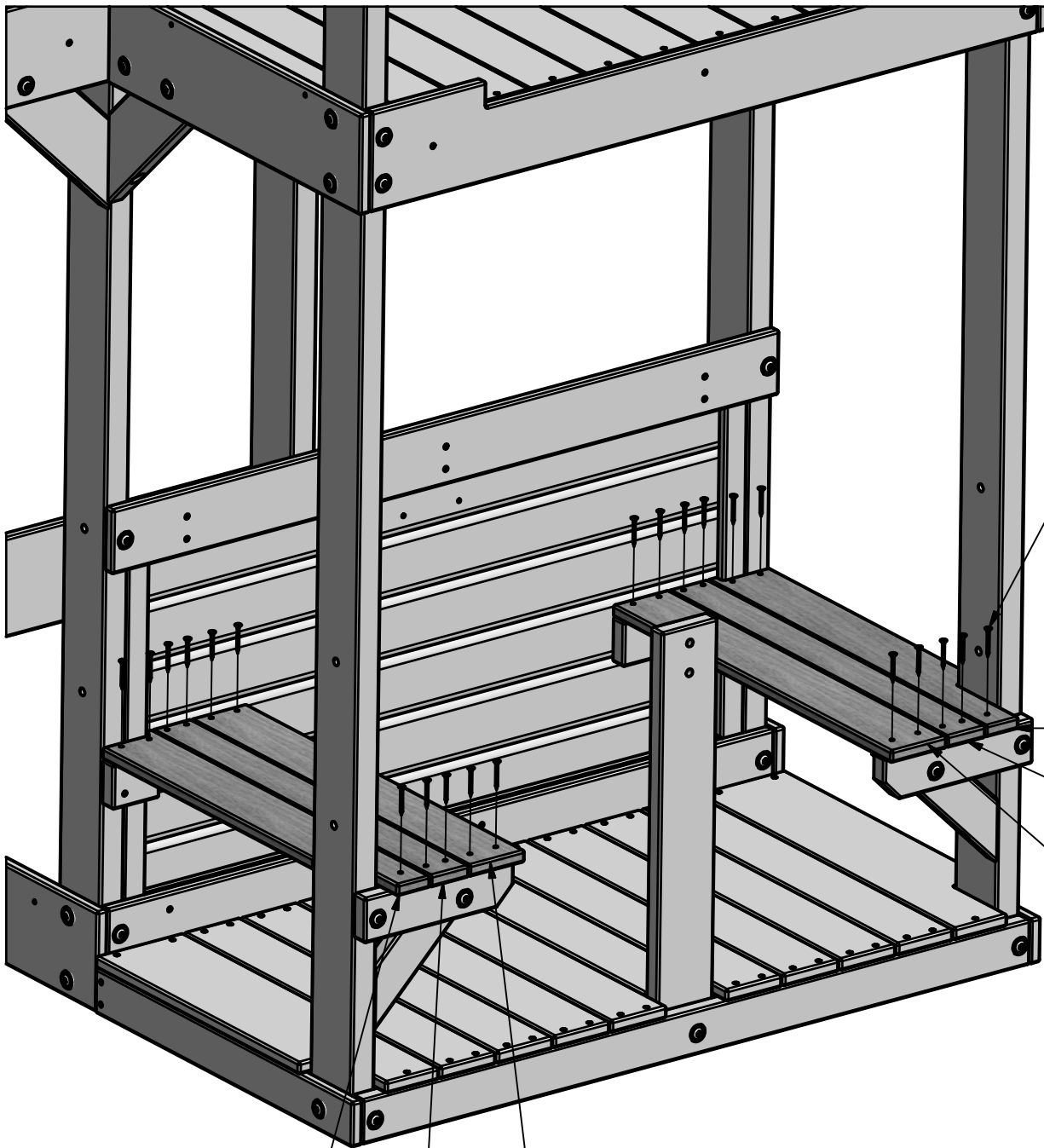
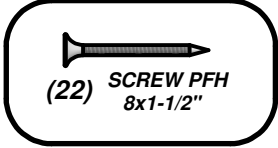

SCREW PFH 8x1-1/2"
(22 PLCS)

M2

N3

M3

M2

N3

M3



(2) **M3 - BENCH BOARD - W4L07593**
5/8"x3 3/8"x23" (16x86x583)

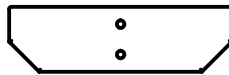

(1) **H2 - TABLE SUPPORT - W4L11148**
1"x3 3/8"x11 5/8" (24x86x295)



(1) **H3 - TABLE SUPPORT - W4L11149**
1"x3 3/8"x11 5/8" (24x86x295)



(1) **K16 - TABLE BOARD - W4L07594**
5/8"x5 1/4"x23" (16x134x583)

STEP 27

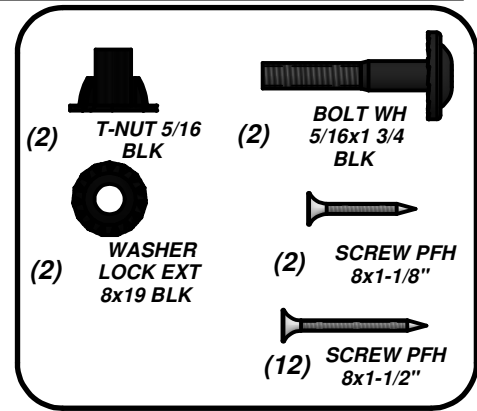
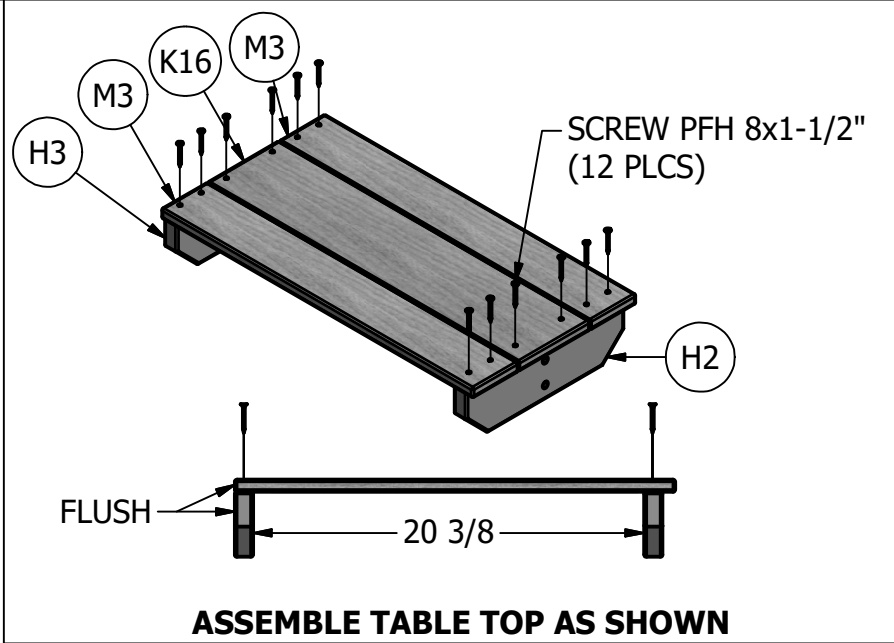

•INSTALL T-NUTS INTO PARTS BEFORE ASSEMBLY OF PARTS

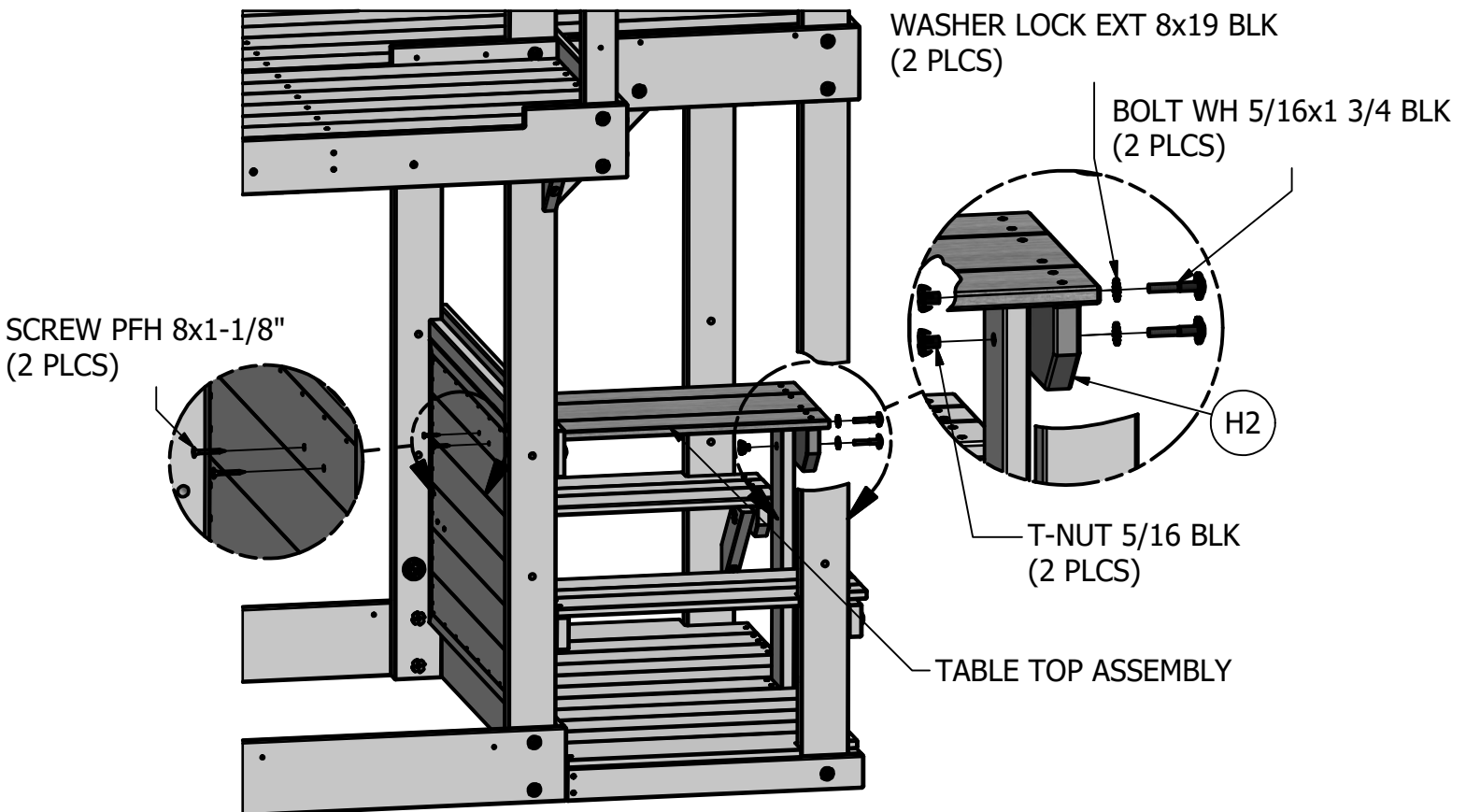

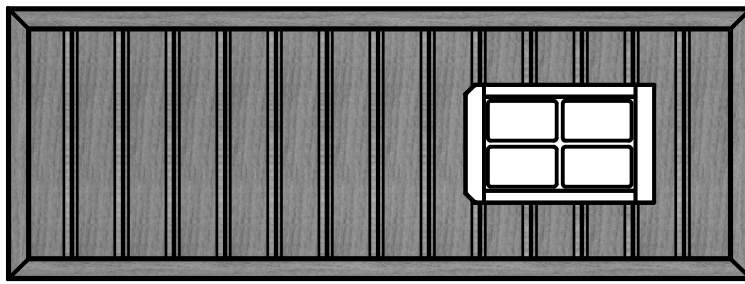

(2) WP2 - RIGHT LOWER WALL PANEL - W2A02083
 1"x16 7/8"x46 1/2" (24x430x1181)

STEP 28

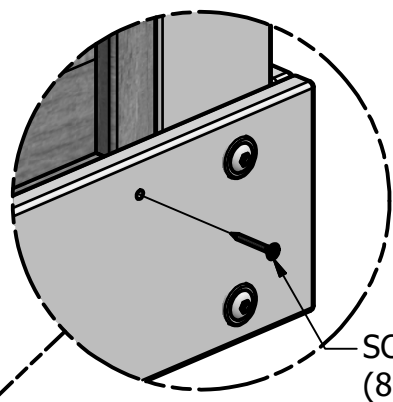
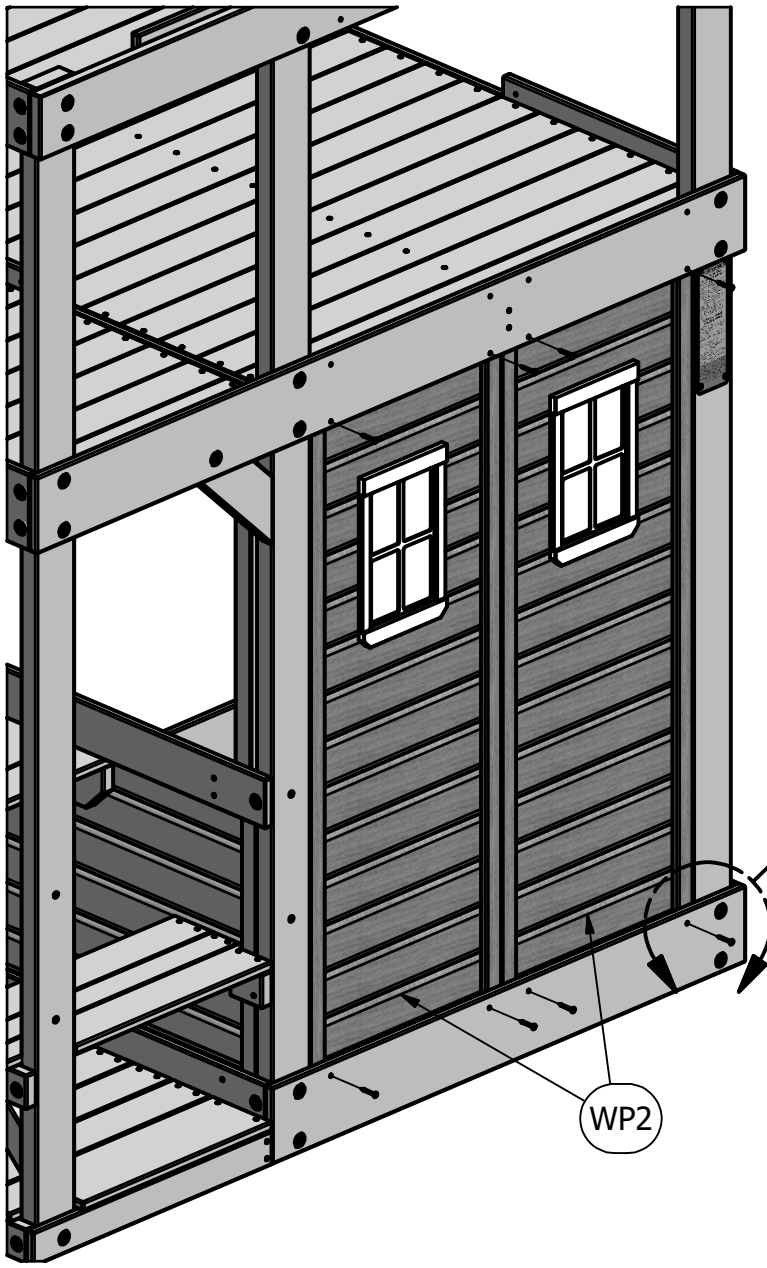
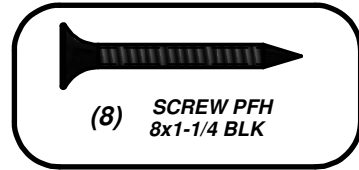

SCREW PFH 8x1-1/4 BLK
 (8 PLCS)

WP2

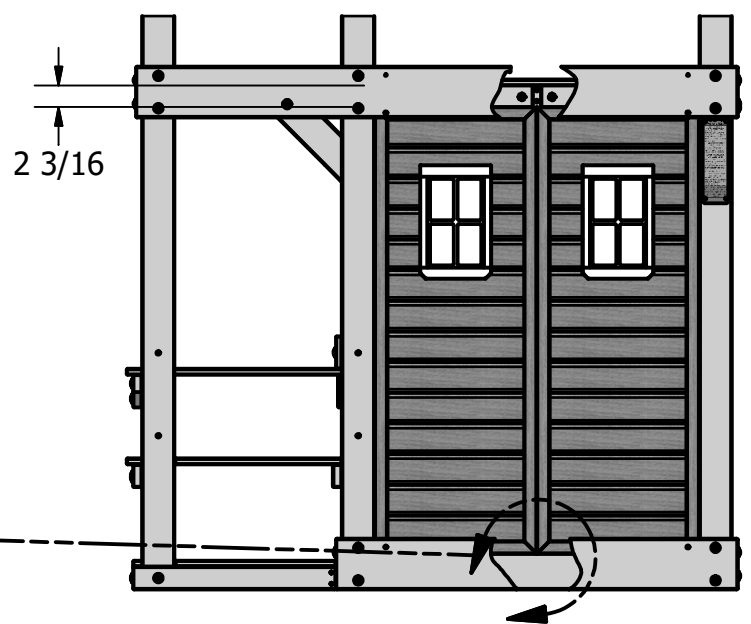

2 3/16

3 9/16

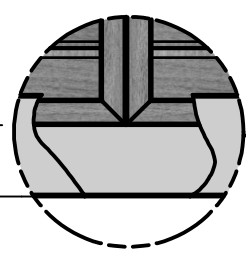

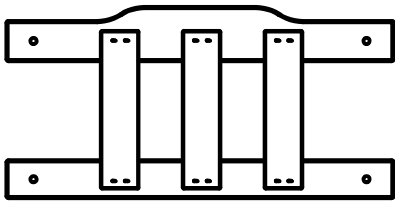

(1) WP10 - BENCH BACK ASSEMBLY - W2A02081
1 1/8"x11 7/8"x17 5/8" (27x303x615)



(1) F3 - SUPPORT BLOCK - W4L11159
1 3/8"x2 3/8"x9 1/4" (36x60x234)

STEP 29

NOTE PILOT HOLES

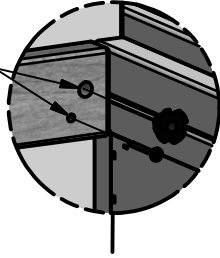

REAR VIEW

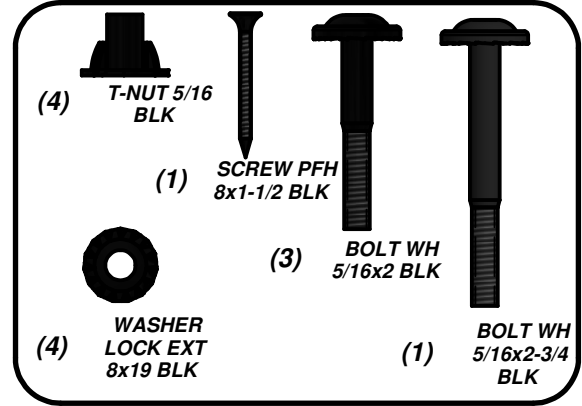
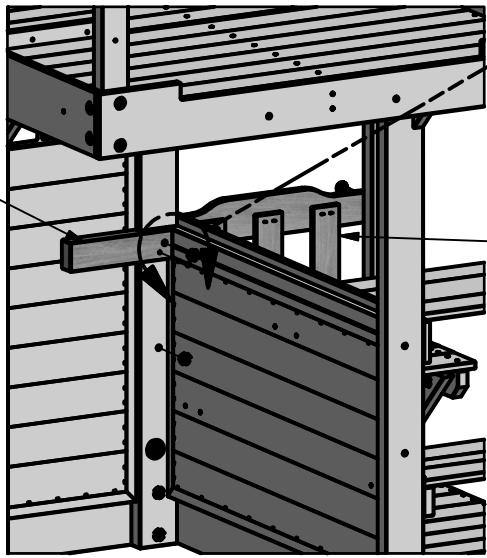

F3

WP10

NOTE PILOT HOLES

BOLT WH 5/16x2 BLK
(3 PLCS)

F3

●INSTALL T-NUTS PRIOR TO ASSEMBLY

T-NUT 5/16 BLK
(4 PLCS)

WASHER LOCK EXT 8x19 BLK
(4 PLCS)

BOLT WH 5/16x2-3/4 BLK
(1 PLCS)

SCREW PFH 8x1-1/2 BLK
(1 PLCS)

WP10

F3

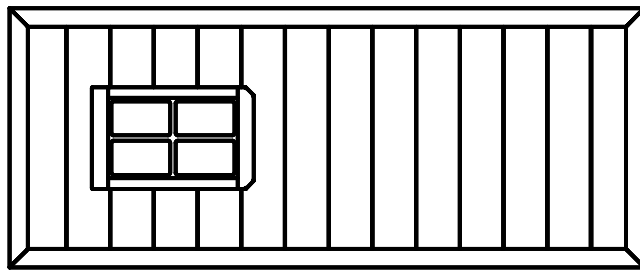

(1) WP9 - LOWER WALL PANEL - W2A02090
1"x16 7/8"x46 1/2" (24x476x1181)

STEP 30

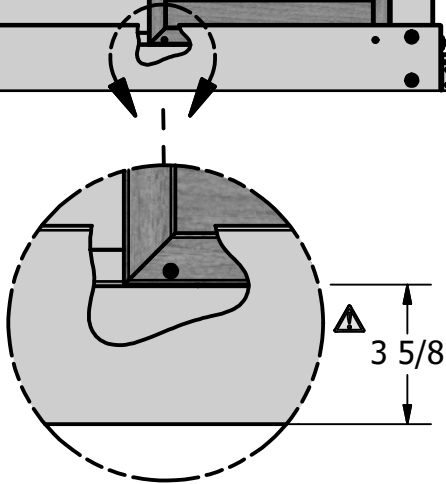
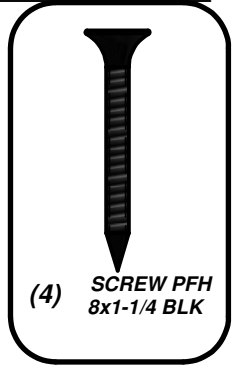
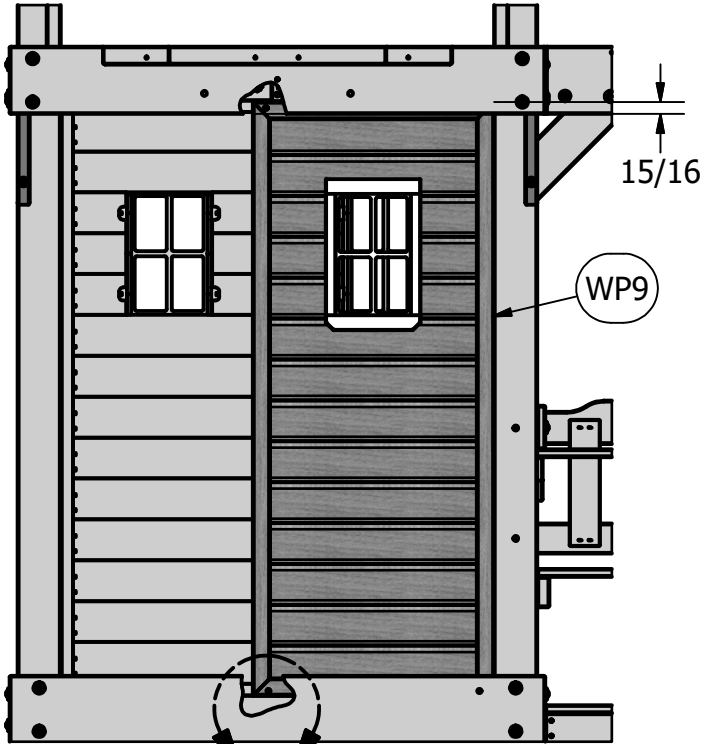

SCREW PFH 8x1-1/4 BLK
(4 PLCS)

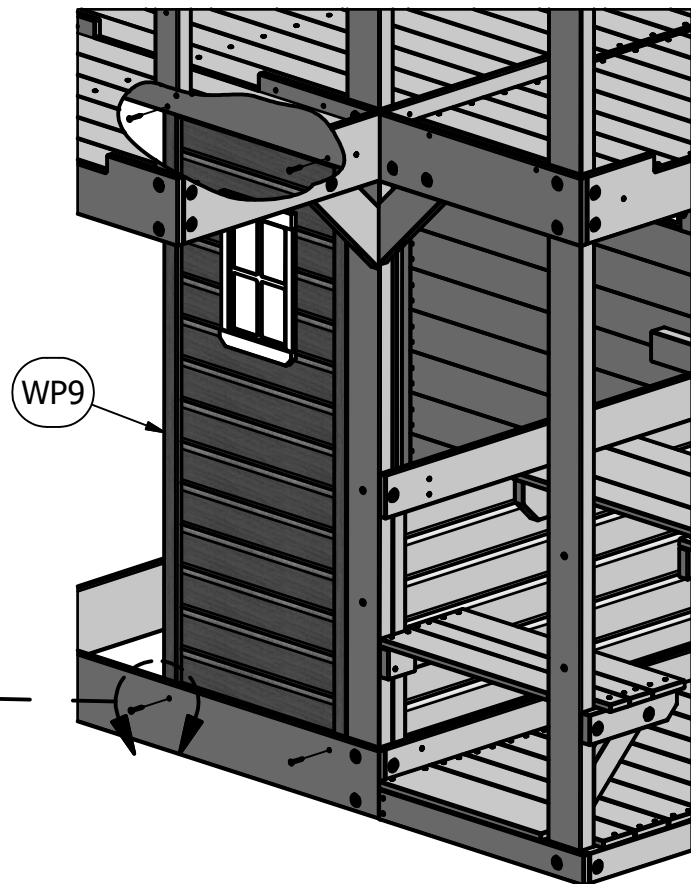
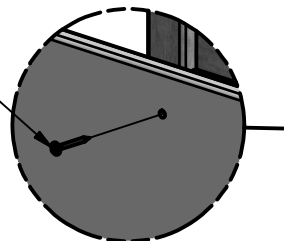



(1) **F4 - SUPPORT BLOCK - W4L11160**
 1 3/8"x2 3/8"x9 1/4" (36x60x234)

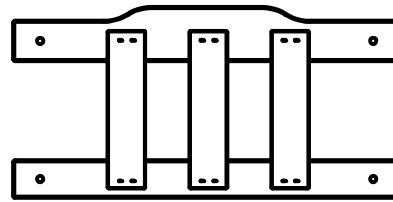

(1) **WP10 - BENCH BACK ASSEMBLY - W2A02081**
 1 1/8"x11 7/8"x17 5/8" (27x303x615)

STEP 31

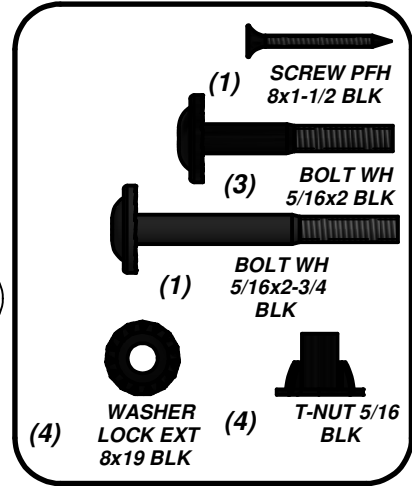
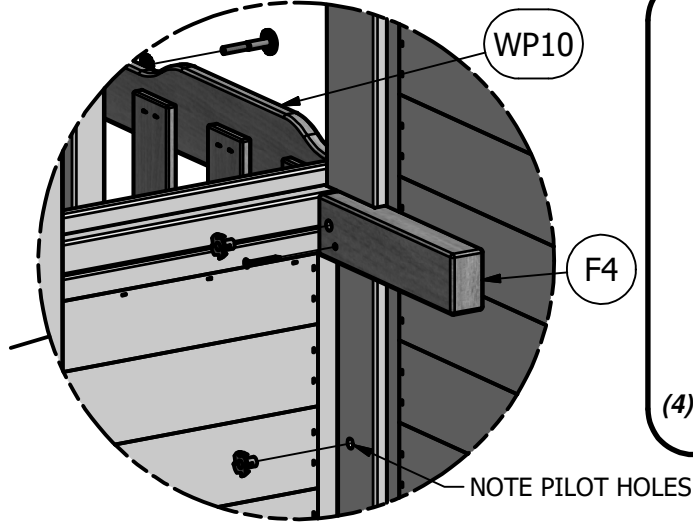
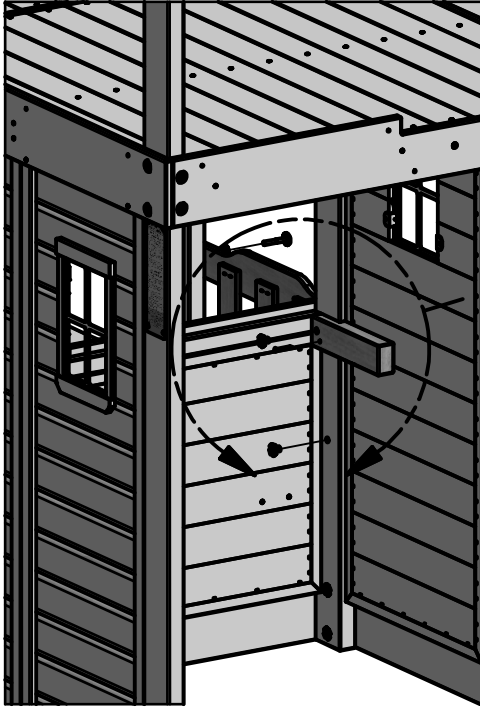

•INSTALL T-NUTS PRIOR TO ASSEMBLY

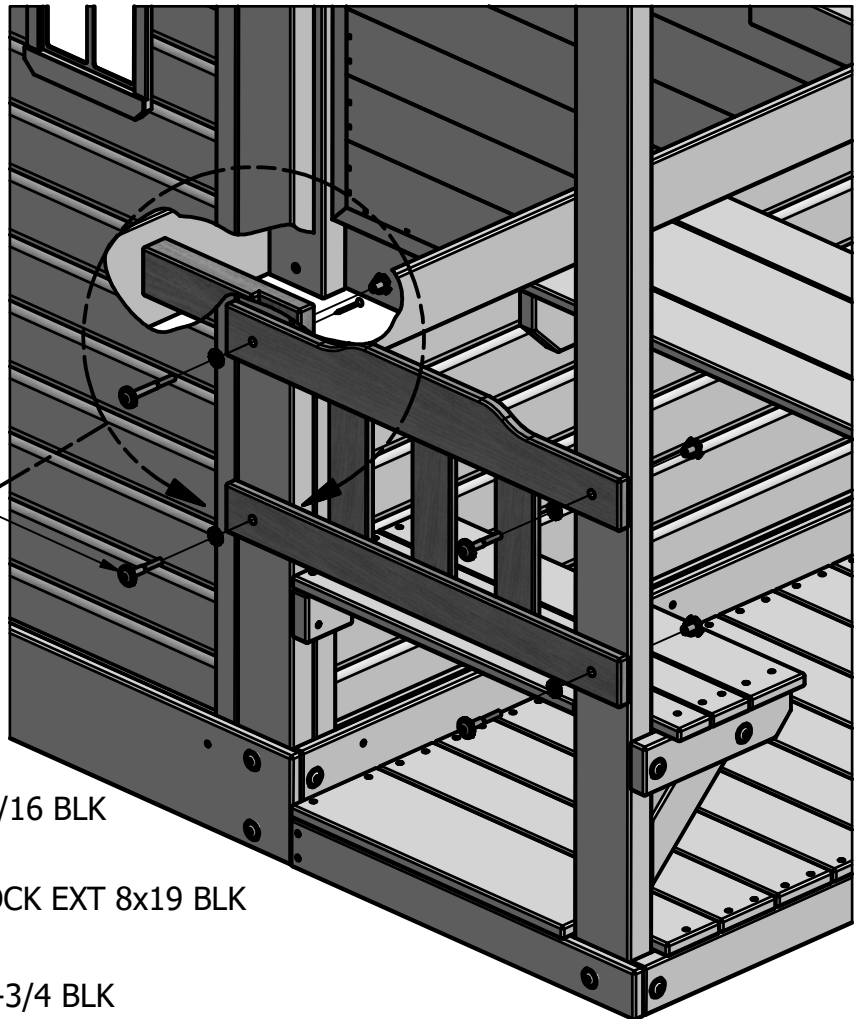

BOLT WH 5/16x2 BLK (3 PLCS)

SCREW PFH 8x1-1/2 BLK (1 PLCS)

F4

WP10

T-NUT 5/16 BLK (4 PLCS)

WASHER LOCK EXT 8x19 BLK (4 PLCS)

BOLT WH 5/16x2-3/4 BLK (1 PLCS)



(1) **M6 - COUNTER TOP - W4L07605**
5/8"x3 3/8"x37 5/8" (16x86x957)



(2) **M7 - COUNTER TOP - W4L07606**
5/8"x3 3/8"x38 5/8" (16x86x981)

STEP 32

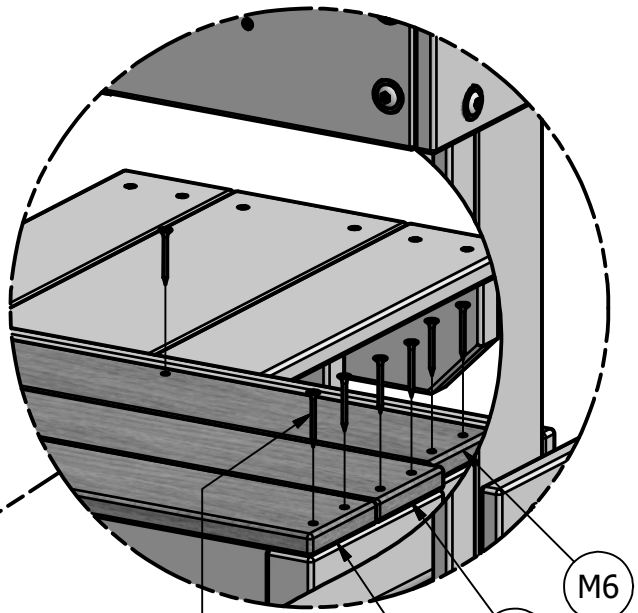
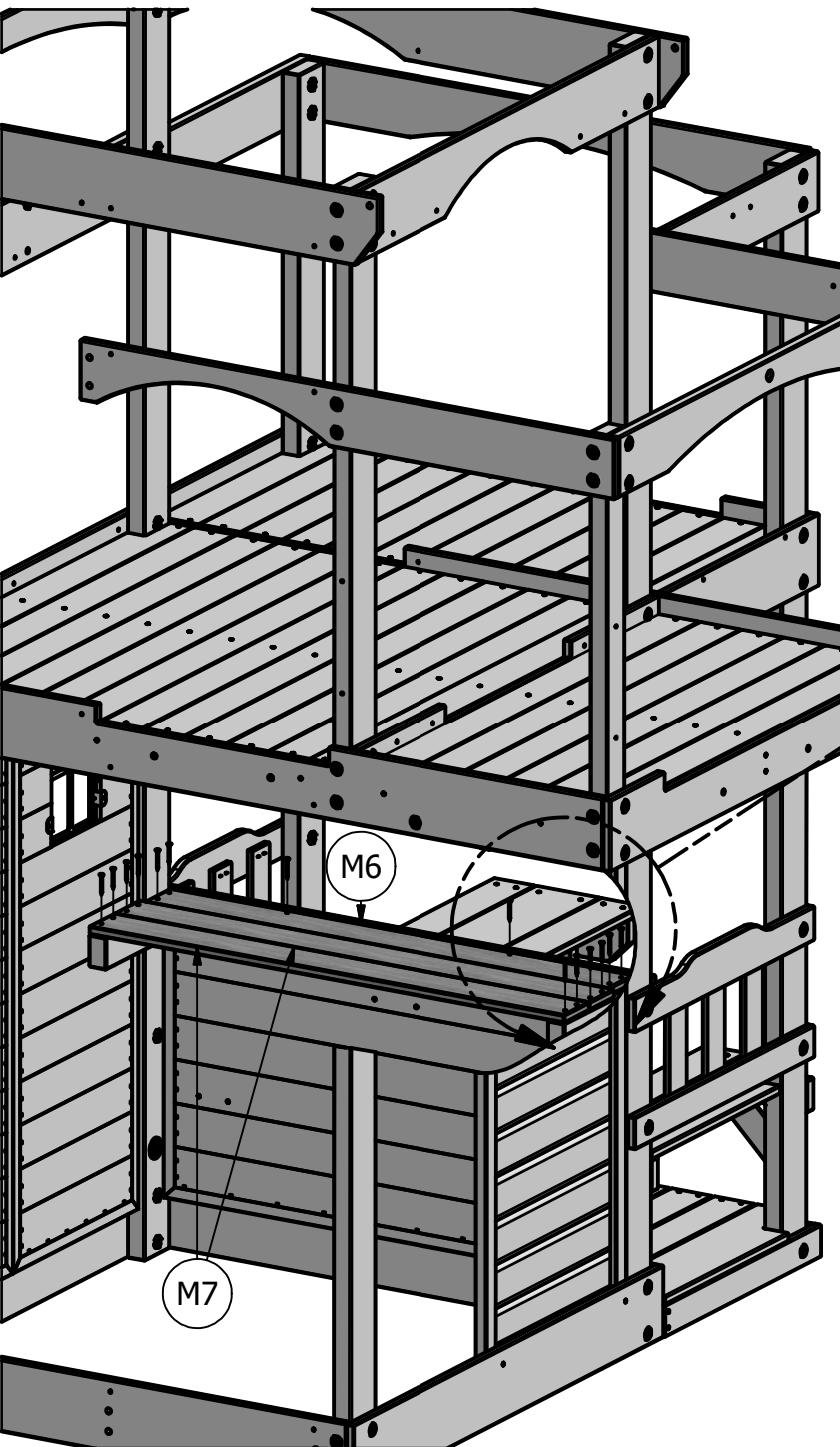
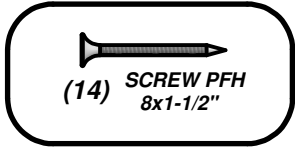

SCREW PFH 8x1-1/2"
(14 PLCS)

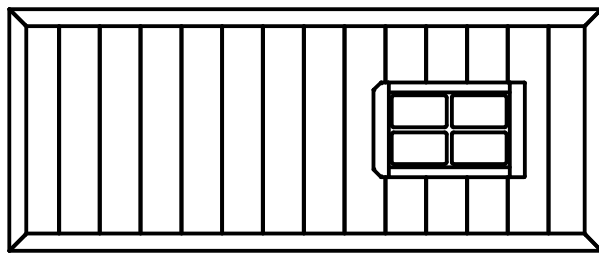

(1) WP9 - LOWER WALL PANEL - W2A02090
1"x18 7/8"x46 1/4" (24x479x1176)

STEP 33

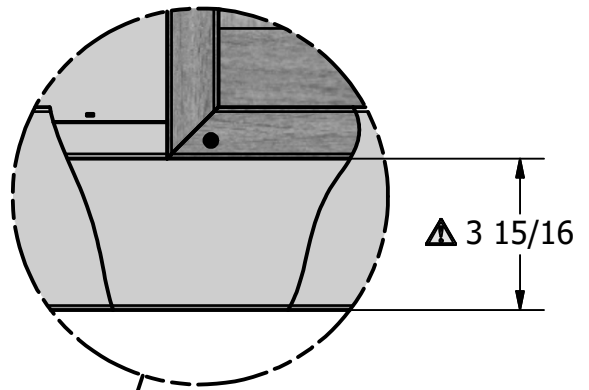
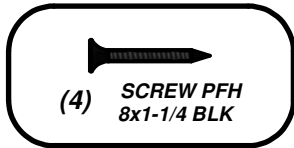
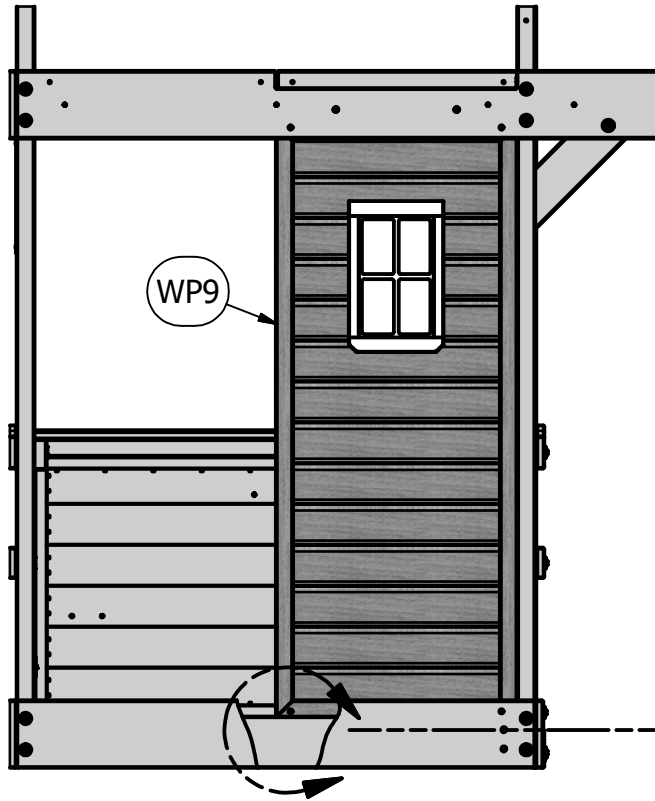

3 15/16

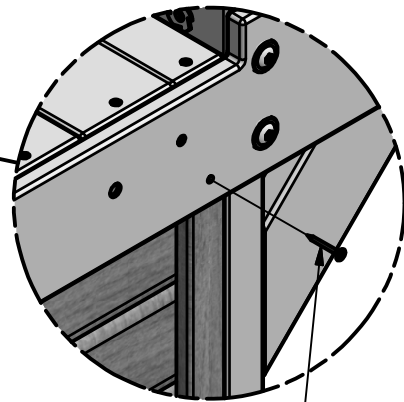
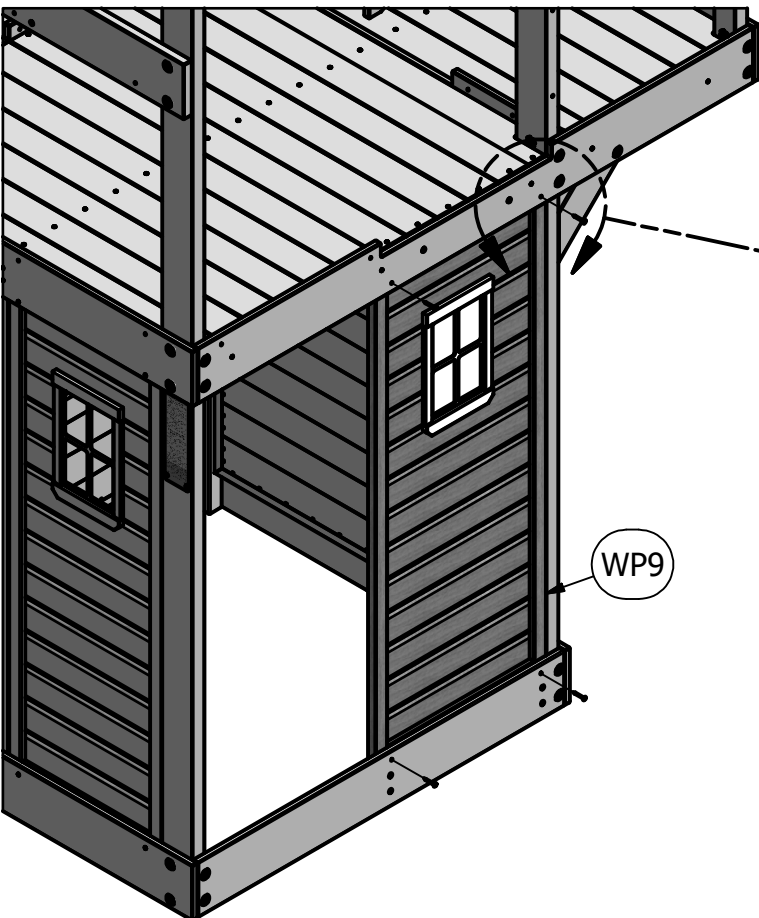

SCREW PFH 8x1-1/4 BLK
(4 PLCS)

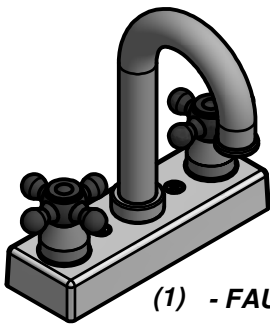

(1) - FAUCET KIT - A6P00024

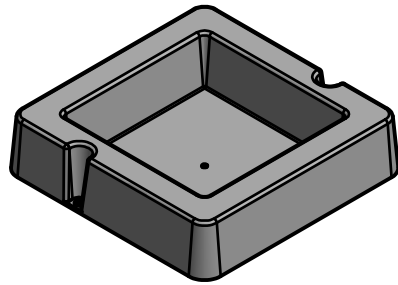

(1) - SURFACE MOUNT BASIN - A6P00032

STEP 34

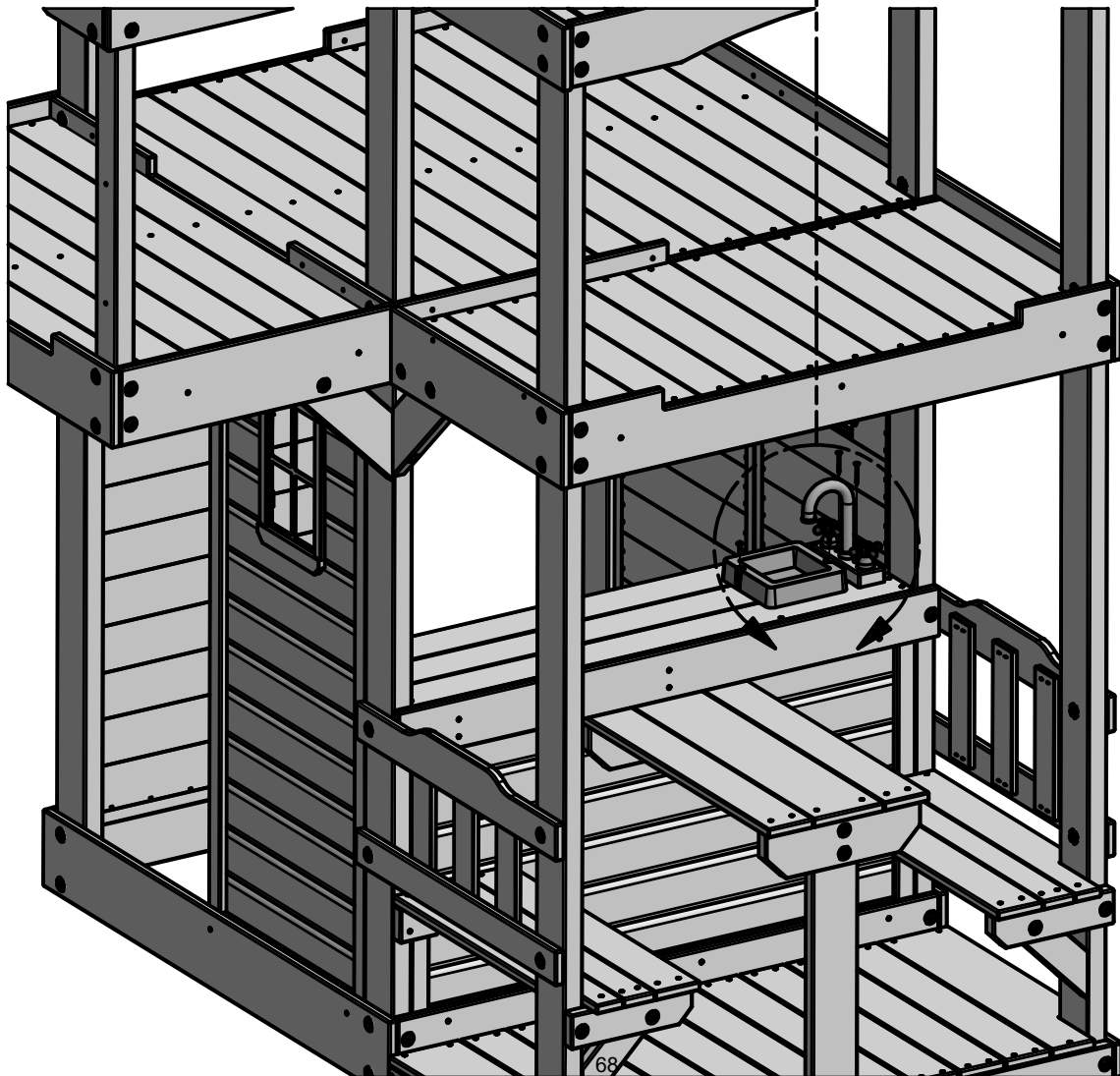
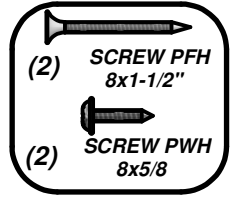
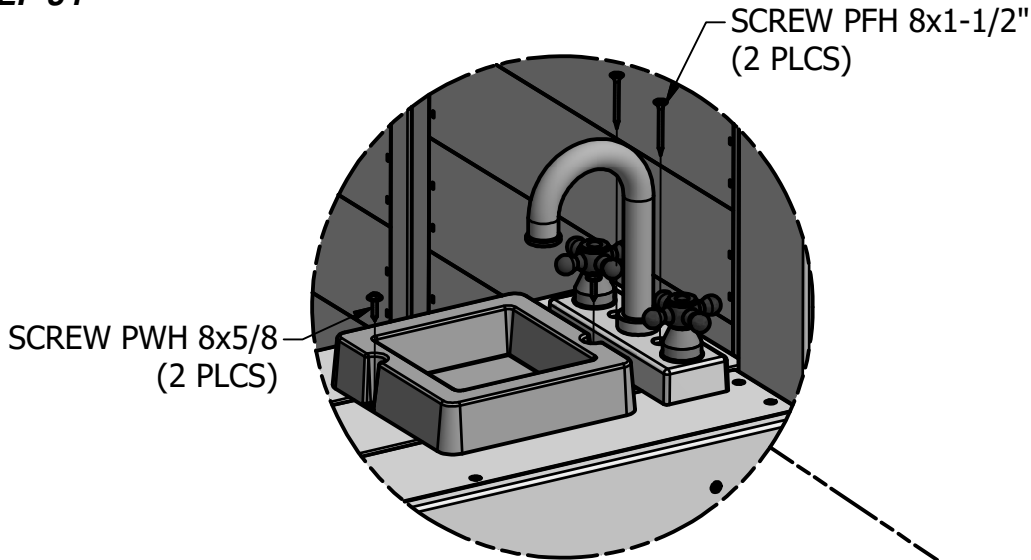

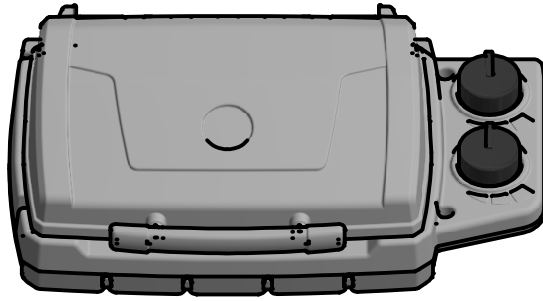

(1) GRILL - A6P00282

STEP 35

HANDLE ASSEMBLY



GRILL LOCATION

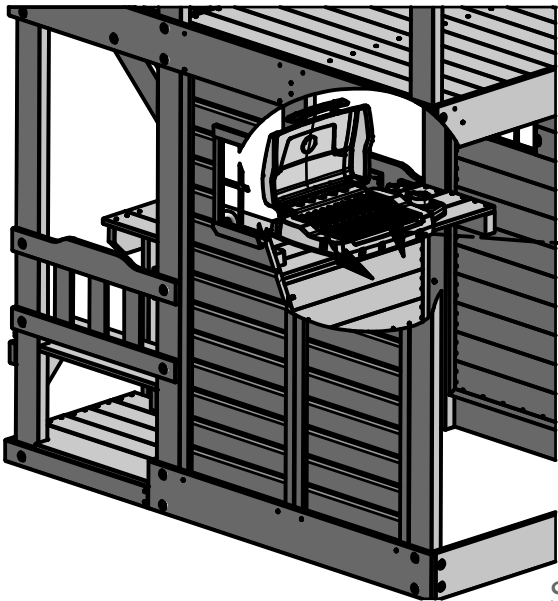
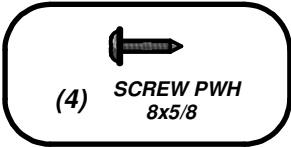
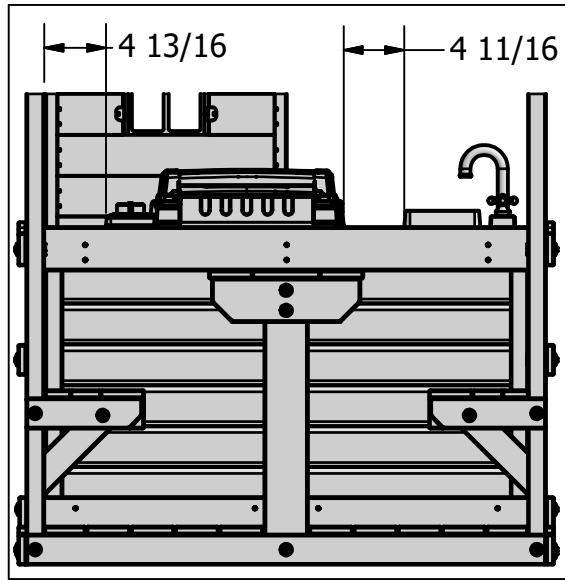

SCREW PWH 8x5/8
(4 PLCS)

NOTE: GRILL LIP SHOULD BE TOUCHING COUNTER TOP EDGE.

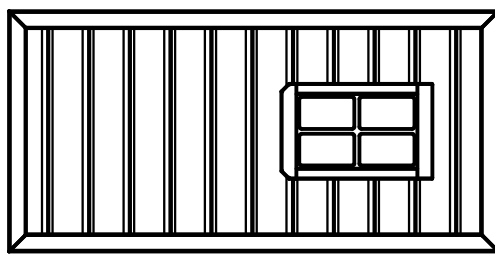

(1) WP7 - TOP FRONT WALL PANEL - W2A02088
1"x16 7/8"x38 1/4" (24x476x971)

STEP 36

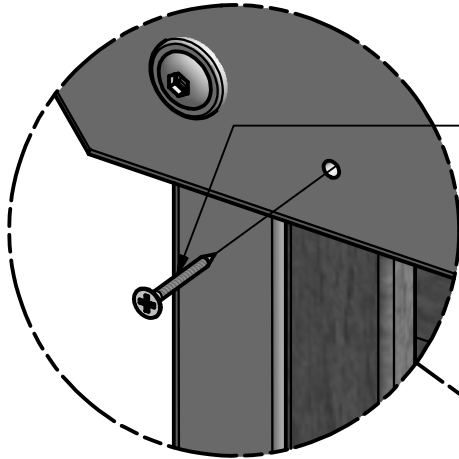
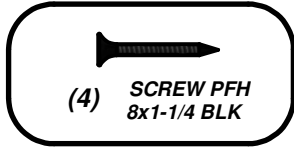

SCREW PFH 8x1-1/4 BLK
(4 PLCS)

WP7

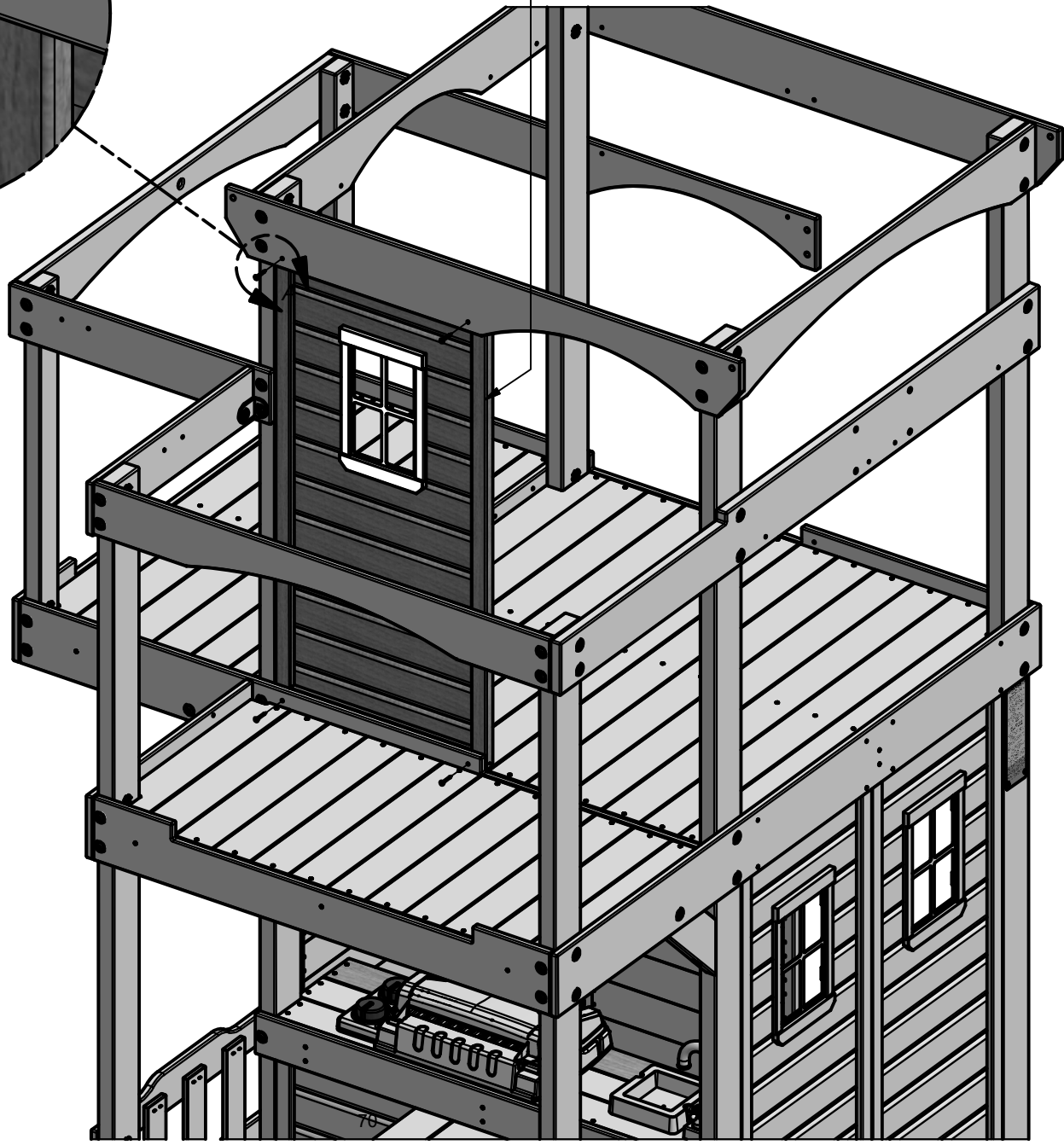

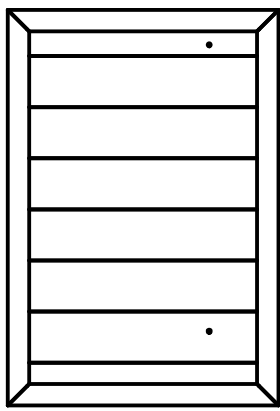

(1) WP4 - TOP RIGHT FRONT WALL PANEL - W2A02498
1"x16 7/8"x24 5/8" (24x430x627)

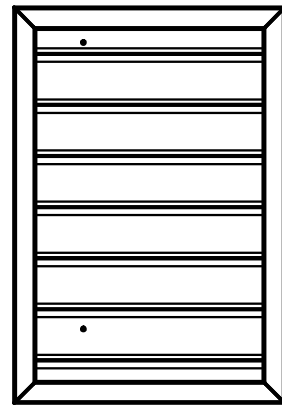

(1) WP3 - TOP RIGHT FRONT WALL PANEL - W2A02497
1"x16 7/8"x24 5/8" (24x430x627)

STEP 37

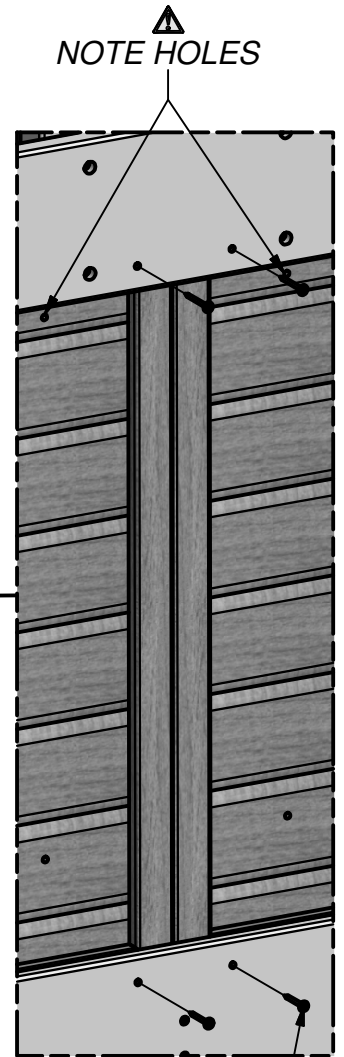
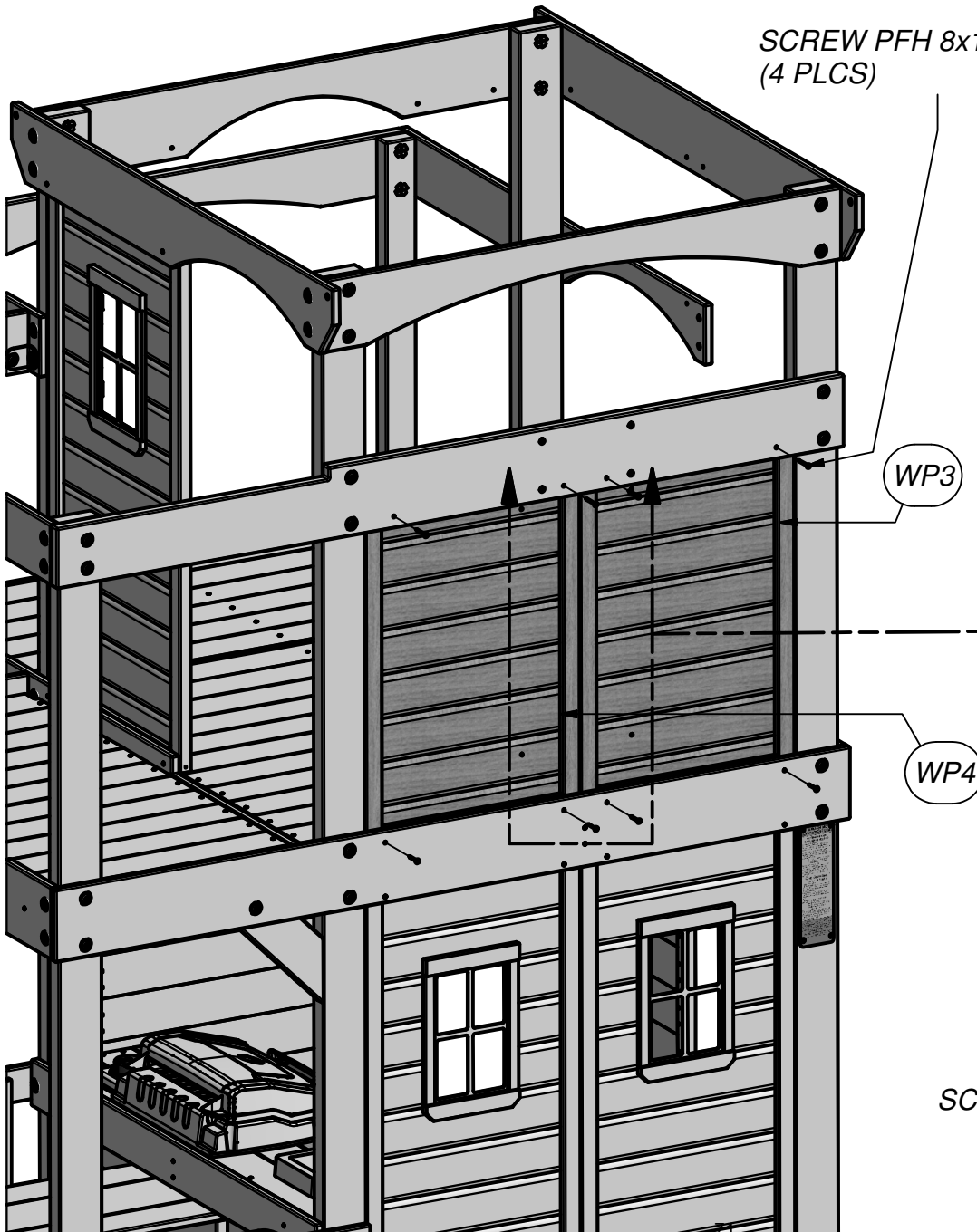
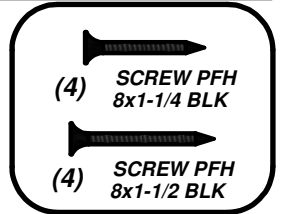

SCREW PFH 8x1-1/4 BLK
(4 PLCS)

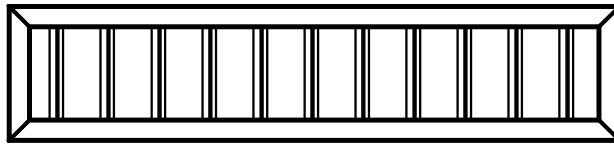

(2) WP8 - TOP LEFT WALL PANEL - W2A02089
1"x11 3/4"x38 1/4" (24x214x971)

STEP 38

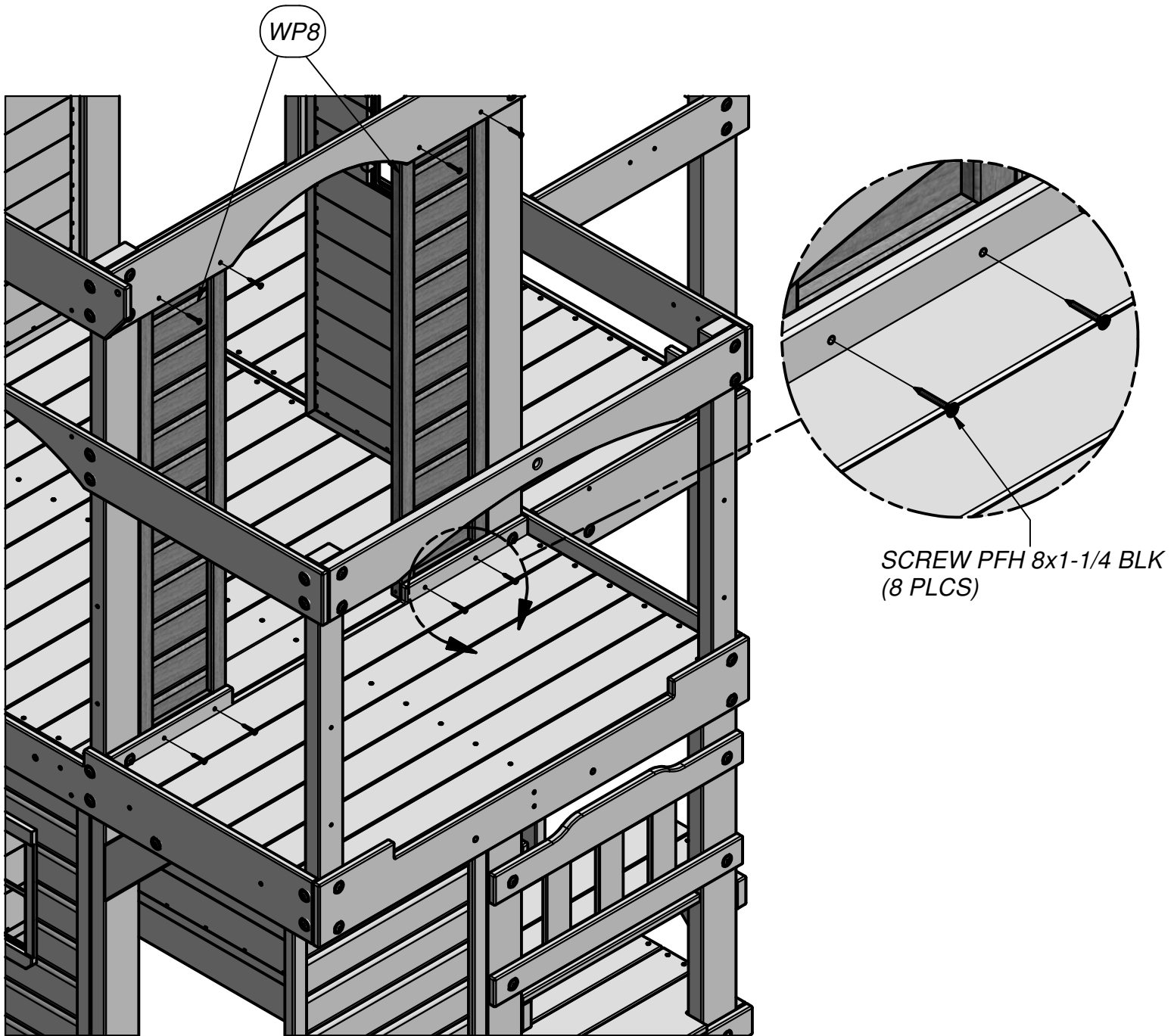
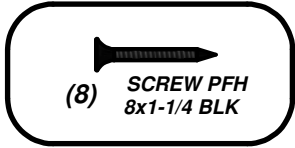

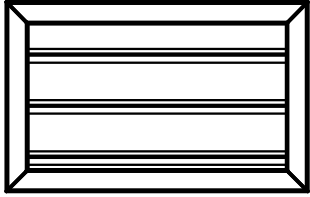

(1) WP6 - TOP REAR WALL PANEL - W2A02087
1"x18 7/8"x11 3/4" (24x479x300)

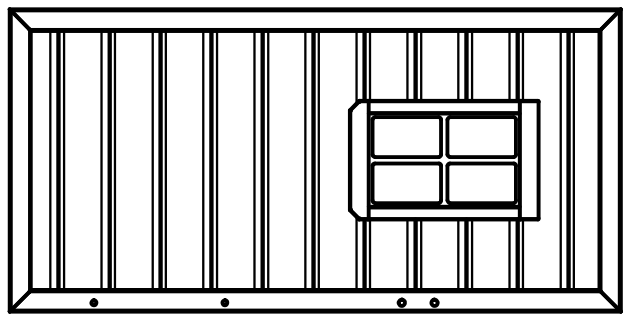

(1) WP5 - TOP LEFT REAR WALL PANEL - W2A02086
1"x16 7/8"x46 1/2" (24x430x971)

STEP 39

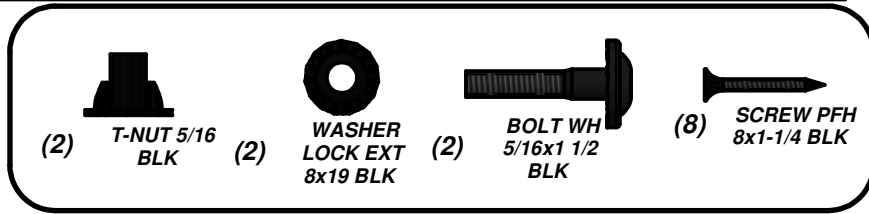

WASHER LOCK EXT 8x19 BLK
(2 PLCS)

T-NUT 5/16 BLK
(2 PLCS)

BOLT WH 5/16x1 1/2 BLK
(2 PLCS)

SCREW PFH 8x1-1/4 BLK
(8 PLCS)

WP6

WP5

NOTE HOLES



(8) N2 - PICKET - W4L07612
5/8"x2 3/8"x24 3/4" (16x60x628)

STEP 40

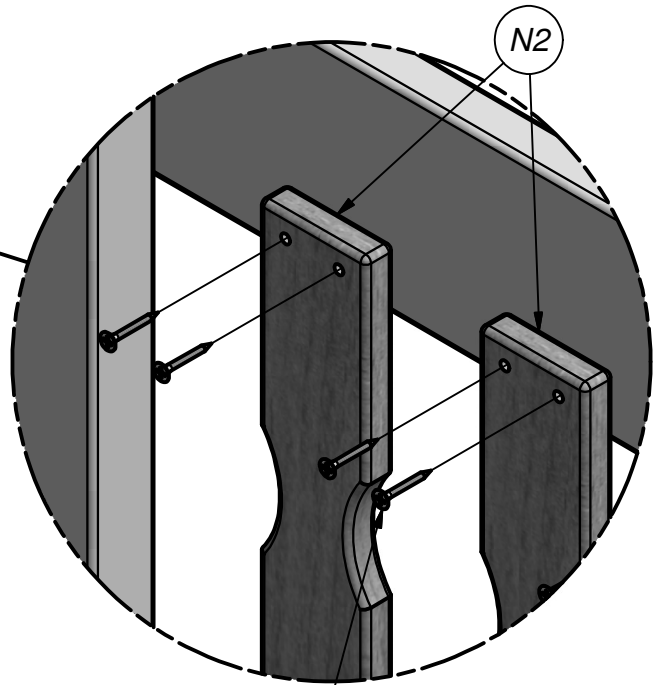
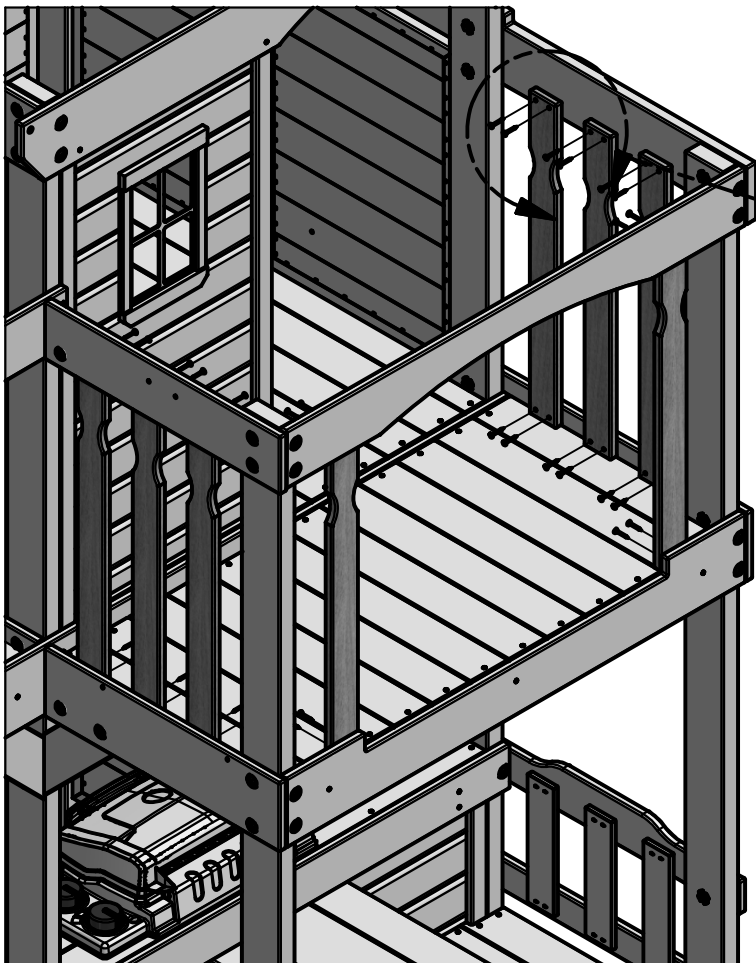
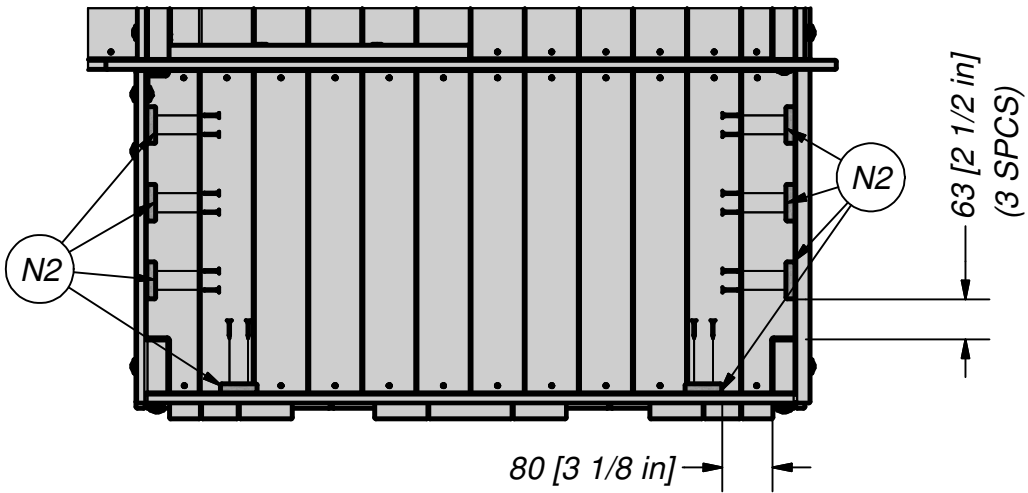
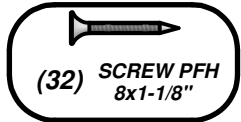

SCREW PFH 8x1-1/8"
(32 PLCS)

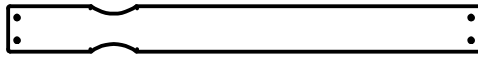

(10) N2 - PICKET - W4L07612
5/8"x2 3/8"x24 3/4" (16x60x628)

STEP 41

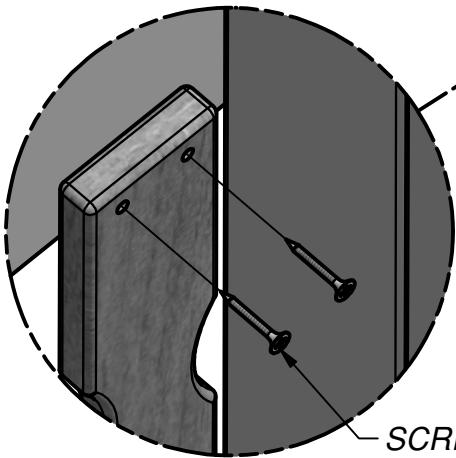
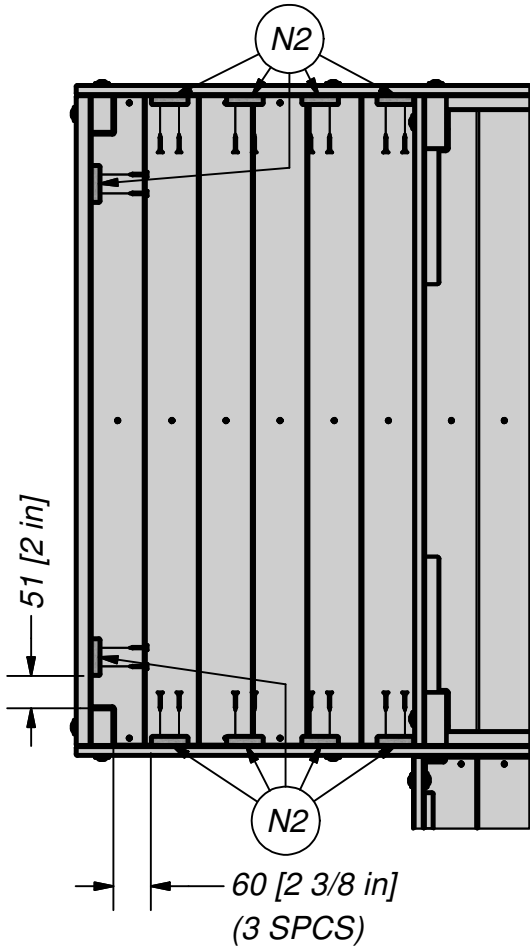
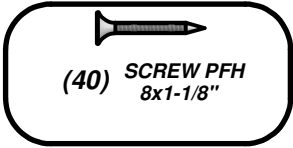

SCREW PFH 8x1-1/8"
(40 PLCS)

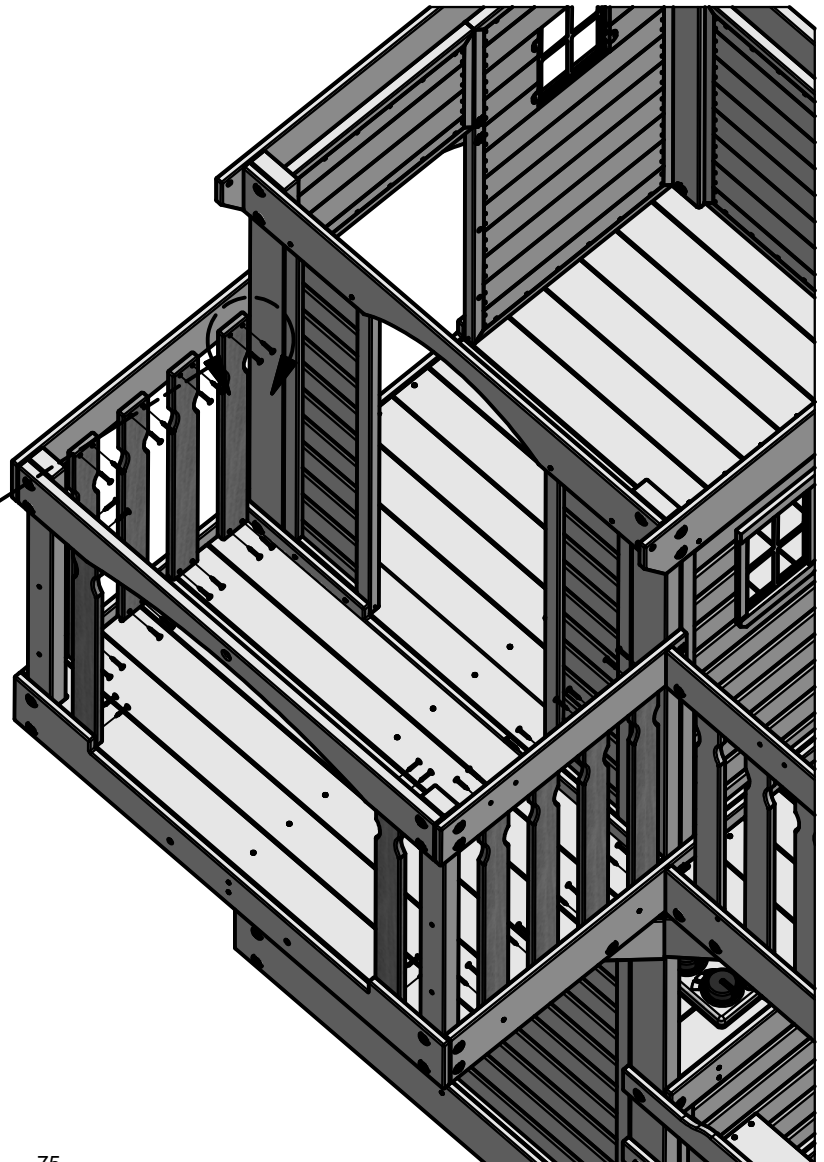

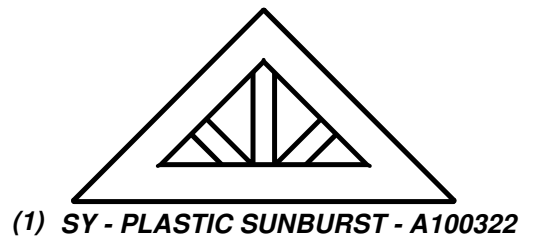
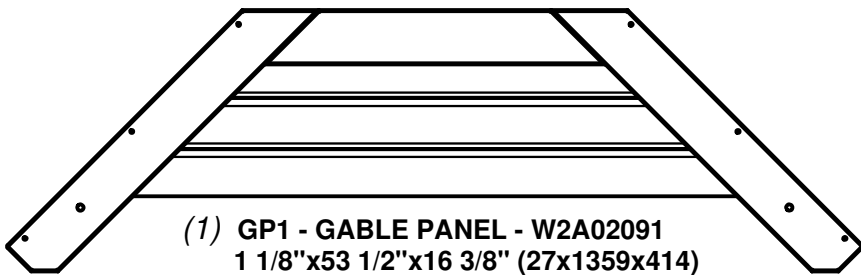

STEP 42

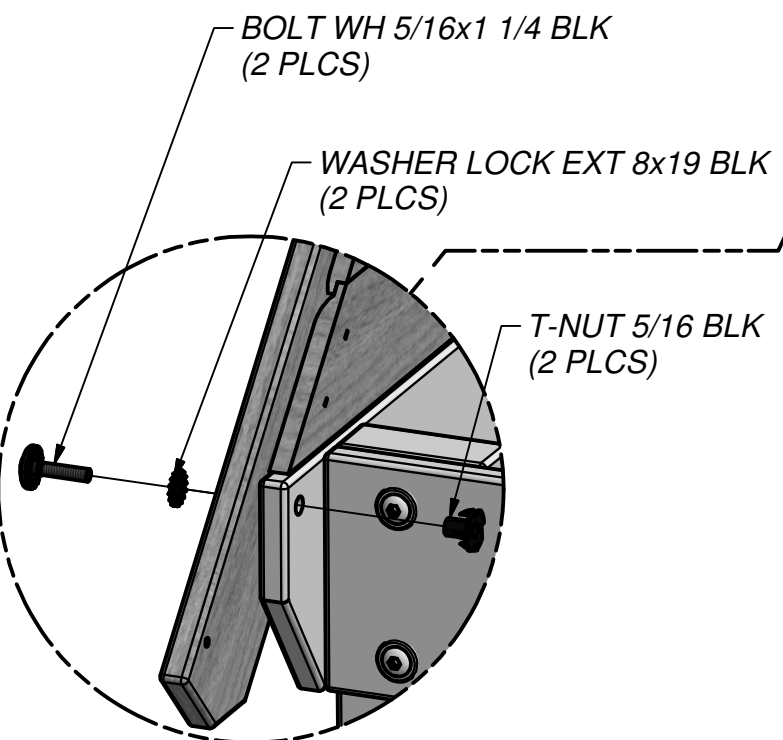
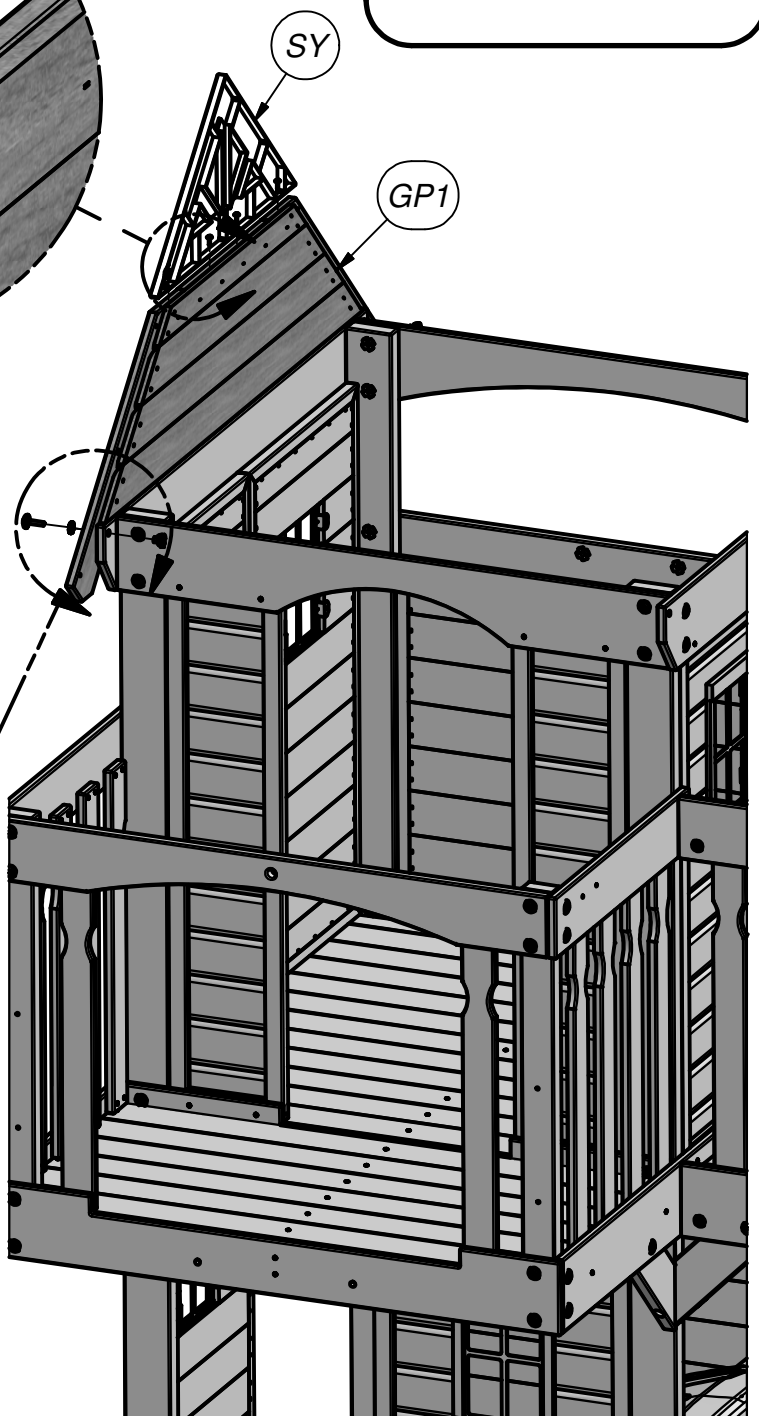
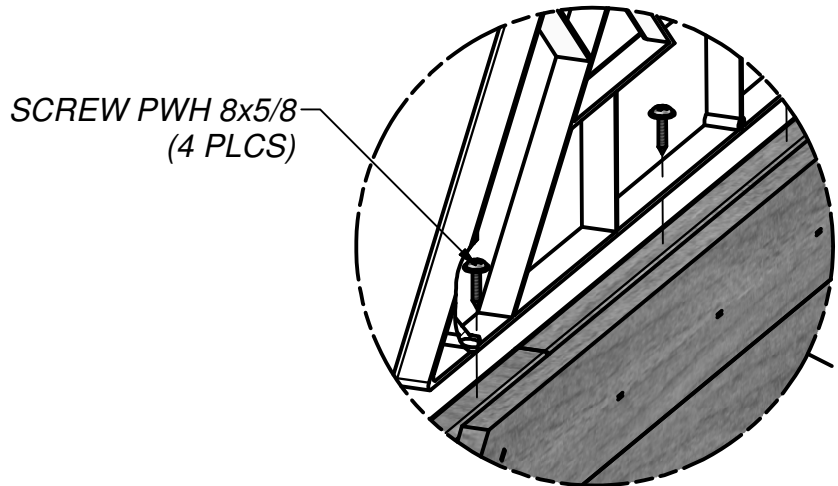
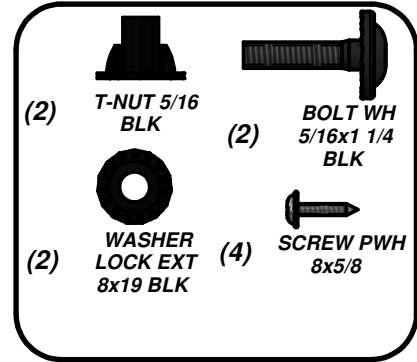

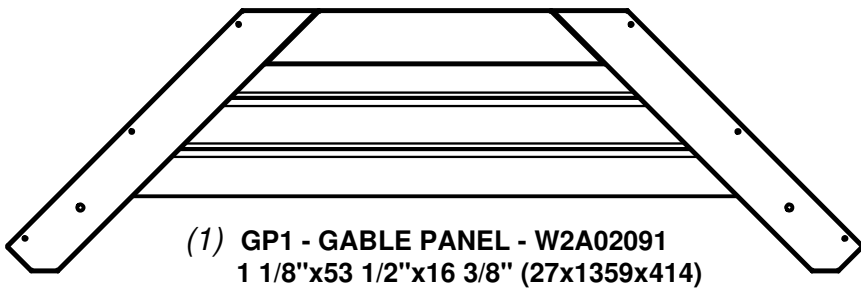

(1) GP1 - GABLE PANEL - W2A02091
1 1/8"x53 1/2"x16 3/8" (27x1359x414)

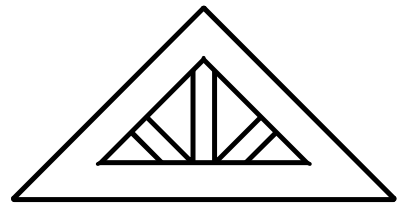

(1) SY - PLASTIC SUNBURST - A100322

STEP 43

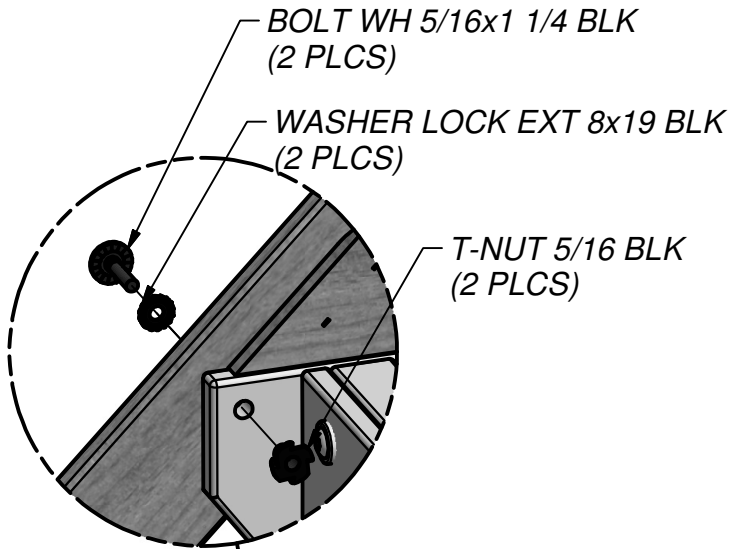
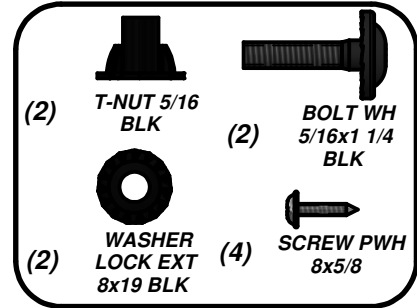

SCREW PWH 8x5/8
(4 PLCS)

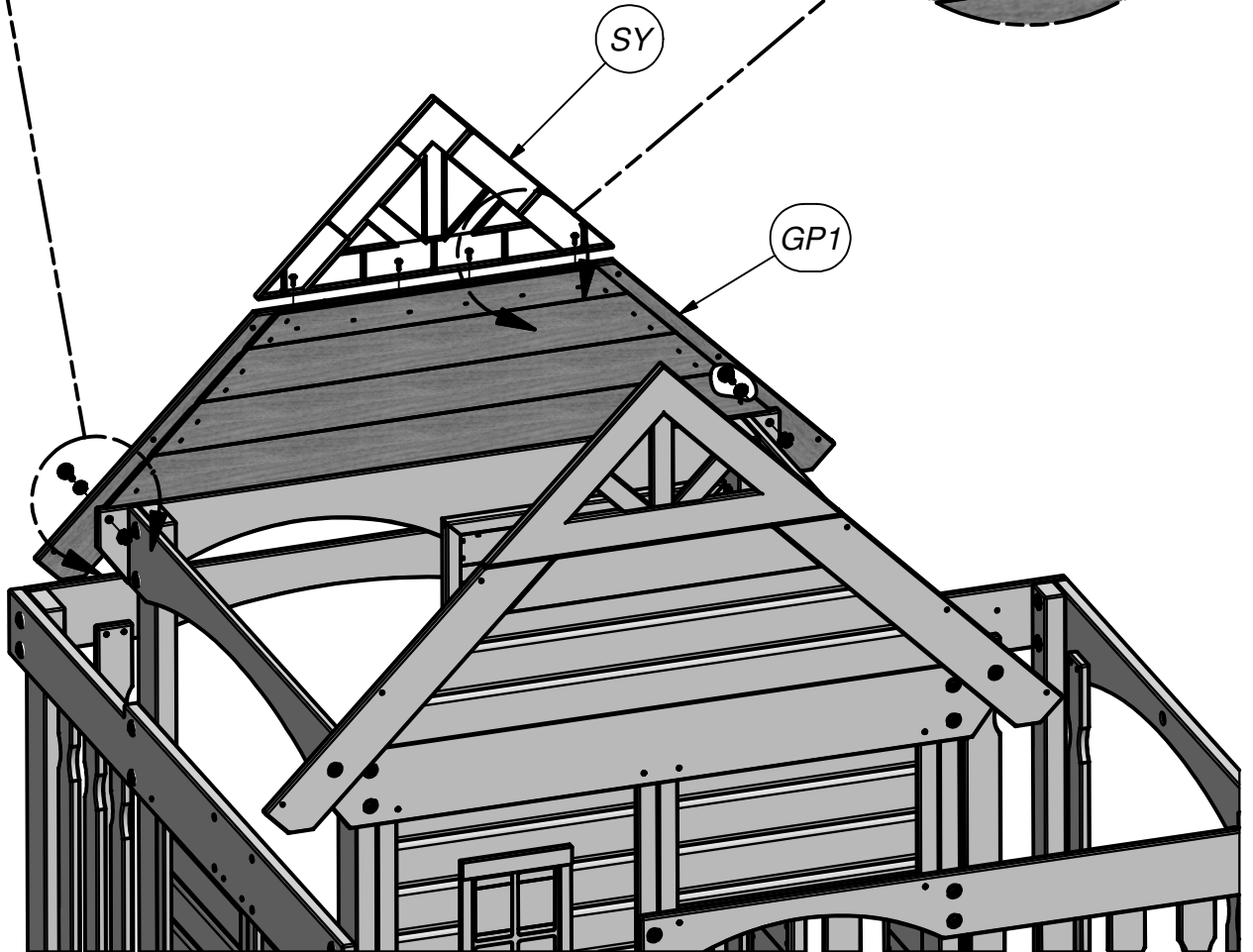
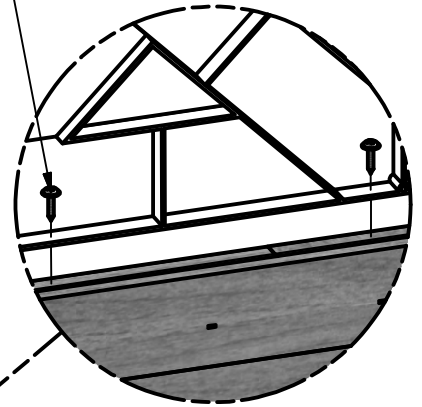

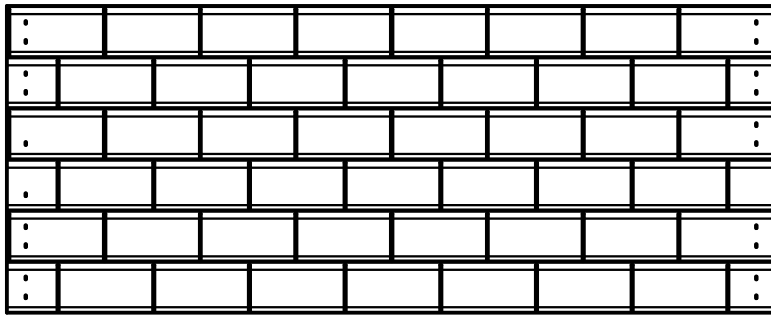

(2) RP2 - TOP ROOF PANEL - W2A02495
 1 3/8"x48"x19 1/8" (35x1220x486)

STEP 44

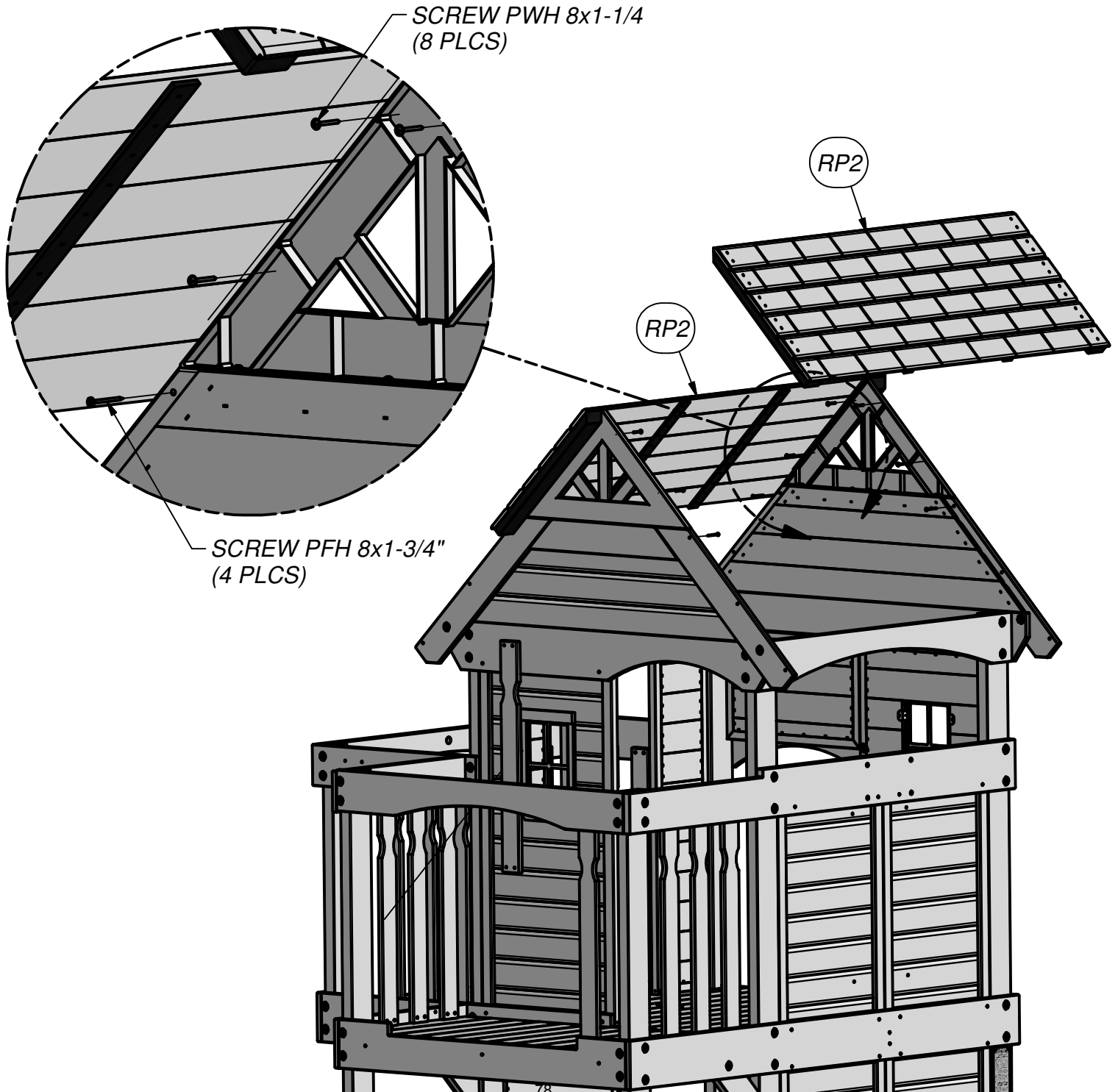
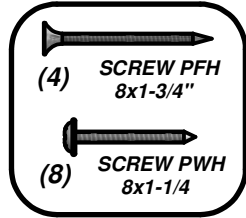

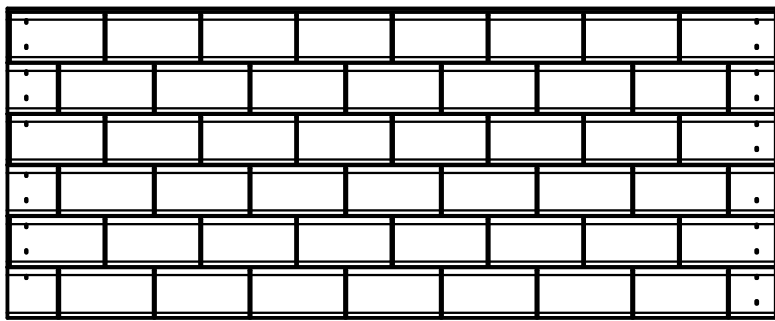

(2) RP1 - BOTTOM ROOF PANEL - W2A02494
1 3/8"x48"x19 3/8" (35x1220x491)

STEP 45

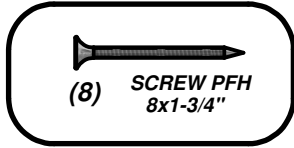

SCREW PFH 8x1-3/4"
(8 PLCS)

NOTE HOLES

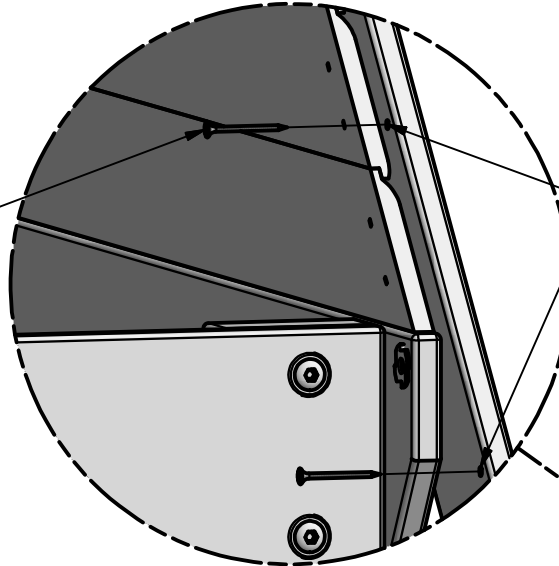

RP1

RP1

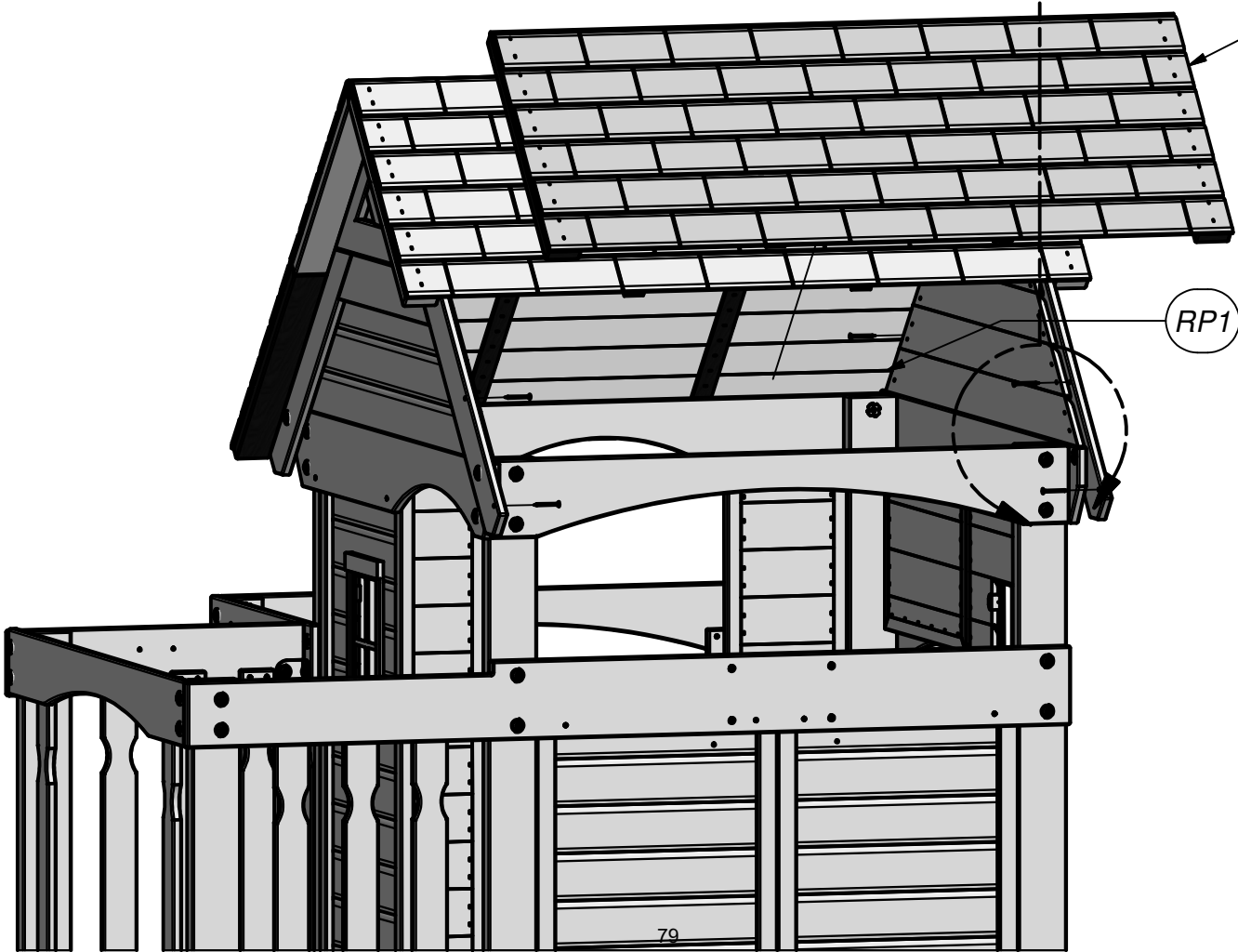



(1) E10 - MOUNTING BLOCK - W4L11155
1 3/8"x3"x4 3/4" (36x76x120)

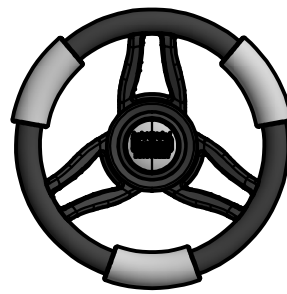

(1) LP - STEERING WHEEL - A100105

STEP 46

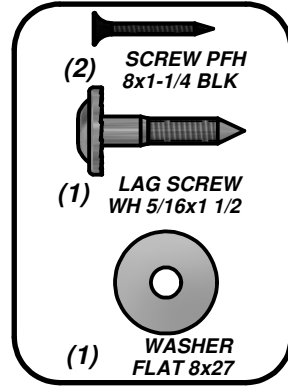
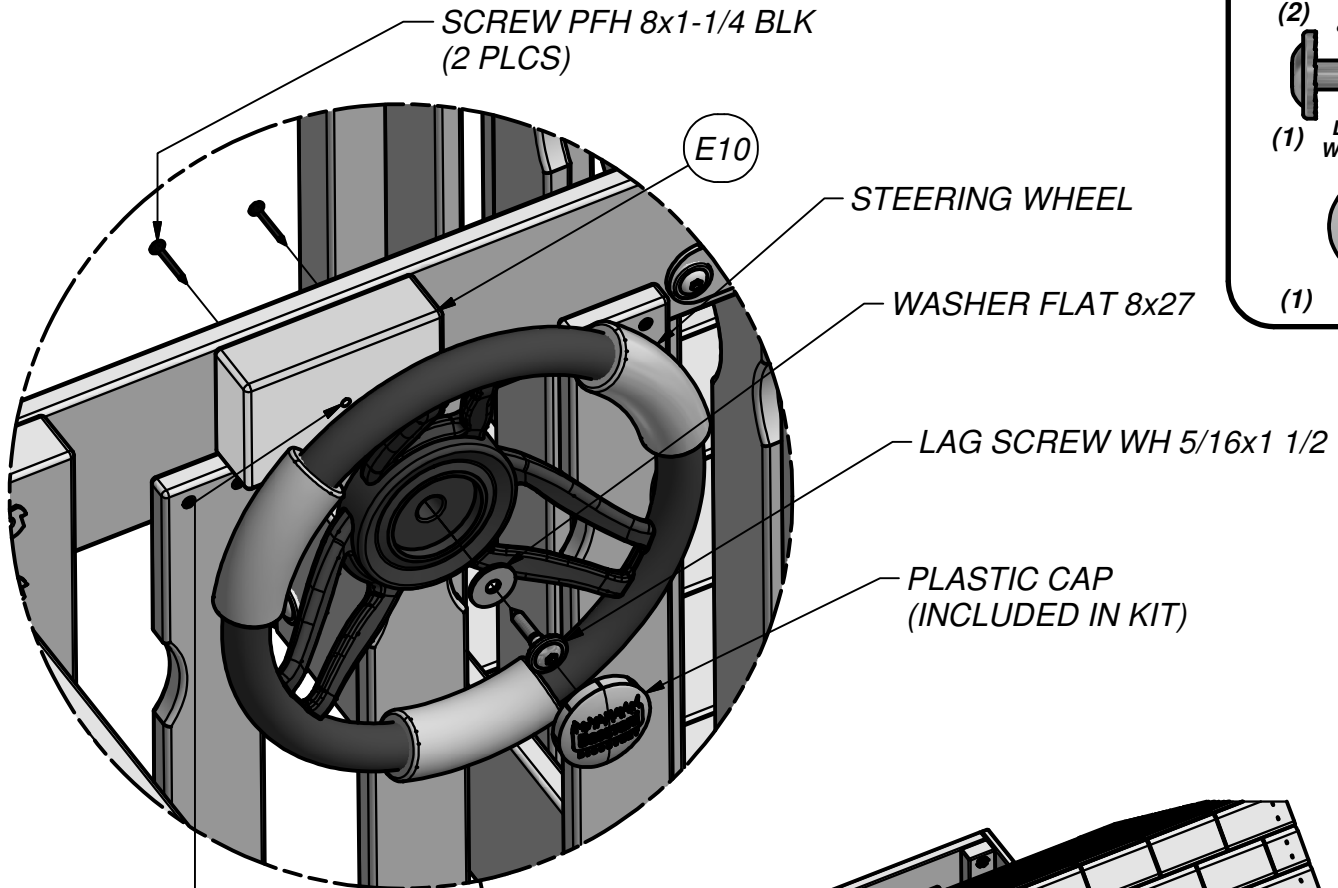

NOTE HOLE LOCATION
FOR PROPER ORIENTATION.

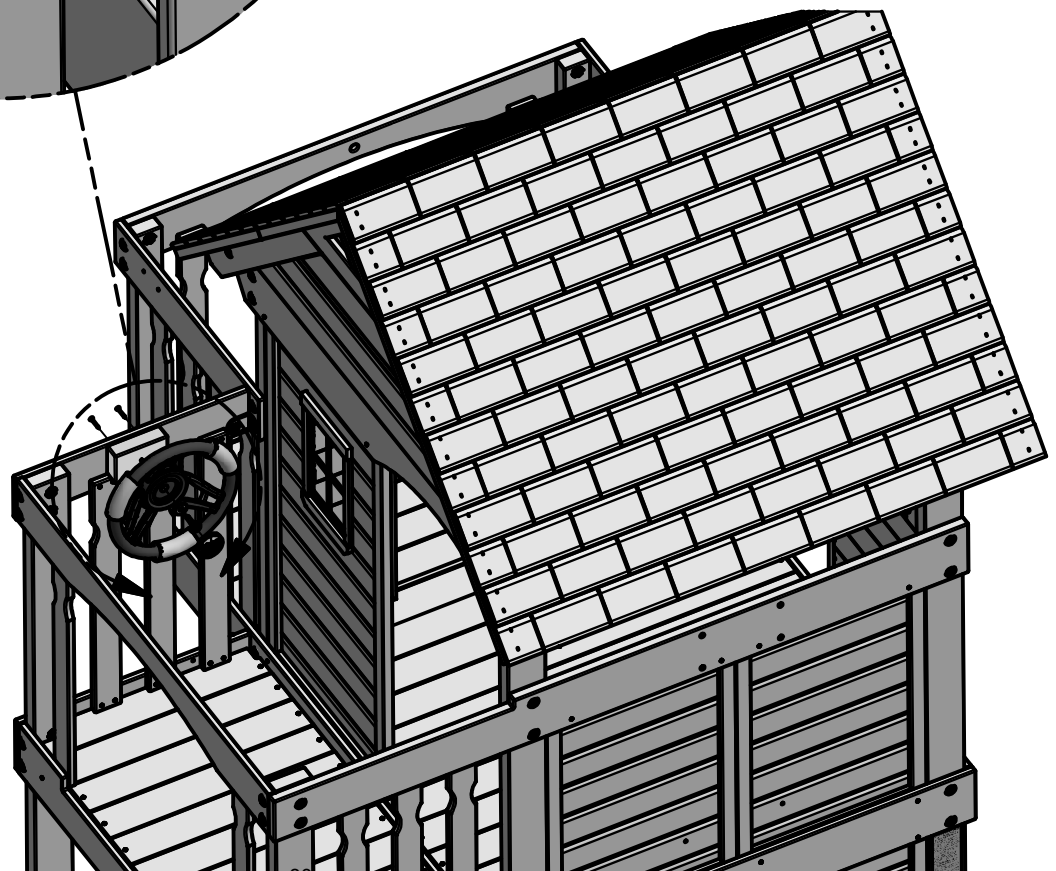

THIS HOLE FACES THE
RAIL IN THIS STEP.

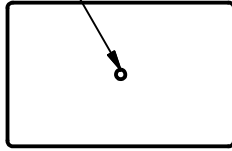

- (1) E10 - MOUNTING BLOCK - W4L11155
1 3/8"x3"x4 3/4" (36x76x120)

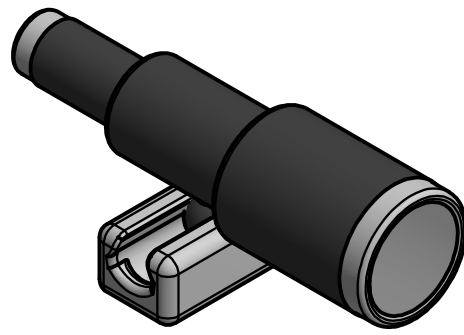

- (1) LN - TELESCOPE - A6P00096

STEP 47

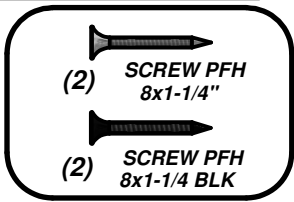

SCREW PFH 8x1-1/4"
(2 PLCS)

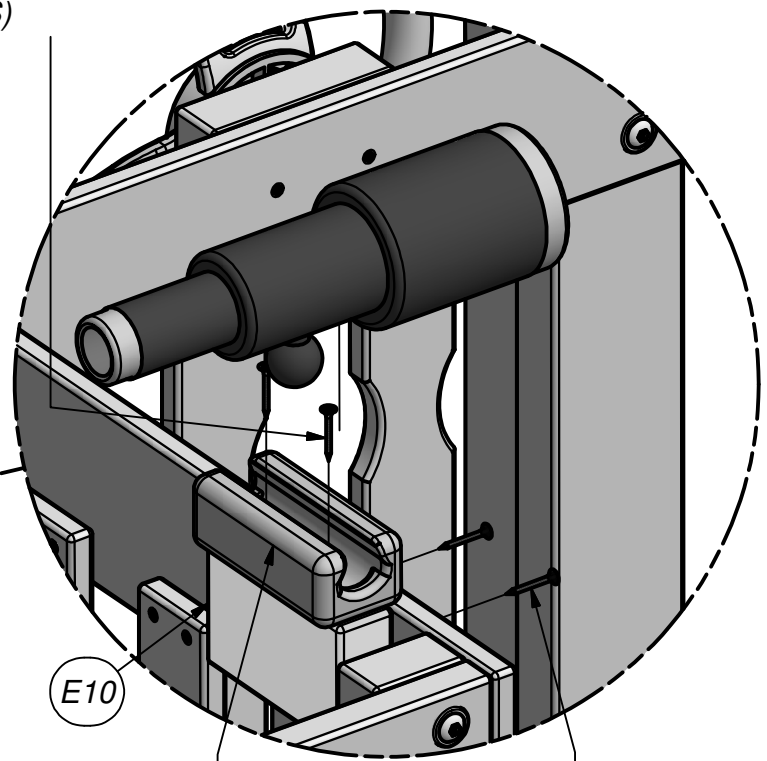
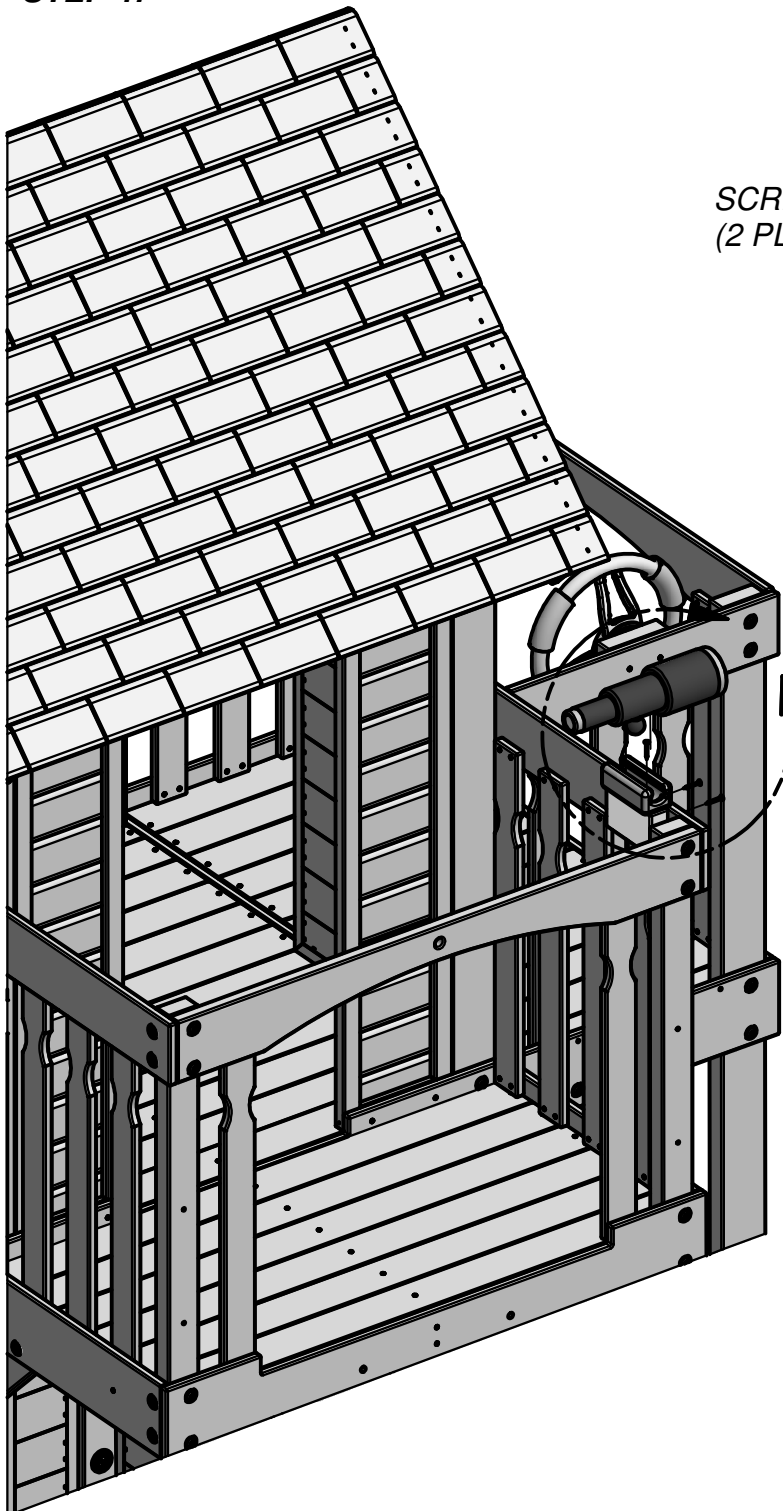

E10

TELESCOPEKIT
SCREW PFH 8x1-1/4 BLK
(2 PLCS)

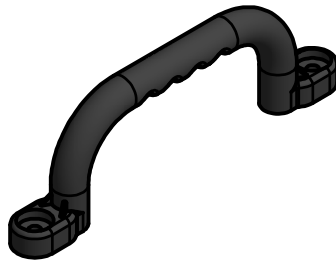

(4) - HAND GRIP GREEN PLASTIC - A100028

STEP 48

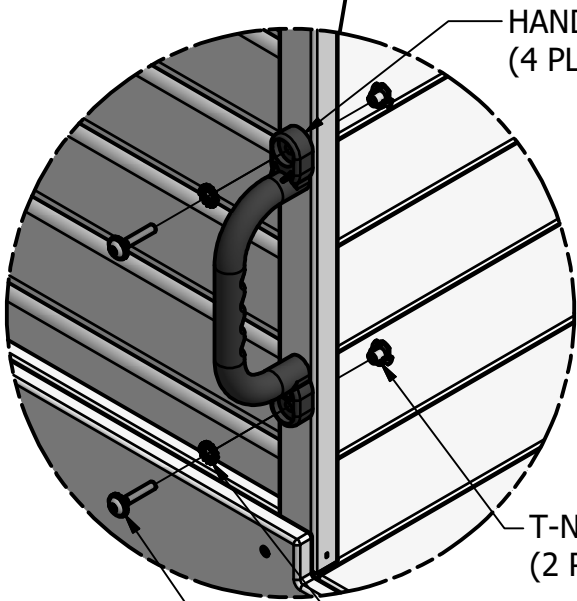
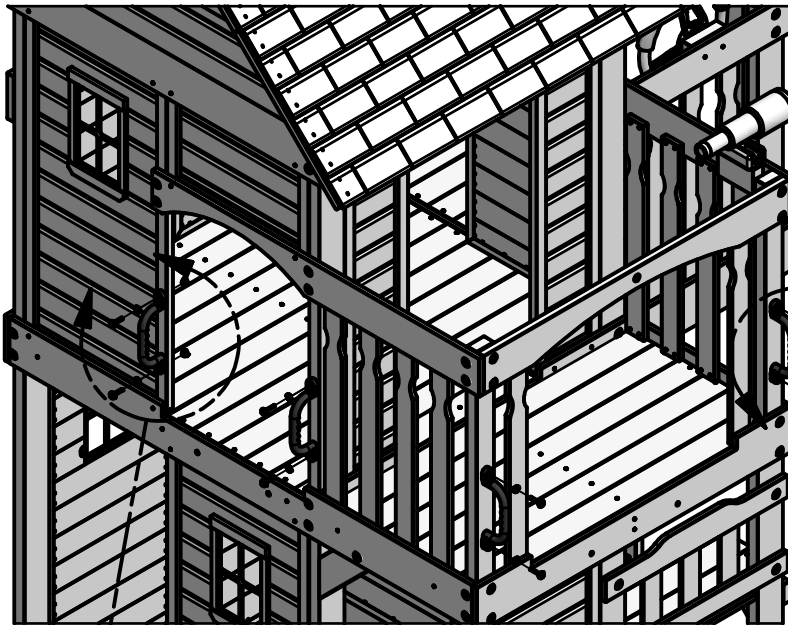
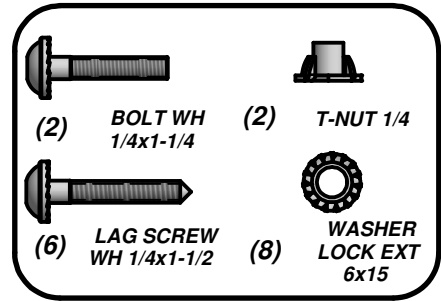

HAND GRIP GREEN PLASTIC
(4 PLCS)

T-NUT 1/4
(2 PLCS)

WASHER LOCK EXT 6x15
(2 PLCS)

BOLT WH 1/4x1-1/4
(2 PLCS)

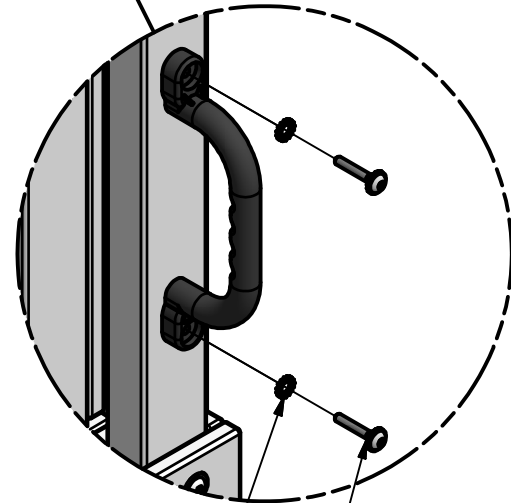

WASHER LOCK EXT 6x15
(6 PLCS)

LAG SCREW WH 1/4x1-1/2
(6 PLCS)

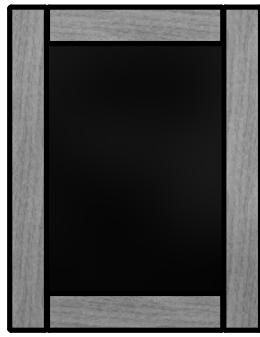

(1) - CHALKBOARD - A4M00906

STEP 49

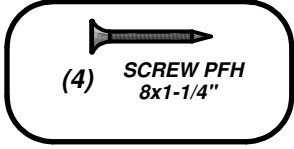

SCREW PFH 8x1-1/4"
(4 PLCS)

NOTE HOLES IN CHALKBOARD

CHALKBOARD

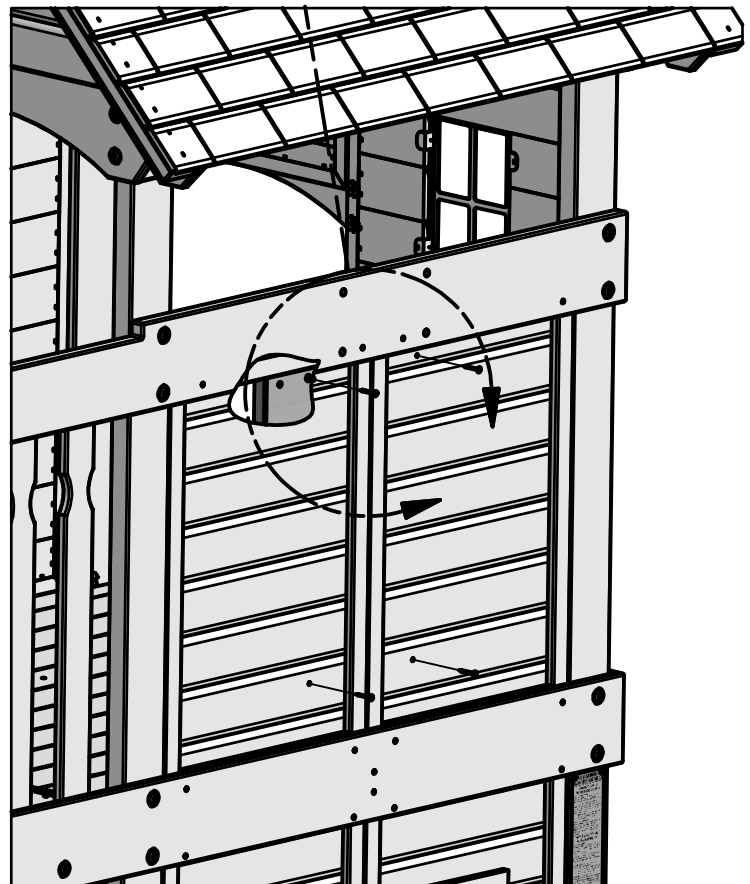
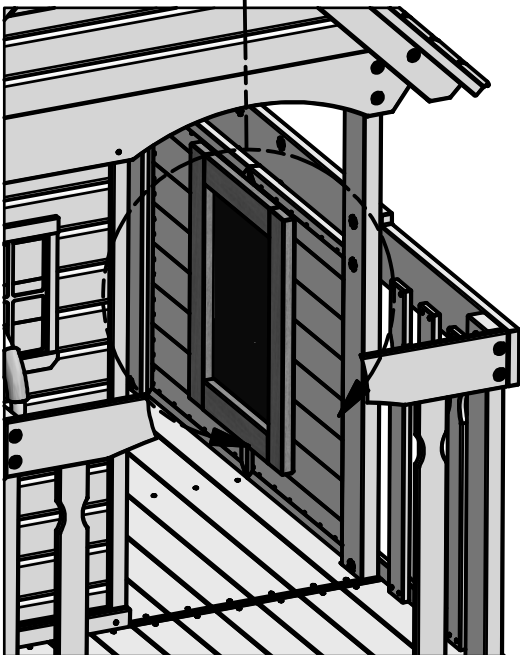
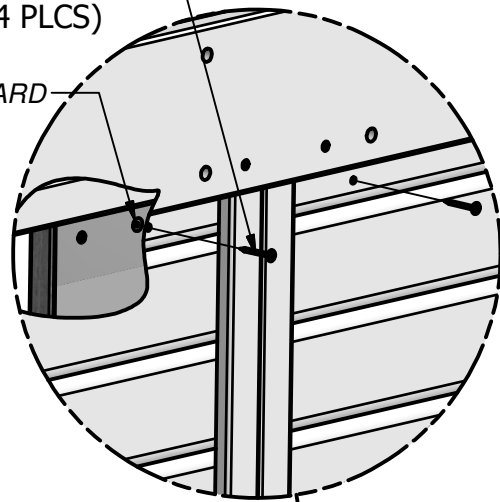
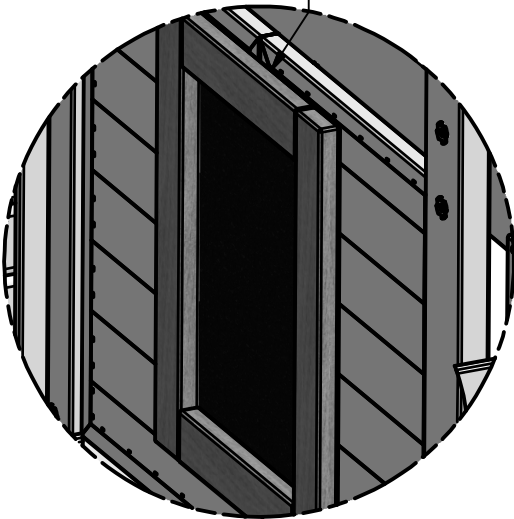

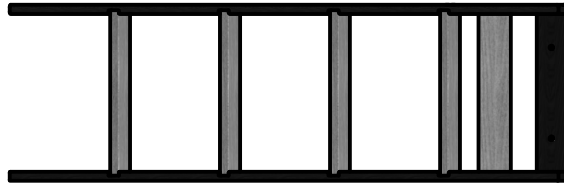

(1) LADDER ASSEMBLY

STEP 50

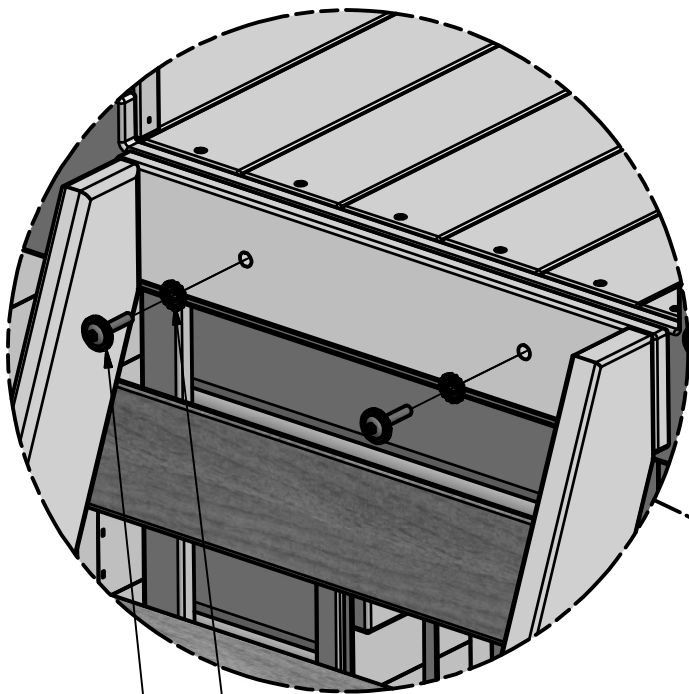
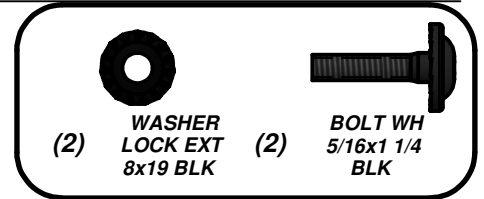

WASHER LOCK EXT 8x19 BLK (2 PLCS)

BOLT WH 5/16x1 1/4 BLK (2 PLCS)

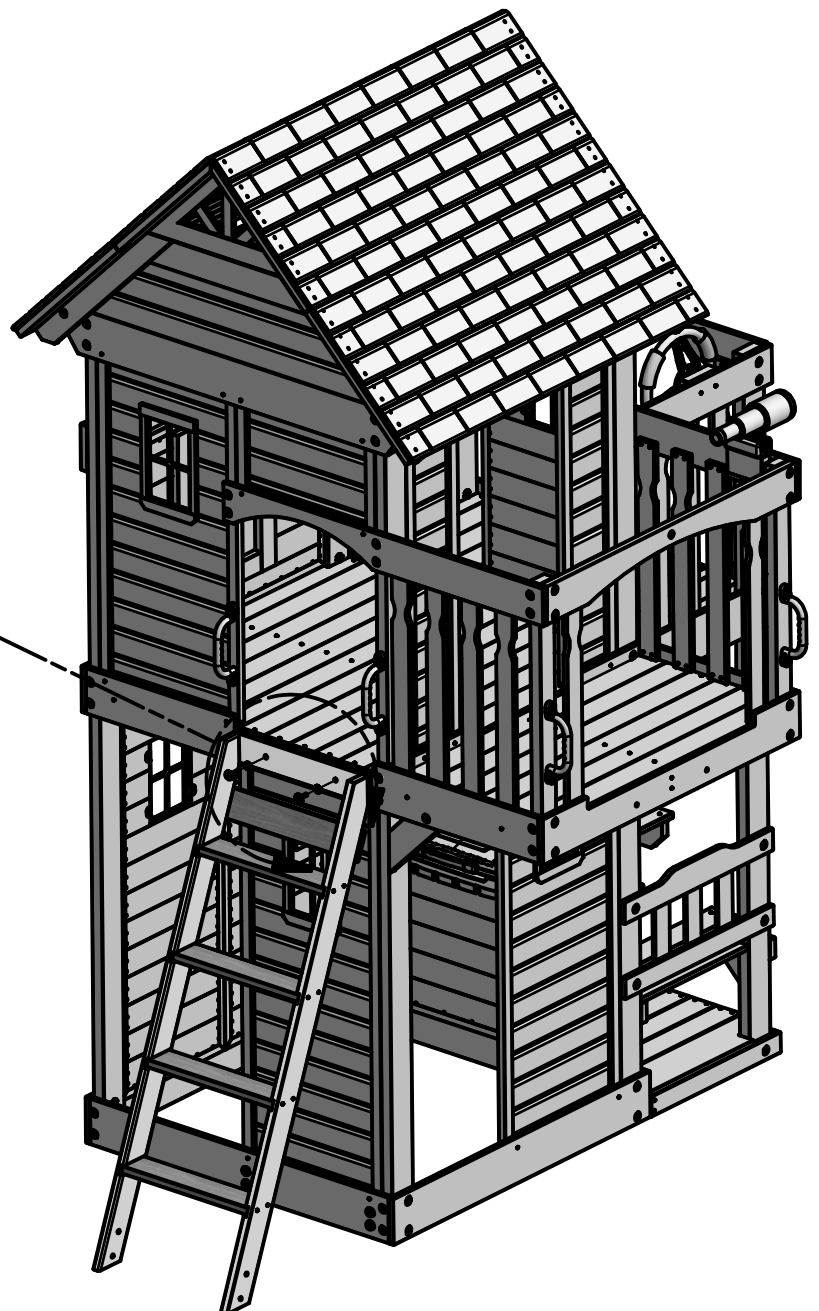

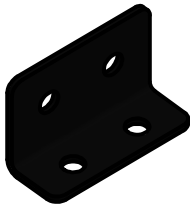

(2) - L BRACKET 51x32x82x3.175 - A4M00855

NUT BARREL WH 5/16x5/8 BLK
(4 PLCS)

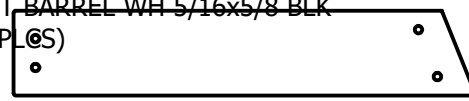

(2) L5 - GROUND BOARD - W4L11652
5/8"x4 3/8"x24 1/8" (16x112x612)

STEP 51

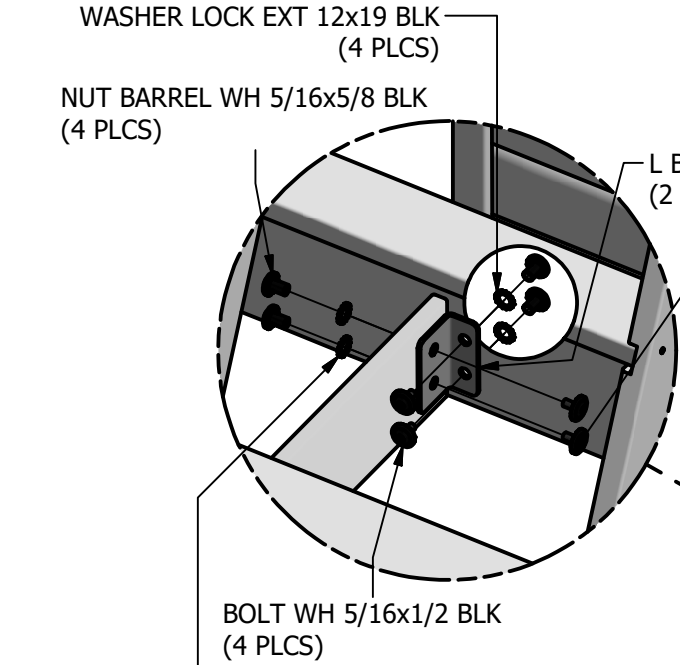

WASHER LOCK EXT 12x19 BLK (4 PLCS)

WASHER LOCK EXT 8x19 BLK (4 PLCS)

BOLT WH 5/16x1 BLK (4 PLCS)

L5

WASHER LOCK EXT 12x19 BLK (4 PLCS)

NUT BARREL WH 5/16x7/8 BLK (4 PLCS)

(8) BOLT WH 5/16x1/2 BLK	(4) BOLT WH 5/16x1 BLK	(4) WASHER LOCK EXT 8x19 BLK
(8) NUT BARREL WH 5/16x5/8 BLK	(4) NUT BARREL WH 5/16x7/8 BLK	(12) WASHER LOCK EXT 12x19 BLK

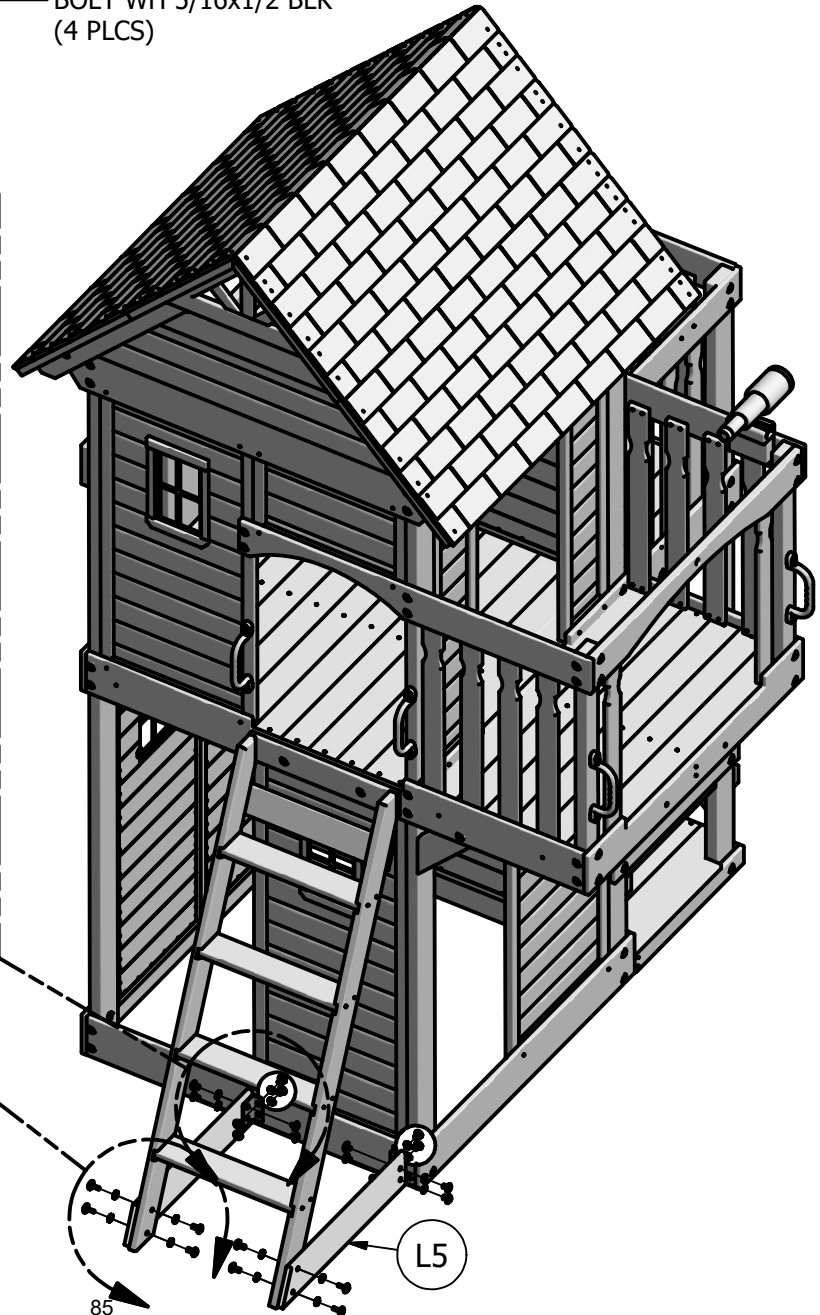

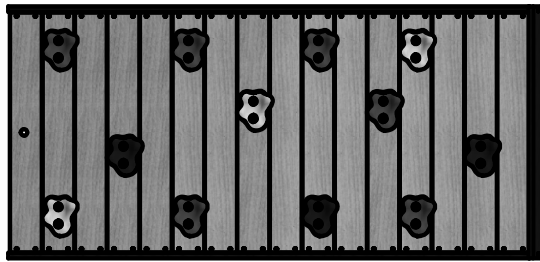

(1) ROCKWALL ASSEMBLY

STEP 52

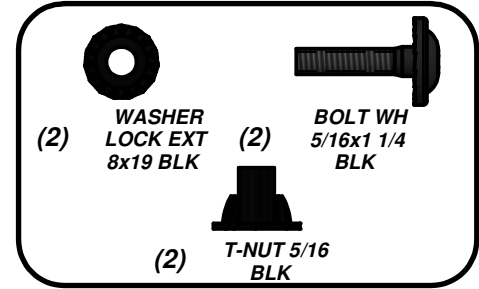
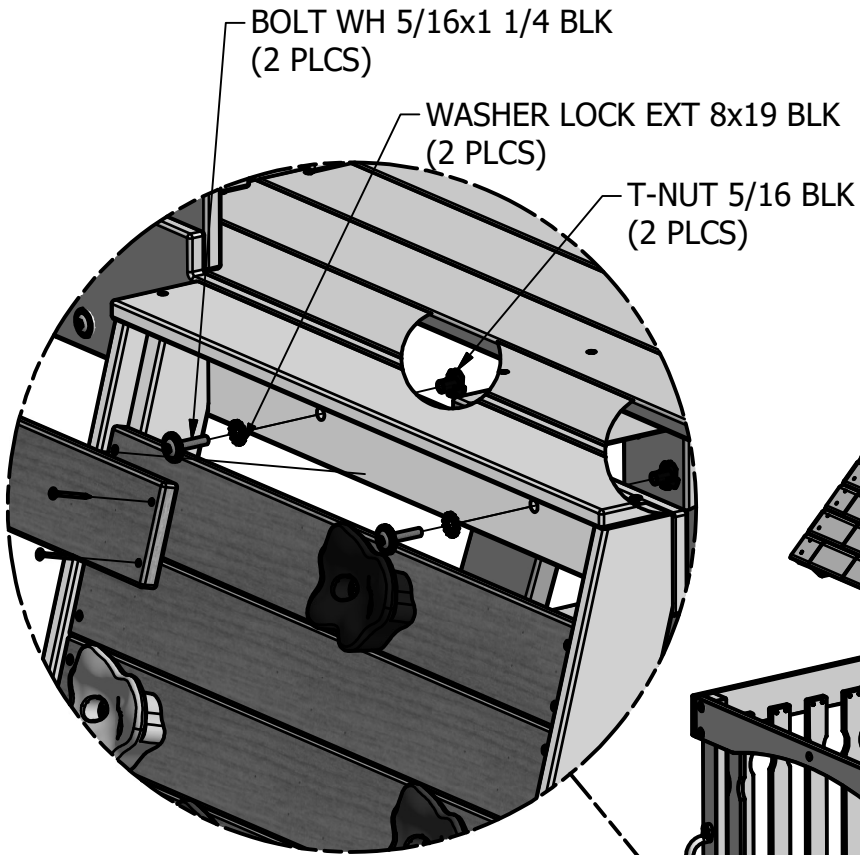

ROCKWALL ASSEMBLY

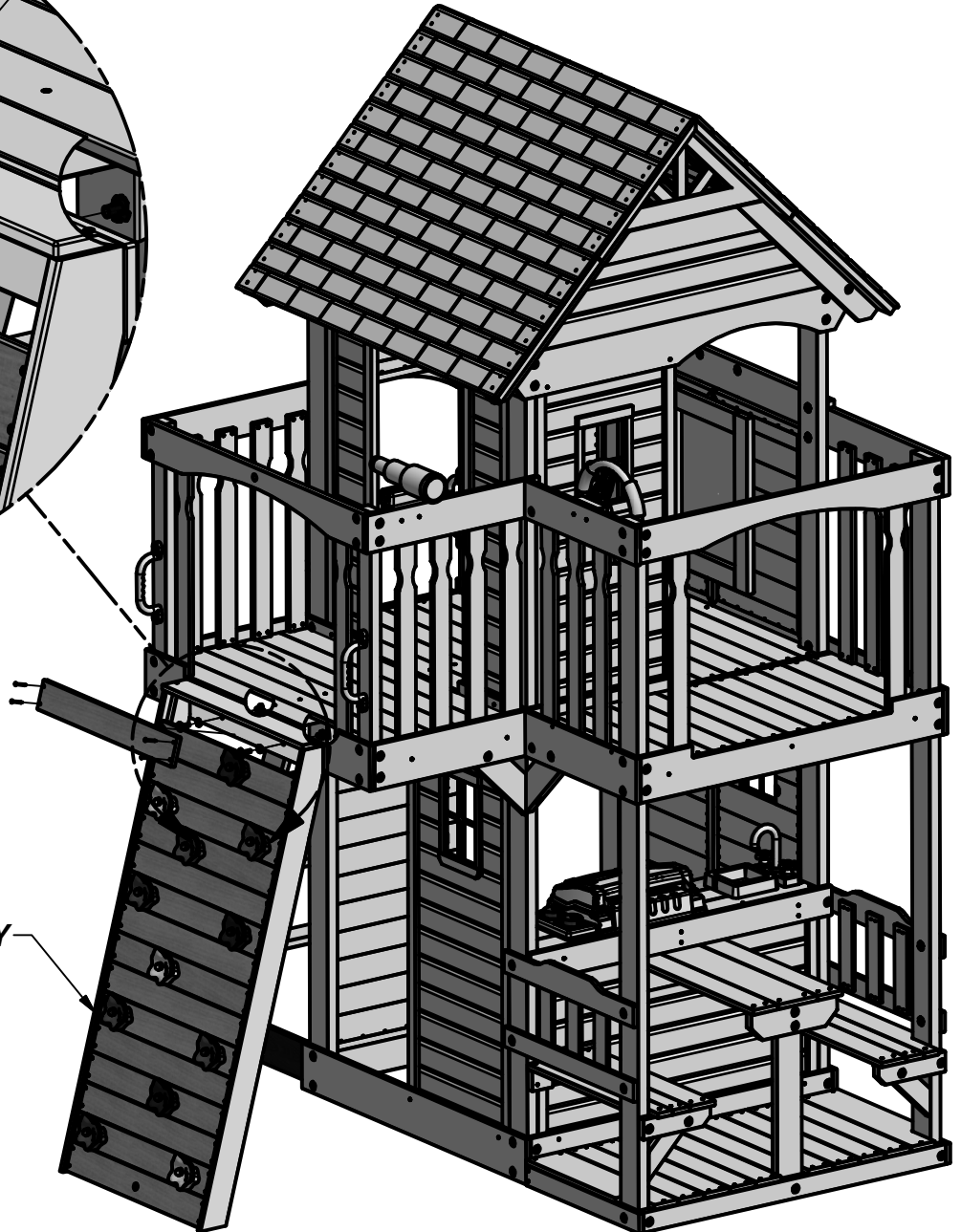

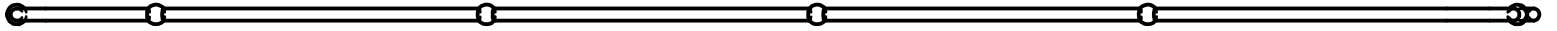

(1) - CLIMBING ROPE - A6P00260

STEP 53

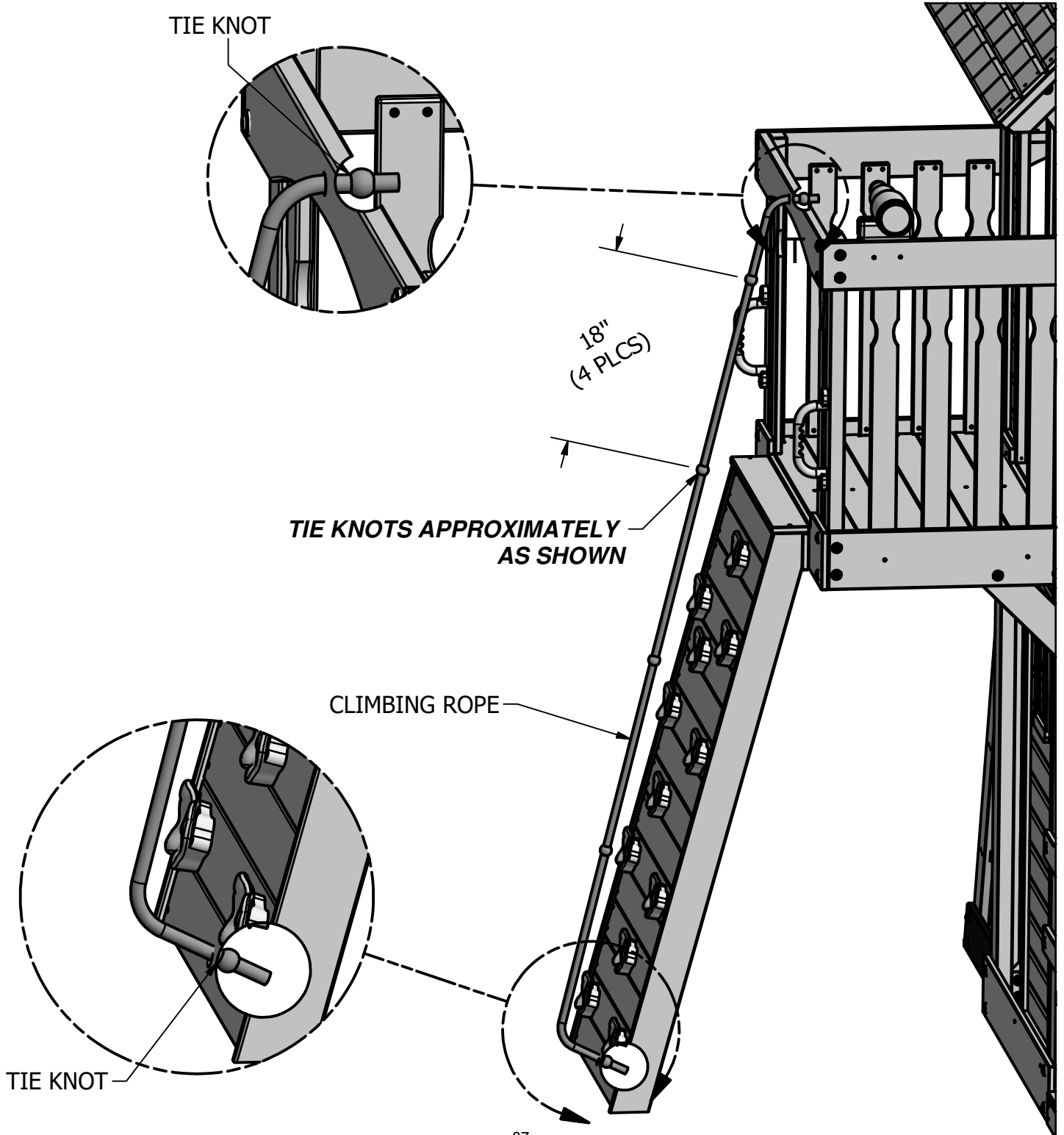



(1) QU - SLIDE VF 10 FT - A100287 OR 50250



(1) O70 - SLIDE MOUNTING BOARD - W4L09040
5/8"x1 3/8"x20 3/8" (16x34x517)

STEP 54

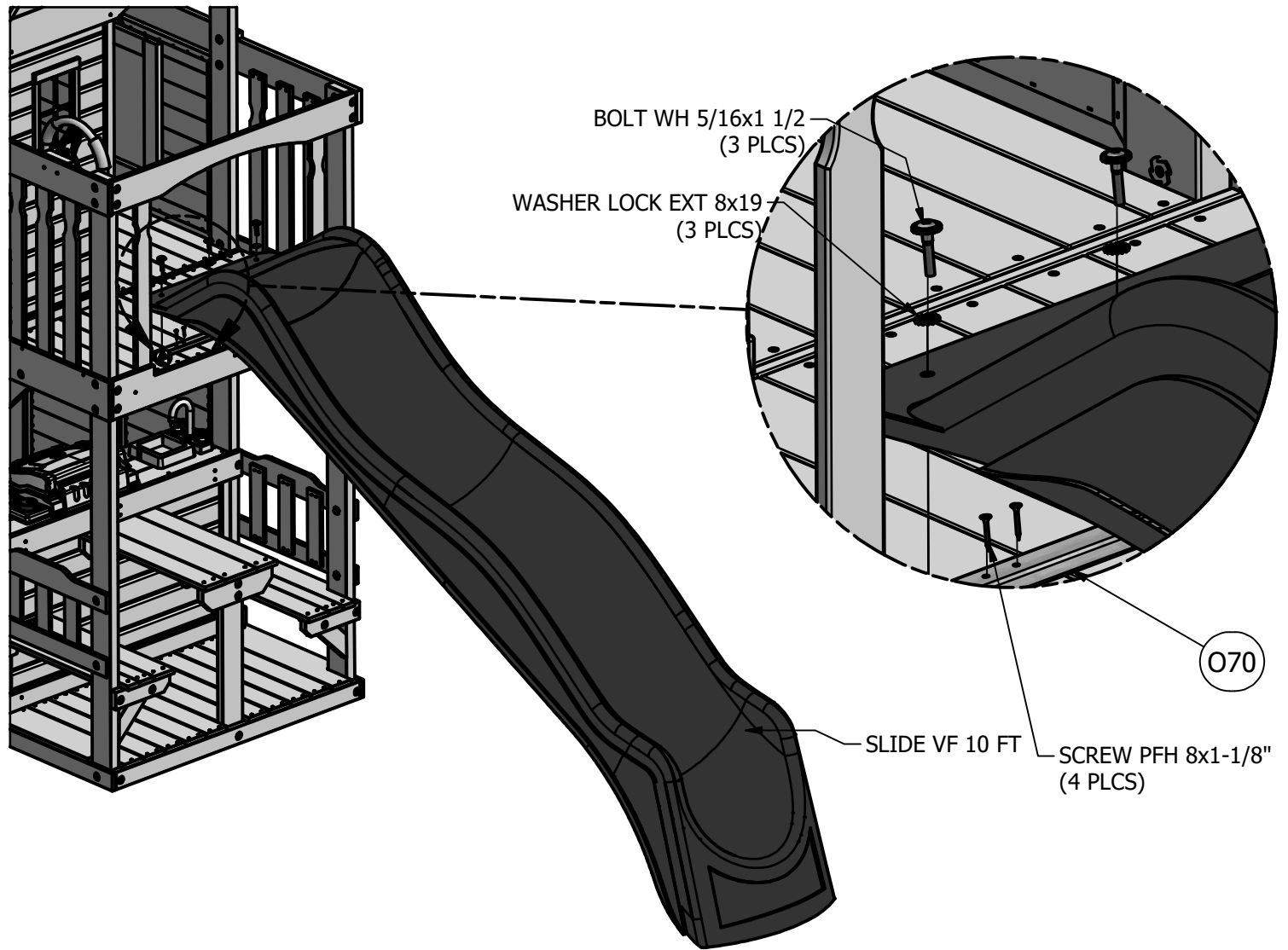
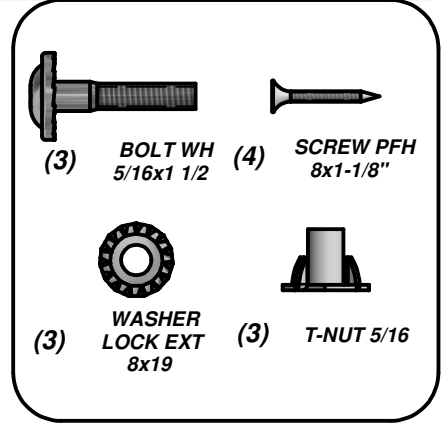
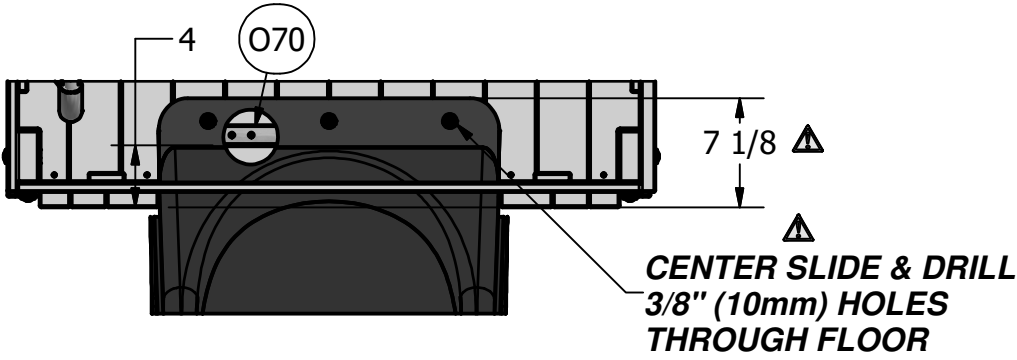

(1) SWING BEAM ASSEMBLY

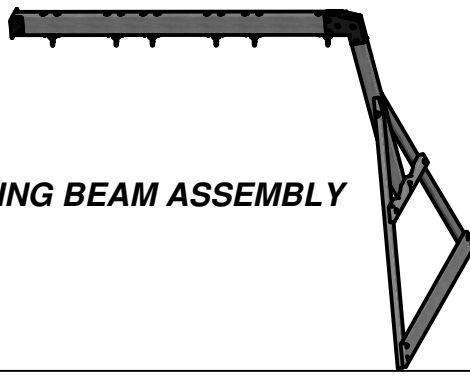

STEP 55

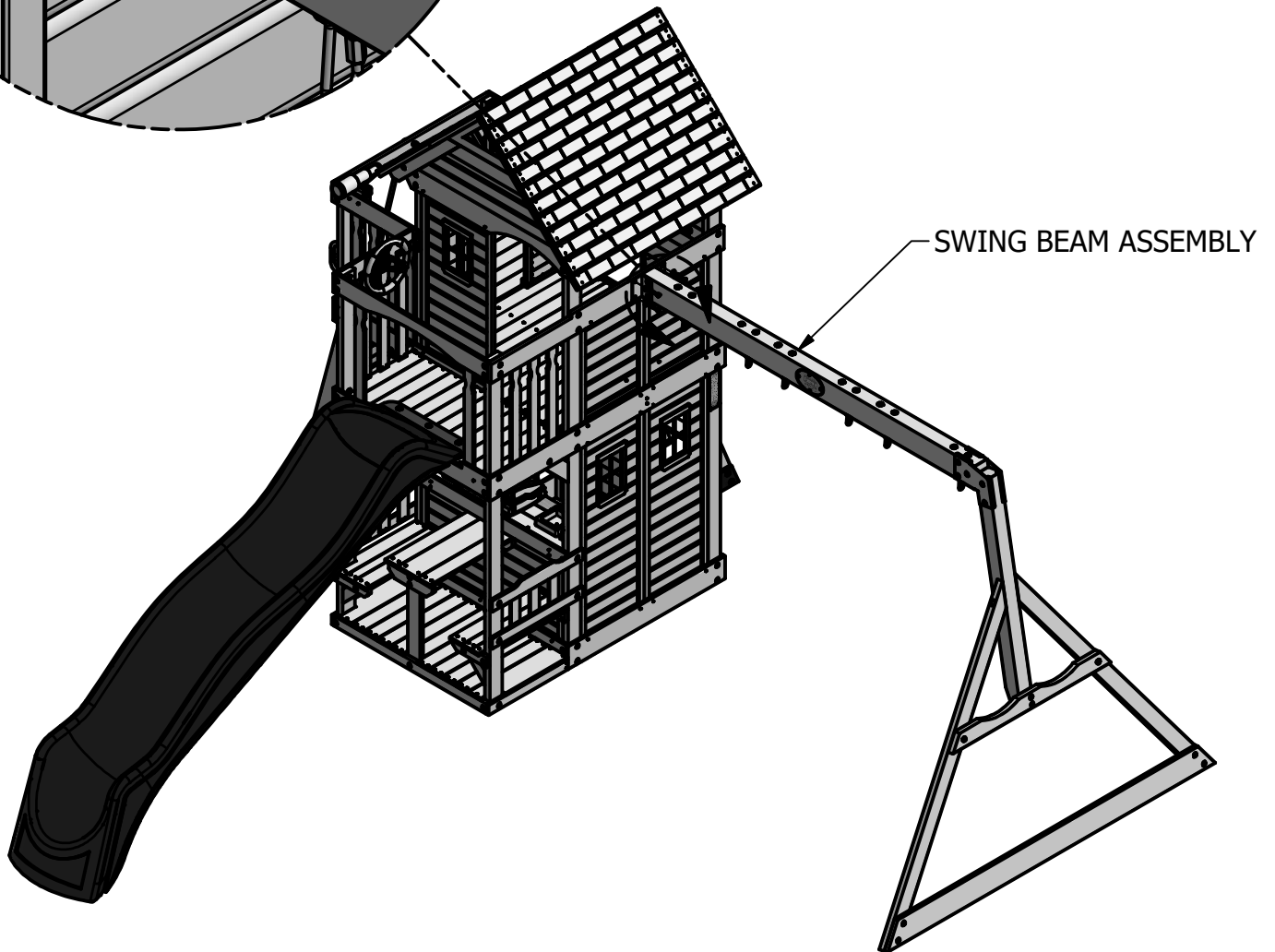
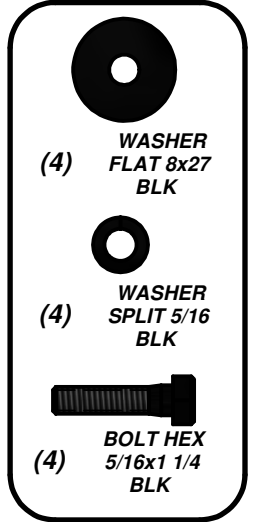
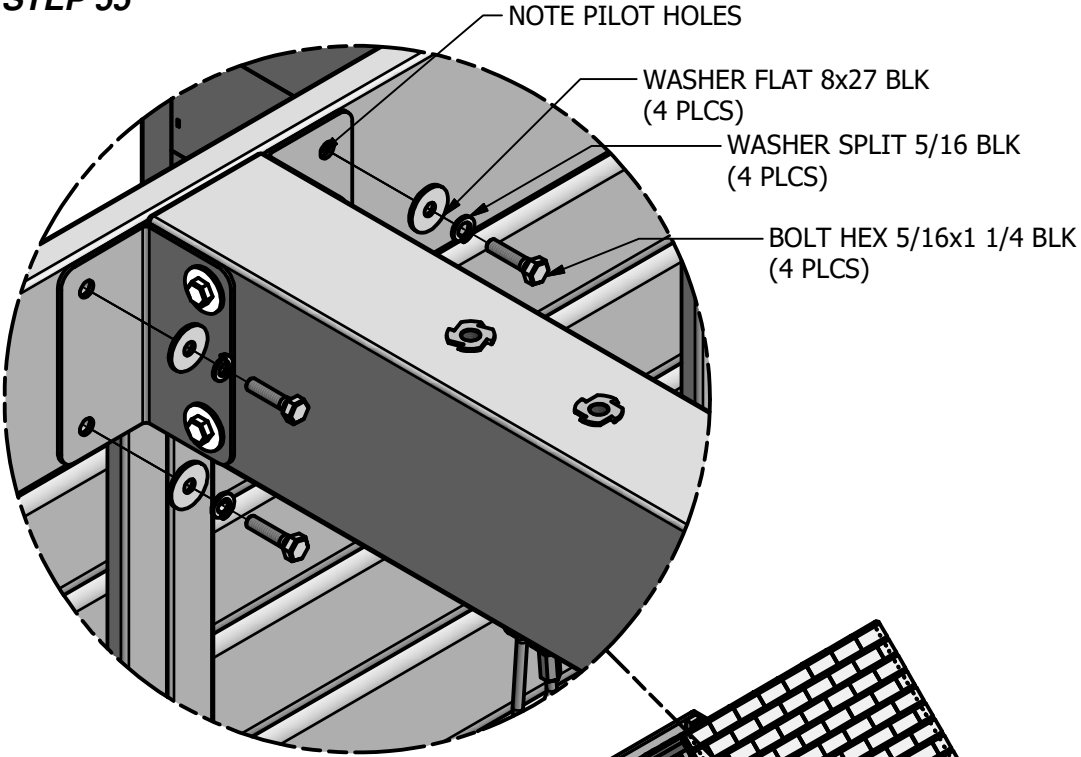



(1) - BYD ID TAG (LARGE) AGES 3-10 - A100164

STEP 56

ALIGN ID TAG IN THE CENTER OF SWING BEAM

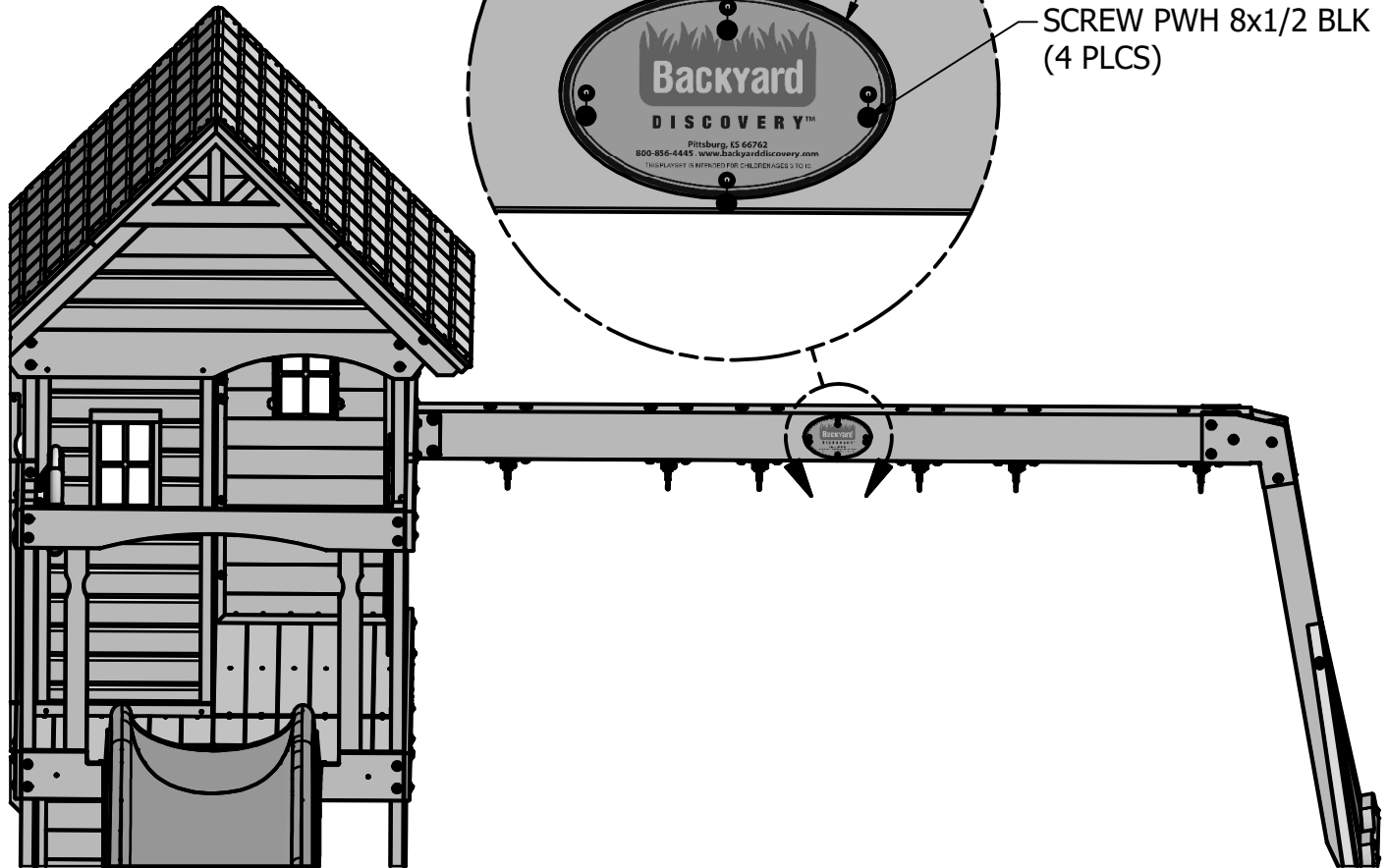
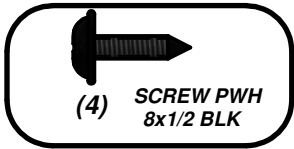



(4) - CHAIN GREEN 51.25" - A100068



(2) - SWING SEAT GREEN 22" - A6P00054



(1) - 21" WEB SWING SEAT - A6P00285

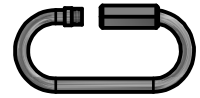

(4) - QUICK LINK - A100069

STEP 57

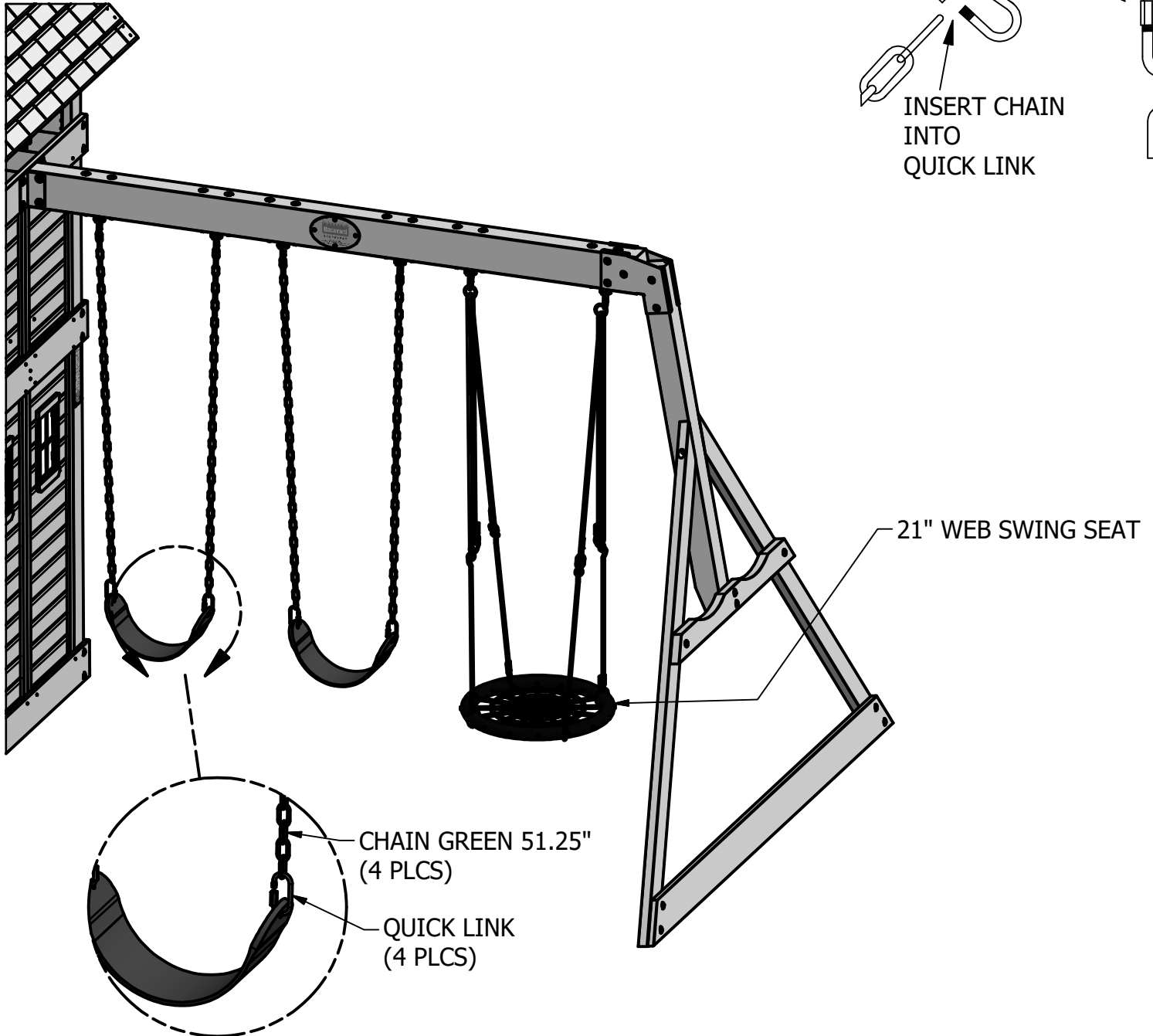

STEP 58

Anchoring Instructions

TAP IN GROUND STAKES AT AN APPROXIMATE 45° ANGLE AT THE LOCATIONS SHOWN. USING GROUND STAKES AS A GUIDE, DRILL 7/16" DIA HOLES.

NOTE:
FAILURE TO USE GROUND STAKES CAN VOID WARRANTY & CAUSE INJURY!

(6)	WASHER LOCK EXT 12x19 BLK	(6)	BOLT WH 5/16x1/2 BLK
(2)	NUT BARREL WH 5/16x7/8 BLK	(4)	NUT BARREL WH 5/16x5/8 BLK

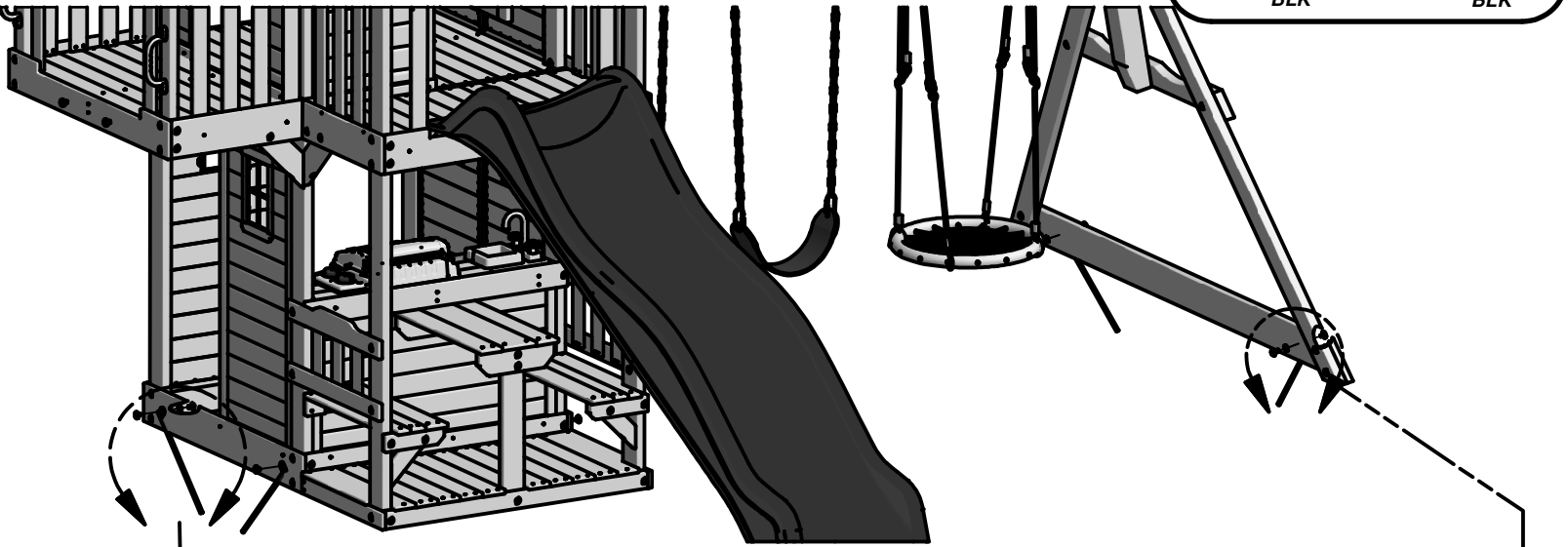

FORT GROUND STAKES

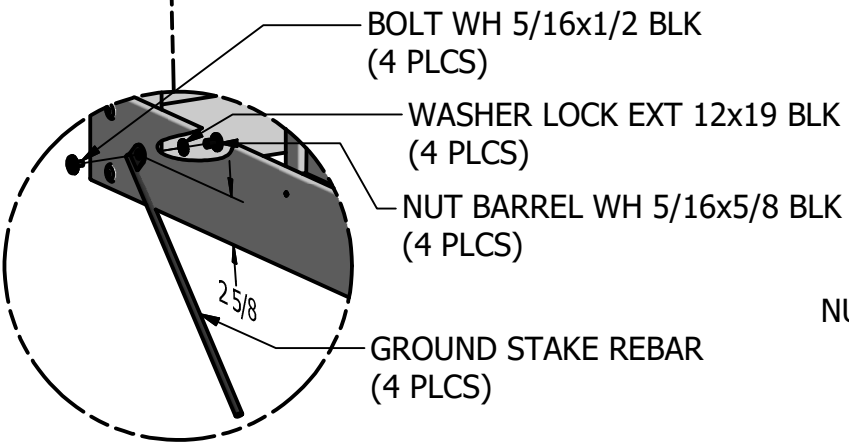

SWING BEAM GROUND STAKES

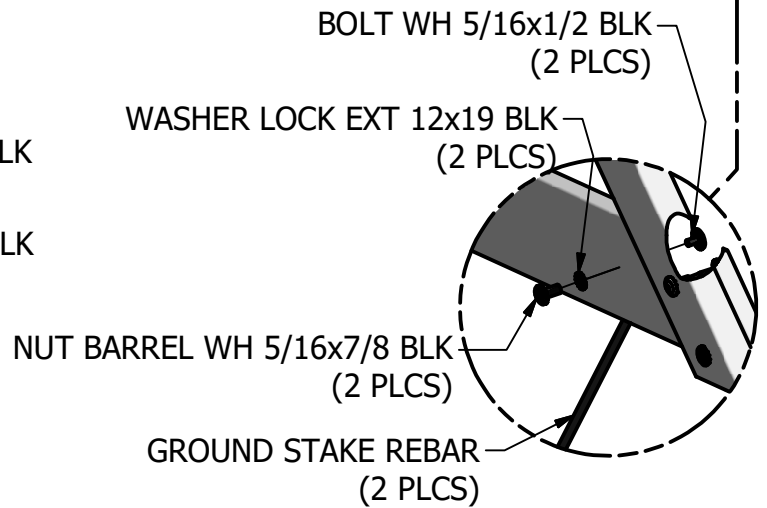

FINAL STEP

DOUBLE CHECK EVERY BOLT, SCREW AND NUT FOR TIGHTNESS. MAKE SURE EVERY BOARD IS SECURE AND MAKE SURE THE PLAY SET IS LEVEL.

ENJOY YOUR NEW PLAY SET!