



KING KING CANADA

POWER FORCE

6500W GASOLINE GENERATOR WITH WHEEL KIT



Read this manual. Do not attempt to operate this generator until you have read and understood the safety, operation, and maintenance instructions

MODEL: KCG-6502GE

INSTRUCTION MANUAL

COPYRIGHT © 2021 ALL RIGHTS RESERVED BY KING CANADA TOOLS INC.



WARRANTY & SERVICE INFORMATION

**1-YEAR
LIMITED WARRANTY
FOR THIS 6500W GASOLINE GENERATOR**

**KING CANADA TOOLS
OFFERS A 1-YEAR LIMITED WARRANTY
FOR NON-COMMERCIAL USE.**



BEFORE CALLING THE ABOVE TOLL-FREE NUMBER, PLEASE READ THIS MANUAL, SPECIFICALLY THE SAFETY PRECAUTIONS, THE INSPECTION BEFORE OPERATION AND THE TROUBLESHOOTING GUIDE.

- **DO NOT RETURN THE DEFECTIVE PRODUCT TO THE RETAILER.**

WARRANTY INFORMATION

PROOF OF PURCHASE

Please keep your dated proof of purchase for warranty and servicing purposes.

REPLACEMENT PARTS

Replacement parts for this generator are available at our authorized KING CANADA generator service centers across Canada. For servicing, call the above toll free number to get servicing instructions and be sure to have your proof of purchase if you are claiming warranty work. Please use the 10 digit part numbers listed in this manual for all part orders where applicable.

LIMITED TOOL WARRANTY

KING CANADA makes every effort to ensure that this product meets high quality and durability standards. KING CANADA warrants to the original retail consumer a 1-year limited warranty as of the date the product was purchased at retail and that each product is free from defects in materials.

THIS WARRANTY IS NOT TRANSFERABLE AND DOES NOT COVER

- Damage or liability caused by shipping, improper handling, improper installation, improper maintenance, improper modification, or the use of accessories and/or attachments not specifically recommended.
- Repairs necessary because of operator abuse or negligence, or the failure to install, operate, maintain, and store the product according to the instructions in the owner's manual.
- Damage caused by cold, heat, rain, excessive humidity, corrosive environments and materials, or other contaminants.
- Expendable items that become worn during normal use such as fuel filters, air cleaners, spark plugs, and engine oil.
- Cosmetic defects that do not interfere with product functionality.
- Freight costs from customer to an authorized warranty service location.
- Repair and transportation costs of products or parts determined not to be defective.
- ANY INCIDENTAL, INDIRECT OR CONSEQUENTIAL LOSS, DAMAGE, OR EXPENSE THAT MAY RESULT FROM ANY DEFECT, FAILURE OR MALFUNCTION OF THE PRODUCT.

- **RETAIN THE ORIGINAL CASH REGISTER SALES RECEIPT AS PROOF OF PURCHASE FOR WARRANTY WORK.**

KING CANADA shall in no event be liable for death, injuries to persons or property or for incidental, special or consequential damages arising from the use of our products. Shipping and handling charges may apply. If a defect is found, KING CANADA will either repair or replace the product.

BASIC & SPECIFIC SAFETY PRECAUTIONS



BE CAREFUL!

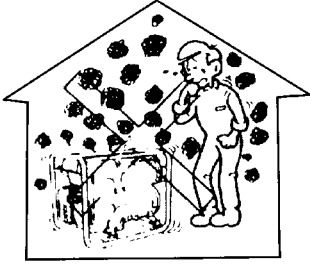

**DO NOT USE
IN YOUR HOUSE**

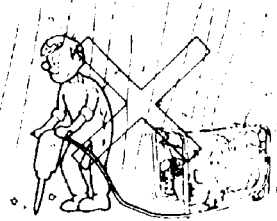

**DO NOT USE IN
WET CONDITIONS**

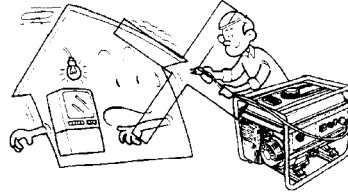

**DO NOT CONNECT TO
HOUSEHOLD CIRCUIT**

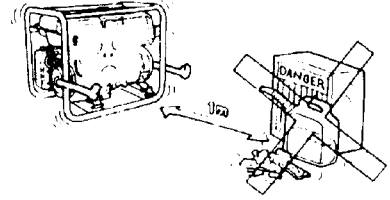

**KEEP FLAMMABLE
MATERIALS AWAY**

WHEN REFUELING:

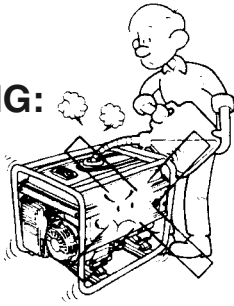

STOP ENGINE!

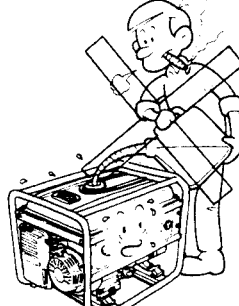

NO SMOKING!

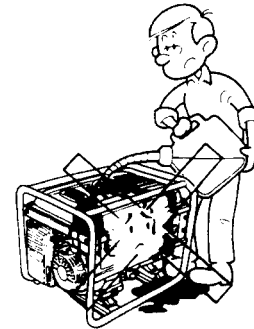

DO NOT SPILL GASOLINE!

BASIC SAFETY INFORMATION

EXHAUST FUMES ARE DANGEROUS

•Never operate the engine in a closed area or it may cause unconsciousness and death within a short time. Operate in a well ventilated area.

FUEL IS HIGHLY FLAMMABLE AND POISONOUS

- Always turn off the engine when refueling.
- Never refuel while smoking or in the vicinity of an open flame.
- When operating or transporting this generator, be sure to keep it upright. If it tilts, fuel may leak from the carburetor or fuel tank.

ENGINE AND MUFFLER MAY BE HOT

- Place the generator in an appropriate location, away from children and pedestrians.
- Avoid placing any flammable materials near the exhaust outlet during operation.
- Keep a 4ft. clearance from buildings or other equipment around the generator to prevent overheating.

ELECTRIC SHOCK PREVENTION

- Never operate in rain or snow.
- Never touch the generator with wet hands or electric shock will occur.
- Be sure to ground (earth) the generator.

ELECTRICAL CONNECTION NOTES

- Avoid connecting the generator to commercial power outlet.
- Avoid connecting the generator in parallel with any other generator.

WARNING! The engine muffler will be very hot after use, avoid touching the engine or muffler while they are still hot.

FUEL

Make sure there is sufficient fuel in the tank.

GROUNDING

Make sure to ground (earth) the generator.

SPECIFIC SAFETY INFORMATION

Attempting to connect generator directly to the electrical system of any building structure.

Back feeding electricity through a building's electrical system to the outside utility feed lines could endanger repair persons attempting to restore service.

Failure to use a double throw transfer switch when connecting to a structure's electrical system can damage appliances and **WILL VOID** the manufacturer's warranty.

Never backfeed electricity through a structure's electrical system. To connect to a structure's electrical system in a safe manner, always have a Double-Throw Transfer Switch installed by a qualified electrician and in compliance with local ordinances. (When installing a Double-Throw Transfer Switch, a minimum of 10 gauge wiring must be used).



SPECIFIC SAFETY PRECAUTIONS

OPERATION OF GENERATOR IN RAIN, WET, ICY, OR FLOODED CONDITIONS.

Water is an excellent conductor of electricity! Water which comes in contact with electrically charged components can transmit electricity to the frame and other surfaces, resulting in electrical shock to anyone contacting them.

Operate generator in a clean, dry, well ventilated area. Make sure hands are dry before touching unit.

TAMPERING WITH FACTORY SET ENGINE SPEED SETTINGS.

Engine speed has been factory set to provide safe operation. Tampering with the engine speed adjustment could result in overheating of attachments and could cause a fire.

Never attempt to "speed-up" the engine to obtain more performance. Both the output voltage and frequency will be thrown out of standard by this practice, endangering attachments and the user.

IMPROPER CONNECTION OF ITEMS TO GENERATOR.

Exceeding the load capacity of the generator by attaching too many items, or items with very high load ratings to it could result in overheating of some items or their attachment wiring resulting in fire or electrical shock. Make sure that the sum total of electrical loads for all attachments does not exceed the load rating of the generator.

ATTEMPTING TO FILL THE FUEL TANK WHILE THE ENGINE IS RUNNING.

Gasoline and gasoline vapors can become ignited by coming in contact with hot components such as the muffler, engine exhaust gases, or from an electrical spark.

Turn engine off and allow it to cool before adding fuel to the tank. Equip area of operation with a fire extinguisher certified to handle gasoline or fuel fires.

SPARKS, FIRE, HOT OBJECTS

Cigarettes, sparks, fires, or other hot objects can cause gasoline or gasoline vapors to ignite.

Add fuel to tank in well ventilated area. Make sure there are no sources of ignition near the generator.

INADEQUATE VENTILATION FOR GENERATOR

Materials placed against or near the generator or operating the generator in areas where the temperature exceeds 40° C ambient (such as storage rooms or garages) can interfere with its proper ventilation features causing overheating and possible ignition of the materials or buildings.

Operate generator in a clean, dry, well ventilated area a minimum of four feet from any building, object or wall. **DO NOT OPERATE UNIT INDOORS OR IN ANY CONFINED AREA.**

RISK OF BREATHING - INHALATION HAZARD

Operate generator in clean, dry, well ventilated area. Never operate unit in enclosed areas such as garages, basements, storage, sheds, or in any location occupied by humans or animals.

Keep children, pets and others away from area of operating unit. Breathing exhaust fumes will cause serious injury or death. **Gasoline engines produce toxic carbon monoxide exhaust fumes.**

OPERATION OF VOLTAGE SENSITIVE APPLIANCES WITHOUT A VOLTAGE SURGE PROTECTOR.

Any gasoline operated household generator will incur voltage variations causing damage to voltage sensitive appliances or could result in fire.

Always use a U.L./CSA listed voltage sensitive surge protector to connect voltage sensitive appliances (TV, computer, stereo, etc.). Failure to use a U.L./CSA listed voltage surge protector will void the warranty on your generator.

Notice: A multiple outlet strip is not a surge protector. Make sure you use a U.L./CSA listed voltage surge protector.

USE OF WORN, DAMAGED, UNDERSIZED OR UNGROUNDED EXTENSION CORDS.

Contact with worn or damaged extension cords could result in electrocution. Use of undersize extension cords could result in overheating of the wires or attached items, resulting in fire.

Use of ungrounded extension cords could prevent operation of circuit breakers and result in electrical shock.

Inspect extension cords before use and replace with new cord if required. Use proper size (wire gauge) extension cords for application as shown below. Always use extension cords having a grounding wire with an appropriate grounding plug. **DO NOT** use an ungrounded plug.

An extension cord that is hot to the touch is overloaded. Repair or replace damaged extension cords immediately.

<u>Cord Length</u>	<u>Wire Gauge Size</u>	<u>Amps</u>
0-100 FEET	NO.12	Up to 20 Amps.
0-100 FEET	NO.10	Up to 30 Amps.

GETTING TO KNOW YOUR GENERATOR

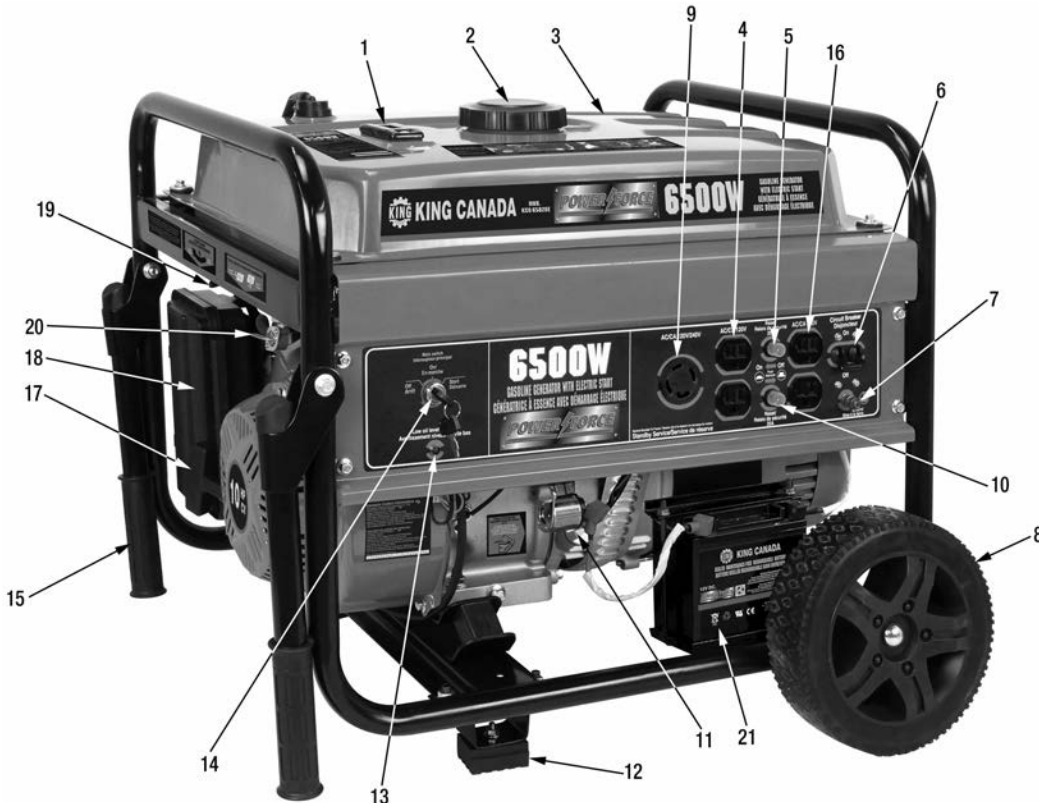

IMPORTANT

To obtain max wattage, use the standard 120V double receptacles together as shown below. (Max 40A).

Note: If drawing 10 Amp. from a 120V double receptacle, only 10 Amp. are available for use from the 120V/240V L14-30 Nema receptacle. If drawing 20 Amp. from a 120V double receptacle, 0 Amp. are available for use from the 120V/240V L14-30 Nema receptacle.

To obtain max wattage from the 120V/240V L14-30 Nema receptacle, do not use either 120V double receptacles.

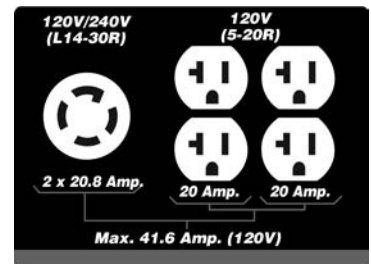

1. **Fuel level indicator window with float gauge.**
2. **Fuel cap.** Make sure the fuel cap is always screwed on tightly.
3. **Fuel tank.** Unleaded gasoline only! 20 Liter capacity.
4. **1 of 2 Duplex AC 120V outlets.** Plug up to 2-120V appliances or a power bar, make sure the amps requirement does not exceed max amps or else the AC breaker will automatically shut-off the power output.
5. **20 Amp. Reset.** Resets the corresponding dual 120V AC outlet.
6. **AC Double throw circuit breaker.** The AC breaker turns off automatically when the load exceeds the generator rated output. Reduce the load to within specified generator rated output if AC breaker turns off.
7. **Grounding terminal.** This generator must be grounded, see grounding instructions.
8. **10" Wheels.**
9. **AC 120V/240V Twist lock outlet.** This NEMA L14-30 twist lock outlet allows 120V or 240V operation, see instructions further in this manual.
10. **20 Amp. Reset.** Resets the corresponding dual 120V AC outlet.
11. **Oil gauge dipstick.** Check the oil level using this oil gauge dipstick.
12. **Frame supports.**
13. **Low oil warning indicator light.** This generator detects and shuts off automatically when the oil level is too low. In case of an auto shut-off and the indicator light is ON, check oil level with dipstick (#11) and fill to recommended level with SAE 10W30 engine oil.
14. **Electric Start Power ON Key Switch.** To turn engine on, first turn key to ON, make sure low oil warning light does not come on, turn key further and hold until engine starts and release. Move switch to Off position to stop generator.
15. **Transport Pivot Handle.**
16. **1 of 2 Duplex AC 120V outlets.** See #4 above.
17. **Recoil starter.** Starts the engine.
18. **Air cleaner element/cover.** Periodically the air cleaner filter must be checked and maintained, see maintenance section.
19. **Carburetor throttle lever (choke).** Once the engine is started, it is necessary to gradually push in the carburetor throttle lever to the "OPEN" position, see instructions further in this manual.
20. **Fuel Shut-off Valve.** Regulates the flow of fuel to the engine. The fuel shut-off valve must be fully opened before starting the engine.
21. **12V Battery.** Powers the electric start.

MODEL	KCG-6502GE
Peak Wattage (starting)	6,500W
Running Wattage	5,000W
AC current (120V/240V)	41.6 Amp./20.8 Amp.
Engine (OHV)	10 HP
No load speed	3,750 RPM
Displacement (cc)	274
Fuel	Unleaded Gasoline
Fuel tank (L)	20
Oil capacity (L)	0.7
Run time	7-8 hrs.
Noise level	75 dB(A)
Dimensions (LxWxH)	24-1/4" x 24-1/2" x 21"
Weight	130 lbs



ASSEMBLY & PRE-START CHECK

WARNING! To prevent permanent damage to generator or any appliances, you **MUST** check oil level, fuel level, air cleaner filter and unplug any load from the generator before starting.

ASSEMBLY

Remove all the contents from the carton and proceed to the following assembly steps:

Wheels

To install a wheel (B) Fig.1 to the right end of the frame, insert bolt (A) through the wheel, then slide washer (C) on opposite side of the wheel. Insert bolt through the mounting hole in the frame. Secure the wheel by inserting a retaining clip (D) into the hole in the end of the bolt. Repeat for the second wheel.

Pivot handles & frame supports

Install the pivot handles (A) Fig.1A to the left side of the frame using 2 hex. bolts and hex. nuts. Install the frame supports (B) to the frame using hex. bolts and hex. nuts.

PRE-START CHECK

OIL LEVEL

WARNING! This generator has been shipped from the factory without oil or very little oil in the crankcase. Operating the unit without the correct amount of oil can damage the engine. Oil crankcase capacity: 0.7 litres.

Always check the oil level before starting the generator, make sure the generator is on a level surface. To check oil level:

- 1) Turn the oil gauge dipstick (A) Fig.1B counterclockwise, remove it and clean it with a clean cloth.
- 2) Fully reinsert the oil gauge dipstick and pull it out to check the oil level.
- 3) If the oil level is halfway up the dipstick or below, refill with SAE 10W30 oil through the dipstick hole until the oil level reaches 3/4 up the dipstick or until it reaches the bottom lip of the dipstick hole as shown in illustration below.

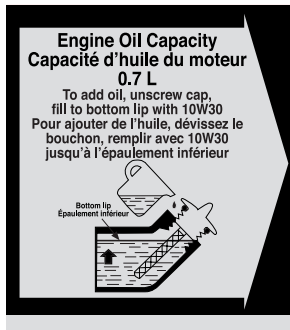

- 4) Reposition the oil gauge dipstick and tighten it by turning clockwise.

FUEL LEVEL

WARNING! Make sure there is enough fuel in the fuel tank before operating.

- 1) Check the fuel level indicator window (A) Fig.2, if the orange float gauge is all the way up, it is not necessary to add fuel. If you do not see or hardly see the orange float gauge, it is necessary to add fuel.
- 2) If it is necessary to add fuel, first make sure the engine is OFF, then open the fuel cap (B) Fig.2 by turning it counterclockwise.
- 3) Make sure the fuel filter cup (C) is positioned inside the tank opening before refueling.
- 4) When refueling, keep in mind all safety precautions and make sure to add enough fuel based on usage. A full tank will give you 7-8 hours of operation. Use clean unleaded gasoline with a minimum of 87 octane. Do not mix oil with gasoline. Fuel tank capacity: 20 Litres.

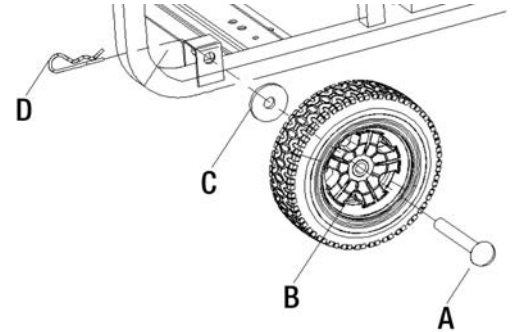

Figure 1



Figure 1A

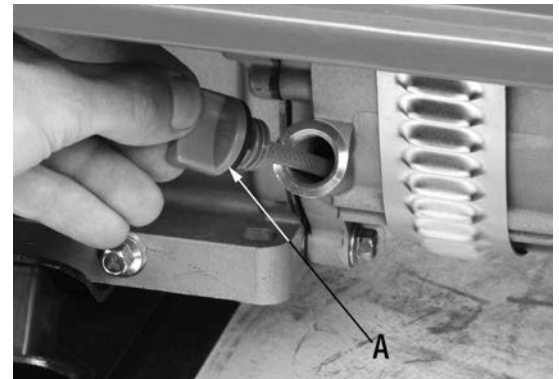

Figure 1B

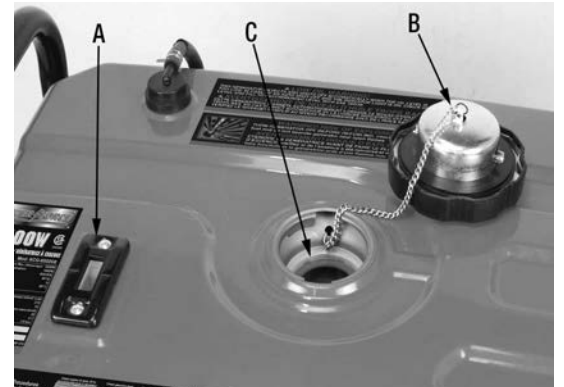

Figure 2

PRE-START CHECK & STARTING PROCEDURES



PRE-START CHECK

AIR CLEANER FILTER

The air cleaner filter should be checked before every start-up and after prolonged storage, the following steps should be done when checking air cleaner filter:

- 1) Snap the two side clips (A) Fig.3 backwards and remove the air cleaner cover (B).
- 2) Remove the air cleaner filter (C), shake off debris and dust, blow with air if needed.
- 3) Reposition filter and the air cleaner filter cover.

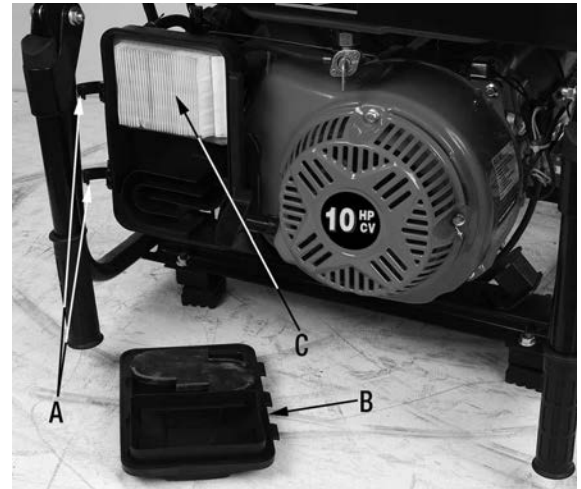

Figure 3

STARTING PROCEDURES

GROUNDING

WARNING! BEFORE STARTING, YOUR GENERATOR MUST BE GROUNDED!

Before operating make sure to ground the generator. A ground terminal identified by the ground symbol (Fig.4) can be found on the front control panel of the generator, attach a metal spike to a wire, attach the wire to the ground terminal and ground the metal spike into the earth. Your local electrical company or certified electrician should be able to help you with this information. See Fig.4.

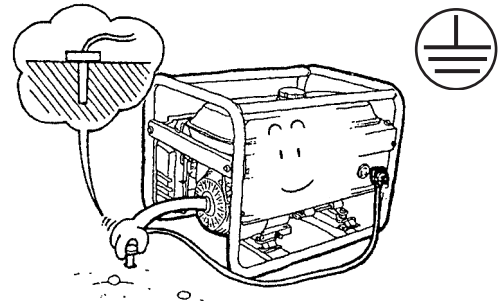

Figure 4

STARTING YOUR GENERATOR

WARNING! Do not adjust or attempt maintenance of engine without consulting an authorized service center. Never run engine indoors or in enclosed, poor ventilated areas, engine exhaust contains carbon monoxide, an odorless and deadly gas! Make sure all electrical appliances are unplugged before attempting to start generator!

To safely start your generator, follow the steps 1 through 8 in Fig.5 below.

Check engine oil level, fill to recommended level if necessary



Check gasoline level



Disconnect all electrical devices from the electrical panel



Open fuel valve ("On" position)



Close the Choke rod



Turn key to start position, once engine starts, release key



Pull recoil starter to start engine



Open choke lever



Figure 5

Note: No choke is required on warm engines. Pull the recoil starter handle until resistance is felt, then pull it out with a rapid full arm stroke. Let the starter rope rewind slowly, repeat if necessary. Allow generator to run at no load for 5 minutes upon each initial start-up to allow engine and generator to stabilize. **IF ENGINE OIL LEVEL IS TOO LOW, ENGINE WILL NOT START. CHECK OIL LEVEL AND ADD IF NECESSARY.**



STOPPING PROCEDURES & ELECTRICAL CONNECTIONS

STOPPING PROCEDURES

STOPPING YOUR GENERATOR

Make sure all electrical appliances are unplugged before stopping the generator!

- 1) Turn breaker (B) Fig.6 “OFF” by lowering it.
- 2) Turn the key in the engine power switch (A) to the “OFF” position by turning the key counterclockwise.
- 3) Close the fuel shut-off valve (C) by bringing it upwards.

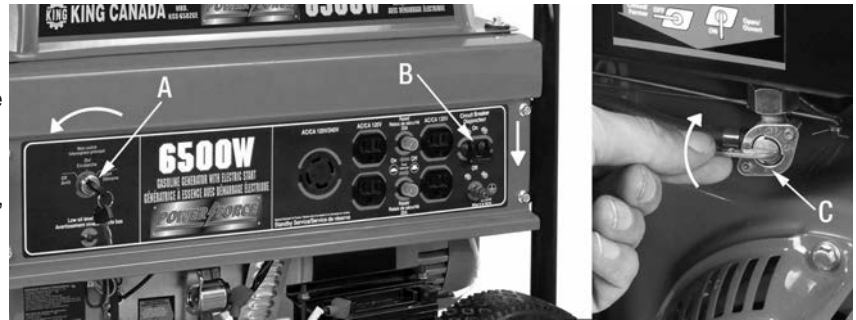

Figure 6

ELECTRICAL CONNECTIONS

CONNECTING ELECTRICAL LOADS

Attempting to connect generator directly to the electrical system of any building structure.

Back feeding electricity through a building’s electrical system to the outside utility feed lines could endanger repair persons attempting to restore service. Failure to use a double throw transfer switch when connecting to a structure’s electrical system can damage appliances and WILL VOID the manufacturer’s warranty. Never backfeed electricity through a structure’s electrical system. To connect to a structure’s electrical system in a safe manner, always have a Double-Throw Transfer Switch installed by a qualified electrician and in compliance with local ordinances. (When installing a Double-Throw Transfer Switch, a minimum of 10 gauge wiring must be used).

IMPROPER CONNECTION OF ITEMS TO GENERATOR

Exceeding the load capacity of the generator by attaching too many items, or items with very high load ratings to it could result in overheating of some items or their attachment wiring resulting in fire or electrical shock. Make sure that the sum total of electrical loads for all attachments does not exceed the load rating of the generator.

WARNING! Failure to connect and operate equipment in the sequence below can cause damage to equipment and will void the warranty.

- 1) Let engine run and warm up for five minutes after starting with no electrical load. Connect loads in the following manner:
- 2) Connect “inductive” load equipment first, inductive loads consist of refrigerators, freezers, water pumps, air conditioners, or small hand tools. Connect the items that require the most wattage first.
- 3) Connect the lights next.
- 4) Voltage sensitive equipment should be the last equipment connected to the generator. Plug voltage sensitive appliances such as TV’s, VCR’s, microwaves, ovens, computers, and cordless telephones into a UL/CSA listed voltage surge protector, then connect the UL/CSA listed voltage surge protector to the generator.

Overloading the generator will cause power fluctuations and can damage equipment and appliances. King Canada will not be responsible for equipment damaged as a result of voltage surges, improper operation or improper installation of the generator.

CONTROL PANEL

120V AC DUPLEX RECEPTACLES & RESETS

For normal 120V operation, plug your appliance or power bar into one of the two duplex 120V receptacles (A & C) Fig.7. Each receptacle has its own reset button (B & D) placed directly next to them.

DUAL 120V/240V AC TWIST LOCK RECEPTACLE

This twist lock receptacle is equipped with a neutral to split the 240V into 2-120V. This 120/240V twist lock receptacle (E) is a NEMA L14-30 twist lock receptacle and requires a NEMA L14-30 plug to make the connection. If you are unsure about the use of this twist lock receptacle or how to wire the supplied plug, contact a qualified electrician for more information.

RESETS AND CIRCUIT BREAKER

The control panel contains 2 reset buttons (20 Amp. resets (B & D) for the duplex 120V receptacles) and a main circuit breaker (F). If an overload occurs (reached maximum capacity), the corresponding reset button and the circuit breaker will “trip” to their “Off” position, causing the generator to automatically shut off. Disconnect all electrical items from the control panel. Press the tripped reset button, then position the circuit breaker to the On position and restart the generator. If the reset and circuit breaker continues to “trip”, the electrical item or items are exceeding the amperage capacity of this generator, reduce electrical charge or use a more powerful generator.

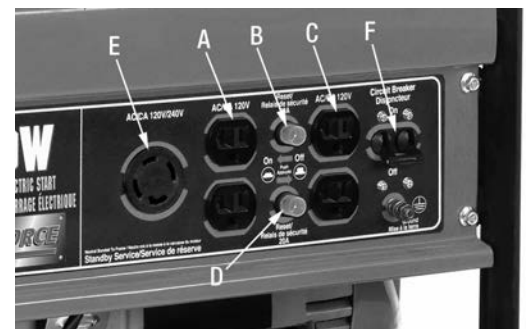

Figure 7

WATTAGE CALCULATIONS



WATTAGE CALCULATIONS

IMPORTANT! Never exceed the rated capacity of your generator. Serious damage to the generator or appliance could result from an overload.

- 1) "Starting" and "Running" wattage requirements should always be calculated when matching a generator's wattage capacity to the appliance or tool.
- 2) There are two types of electrical appliances that can be powered by your generator:
 - a) Items such as radios, light bulbs, television sets, and microwaves have a "resistive load". Starting wattage and running wattage are the same.
 - b) Items such as refrigerators, air compressors, washer, dryer and hand tools that use an electrical motor have an "inductive load". **Inductive load appliances and tools require approx. 2 to 3 times the listed wattage for "starting" the equipment.** This initial load only lasts for a few seconds on start-up but is important when figuring your total wattage to be used.

Always start your largest electric motor first, and then plug in other items, one at a time.

NOTE: On 120-volt loads the maximum starting wattage should NOT exceed one half of the rated generator wattage.

Wattage Requirement Chart below- This is only a guideline, each appliance or electrical device needs to be checked for its specific operating load.

Application	Wattage Required	
	Running	Peak Starting
Recreation/Camping		
Battery charging	120	120
Portable lighting	200	200
75W Light bulb	75	75
Fan	200	600
Coffee maker	1750	1750
Water pump	500	1500
Yard/Garden		
Hedge trimmer	450	900
Lawn edger	750	1500
Leaf blower	600	1200
Home		
Television	300	300
Radio	50-200	50-200
Computer	150	150
Printer	100	100
Electric range- 6" element	1500	1500
Microwave oven (625W)	625	800
Electric blanket	800	800
Freezer	700	2200
Refridgerator	700	2200
Garage door opener (1/4HP)	550	1100

DETERMINING WATTAGE REQUIREMENTS

Note: Volts X Amps = Watts

Example: 120V X 10 Amps = 1200 Watts

Before operating this generator, list all of the appliances and/or tools that are going to operate at the same time. (Then determine the starting wattage requirements and the running wattage requirements by following the example below:

1) Add the total amount of the running wattage of all appliances and/or tools that will be operated at the same time.

Example 1A:

Lights = 100 Watts (Running)

Television = 300 Watts (Running)

Coffee maker = 1750 Watts (Running)

TOTAL = 2150 Watts (Running)

2) Next add the total amount of the starting wattage of any appliances and/or tools that will start and stop during operation.

Example 1B:

Small Refrigerator = 700 Watts (Running) 2200 Watts (Starting)

Fan = 200 Watts (Running) 600 Watts (Starting)

TOTAL = 900 Watts (Running) 2800 Watts (Starting)

3) The running wattage of examples 1A & 1B totals 3050 watts. The starting wattage totals 2800 watts which is 1900 watts more than the running watts. Take this difference of 1900 starting watts and add to the total running watts of 3050. Therefore:

1900 Starting Watts + 3050 Running Watts = 4950 Total Watts

The generator required to operate the items in example 1A & 1B must have a minimum capacity of at least 4950 starting watts.



MAINTENANCE & STORAGE

MAINTAINING YOUR GENERATOR

Engine Oil Replacement

Engine oil should be replaced after the first 20 hours of operation or after the first month of use, it should be replaced every 100 hours or 6 months after. To replace engine oil:

- 1) Loosen the oil gauge dipstick (A) Fig.8.
- 2) Place an oil pan underneath drain hex. bolt (B), remove hex. bolt (B) and drain oil.
- 3) Once all the oil has completely drained, retighten the hex. bolt (B).

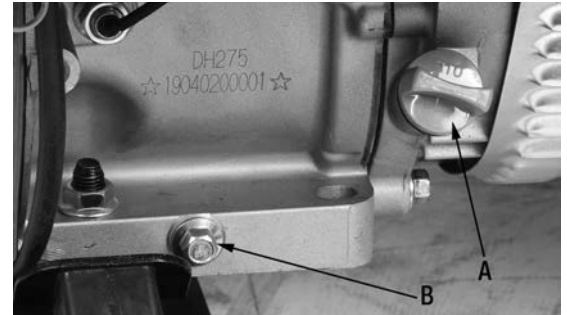

Figure 8

Recommended Engine Oil

It is recommended to use SAE 10W30 4-stroke gasoline engine oil. For cold weather (below -15°C) use SAE 5W30.

- 4) Fill with clean engine oil through the oil gauge dipstick hole, fill then check oil level until the oil level reaches 3/4 up the dipstick or until it reaches the bottom lip of the dipstick hole.

Inspecting, Replacing or Cleaning Spark Plug (F7TC or equivalent)

The spark plug should be checked every 100 hours of operation or every 6 months. To replace or clean spark plug:

- 1) Dismantle the spark plug cap (A) Fig.9 by pulling it off the spark plug (B). Using the supplied spark plug wrench, undo the spark plug by turning it counterclockwise.
- 2) Check to see if there is carbon sediment build-up, if so just remove it. If the carbon sediment is excessive, replace the spark plug.
- 3) Measure the electrodes clearance. See Fig.10. The spark plug electrode clearance should be between 0.7-0.8mm. If the clearance exceeds 0.8mm, replace the spark plug with an LD F7TC or equivalent (NGK BP6ES, Champion N9Y).
- 4) Reinstall spark plug in the reverse order.

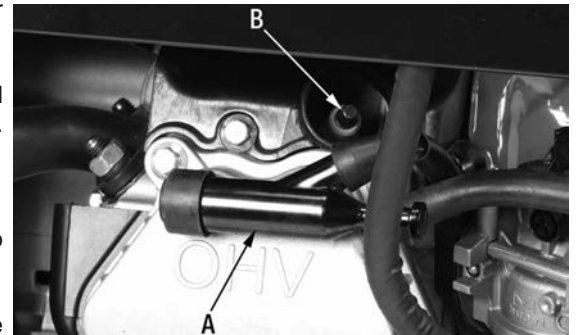

Figure 9

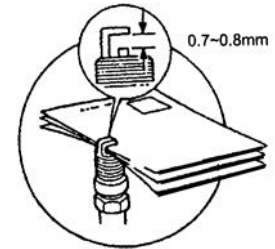

Figure 10

Fuel Filter Maintenance

In order to clean the fuel filter inside the fuel cock, it is necessary to drain all gasoline from the tank and the carburetor, see section "Generator Storage" below for complete instructions.

- 1) Once the tank and carburetor are drained of all gasoline, disconnect the fuel hose (A) Fig.11 from the fuel cock and then dismantle the fuel cock nut (B) from the tank.
- 2) Remove the fuel cock from the tank to expose the fuel filter (C). Clean the fuel filter.
- 3) Reinstall all parts in the reverse order.

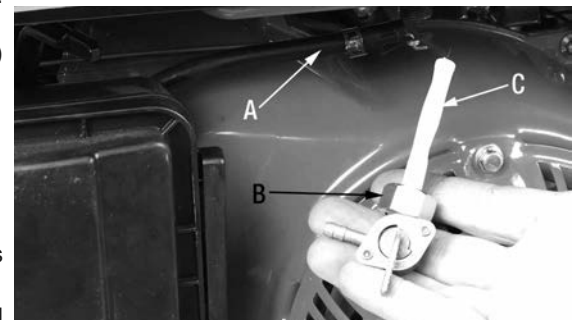

Figure 11

GENERATOR STORAGE

If you plan on storing your generator for an extended period of time, the following steps should be followed:

- 1) Add fuel stabilizer to fuel tank to minimize the formation of fuel gum deposits during storage.
- 2) Run engine at least 5 minutes after adding stabilizer to allow it to enter the fuel system.
NOTE: If a fuel stabilizer is not used, all gasoline must be drained from the tank and carburetor to prevent gum deposits from forming on these parts and causing possible malfunction of the engine. To drain gasoline;
- 3) Turn fuel shut-off valve (A) Fig.12 to the "OFF" position.
- 4) Disconnect the fuel hose (B) from the fuel cock.
- 5) Turn fuel shut-off valve to the "ON" position and drain fuel from tank. Pivot the fuel cock outwards to simplify the task as shown in Fig.12.
- 6) Remove drain hex. bolt (D) from the carburetor (C) and drain the rest of the fuel found inside the carburetor and hose.
- 7) Reposition the carburetor drain hex. bolt and fuel cock hose once the fuel is completely drained.
- 8) Drain engine oil from engine as described in "Engine Oil Replacement".
- 9) Pull the recoil starter handle gently until resistance is felt.

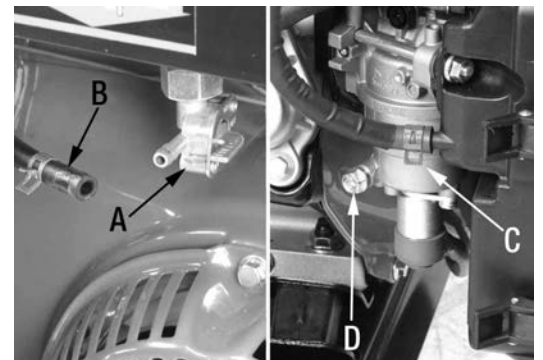

Figure 12

TROUBLESHOOTING



PROBLEM	CAUSE	CORRECTION
Engine will not start	<ol style="list-style-type: none"> 1. Low on fuel or oil. 2. Ignition switch in "Off" position. 3. Faulty spark plug. 4. Choke in wrong position. 5. Fuel shut-off valve is closed. 6. Unit loaded during start-up. 7. Spark plug wire loose. 	<ol style="list-style-type: none"> 1. Add fuel or oil. 2. Turn to "ON" position. 3. Replace spark plug. 4. Adjust choke accordingly. 5. Open fuel shut-off valve. 6. Remove load from unit. 7. Attach wire to spark plug.
Engine is running but no AC output	<ol style="list-style-type: none"> 1. Faulty receptacle. 2. Circuit breaker tripped. 3. Defective capacitor. 4. Faulty power cord. 	<ol style="list-style-type: none"> 1. Have Service Center replace. 2. Reset breaker. 3. Have Service Center replace capacitor. 4. Repair or replace cord.
Repeated circuit breaker tripping	<ol style="list-style-type: none"> 1. Overload. 2. Faulty cords or equipment. 	<ol style="list-style-type: none"> 1. Reduce load. 2. Check for damaged, bare, or frayed wires on equipment. Replace.
Generator overheating	<ol style="list-style-type: none"> 1. Generator overloaded. 2. Insufficient ventilation. 	<ol style="list-style-type: none"> 1. Reduce load. 2. Move to adequate supply of fresh air.
Engine runs well but gets bogged down when loads are connected	<ol style="list-style-type: none"> 1. Electrical short in connected item. 2. Overloaded. 	<ol style="list-style-type: none"> 1. Disconnect shorted load. 2. Reduce load.



IF YOU ARE EXPERIENCING PROBLEMS, DO NOT RETURN TO THE RETAILER, CALL THIS TOLL-FREE NUMBER FOR SERVICE INFORMATION

1-877-636-4214



OPERATING YOUR GENERATOR IN HIGH ALTITUDE (2,000 FT - 7000 FT ABOVE SEA LEVEL)

High Altitude Operation Above 2,000 feet

WARNING! Operating this engine above 2,000 feet above sea level without the proper High Altitude Parts Kit installed may increase the engine's emissions and decrease fuel economy and performance.

WARNING! TO PREVENT SERIOUS INJURY FROM FIRE:

- 1) Follow instructions in a well-ventilated area away from ignition sources.
- 2) If the engine is hot from use, shut the engine off and wait for it to cool before proceeding.
- 3) Do not smoke.

NOTE: Warranty is void if necessary adjustments are not made for high altitude use above 2,000 feet above sea level.

At high altitudes, the engine's carburetor, governor (if so equipped), and any other parts that control the fuel-air ratio will need to be adjusted by a qualified mechanic to allow efficient high-altitude use and to prevent damage to the engine and any other devices used with this product. The fuel system on this engine may be influenced by operation at higher altitudes. Proper operation can be ensured by installing an available High Altitude Parts Kit listed below at altitudes higher than 2,000 ft. above sea level.

WARNING! At elevations above 7,000 ft, the engine may experience decreased performance, even with the proper main jet from the proper High Altitude Parts Kit.

The High Altitude Parts Kit (part order number 73-65021800) should be installed by a qualified mechanic.

How to install the appropriate High Altitude Parts Kit:

1. Turn off the engine, let it cool down completely.
2. Close the fuel valve.
3. Remove the existing carburetor assembly.
4. Install the high altitude parts kit into the carburetor assembly:
 - a. Remove 2 bolts (A), 2 spring washers (B) and fuel solenoid (C).
 - b. Remove solenoid seal (D), bolt (E), bolt seal (F) and fuel cup (G).
 - c. Remove main jet (H) and place into a clean bag for future use in lower altitudes.
 - d. Replace the main jet (H) with the correct replacement main jet after determining the operating altitude.

- Jet 1A (2000ft to 3000ft)
- Jet 2A (3000ft to 5000ft)
- Jet 3A (5000ft to 6000ft)
- Jet 4A (6000ft to 7000ft)

- e. The fuel cup seal and bolt seal may be damaged during removal and should be replaced with the new ones from the High Altitude Parts Kit. Replace the fuel cup seal (I, 6A) and bolt seal (F, 5A) provided in the kit.
- f. Reassemble all parts in the reverse order.

5. Install the new carburetor assembly with high altitude parts installed.
6. Tag or place a label on the generator stating the high altitude parts were installed and to reservice before operating the product in lower altitude environments.

CAUTION! Carburetor fuel cup may have gas in it which will leak upon removing the bolt.

7. Wipe up any spilled fuel and allow excess to evaporate before starting engine. To prevent FIRE, do not start the engine while the smell of fuel hangs in the air.

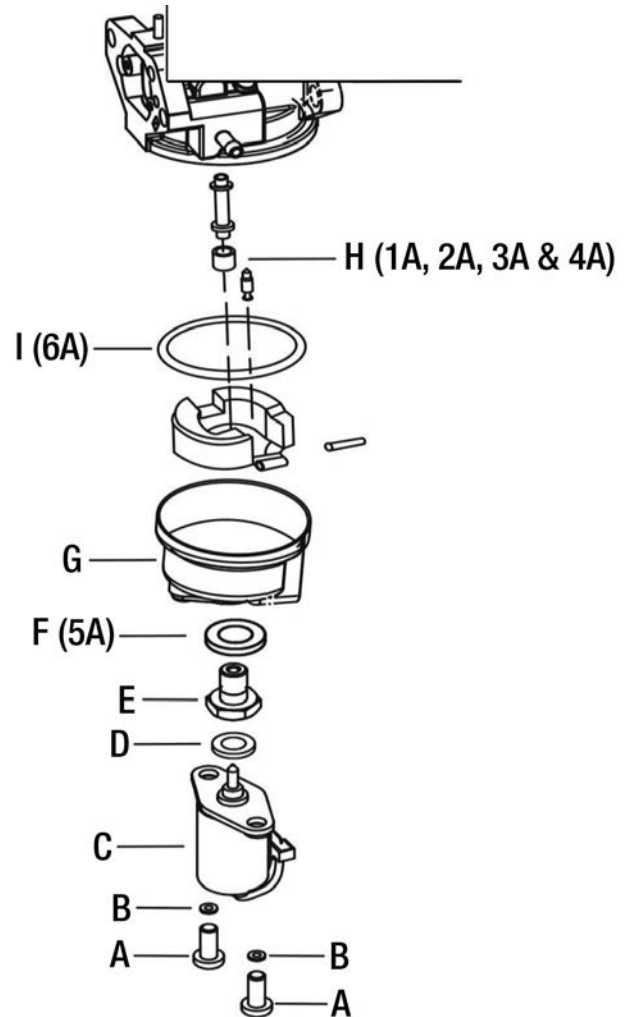

No.	Description	Qty
1A	Main jet (2,000 to 3,000 ft.)	1
2A	Main jet (3,000 to 5,000 ft.)	1
3A	Main jet (5,000 to 6,000 ft.)	1
4A	Main jet (6,000 to 7,000 ft.)	1
5A	Bolt seal	1
6A	Fuel cup seal	1

PARTS DIAGRAM & PARTS LISTS

Refer to the Parts section of the King Canada web site for the most updated parts diagram and parts list.

No.	Order#	Description	Qty
180	73-65021800	High altitude parts kit	1