

Maximum Weight Capacity 220Kgs/ 485 Lbs

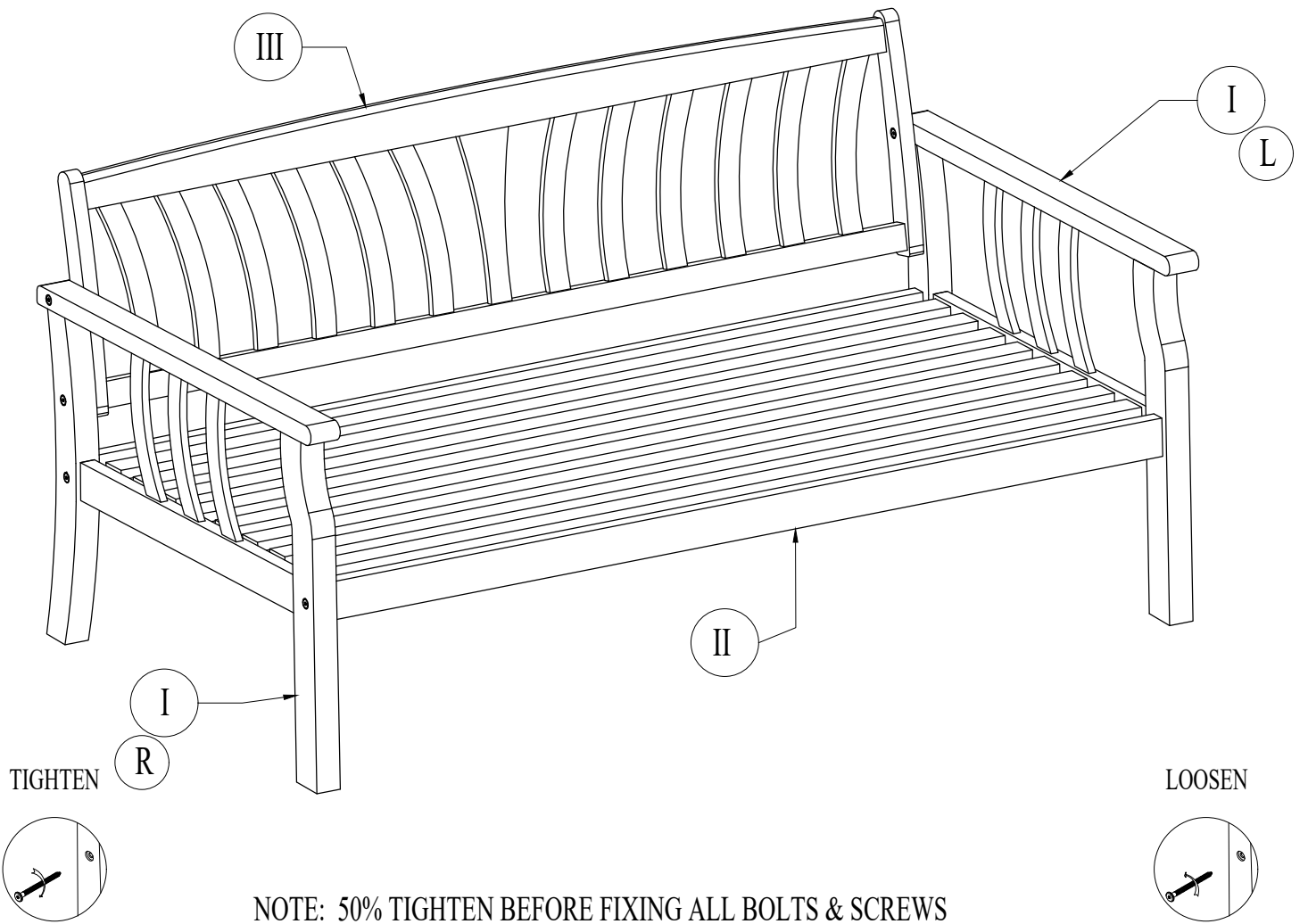



### COMPONENTS LIST

<p>I</p> <p>R</p> <p>L</p> <p>Q'TY: 2 (Right &amp; Left)</p>	<p>II</p> <p>Q'TY: 1</p>	<p>III</p> <p>Q'TY: 1</p>
	<p>IV</p> <p>Q'TY: 2</p>	<p>V</p> <p>Q'TY: 2</p>

### HARDWARE LIST

A		6	Screw 7x 90	B		2	Bolt 8x 60
C		2	Sleeve nut 8x 18	D		2	Allen Key



## Step 2

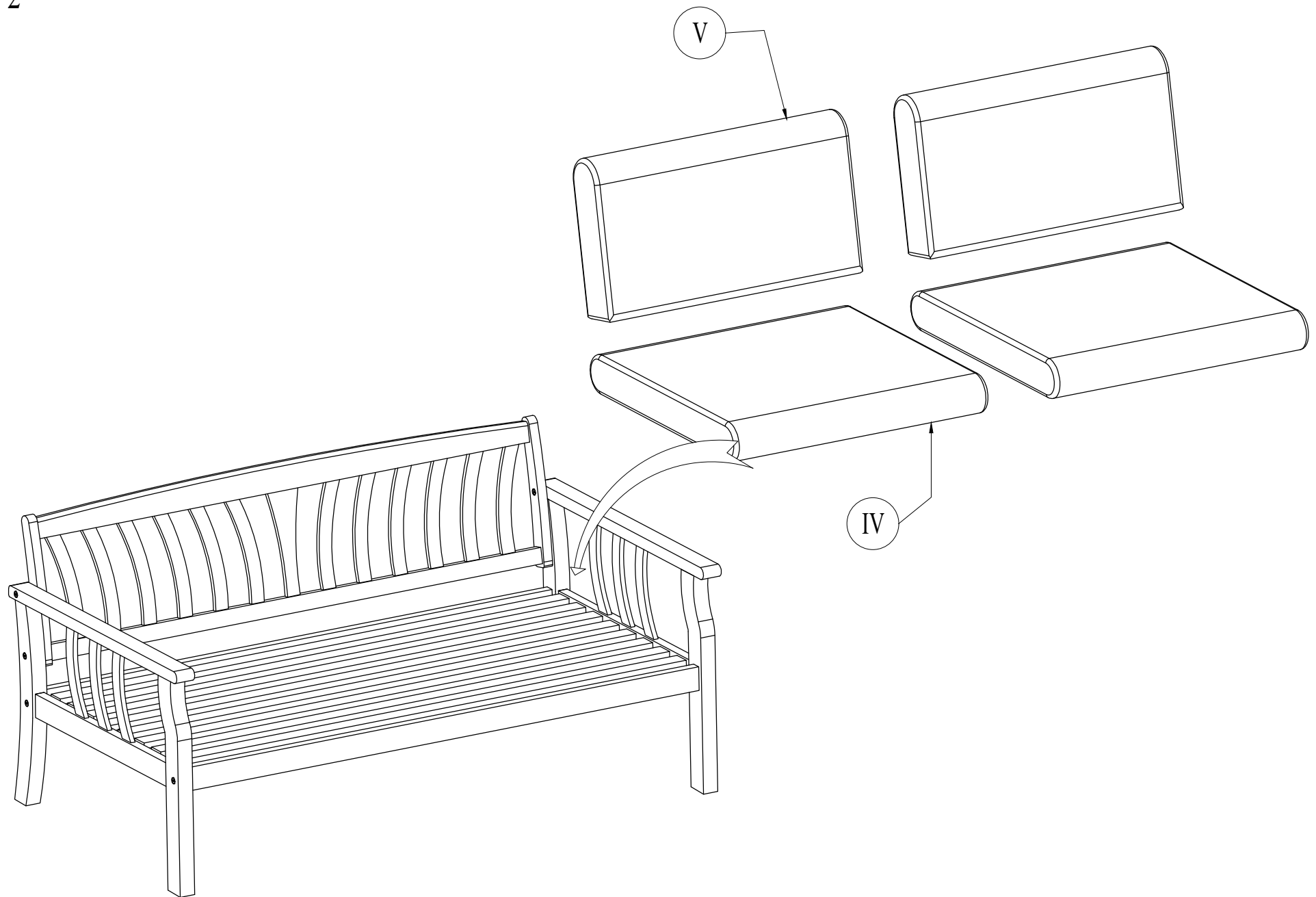

Đặt nệm (IV) , (V) vào mê ngồi và lưng tựa

Step 3

