



ASSEMBLY GUIDE
GUIDE DE MONTAGE
GUÍA DE MONTAJE

CLASSIC
CLASSIQUE
CLÁSICO

8X12 KEYHOLE GARDEN BED

JARDIN DE TROU DE SERRURE 8X12
JARDÍN DE OJO DE CERRADURA 8X12

VT17125

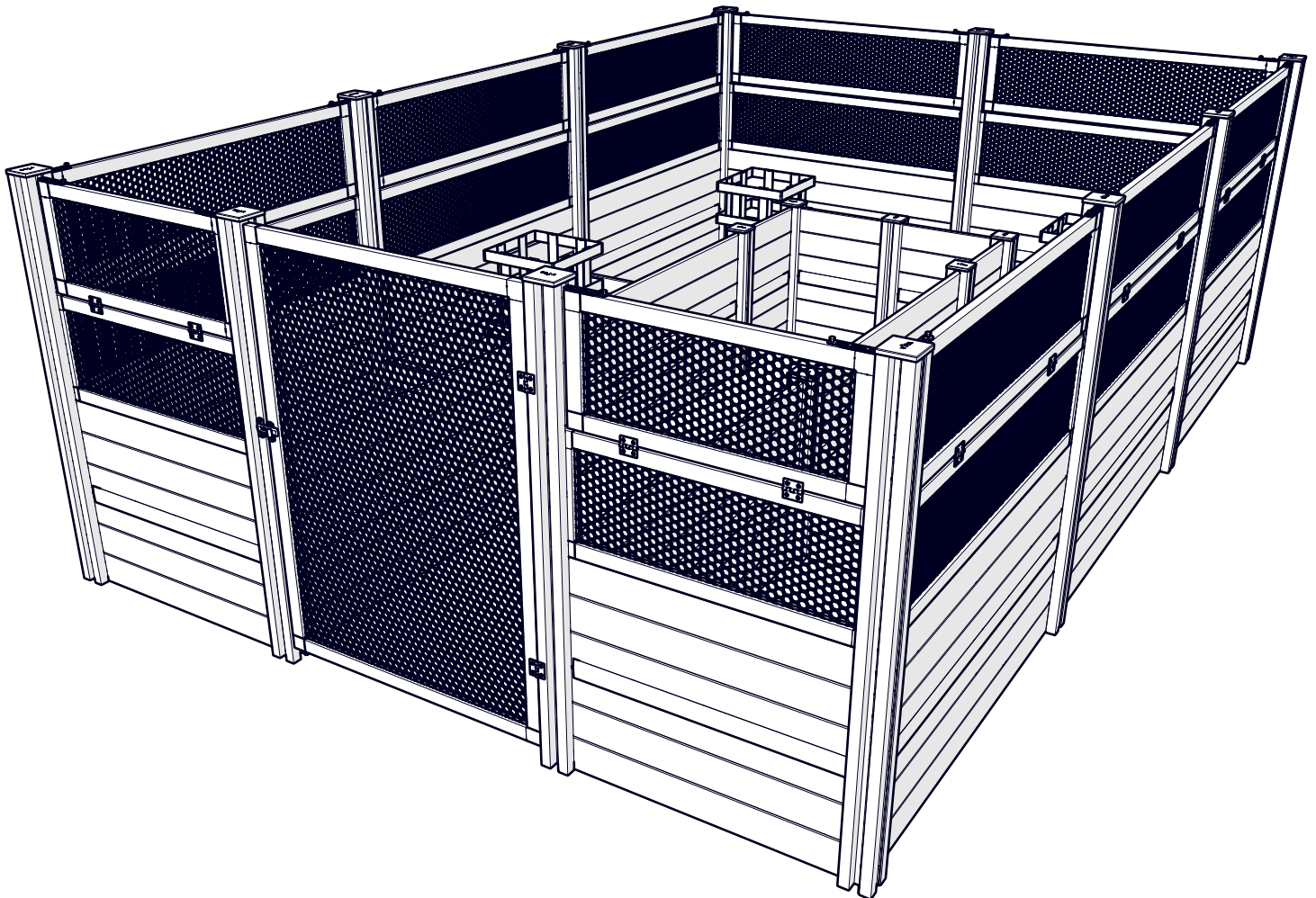

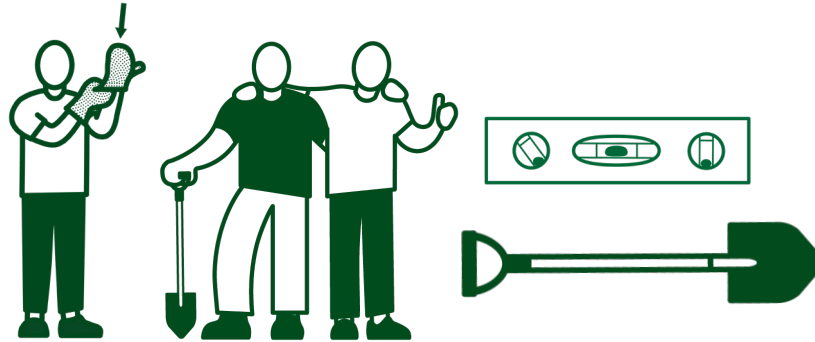

REQUIRED TOOLS AND MATERIALS (NOT INCLUDED)
OUTILS ET MATÉRIAUX REQUIS (NON INCLUS)
HERRAMIENTAS Y MATERIALES REQUERIDOS (NO INCLUIDOS)

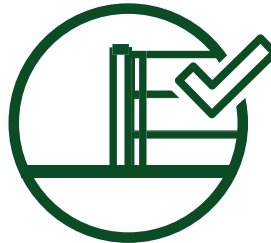

HELLO@WEAREVITA.COM



VISIT WWW.WEAREVITA.COM
CLICK 'CHAT'



1-800-282-9346
MONDAY - FRIDAY | 8AM - 5PM EST



PRODUCT DIMENSIONS

DIMENSIONS DU PRODUIT

DIMENSIONES DEL PRODUCTO

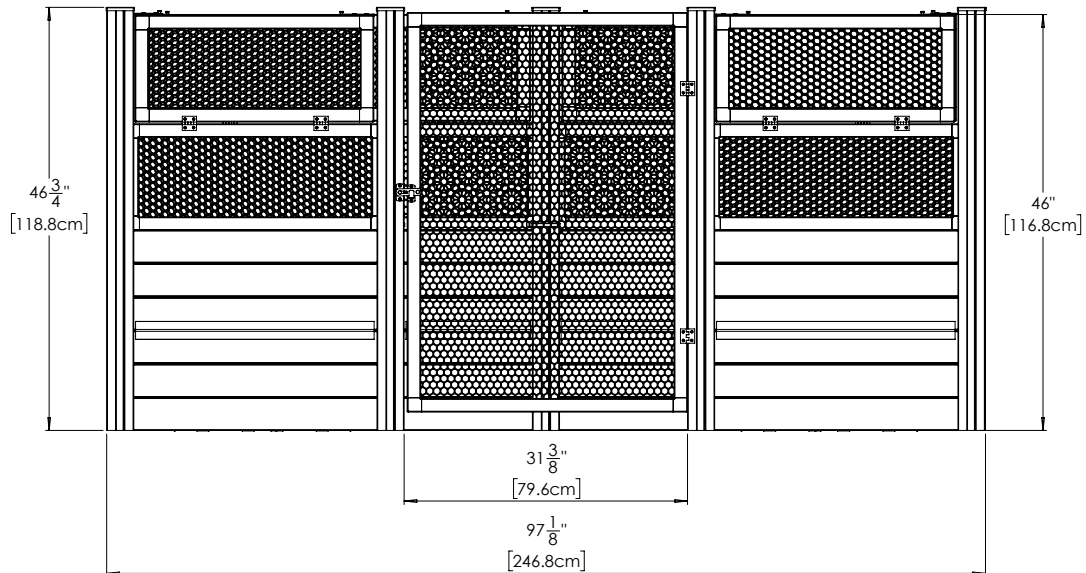
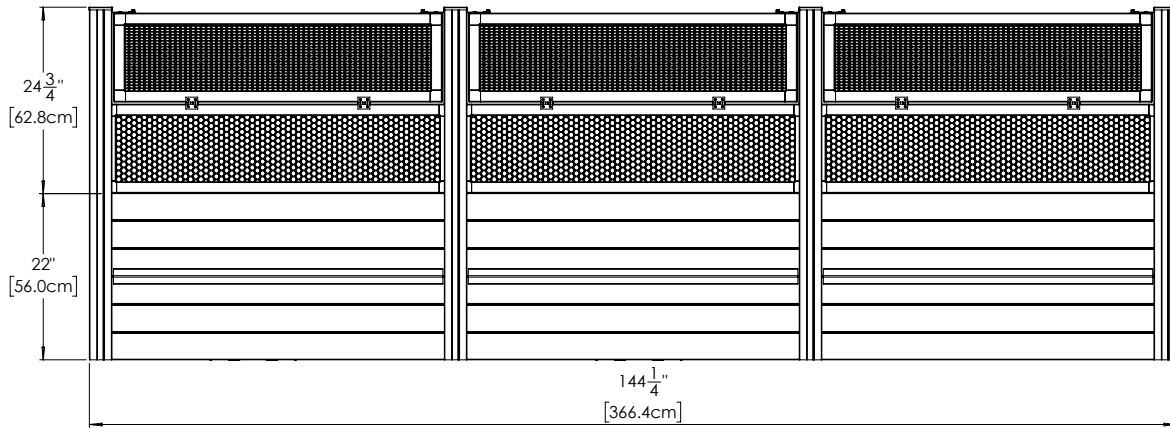
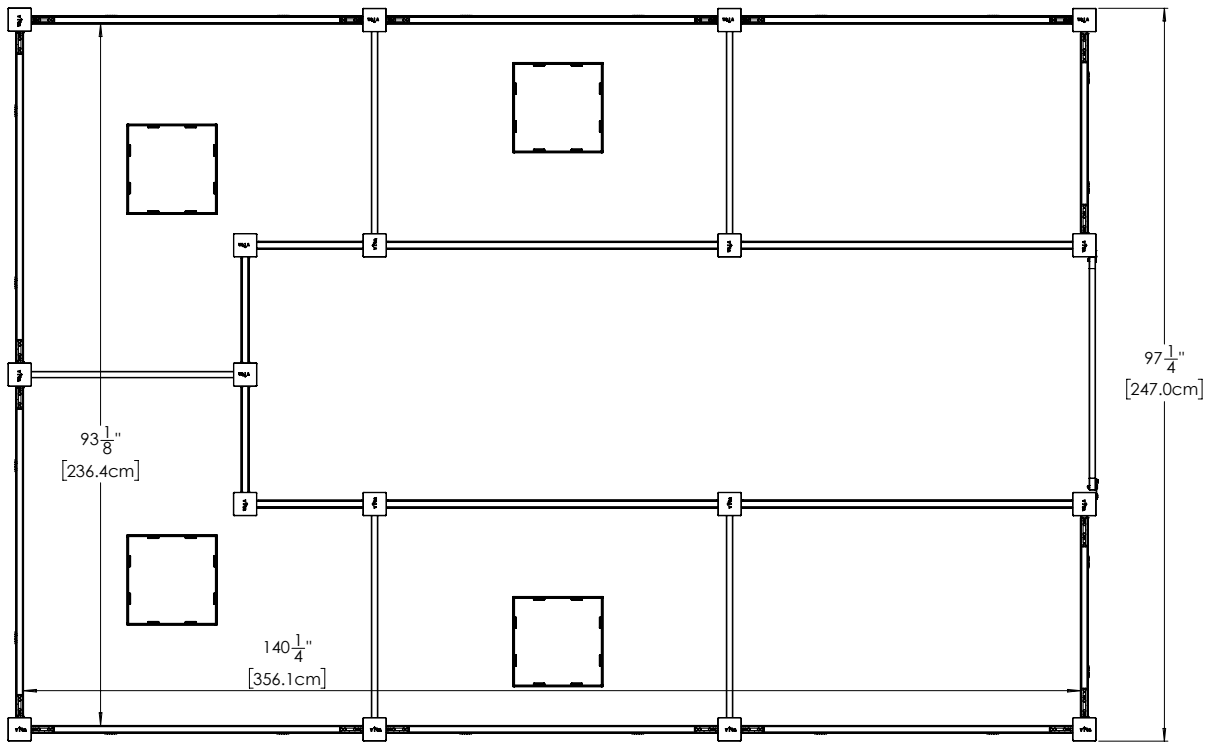

PARTS LIST

LISTE DES PIÈCES
LISTADO DE PIEZAS

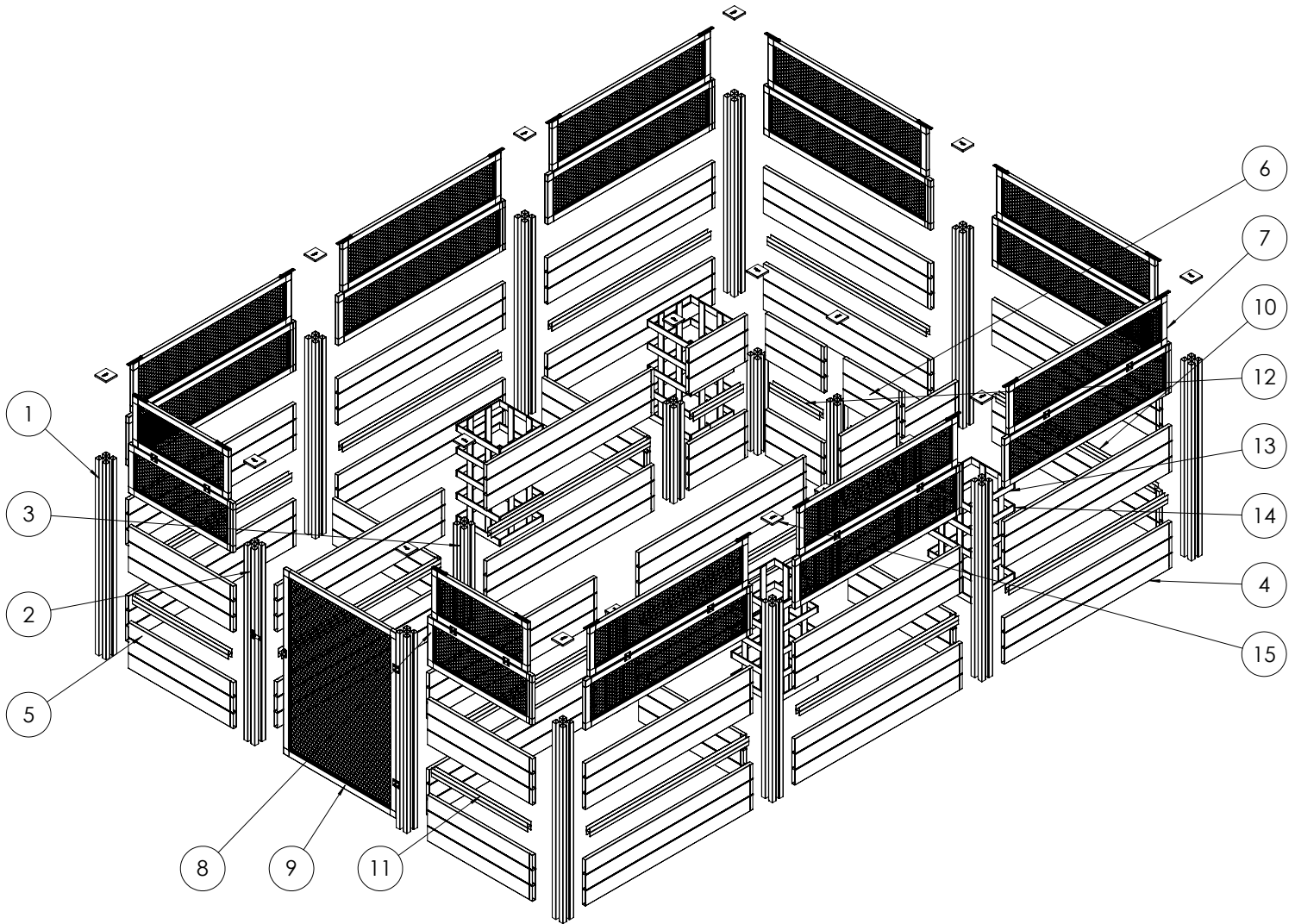

Item No.	Part Number	Description	Dimensions	Qty.
1	11166	Long Post	46 5/8" (118.4cm)	9
2	11167	Gate Post	46 5/8" (118.4cm)	1
3	11169	Short Post	22 3/4" (57.8cm)	7
4	11170	Long Board	46" (116.8cm)	24
5	11171	Medium Board	28 7/8" (73.4cm)	9
6	11172	Short Board	16" (41cm)	8
7	11173	Long Fence Panel	46" (116.7cm)	8
8	11174	Short Fence Panel	28 3/4" (73cm)	2
9	11175	Door	34 1/8" x 46 1/2" (86.7cm x 118.1cm)	1
10	11185	Long H-Channel	43 3/4" (111.1cm)	12
11	11184	Medium H-Channel	26 3/8" (67cm)	2
12	11186	Short H-Channel	13 3/4" (34.9cm)	4
13	60008	Basket Panel	23" (58.4cm)	16
14	60009	Basket Bracket	1" x 1" (2.5cm x 2.5cm)	80
15	10766	Post Cap	3" x 3" (7.6cm x 7.6cm)	18

COMPLETELY UNPACK AND TAKE INVENTORY OF PARTS BEFORE BEGINNING

DEBALLEZ COMPLETEMENT ET FAITES L'INVENTAIRE DES PIECES AVANT DE COMMENCER

ANTES DE COMENZAR, DESEMBALE COMPLETAMENTE EL PRODUCTO Y REALICE UN INVENTARIO DE LAS PIEZAS

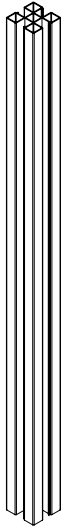

1 9X



2 1X

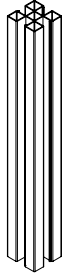

3 7X

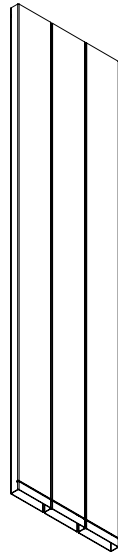

4 24X

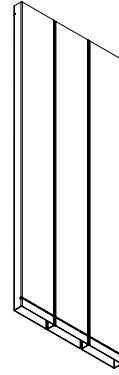

5 9X

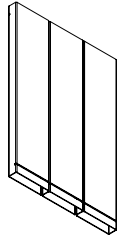

6 8X

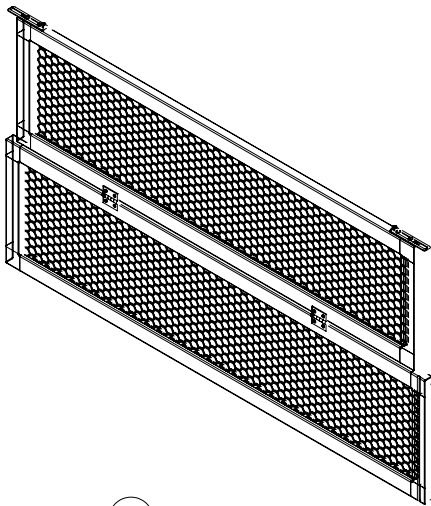

7 8X

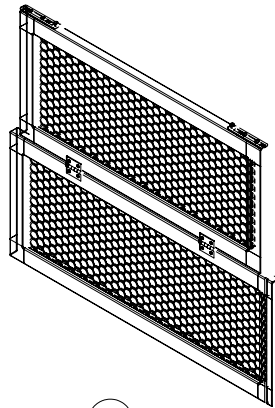

8 2X

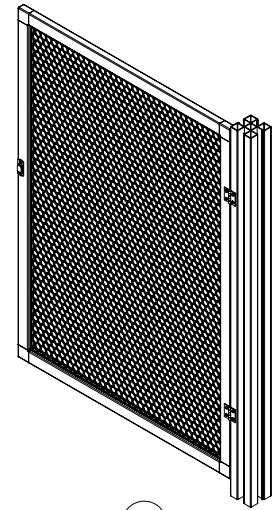

9 1X

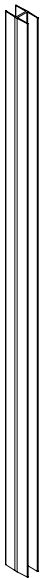

10 12X

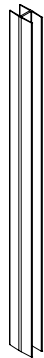

11 2X

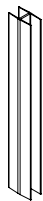

12 4X

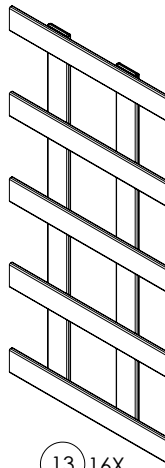

13 16X

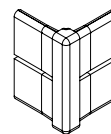

14 80X



15 18X

FOR THE GATE AND MESH PANELS TO OPERATE CORRECTLY, IT IS CRITICAL THAT YOUR GARDEN IS INSTALLED OVER A VERY LEVEL SURFACE. SOME SUGGESTED IDEAS FOR PREPARING THE SURFACE ARE AS FOLLOWS:

POUR QUE LA PORTE ET LE PANNEAU GRILLAGÉ FONCTIONNENT CORRECTEMENT, IL EST IMPORTANT QUE VOTRE JARDIN SOIT INSTALLÉ SUR UNE SURFACE PARFAITEMENT PLANE. VOICI QUELQUES SUGGESTIONS POUR PRÉPARER LA SURFACE.

PARA QUE LA PUERTA Y LOS PANELES DE MALLA FUNCIONEN CORRECTAMENTE, ES FUNDAMENTAL QUE INSTALE SU JARDÍN SOBRE UN SUELO BIEN NIVELADO. AQUÍ LE SUGERIMOS ALGUNAS IDEAS PARA PREPARAR LA SUPERFICIE.

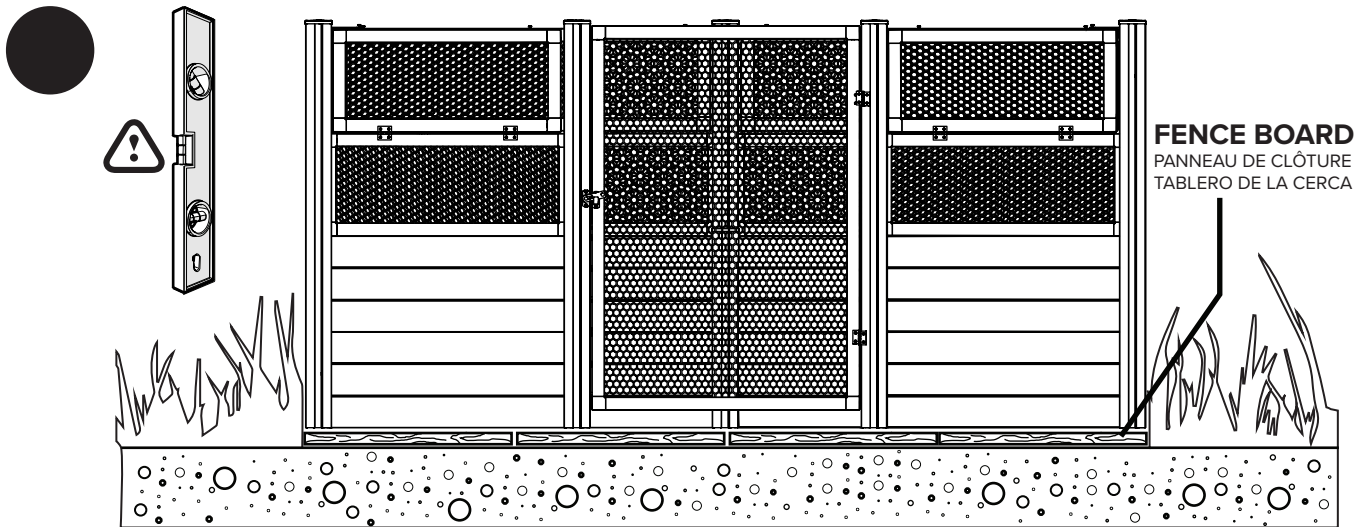

CONSIDER PURCHASING SOME FENCE BOARDS TO LAY ON THE GROUND, AND DIRECTLY UNDER THE EDGES OF THE GARDEN.

ENVISAGEZ D'ACHETER QUELQUES PLANCHES DE PALISSADE À POSER SUR LE SOL, ET DIRECTEMENT SOUS LES BORDS DU JARDIN.

CONSIDERE LA POSIBILIDAD DE COMPRAR ALGUNAS TABLAS PARA COLOCAR SOBRE EL SUELO Y DEBAJO DE LOS BORDES DEL JARDÍN.

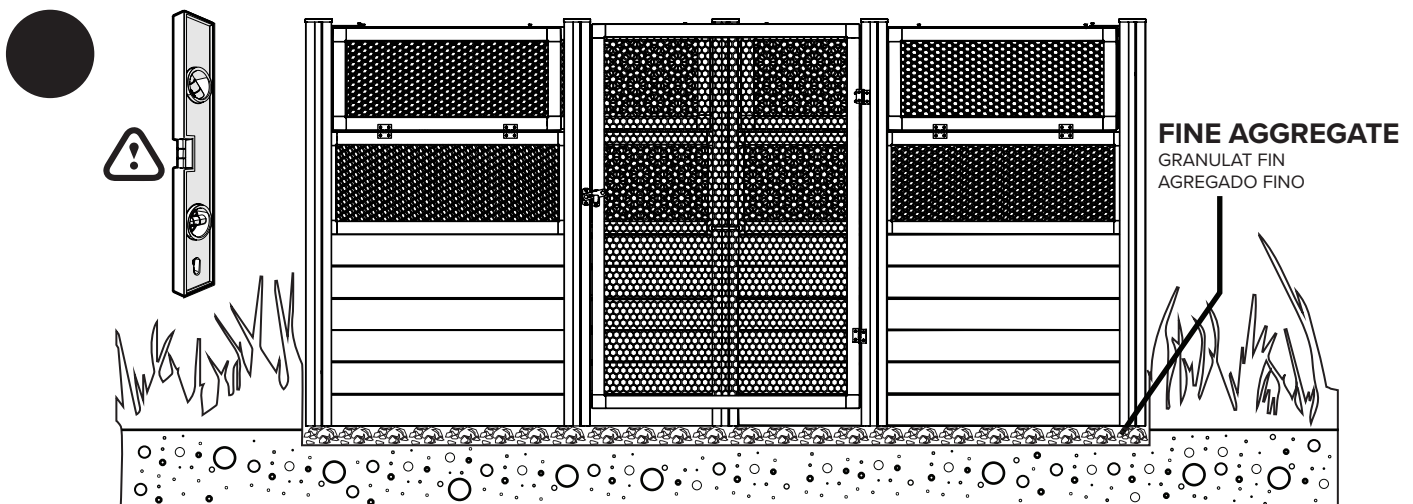

CUT OUT THE GROUND AND INSTALL SOME FINE AGGREGATE OR SCREENINGS USED FOR UNDER PATIO STONES TO CREATE A LEVEL SURFACE FOR YOUR GARDEN.

CREUSEZ LÉGÈREMENT LE SOL ET INSTALLEZ DES GRAVIERS OU DU GRAVILLON QU'ON PLACE SOUS LES PIERRES D'UN PATIO POUR CRÉER UNE SURFACE PARFAITEMENT PLANE ET NIVELÉE POUR VOTRE JARDIN.

RETIRE EL SUELO Y COLOQUE AGÚN AGREGADO FINO O GRAVA DE LA QUE SUELE UTILIZARSE DEBAJO DE LAS PIEDRAS DEL PATIO PARA CREAR UNA SUPERFICIE NIVELADA EN SU JARDÍN.

INSTALL THE GATE

INSTALLEZ LE PORTAIL
INSTALAR LA PUERTA

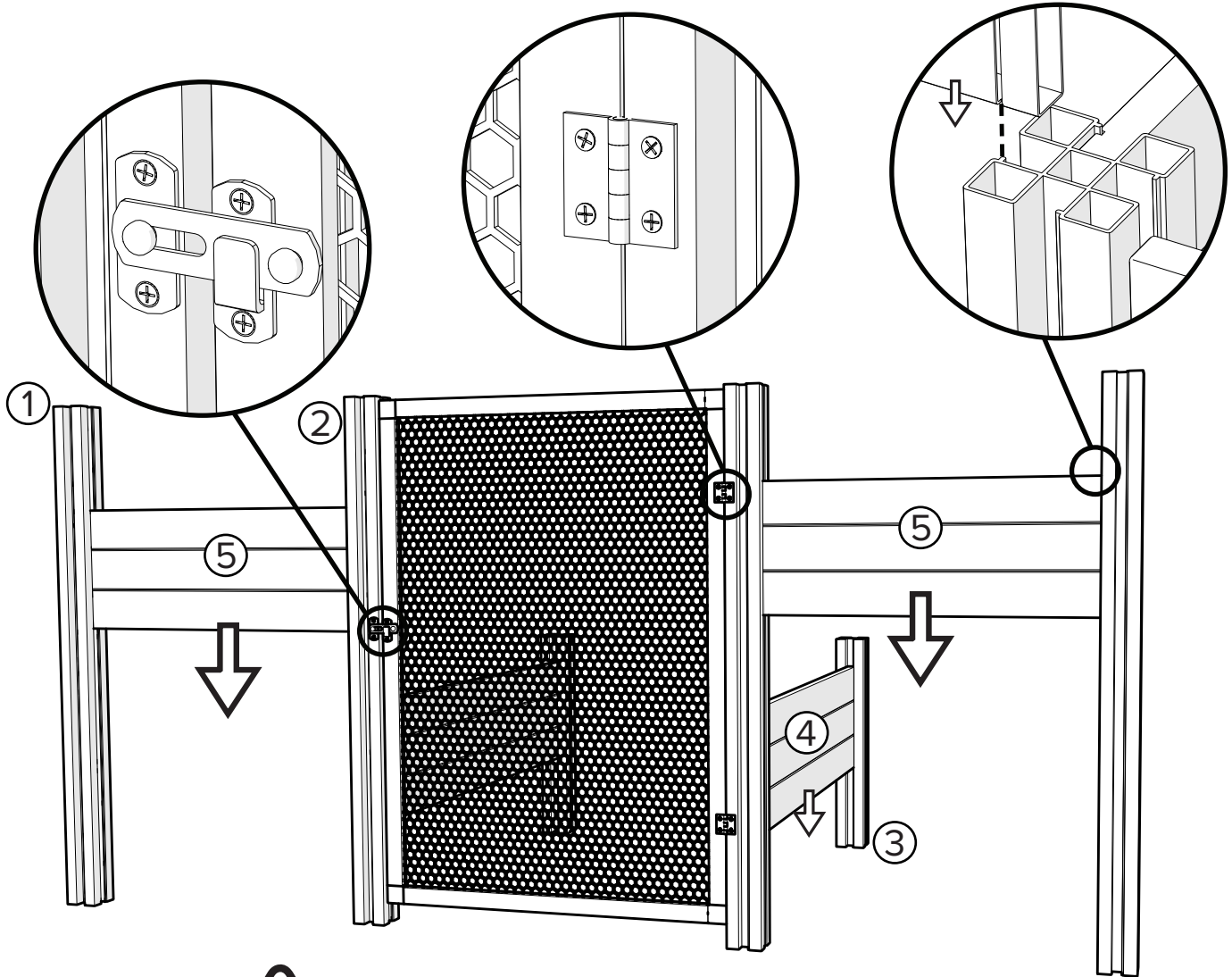
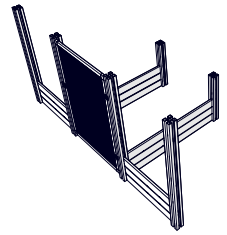
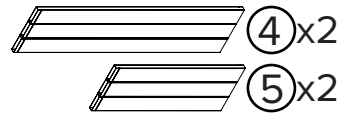
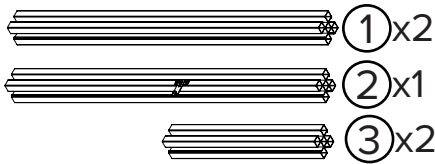
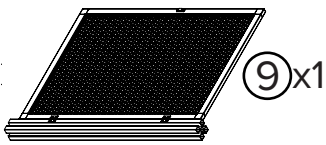

THE FRONT GATE POSTS MUST BE LEVEL, TO ENSURE THE GATE WORKS PROPERLY. PLEASE ADJUST BY EITHER ADDING OR REMOVING SOIL TO LEVEL THE POSTS.

LES POTEAUX DE LA PORTE CENTRALE DOIVENT ÊTRE AU MÊME NIVEAU, POUR PERMETTRE À LA PORTE DE FONCTIONNER CONVENABLEMENT. VEUILLEZ DONC AJUSTER EN AJOUTANT OU EN RETIRANT DU TERREAU POUR METTRE LES POTEAUX À NIVEAU.

LOS POSTES DE LA PUERTA FRONTAL DEBEN ESTAR NIVELADOS PARA GARANTIZAR QUE ESTA FUNCIONE ADECUADAMENTE. AJUSTE EL NIVEL DE LOS POSTES AGREGANDO O QUITANDO TIERRA.

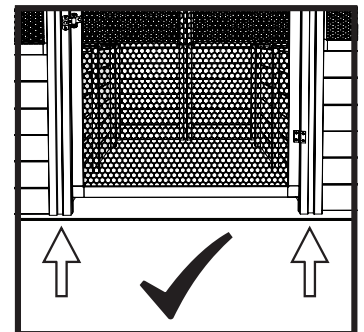
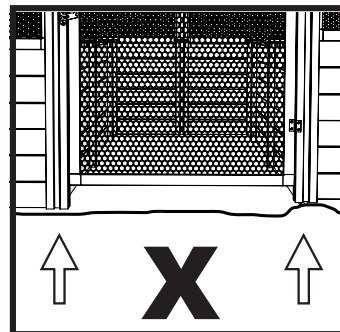

2 ASSEMBLE THE GARDEN PERIMETER

ASSEMBLEZ LE PÉRIMÈTRE DE CEINTURE DU JARDIN
ARME EL PERÍMETRO DEL JARDÍN

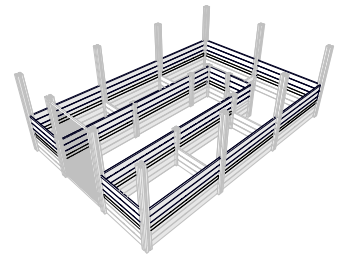
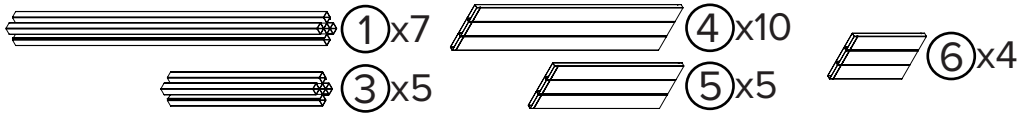

2A

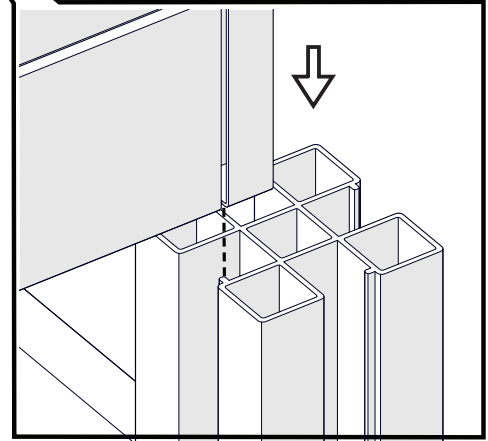
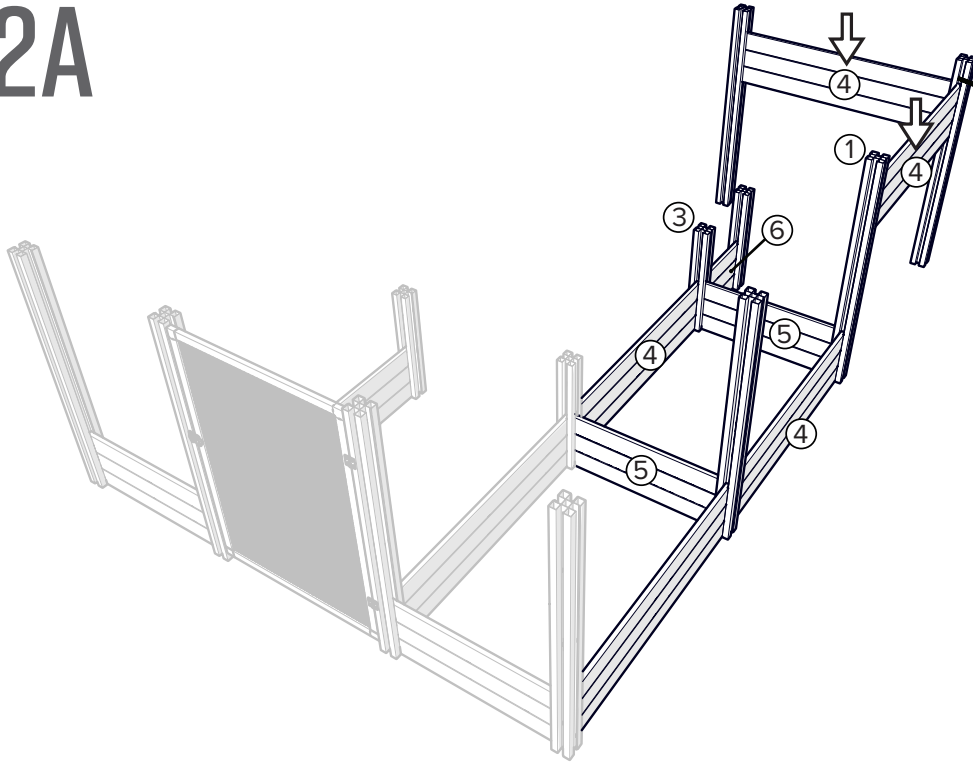

2B

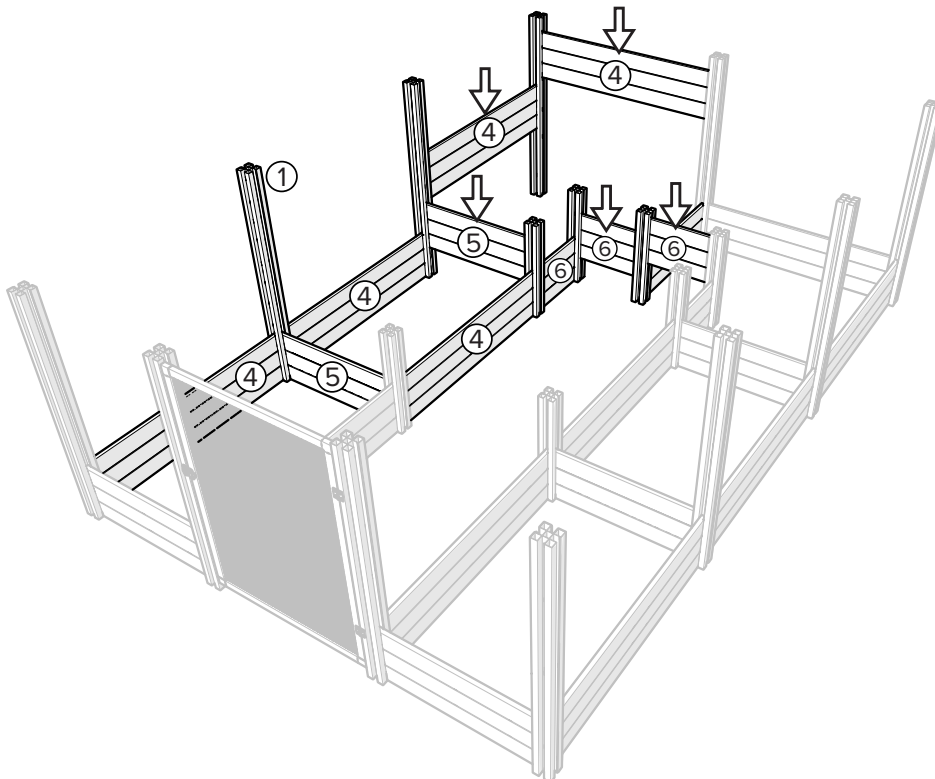

3 SLIDE DOWN THE H-CHANNELS AND TOP BOARDS

FAITES GLISSER VERS LE BAS LES MONTANTS EN H ET LES PLANCHES DU HAUT
DESLICE HACIA ABAJO LOS PERFILES EN H Y LAS TABLAS SUP

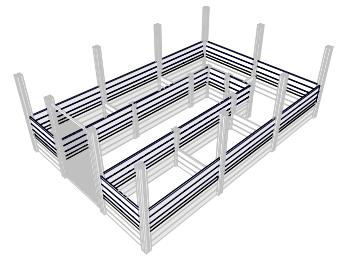
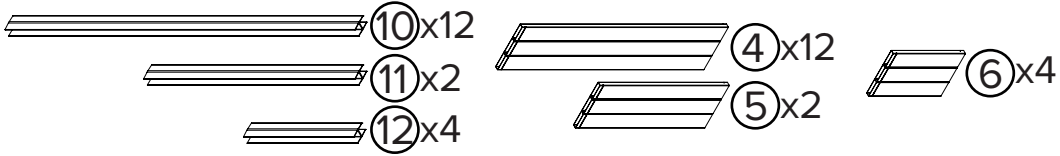

3A

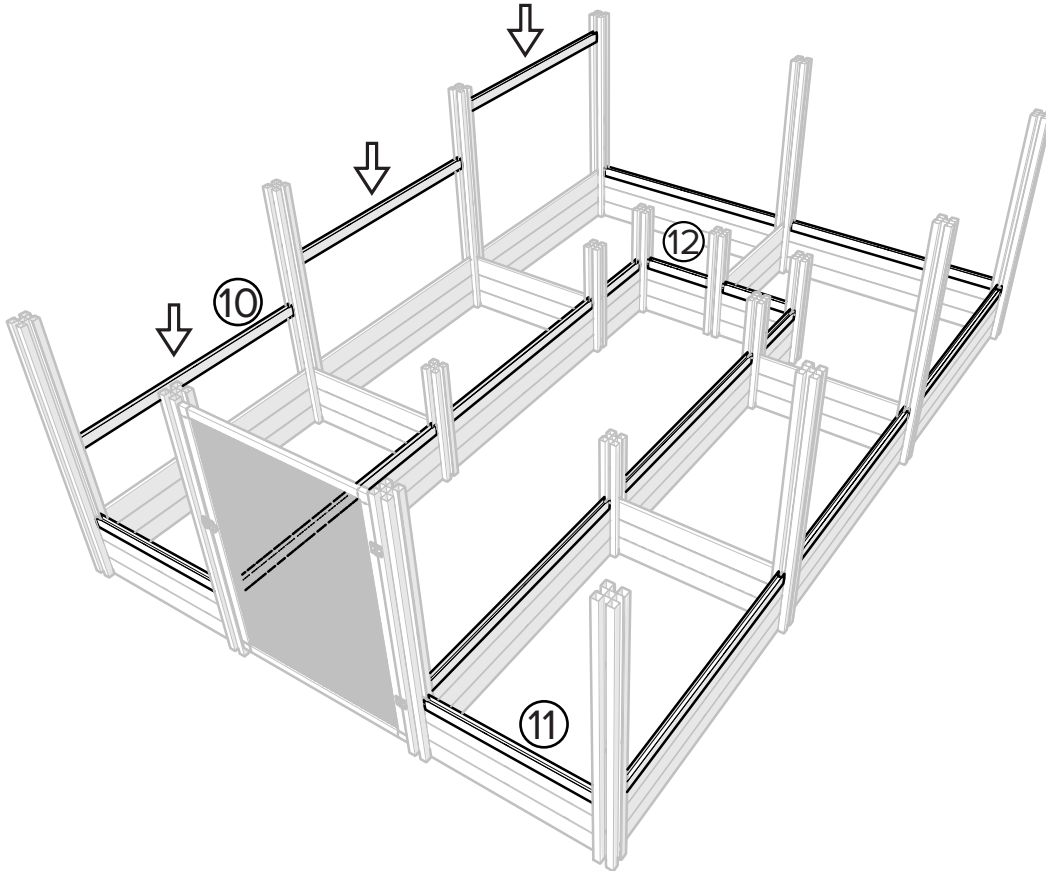

3B

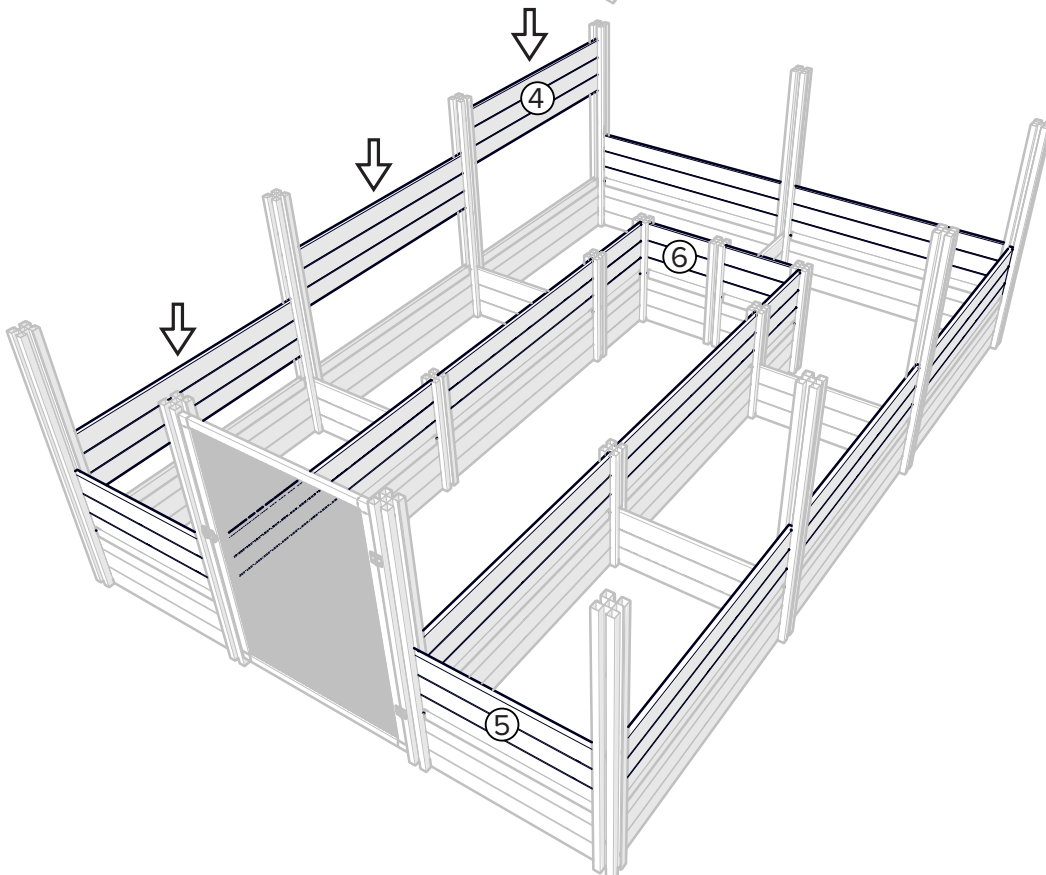

4 SLIDE DOWN THE FENCE BOARDS AND THE POST CAPS

FAITES GLISSER VERS LE BAS LES PLANCHES DE CLÔTURE ET LES EMBOUTS DE POTEAUX
DESLOCIE HACIA ABAJO LOS PANELES DE LA CERCA Y COLOQUE LAS TAPAS DE LOS POSTES

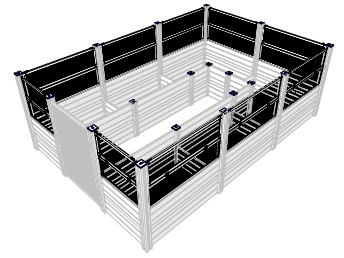
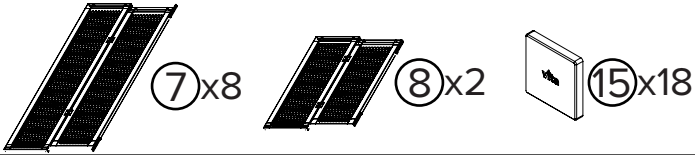

4A

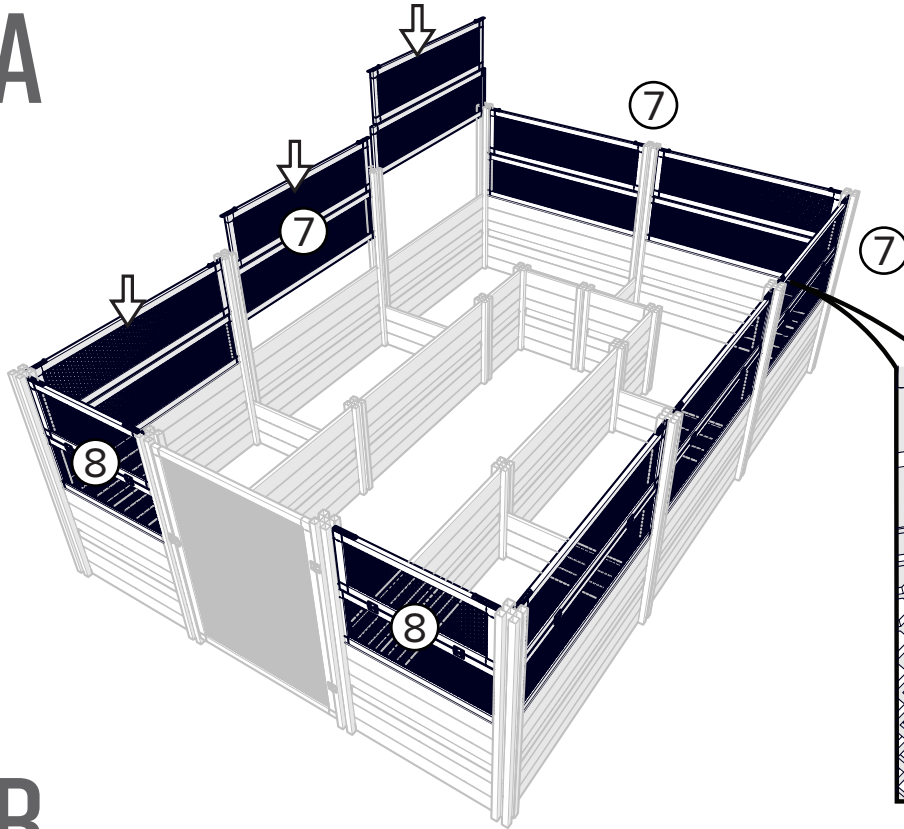

4B

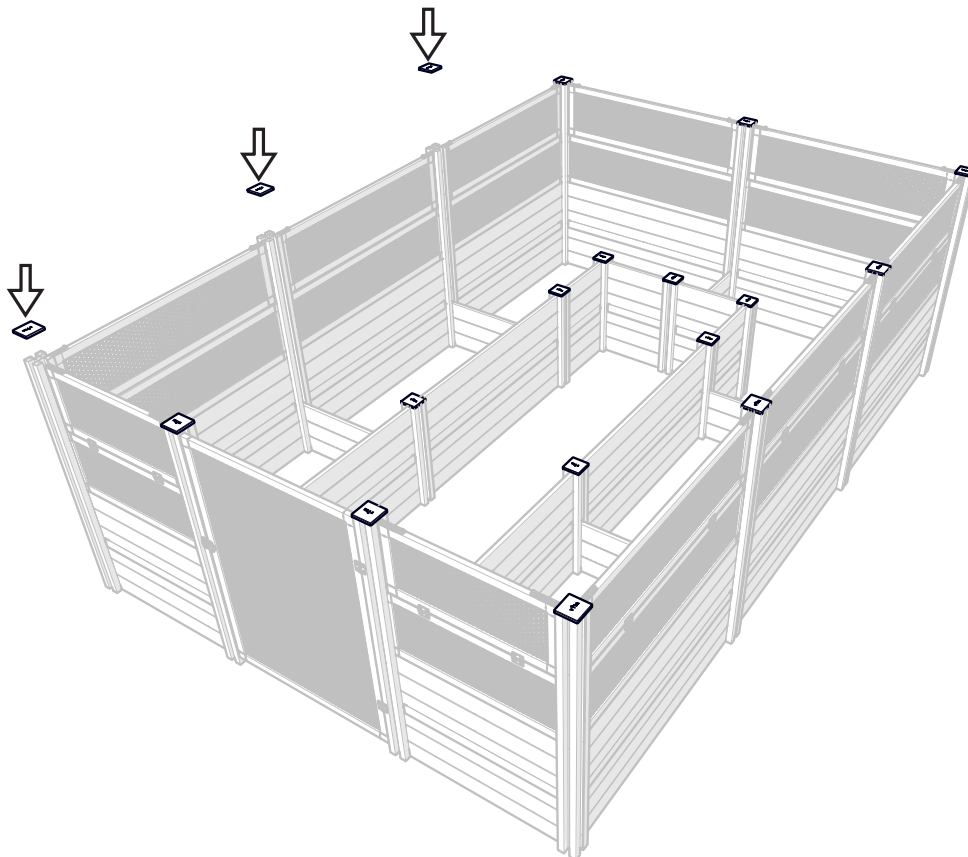

5 ASSEMBLE AND PLACE THE BASKETS

ASSEMBLEZ ET METTEZ EN PLACE LES PANIERS
ARME Y COLOQUE LAS CES

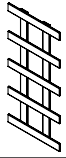

13x16



14x80

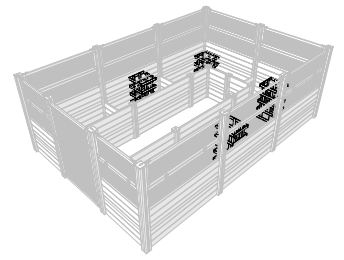

5A

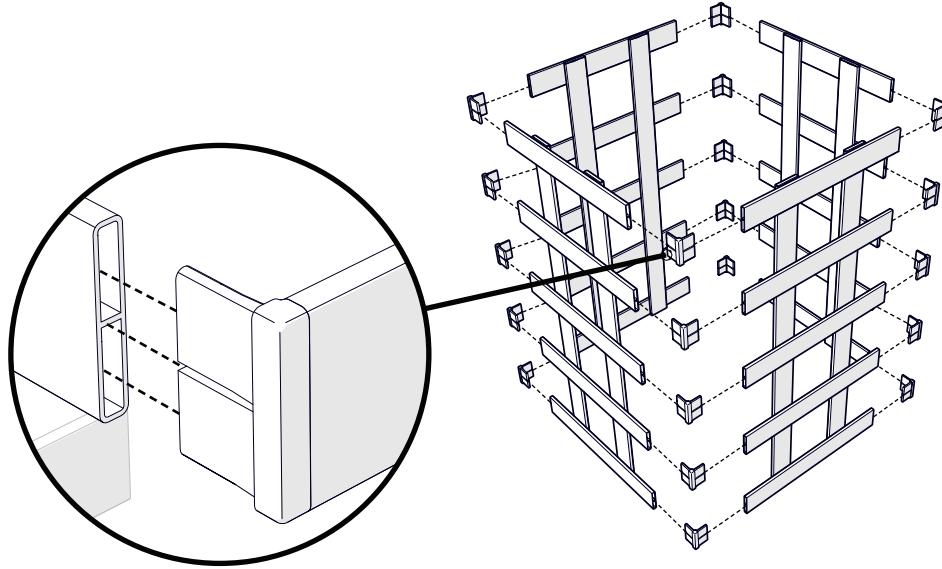

5B

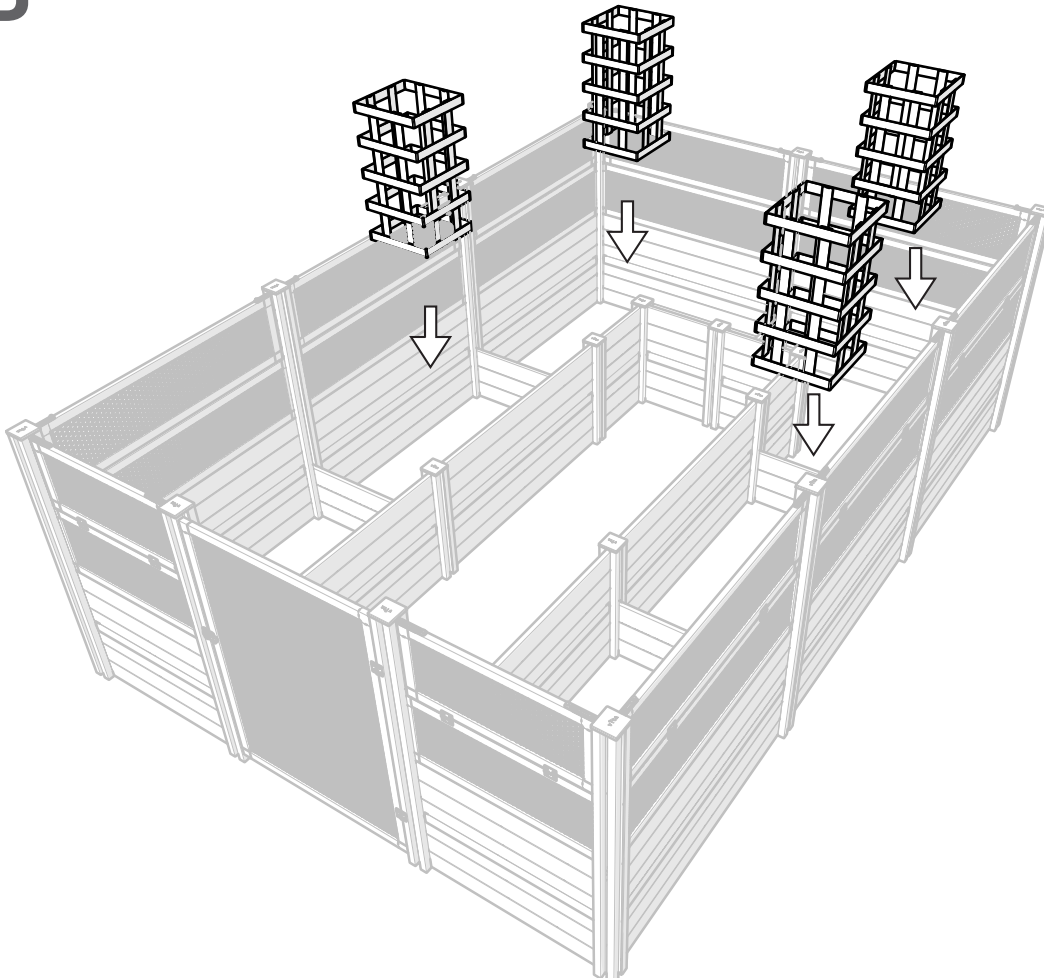

A.

FILL WITH SOIL!
 MIT ERDE FÜLLEN!
 RIEMPI CON TERRA!
 REMPLISSEZ-LE DE TERREAU!
 ILLENAR CON LA TIERRA!

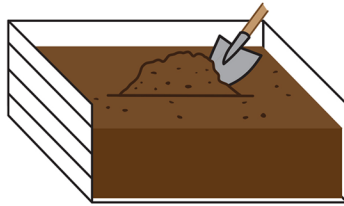

B.

MAKE YOUR OWN SOIL!
 PRODUZIEREN SIE EIGENE ERDE!
 PRODUCI LA TUE TERRA!
 CRÉEZ VOTRE PROPRE TERREAU!
 ICREA TU PROPRIA TIERRA!

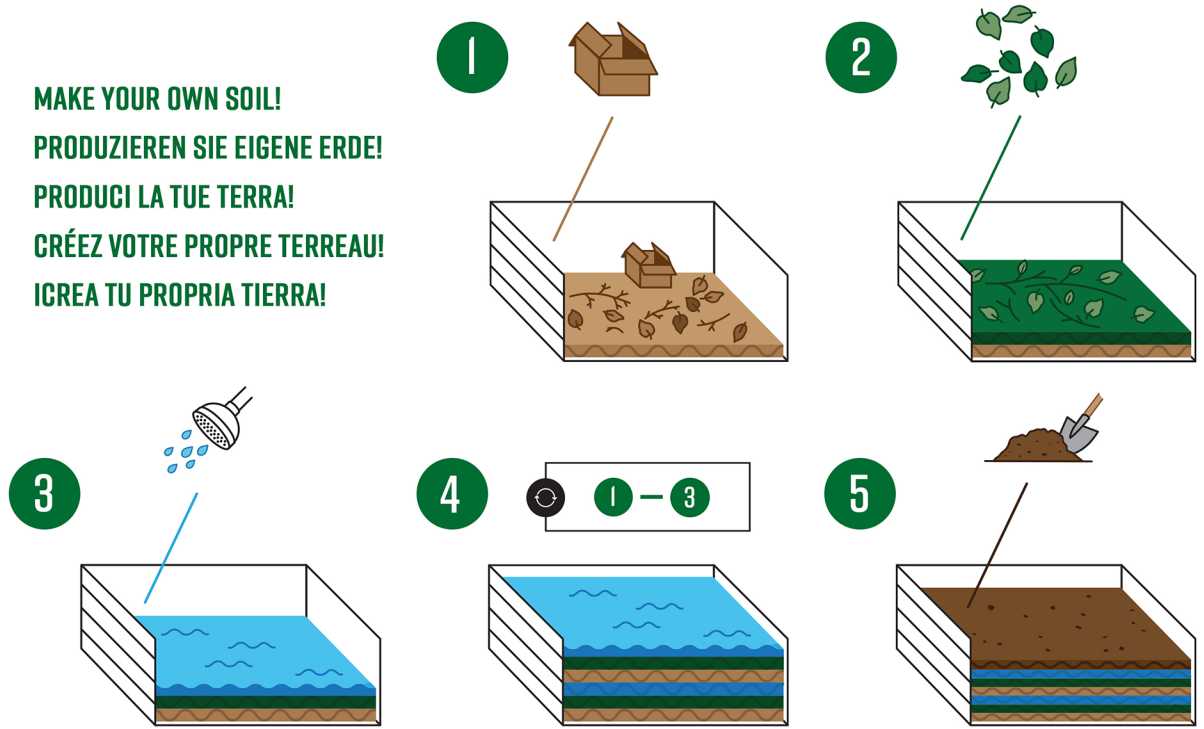

● CARBON | CARBONE | CARBÓN
 ● NITROGEN | AZOTE | NITRÓGENO

