

inMotion® *for health* **T900**
TREADMILL

Owner's Manual

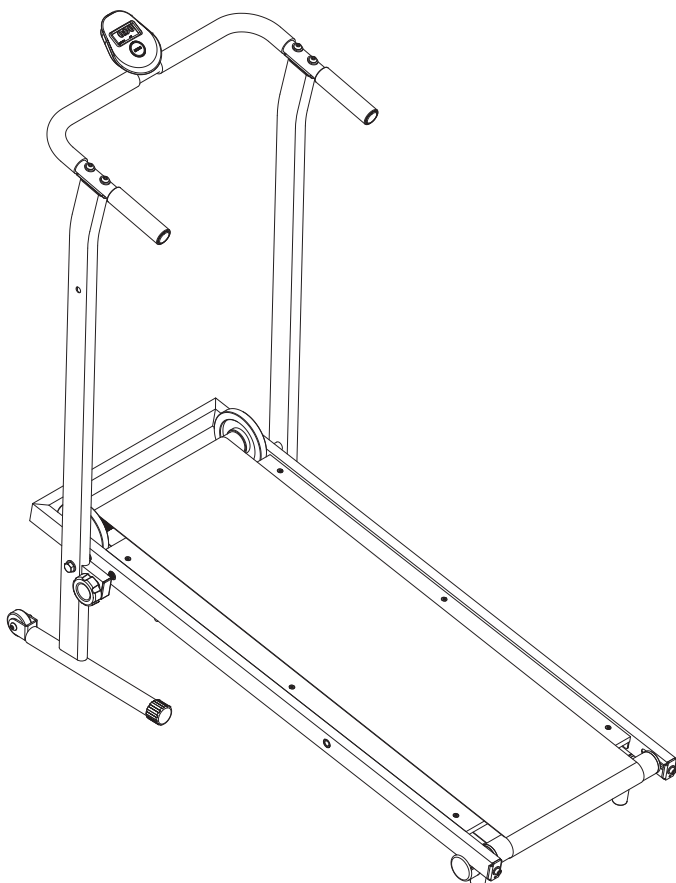

Product May Vary Slightly From Pictured.

CAUTION:
Weight on this product should not exceed 225 lbs.

This Product is Distributed Exclusively by



2040 N Alliance Ave, Springfield, MO 65803
Customer Care
1 (800) 375-7520
www.staminaproducts.com

⚠ WARNING ⚠

Exercise can present a health risk. Consult a physician before beginning any exercise program with this equipment. If you feel faint or dizzy, immediately discontinue use of this equipment. Serious bodily injury can occur if this equipment is not assembled and used correctly. Serious bodily injury can also occur if all instructions are not followed. Keep others and pets away from equipment when in use. Always make sure all bolts and nuts are securely tightened prior to each use. Follow all safety instructions in this manual.

When calling for parts or service, please specify the following numbers:

Model#: 45-0900B

S/N: _____

STAMINA PRODUCTS
MADE IN CHINA

© 2016 Stamina Products, Inc.
2019, 06

TABLE OF CONTENTS

Safety Instructions	2	Storage	13
Before You Begin	4	Conditioning Guidelines	14
Equipment Warning, Caution & Notice Labels ...	5	Warm-Up and Cool-Down	15
Hardware Identification Chart	6	Product Parts Drawing	16
Assembly Instructions	7	Parts List	17
Operational Instructions	10	Warranty	18
Maintenance	12	Fax/Mail Ordering Form	19

SAFETY INSTRUCTIONS

⚠ WARNING Cancer and Reproductive Harm www.P65Warnings.ca.gov

⚠ WARNING Consult your physician before starting this or any exercise program. This is especially important if you are over the age of 35, have never exercised before, are pregnant, or suffer from any health problem. This product is for home use only. Do not use in institutional or commercial applications. Failure to follow all warnings and instructions could result in serious injury or death.

⚠ WARNING To reduce the risk of serious injury, read the following Safety Instructions before using the inMotion® T900 Treadmill.

1. Save these instructions and ensure that other exercisers read this manual prior to using the inMotion® T900 Treadmill for the first time.
2. Read all warnings and cautions posted on the inMotion® T900 Treadmill.
3. The inMotion® T900 Treadmill should only be used after a thorough review of the Owner's Manual.
4. We recommend that two people be available for assembly of this product.
5. Keep children away from the inMotion® T900 Treadmill. Do not allow children to use or play on the inMotion® T900 Treadmill. Keep children and pets away from the inMotion® T900 Treadmill when it is in use.
6. It is recommended that you place this exercise equipment on an equipment mat.
7. Set up and operate the inMotion® T900 Treadmill on a solid level surface. Do not position the inMotion® T900 Treadmill on loose rugs or uneven surfaces.
8. Make sure that adequate space is available for access to and around the inMotion® T900 Treadmill.
9. Keep fingers clear of all pinch points when folding and unfolding the inMotion® T900 Treadmill.
10. Before using, inspect the inMotion® T900 Treadmill for worn or loose components, and securely tighten or replace any worn or loose components prior to use.
11. Before using, always check the BASE FRAME(1) to be sure it is secure. The LOCKING KNOB(5) must be inserted through the hole in the LEFT UPRIGHT(2) and tightened by screwing it into the BASE FRAME(1).
12. Consult a physician prior to commencing an exercise program and follow his/her recommendations in developing your fitness program. If at any time during exercise you feel faint, dizzy, or experience pain, stop and consult your physician.
13. Follow your physician's recommendations in developing your own personal fitness program.
14. Always choose the workout which best fits your physical strength and flexibility level. Know your limits and train within them. Always use common sense when exercising.
15. Do not wear loose or dangling clothing while using the inMotion® T900 Treadmill.
16. Never exercise in bare feet or socks; always wear proper footwear such as running, walking, or cross training shoes that fit well, provide foot support, and feature non-skid rubber soles.
17. Be careful to maintain your balance while using, mounting, dismounting, or assembling the inMotion® T900 Treadmill, loss of balance may result in a fall and serious bodily injury.
18. The inMotion® T900 Treadmill should not be used by persons weighing over 225 pounds.
19. The inMotion® T900 Treadmill should be used by only one person at a time.
20. The inMotion® T900 Treadmill is for consumer use only. It is not for use in public or semipublic facilities.

EXTEND YOUR PARTS WARRANTY TO 180 DAYS FROM THE DATE OF PURCHASE. REGISTER YOUR PRODUCT.



**NEED HELP?
CONTACT US FIRST
1 (800) 375-7520
customer.care@staminaproducts.com**

Hi! From all of us here at Stamina Products, thank you for your purchase. We know that you have big fitness goals in mind and we are here to help you along. Call us, email us, or send us a message on Facebook. Be sure to contact us if you have any questions on your new product. We look forward to hearing from you!

With your body in mind,
Stamina Customer Care

To enact your extended warranty and to help us better serve you, please go online and register your new product.

register.staminaproducts.com

It is quick and easy to register online, but if you're a little old school or just need a reason to raise that little flag on your mailbox, fill out the info on the last page of this manual and mail it in.



ONLINE

customer.care@staminaproducts.com
www.staminaproducts.com



TELEPHONE

1 (800) 375-7520



FAX

(417) 889-8064



MAIL

Stamina Products, Inc.
ATTN: Customer Care
2040 N Alliance Ave
Springfield, MO 65803

 facebook.com/StaminaProducts
facebook.com/AeroPilates

CUSTOMER CARE HOURS:
Monday-Thursday, 7:30 AM-5:00 PM, Central Time
Friday, 8:00 AM-3:00 PM, Central Time

BEFORE YOU BEGIN

Thank you for choosing the **inMotion® T900 Treadmill**. We take great pride in this quality product and hope it will provide many hours of quality exercise to make you feel better, look better, and enjoy life to its fullest.

It's a proven fact that a regular exercise program can improve your physical and mental health. Too often, our busy lifestyles limit our time and opportunity to exercise. The **inMotion® T900 Treadmill** provides a convenient and simple method to begin your journey of getting your body in shape and achieving a happier and healthier lifestyle.

Before reading further, please review the drawing below and familiarize yourself with the parts that are labeled. Locate the serial decal on the product and write the serial number on the cover of the manual in the space provided. See page 5 for an image of the serial decal. Model

number and serial number are required when calling for assistance.

Read this manual carefully before using the **inMotion® T900 Treadmill**.

Providing you with a quality product is Stamina's top priority. However, sometimes there could be a missing or incorrectly sized part. If you have any questions or problems with the parts included with your **inMotion® T900 Treadmill**, please do not return the product. Contact us **FIRST!**

If a part is missing or defective, please contact Customer Care for assistance. Call us toll free at 1-800-375-7520 (in the U.S.) or live chat on staminaproducts.com. Our Customer Care Staff is available to assist you from 7:30 A.M. to 5:00 P.M. (Central Time) Monday through Thursday and 8:00 A.M. to 3:00 P.M. (Central Time) on Friday.

Be sure to have the name and model number of the product available when you contact us.

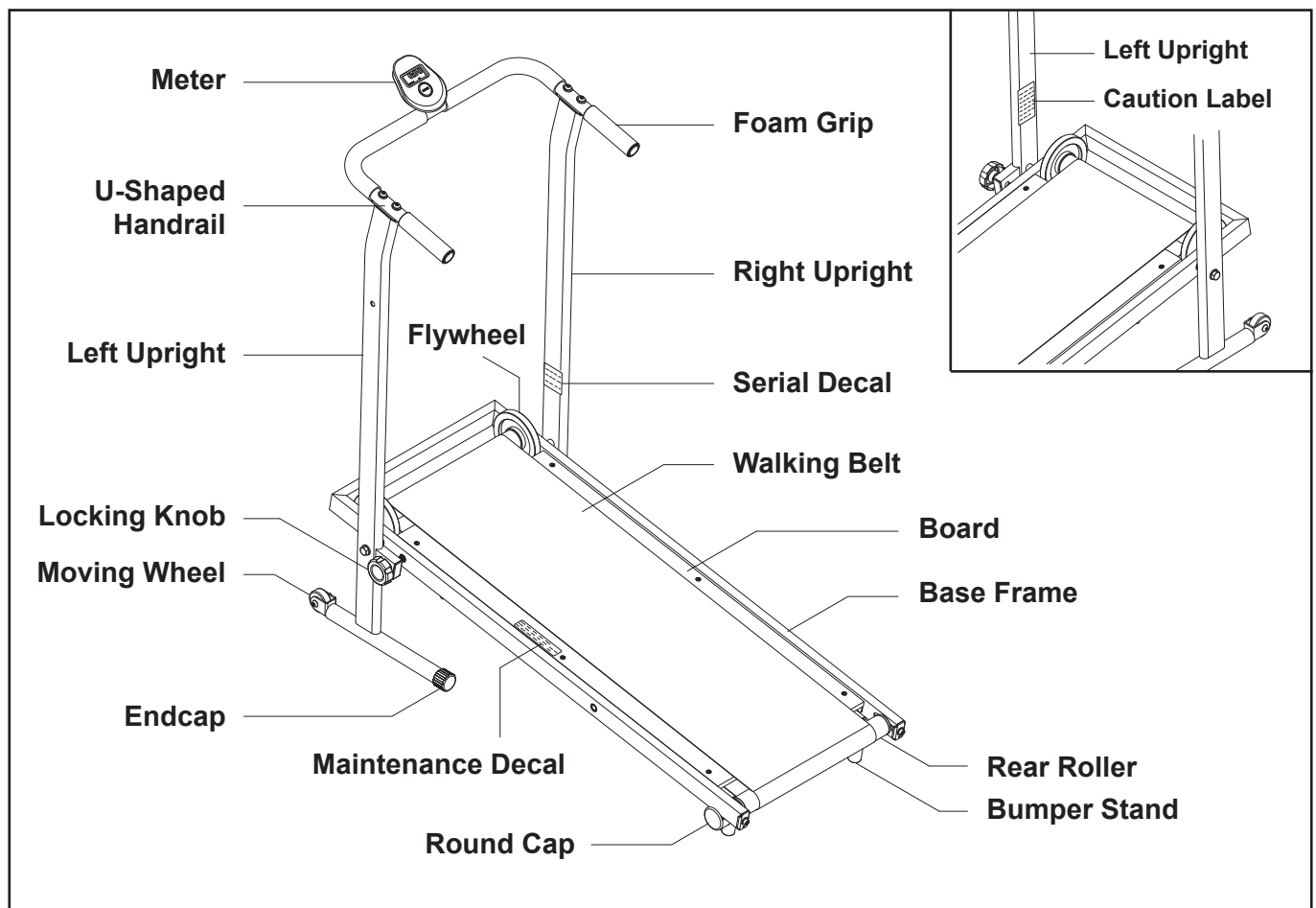

THE FOLLOWING TOOLS ARE INCLUDED FOR ASSEMBLY:



Wrench



Allen Wrench (5mm)

EQUIPMENT WARNING, CAUTION & NOTICE LABELS

This chart is provided to help identify the warning, caution, and notice labels on the **inMotion® T900 Treadmill**. Please take a moment to familiarize yourself with all of the warning, caution, and notice labels.

CAUTION LABEL(52)

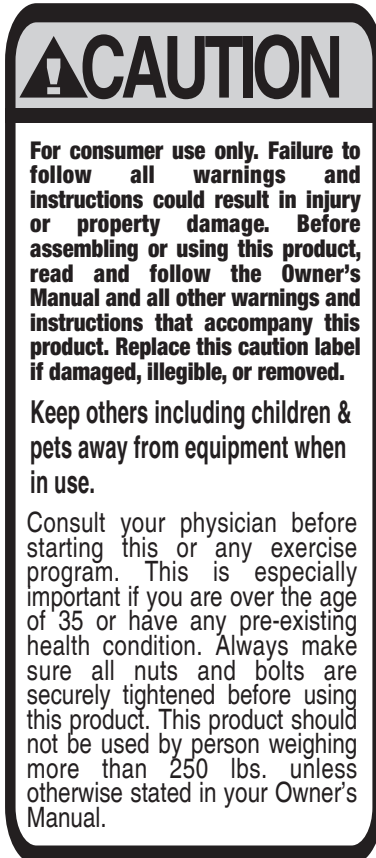

SERIAL DECAL(53)



To best serve you, our Customer Care Representatives will need your serial number. For quick access, write in your serial number on the cover of the manual.

MAINTENANCE DECAL(48)



HARDWARE IDENTIFICATION CHART

This chart is provided to help identify the hardware used in the assembly process. Place the washers or the ends of the bolts or screws on the circles to check for the correct diameter. Use the small scale to check the length of the bolts and screws.

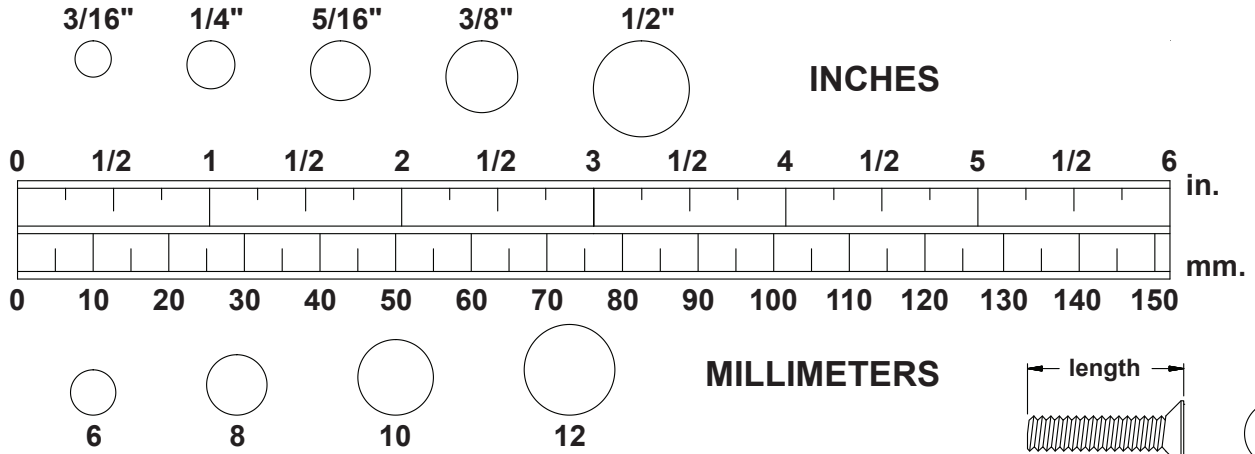

NOTICE: The length of all bolts and screws, except those with flat heads, is measured from below the head to the end of the bolt or screw. Flat head bolts and screws are measured from the top of the head to the end of the bolt or screw.

After unpacking the unit, open the hardware bag and make sure that you have all the following items. Some hardware may be already attached to the part.



Part Number and Description **Qty**

33 Bolt, Hex Head (M10 x 1.5 x 50mm) 2

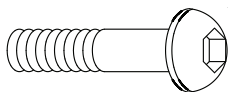

35 Bolt, Button Head (M8 x 1.25 x 35mm) 4



39 Arc Washer (M8) 4

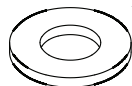

43 Washer (M10) 2

ASSEMBLY INSTRUCTIONS

Place all parts from the box in a cleared area and position them on the floor in front of you. Remove all packing materials from your area and place them back into the box. Do not dispose of the packing materials until assembly is completed. Read each step carefully before beginning. If you are missing a part, please go to staminaproducts.com under the Customer Care section and order the part needed, e-mail us at customer.care@staminaproducts.com, or call us toll free at 1-800-375-7520 (in the U.S.). Our Customer Care Staff is available to assist you from 7:30 A.M. to 5:00 P.M. (Central Time) Monday through Thursday and 8:00 A.M. to 3:00 P.M. (Central Time) on Friday.

Some product parts are fit tested at the factory to ensure proper fit and alignment. Marks in the paint may be noticeable, but are not an indication of damage.

STEP 1

Attach the **LEFT** and **RIGHT UPRIGHTS(2, 3)** to the **BASE FRAME(1)** with **HEX BOLTS(M10x1.5x50mm) (33)** and **WASHERS(M10)(43)**. **DO NOT TIGHTEN COMPLETELY.**

STEP 2

Connect the **LOWER EXTENSION WIRE(24)** located on the **LEFT UPRIGHT(2)** to the **SENSOR WIRE(25)**.

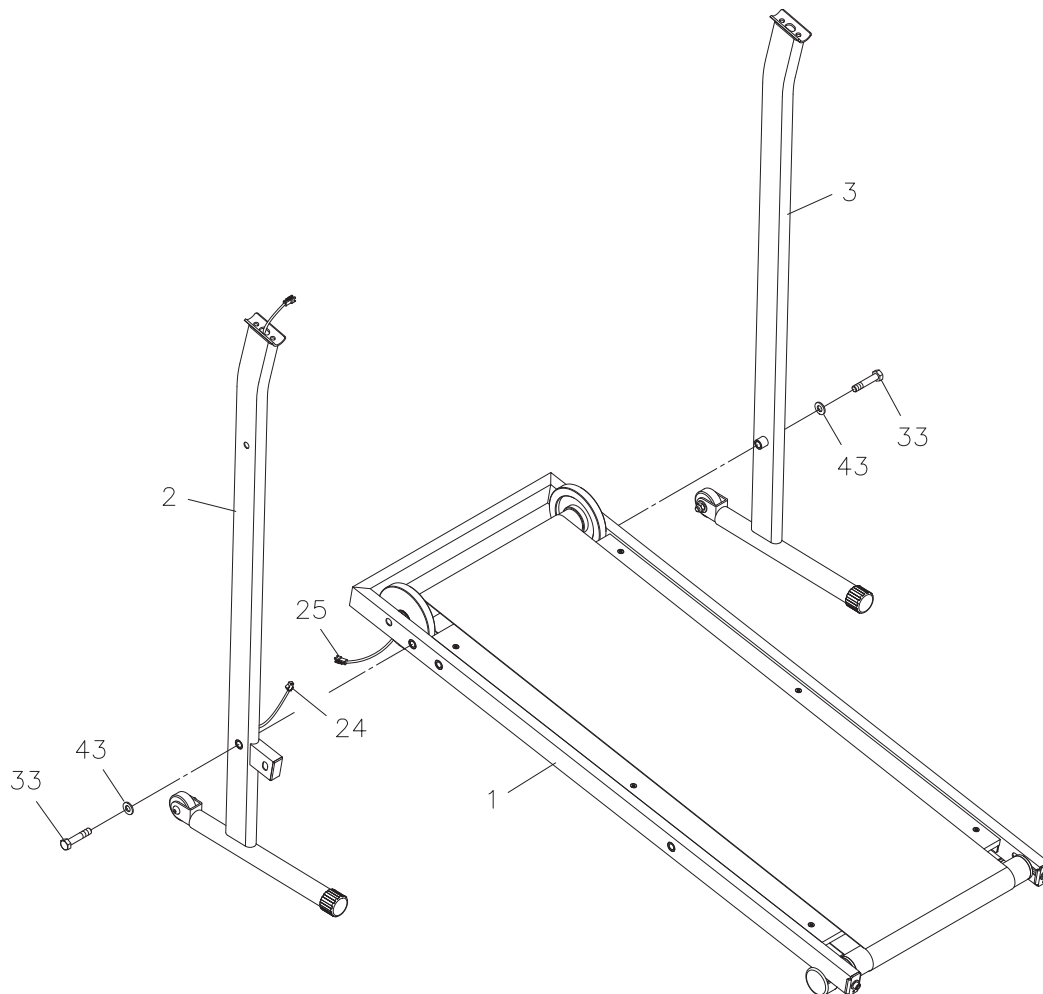

ASSEMBLY INSTRUCTIONS

STEP 3

Connect the **LOWER EXTENSION WIRE(24)** extending from the top of the **LEFT UPRIGHT(2)** to the **UPPER EXTENSION WIRE(23)** extending from the bottom of the **U-SHAPED HANDRAIL(4)**. Push extra wires back into the **LEFT UPRIGHT(2)**. Secure the **U-SHAPED HANDRAIL(4)** to the **LEFT** and **RIGHT UPRIGHTS(2, 3)** with **BUTTON HEAD BOLTS(M8x1.25x35mm)(35)** and **ARC WASHERS(M8)(39)**. Go back and tighten **HEX BOLTS(M10x1.5x50mm)(33)** in **STEP 1**.

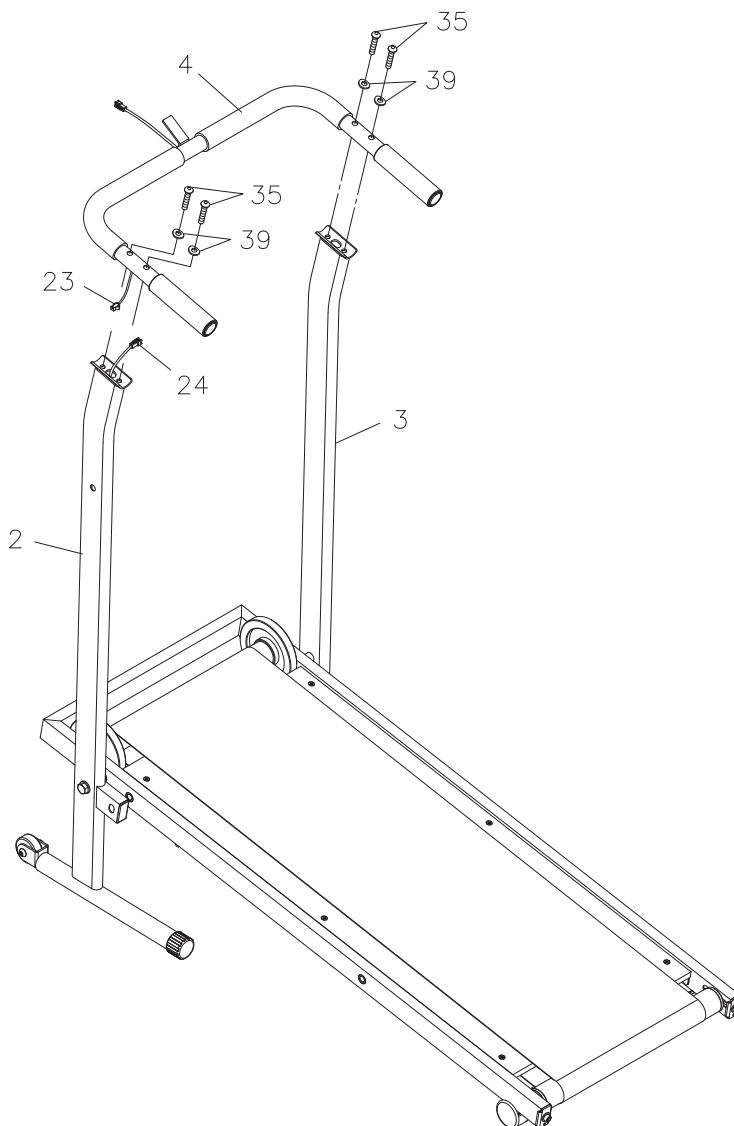

ASSEMBLY INSTRUCTIONS

STEP 4

Insert the **LOCKING KNOB(5)** through the **LEFT UPRIGHT(2)** and screw into the hole in the **BASE FRAME(1)** to lock the **BASE FRAME(1)** in position.

STEP 5

Install two AAA batteries into the **METER(21)**, the batteries are not included. See page 10 for detailed battery installation instructions. Slide the **METER(21)** onto the plate on the **U-SHAPED HANDRAIL(4)**. Connect the **UPPER EXTENSION WIRE(23)** to the **METER(21)**.

STEP 6

Attach the **BUMPER STANDS(17)** to the bottom of the **BASE FRAME(1)**.

NOTE: The **BUMPER STANDS(17)** may be stored on the end of the **BASE FRAME(1)** to increase the angle of the treadmill and reduce the walking resistance. See page 12 for details on adjusting the walking resistance.

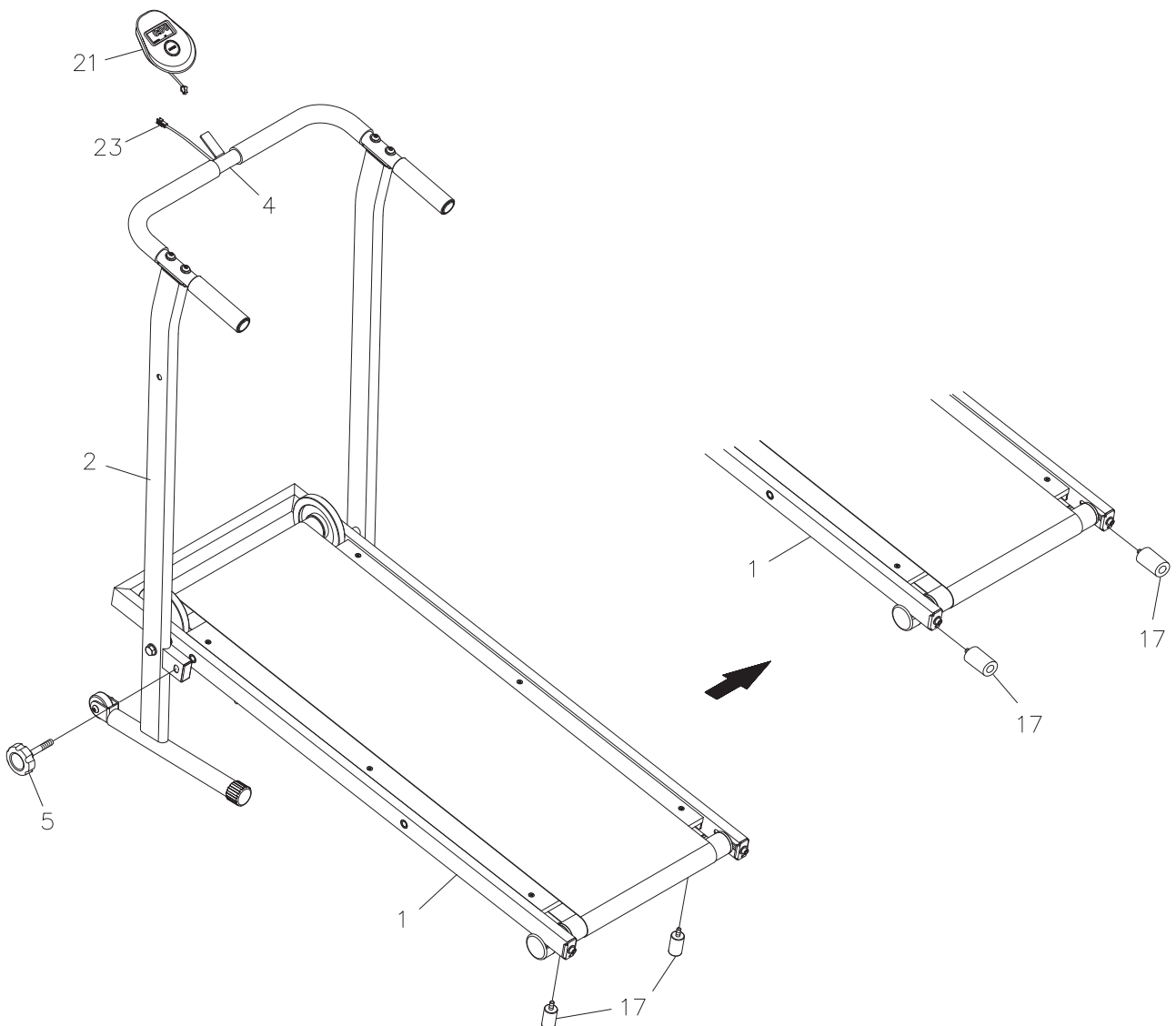

OPERATIONAL INSTRUCTIONS

USING THE FITNESS METER

POWER ON : Walking Belt movement or press the button.

POWER OFF : Automatically shuts off after four minutes of inactivity.

MODE BUTTON:

Press to select the function value displays of **SCAN, TIME, SPEED, DISTANCE,** and **CALORIES.**

Press and hold for three seconds to reset all functions to zero.

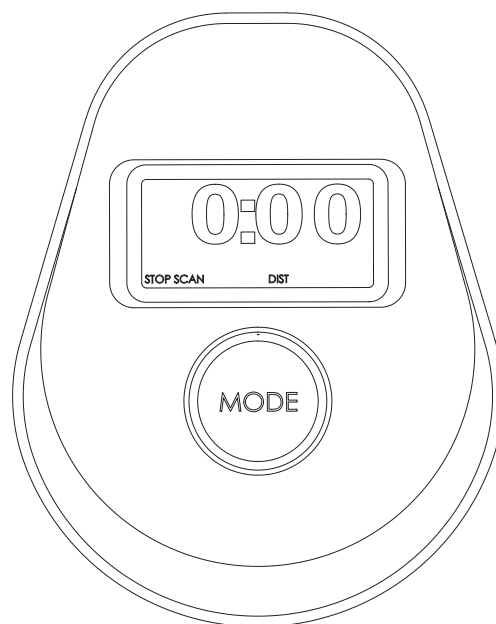

FUNCTIONS:

SCAN: Automatically scans each function of **TIME, SPEED, DISTANCE,** and **CALORIES** in sequence with change every six seconds. Press and release the button until "**SCAN**" appears on the display.

TIME: Displays the time from one second up to 99:59 minutes.

SPEED: Displays the current speed from zero to 99.9 miles per hour.

DISTANCE: Displays the distance from zero to 999.9 miles.

CALORIES: Displays the calorie burned from zero to 999.9 Kcal. The calorie readout is an estimate for an average user. It should be used only as a comparison between workouts on this unit.

NOTE: The meter will shut off automatically after four minutes of inactivity. All function values will be kept. You can continue to workout with these function values, or press the button and hold it down for three seconds to reset all functions to zero.

HOW TO INSTALL AND REPLACE BATTERIES:

1. Open the Battery Door on the back of the meter.
2. The meter operates with two AAA batteries (1.5V each), the batteries are not included. Refer to the illustration to install or replace the batteries.

- NOTE:**
1. Do not mix a new battery with an old battery.
 2. Use the same type of battery. Do not mix an alkaline battery with another type of battery.
 3. Rechargeable batteries are not recommended.
 4. **Ultimate disposal of battery should be handled according to all state and federal laws and regulations.**
 5. **Do not dispose of batteries in fire.**

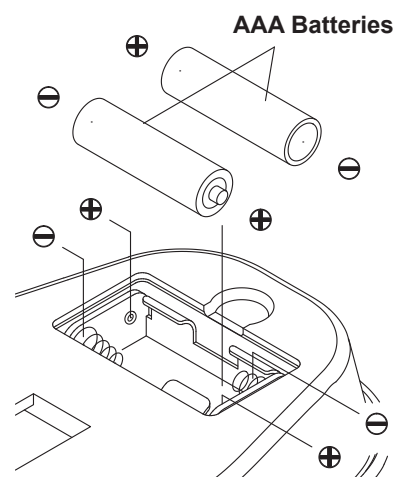

OPERATIONAL INSTRUCTIONS

TREADMILL ADJUSTMENTS

When adjusted properly, the **inMotion® T900 Treadmill's WALKING BELT(14)** will roll smoothly around the **BOARD(15)** and over the front and rear rollers without catching or rubbing. For the belt to run smoothly, there are a few points that need to be noted

BELT ALIGNMENT

The **WALKING BELT(14)** must be in the center of the **BOARD(15)** to prevent it from rubbing against the flywheels. If the belt rubs a flywheel, it will be difficult to keep the belt moving and will eventually damage the edge of the belt. The treadmill has belt guides welded to the bottom of the treadmill frame that move the belt toward the center of the treadmill. However, the **REAR ROLLER(10)** must be properly aligned with the treadmill frame and **FRONT ROLLER w/FLYWHEELS(6)** if the belt is to remain centered on the treadmill. The bolts in the rear of the treadmill (one on the left and the other on the right) adjust the alignment of the **REAR ROLLER(10)** as well as the tension of the belt

The belt will run to the side of the loose rear bolt.

Hint: Visually check the **REAR ROLLER(10)** to make sure both the right side and the left side of the **REAR ROLLER(10)** are the same distance from the back edge of the treadmill. Using the 5mm **ALLEN WRENCH**, make adjustments by turning the bolts clockwise to tighten and counterclockwise to loosen.

BELT DRIFTING LEFT

Adjust by turning the left screw 1/4 turn **CLOCKWISE** and the right screw 1/4 turn **COUNTERCLOCKWISE**. Walk on the treadmill to check alignment. Repeat if needed.

BELT DRIFTING RIGHT

Adjust by turning the left screw 1/4 turn **COUNTERCLOCKWISE** and the right screw 1/4 turn **CLOCKWISE**. Walk on the treadmill to check alignment. Repeat if needed.

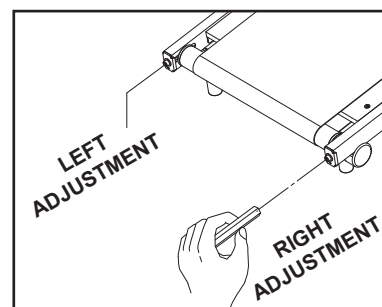

NOTE:

When you believe the **WALKING BELT(14)** is centered, use the treadmill for three (3) minutes to verify the **WALKING BELT(14)** won't drift to one side or the other. If the **WALKING BELT(14)** continues to drift, the floor may not be level. Rotate the treadmill 90 degrees or move the treadmill to another location.

BELT TENSION

The **WALKING BELT(14)** should be taut and not lying loosely on the treadmill **BOARD(15)**. If the belt is too loose, it will slip on the front roller and you will notice a jerky movement when you walk on the treadmill. If the belt is too tight, the edges of the belt will begin to curl and more effort will be required to move the belt. Excessive belt tension can also damage the bearings in the rollers. The bolts on the ends of the **BASE FRAME(1)** (one on the left and the other on the right) adjust the **WALKING BELT(14)** tension as well as the **REAR ROLLER(10)** alignment.

BELT TOO LOOSE: Use the 5mm **ALLEN WRENCH** to tighten the bolts on the ends of the **BASE FRAME(1)**. Tighten both bolts 1/4 turn at a time until the belt stops slipping on the **FRONT ROLLER w/FLYWHEELS(6)**.

BELT TOO TIGHT: Use the 5mm **ALLEN WRENCH** to loosen the bolts on the ends of the **BASE FRAME(1)**. Loosen both bolts 1/2 turn at a time until the belt begins to slip on the **FRONT ROLLER w/FLYWHEELS(6)**. Then use the procedure above to tighten the belt to the proper tension.

OPERATIONAL INSTRUCTIONS

WALKING RESISTANCE

The walking resistance or effort needed to push the treadmill belt can be adjusted by changing the incline angle. This treadmill has two adjustment positions.

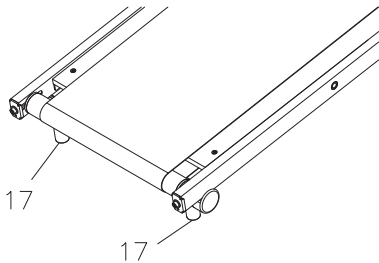

Highest Resistance

The **BUMPER STANDS(17)** are attached to the bottom of the treadmill.

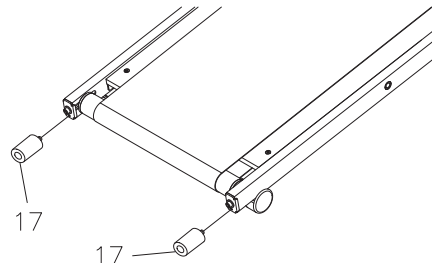

Lowest Resistance

Remove (unscrew) the **BUMPER STANDS(17)** from the bottom of the treadmill and store them in the end of the treadmill.

NOTE:

1. Since this is a new machine, you may need some time to get used to walking on the treadmill and to break it in.
2. If the walking resistance is still too high, check the **BELT TENSION**. Refer to page 11 for instructions to adjust belt tension.
3. The belt resistance can be reduced by adding silicone lubricant between the belt and the board. Wipe the board under the belt with a clean, dry cloth then spray or spread silicone lubricant on the board under the belt

MAINTENANCE

The safety and integrity designed into the **inMotion® T900 Treadmill** can only be maintained when the **inMotion® T900 Treadmill** is regularly examined for damage and wear. Special attention should be given to the following:

1. Clean the exposed surfaces of the walking belt and the board with an absorbent cloth.
2. Verify that the **LOCKING KNOB(5)** is present and functioning properly. Repair or replace parts as necessary.
3. Verify that all nuts and bolts are present and properly tightened. Replace missing nuts and bolts. Tighten loose nuts and bolts.
4. Verify that the **CAUTION LABEL(52)** is in place and easy to read. Call Stamina Products immediately at 1-800-375-7520 for a replacement **CAUTION LABEL(52)** if it is missing or damaged.
5. It is the sole responsibility of the user/owner to ensure that regular maintenance is performed.
6. Worn or damaged components must be replaced immediately or the **inMotion® T900 Treadmill** removed from service until repair is made.
7. Only Stamina Products supplied components should be used to maintain/repair the **inMotion® T900 Treadmill**.
8. Keep your **inMotion® T900 Treadmill** clean by wiping it off with an absorbent cloth after use.
9. If the **WALKING BELT(14)** does not move easily, lubricate the **BOARD(15)** under the **WALKING BELT(14)** with silicone lubricant.

STORAGE

1. To store the **inMotion® T900 Treadmill**, simply keep it in a clean dry place.
2. To avoid damage to the electronics, remove the batteries before storing the **inMotion® T900 Treadmill** for one year or more.
3. To fold the **inMotion® T900 Treadmill** for easy storage, follow this process. Refer to the illustrations below.
 - a. Remove the **LOCKING KNOB(5)** to unlock the **BASE FRAME(1)**.
 - b. Fold up the **BASE FRAME(1)**. To lock the **BASE FRAME(1)** in folded position, insert the **LOCKING KNOB(5)** through the hole in the **LEFT UPRIGHT(2)** and screw it into the **BASE FRAME(1)**.
CAUTION: Make sure the **BASE FRAME(1)** is locked securely in folded position by the **LOCKING KNOB(5)**.
4. Move the **inMotion® T900 Treadmill** with the moving wheels on the **LEFT** and **RIGHT UPRIGHTS(2, 3)**. Stand in front of the **inMotion® T900 Treadmill**, grasp the **U-SHAPED HANDRAIL(4)** and tilt it toward you to easily roll the **inMotion® T900 Treadmill**.

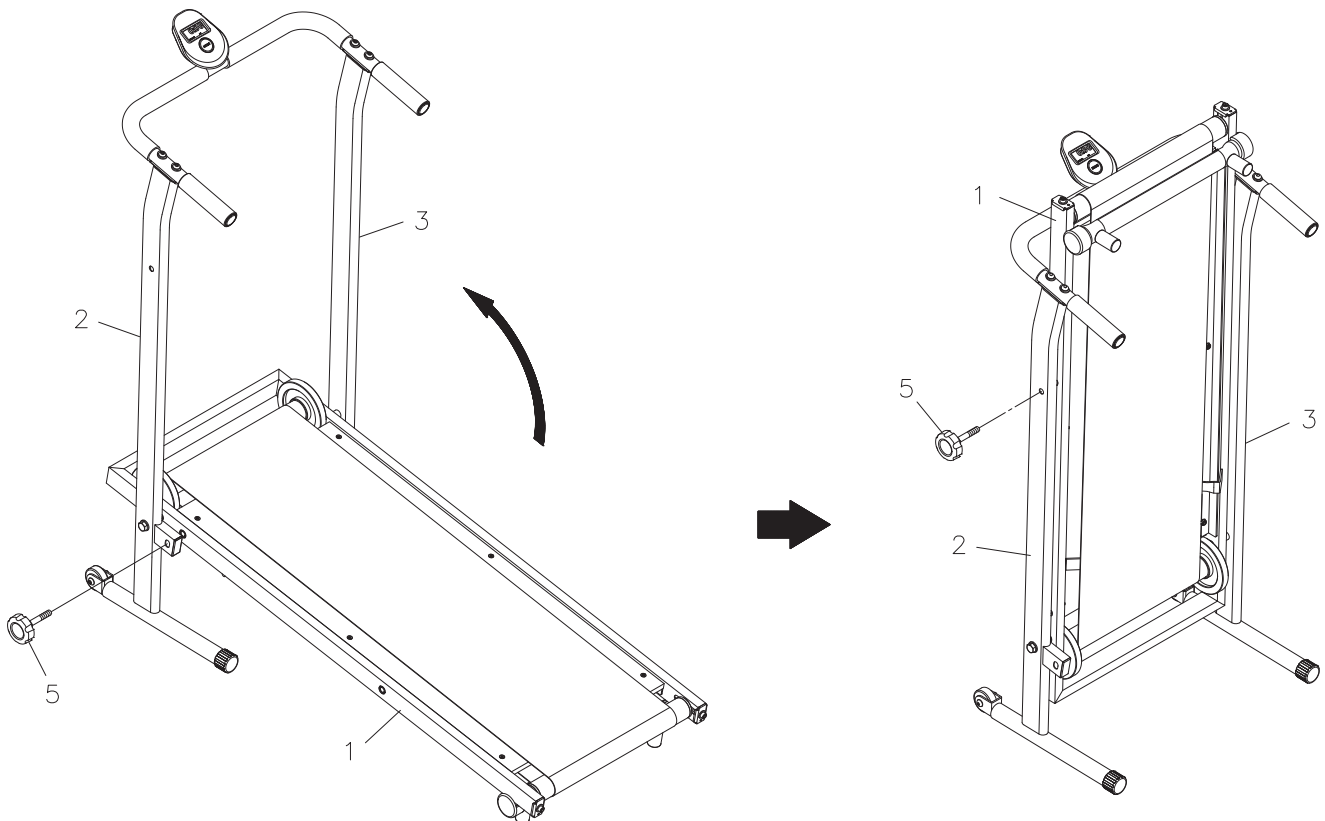

UNFOLD THE inMotion® T900 Treadmill

- a. Remove the **LOCKING KNOB(5)** to unlock the **BASE FRAME(1)**.
- b. Unfold the **BASE FRAME(1)** by lowering it. Lock the **BASE FRAME(1)** in position by inserting the **LOCKING KNOB(5)** through the hole in the **LEFT UPRIGHT(2)** and screwing it into the **BASE FRAME(1)**.

CONDITIONING GUIDELINES

How you begin your exercise program depends on your physical condition. If you have been inactive for several years or are severely overweight, start slowly and increase your workout time gradually. Increase your workout intensity gradually by monitoring your heart rate while you exercise.

Remember to follow these essentials:

- Have your doctor review your training and diet programs.
- Begin your training program slowly with realistic goals that have been set by you and your physician.
- Warm up before you exercise and cool down after you work out.
- Take your pulse periodically during your workout and strive to stay within a range of 60% (lower intensity) to 90% (higher intensity) of your maximum heart rate zone. Start at the lower intensity, and build up to higher intensity as you become more aerobically fit.
- If you feel dizzy or lightheaded you should slow down or stop exercising.

Initially you may only be able to exercise within your target zone for a few minutes; however, your aerobic capacity will improve over the next six to eight weeks. It is important to pace yourself while you exercise so you don't tire too quickly.

To determine if you are working out at the correct intensity, use a heart rate monitor or use the table below. For effective aerobic exercise, your heart rate should be maintained at a level between 60% and 90% of your maximum heart rate. If just starting an exercise program, work out at the low end of your target heart rate zone. As your aerobic capacity improves, gradually increase the intensity of your workout by increasing your heart rate.

Measure your heart rate periodically during your workout by stopping the exercise but continuing to move your legs or walk around. Place two or three fingers on your wrist and take a six second heartbeat count. Multiply the results by ten to find your heart rate. For example, if your six second heartbeat count is 14, your heart rate is 140 beats per minute. A six second count is used because your heart rate will drop rapidly when you stop exercising. Adjust the intensity of your exercise until your heart rate is at the proper level.

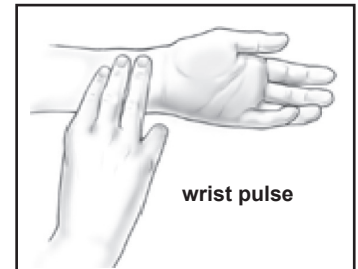

Target Heart Rate Zone Estimated by Age*

Age	Target Heart Rate Zone (55%-90% of Maximum Heart Rate)	Average Maximum Heart Rate 100%
20 years	110-180 beats per minute	200 beats per minute
25 years	107-175 beats per minute	195 beats per minute
30 years	105-171 beats per minute	190 beats per minute
35 years	102-166 beats per minute	185 beats per minute
40 years	99-162 beats per minute	180 beats per minute
45 years	97-157 beats per minute	175 beats per minute
50 years	94-153 beats per minute	170 beats per minute
55 years	91-148 beats per minute	165 beats per minute
60 years	88-144 beats per minute	160 beats per minute
65 years	85-139 beats per minute	155 beats per minute
70 years	83-135 beats per minute	150 beats per minute

* For cardiorespiratory training benefits, the American College of Sports Medicine recommends working out within a heart rate range of 55% to 90% of maximum heart rate. To predict the maximum heart rate, the following formula was used: $220 - \text{Age} = \text{predicted maximum heart rate}$

WARM-UP and COOL-DOWN

Warm-Up The purpose of warming up is to prepare your body for exercise and to minimize injuries. Warm up for two to five minutes before strength training or aerobic exercising. Perform activities that raise your heart rate and warm the working muscles. Activities may include brisk walking, jogging, jumping jacks, jump rope, and running in place

Stretching Stretching while your muscles are warm after a proper warm-up and again after your strength or aerobic training session is very important. Muscles stretch more easily at these times because of their elevated temperature, which greatly reduces the risk of injury. Stretches should be held for 15 to 30 seconds. Do not bounce.

Suggested Stretching Exercises

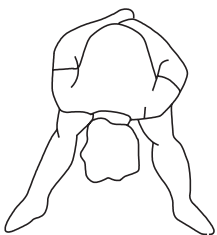

Lower Body Stretch

Place feet shoulder-width apart and lean forward. Keep this position for 30 seconds using the body as a natural weight to stretch the backs of the legs. **DO NOT BOUNCE!** When the pull on the back of the legs lessens, gradually try a lower position.

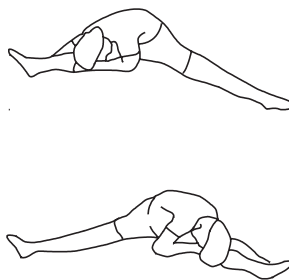

Floor Stretch

While sitting on the floor, open the legs as wide as possible. Stretch the upper body toward the knee on the right leg by using your arms to pull your chest to your thighs. Hold this stretch 10 to 30 seconds. **DO NOT BOUNCE!** Do this stretch 10 times. Repeat the stretch with the left leg.

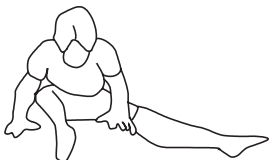

Bent Torso Pulls

While sitting on the floor, have legs apart, one leg straight and one knee bent. Pull the chest down to touch the thigh on the leg that is bent, and twist at the waist. Hold this position at least 10 seconds. Repeat 10 times on each side.

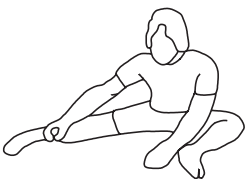

Bent Over Leg Stretch

Stand with feet shoulder-width apart and lean forward as illustrated. Using the arms, **gently** pull the upper body towards the right leg. Let the head hang down. **DO NOT BOUNCE!** Hold the position a minimum of 10 seconds. Repeat pulling the upper body to the left leg. Do this stretch several times slowly.

Remember to always check with your physician before starting any exercise program.

Cool-Down The purpose of cooling down is to return the body to its normal, or near normal, resting state at the end of each exercise session. A proper cool-down slowly lowers your heart rate and allows blood to return to the heart. Your cool-down should include the stretches listed above and should be completed after each strength training session.

PRODUCT PARTS DRAWING

FRONT

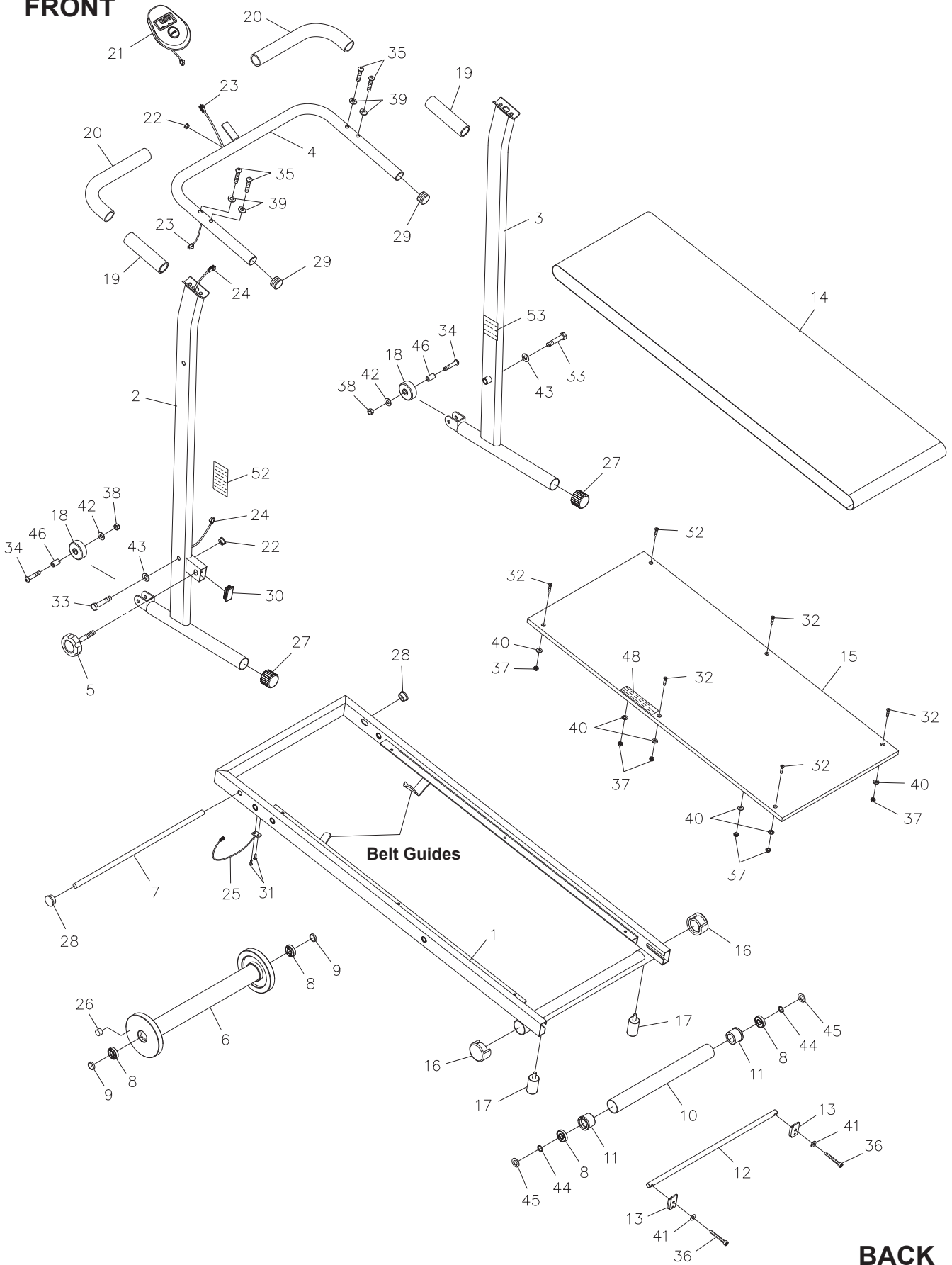

PARTS LIST

PART#	PART NAME	QTY
1	Base Frame	1
2	Left Upright	1
3	Right Upright	1
4	U-Shaped Handrail	1
5	Locking Knob	1
6	Front Roller w/ Flywheels	1
7	Front Shaft	1
8	Bearing (6201)	4
9	Bearing Spacer (ø13 x ø16 x 3mm)	2
10	Rear Roller	1
11	Bearing Housing	2
12	Rear Shaft	1
13	Adjustment Bracket	2
14	Walking Belt	1
15	Board	1
16	Round Cap (38mm)	2
17	Bumper Stand	2
18	Moving Wheel	2
19	Foam Grip	2
20	Long Foam Grip	2
21	Meter	1
22	Grommet Plug	2
23	Upper Extension Wire	1
24	Lower Extension Wire	1
25	Sensor Wire	1
26	Magnet	1
27	Endcap (31.8mm)	2
28	Round Plug (16mm)	2
29	Round Plug (25.4mm)	2
30	Rectangular Plug (20mm x 40mm)	1
31	Screw, Round Head (M3 x 10mm)	2
32	Screw, Flat Head (M5 x 23mm)	6
33	Bolt, Hex Head (M10 x 1.5 x 50mm)	2
34	Bolt, Button Head (M8 x 1.25 x 38mm)	2
35	Bolt, Button Head (M8 x 1.25 x 35mm)	4
36	Bolt, Socket Head (M6 x 1 x 55mm)	2
37	Nylock Nut (M5 x 0.8)	6
38	Nylock Nut (M8 x 1.25)	2
39	Arc Washer (M8)	4
40	Washer (M5)	6
41	Washer (M6)	2
42	Washer (M8)	2
43	Washer (M10)	2
44	Washer (M12 x ø16 x 1mm Thick)	2
45	Washer (M12 x ø22 x 2mm Thick)	2
46	Wheel Bushing (ø8.2 x ø12 x 20.2mm)	2
48	Maintenance Decal	1
49	Wrench	1
50	Allen Wrench (5mm)	1
51	Owner's Manual	1
52	Caution Label	1
53	Serial Decal	1

LIMITED WARRANTY

MODEL 45-0900B

WARRANTY

Stamina Products, Inc. ("Stamina") warrants to the original purchaser that this product will be free from defects in materials and workmanship that arise under normal use, service, proper assembly and proper operation in accordance with product warnings/instructions for a period of 90 days on the parts and one year on the frame from the date of the original purchase from an authorized retailer. **THIS WARRANTY SHALL NOT APPLY TO ANY PRODUCT WHICH HAS BEEN SUBJECT TO COMMERCIAL USE, ABUSE, MISUSE, ALTERATION OF ANY KIND OR TO ANY DEFECT OR CHANGE CAUSED BY IMPROPER ASSEMBLY, REPAIR, REPLACEMENT, SUBSTITUTION OR USE WITH PARTS NOT PROVIDED BY STAMINA.** Commercial use includes use of product in athletic clubs, health clubs, spas, gyms, and all other public or semipublic facilities whether or not the product's use is in furtherance of a profit making enterprise, and all other use which is not for personal purposes.

To implement this limited warranty, send a written notice stating your name, date, and place of purchase and a brief description of the defect along with your receipt to Stamina Products, Inc. 2040 N Alliance Ave, Springfield, Missouri, USA, MO 65803, or email us at customer.care@staminaproducts.com, or call us at 1-800-375-7520. If the defect is covered under this limited warranty, you will be requested to return the product or part to us for free repair or replacement at our option.

NO ACTION FOR BREACH OF THIS LIMITED WARRANTY MAY BE COMMENCED MORE THAN ONE (1) YEAR AFTER THE DATE THE ALLEGED BREACH WAS OR SHOULD HAVE BEEN DISCOVERED. NO ACTION FOR BREACH OF ANY IMPLIED WARRANTY (INCLUDING MERCHANTABILITY AND FITNESS FOR A PARTICULAR PURPOSE) MAY BE COMMENCED MORE THAN ONE (1) YEAR AFTER DELIVERY OF THE PRODUCT TO THE PURCHASER. These warranties are not transferable. IF ANY PART OF THE PRODUCT IS NOT IN COMPLIANCE WITH THIS LIMITED WARRANTY OR ANY IMPLIED WARRANTY, THE REMEDY OF REPAIR OR REPLACEMENT IS THE EXCLUSIVE REMEDY. If any claim is made under this limited warranty or any implied warranty, Stamina reserves the right to require the product to be returned for inspection, at the purchaser's expense, to Stamina's premises in Springfield, Missouri. Return of the enclosed warranty registration card is not required for warranty coverage, but is merely a way of establishing the date and place of purchase.

Stamina **SHALL NOT BE LIABLE FOR THE LOSS OF USE OF ANY PRODUCT, LOSS OF TIME, INCONVENIENCE, COMMERCIAL LOSS OR ANY OTHER INDIRECT, CONSEQUENTIAL, SPECIAL OR INCIDENTAL DAMAGES DUE TO BREACH OF THE ABOVE WARRANTY OR ANY IMPLIED WARRANTY.**

THIS LIMITED WARRANTY IS THE ONLY EXPRESS WARRANTY. NO ORAL OR WRITTEN INFORMATION GIVEN BY STAMINA, ITS AGENTS OR EMPLOYEES, SHALL CREATE A WARRANTY OR IN ANY WAY INCREASE THE SCOPE OF THIS WARRANTY. This warranty gives you specific legal rights, and you may also have other legal rights which vary from state to state. **ANY OTHER RIGHT WHICH YOU MAY HAVE, INCLUDING ANY IMPLIED WARRANTY OF MERCHANTABILITY OR FITNESS FOR A PARTICULAR PURPOSE, IS LIMITED IN DURATION TO THE DURATION OF THIS WARRANTY.**

The laws in some states affect the disclaimer or limitation of implied warranties and consequential and incidental damages. If any such law is found applicable, the foregoing disclaimers and limitations of and on implied warranties and consequential and incidental damages shall be deemed to be modified to the extent necessary to comply with applicable law.

TO CONTACT CUSTOMER CARE

For your convenience, Stamina's customer care representatives can be reached by email at customer.care@staminaproducts.com or by phone at 1-800-375-7520 (in the U.S.). Our customer care representatives are available Monday through Thursday from 7:30 a.m. until 5:00 p.m., and Friday 8:00 a.m. until 3 p.m. Central Time.



**ONLINE
CUSTOMER CARE**
customer.care@staminaproducts.com
www.staminaproducts.com



**TELEPHONE
CUSTOMER CARE**
Tel: 1 (800) 375-7520



**FAX
CUSTOMER CARE**
Fax: (417) 889-8064



MAIL
STAMINA PRODUCTS, INC.
ATTN: Customer Care
2040 N Alliance Ave, Springfield, MO 65803

Would you like to receive email information or special offers from Stamina Products? Register at contact.staminaproducts.com

TO REGISTER YOUR PRODUCT

To enact your warranty, please register your product by going to register.staminaproducts.com. Please have your product model number (printed on the cover of this owner's manual) and the serial number (printed on the black and white sticker on your product) ready.

If you don't have internet access, you can call customer care at 1-800-375-7520, or fill out and mail the product registration form below to Stamina Products, Inc.; 2040 N Alliance Ave, Springfield, MO 65803.

PRODUCT REGISTRATION FORM		Stamina Products, Inc. 2040 N Alliance Ave, Springfield, MO 65803	
Model Number:		Serial Number:	
Product Name:			
Place Purchased:			
Date of Purchase:		Purchase Price:	
First Name:		Last Name:	
City:	State:	Phone #: ()	Zip Code:
Email Address:		Phone #: ()	
Would you like to receive email information or special offers from Stamina Products?* <input type="checkbox"/> Yes <input type="checkbox"/> No *If yes, be sure your email address is included above.			



Detach and Mail or Fax the Form Above



TO ORDER PARTS

If there are missing or damaged parts, you can go to parts.staminaproducts.com and order those parts. If you have questions, please contact customer care. Do not return the product. To order parts by mail, fill out the sheet below and fax it to 417-889-8064. The part will be mailed to your address.



Detach and Mail or Fax the Form Below



PARTS ORDER FORM		Stamina Products, Inc. 2040 N Alliance Ave, Springfield, MO 65803	
Mr./Ms:			
Address:		Apt. #:	
City:	State:	Zip Code:	
IMPORTANT : We require your phone number to process the order!			
Phone #: ()		Work Phone #: ()	
Date of Purchase:			
Model #:			
Purchased From:			
IMPORTANT: Before filling out the portion below, make sure you have the correct information. Refer to the parts list to make sure you're ordering the right parts!			
PART #	DESCRIPTION	QUANTITY	
EXAMPLE: 1	Rear Unit Assembly	1	