

ITEM NO.	P/N	DESCRIPTION	QTY.
1	BPWV	BASE	2
2	NKSL-58	Support	2
3	HB2T-1	HUB	2
4	NKSL-78	Connector	4
5	BL1T-34	End Ball	2
6	BL1T-12	Small End Ball	2
7	NKSL-1.25	Neck	2
8	HKETS-38	Pipe	1

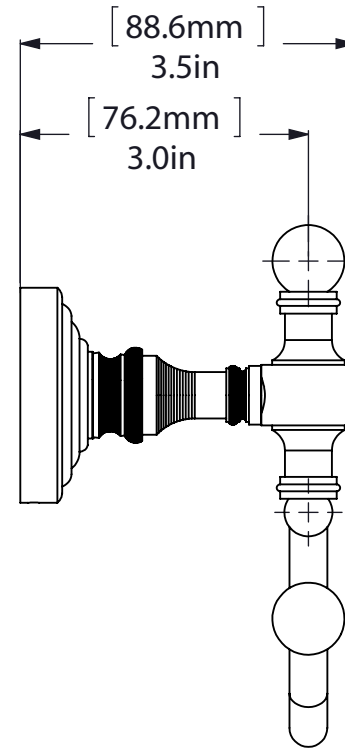
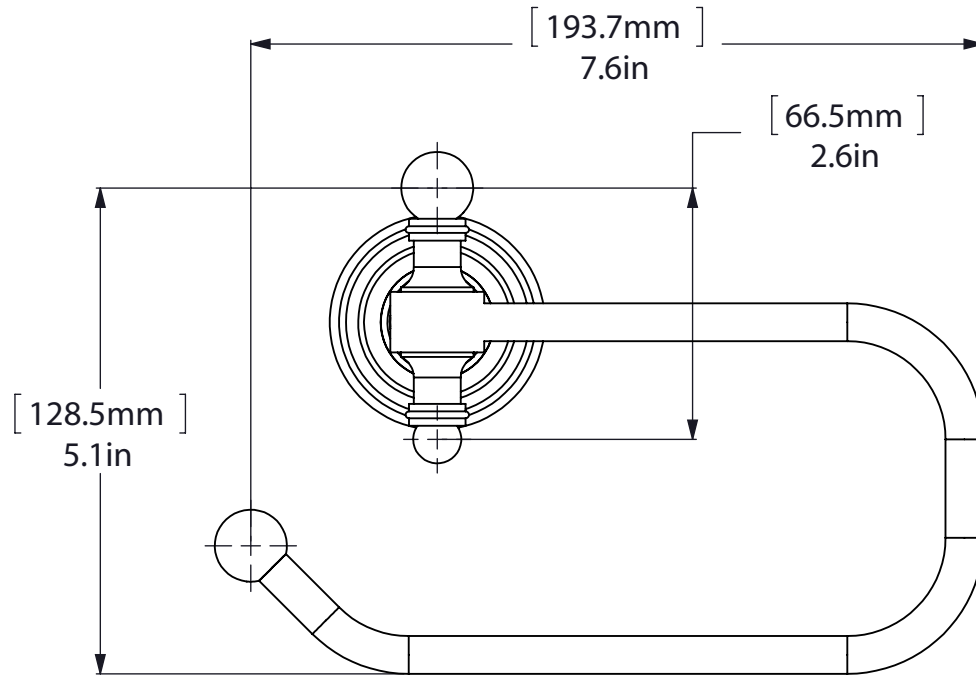
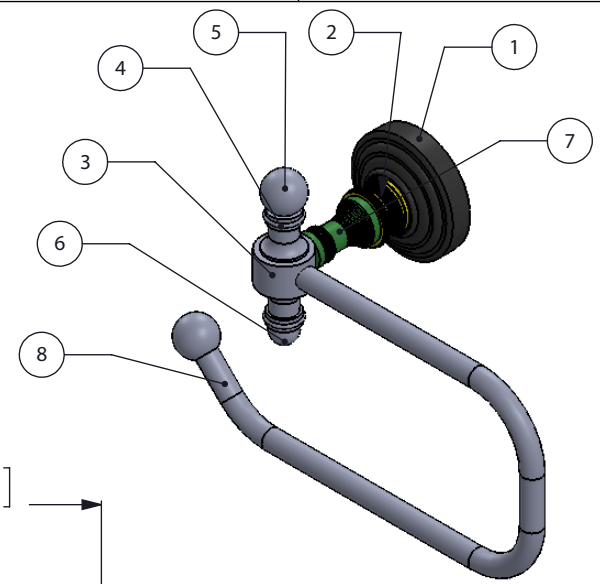

**CONFIDENTIALITY/LIMITED LIABILITY STATEMENT**  
 This document (and any files attached to it) is confidential and intended only for the person or entity to which it is delivered. If you are not the intended recipient, then you have received this document by mistake and any use, dissemination, forwarding, printing or copying of this document and its file attachments is prohibited. Please notify ALLIED BRASS INC. immediately either by telephone or by email, delete the misdirected document from your system and destroy any copies you have made of it. We do not accept any liability for any loss or damage which may arise from your receipt of this document.

UNLESS OTHERWISE STATED			INITIALS	DATE	ITEM	QTY	DRG/PART NO	CLIENT:			
DO NOT SCALE	X.XXX	+/-0.025	DESIGNED	IJM	MATERIAL		BRASS	WEIGHT		FINISH	TBD
DRAWING	X.XX	+/-0.1	DRAWN	IJM	HEAT TREAT		NA	QUANTITY			
CHAMFER ALL	X	+/-0.75	CHECKED	R. ANDRIS	CUSTOMER			CUSTOMER No		---	
EDGES 0.5X4*	ANGLES	X.XX	PROJ.ENG		DESCRIPTION:		RW-24E			DRAWING No.	
DRAWING ISO										RW-24E	
	X	+/-0.5*	APPROVED	R. ANDRIS					SCALE	1:1	
	X	+/-0.1*	FILENAME	RW-24E					SHEET: 01	A4	
		3.2									