

# Paramount

ITEM # - ES-207-BK  
MODEL # - BLT-999B-9

## Installation and Operation Instructions



### **READ & SAVE THESE INSTRUCTIONS**

Carefully read and review before assembling, installing, operating or maintaining this product. Observe all safety instructions and information.

**FAILURE TO FOLLOW WARNINGS & OPERATIONAL INSTRUCTIONS CONTAINED IN THIS MANUAL CAN RESULT IN PROPERTY DAMAGE OR PERSONAL INJURY.**



REV18-01



### **Questions, problems, missing parts?**

*Before returning to your retailer, contact our exceptional customer service.*

Contact us by email at [customer care@jrhome.com](mailto:customer care@jrhome.com) or call us toll free at (800) 561-5550, 7:30 a.m. - 4:00 p.m., PT, Monday - Friday

# TABLE OF CONTENTS

---

|                                     |            |
|-------------------------------------|------------|
| Important Safety Instructions ..... | <b>2-3</b> |
| Listing Approvals .....             | <b>4</b>   |
| Operating Instructions .....        | <b>5</b>   |
| Control Buttons/Functions .....     | <b>6</b>   |
| Maintenance .....                   | <b>7</b>   |
| Trouble shooting.....               | <b>8</b>   |
| Warranty.....                       | <b>9</b>   |

## CONSUMER SAFETY INFORMATION

---

- Read this manual before installing and operating this appliance.
- Failure to follow these instructions may result in electric shock, fire property damage, personal injury and will void the warranty.
- Requires the use of Fireplace Mantel.
- Do not store or use gasoline or other flammable liquids or vapors in the vicinity of this appliance.

## IMPORTANT SAFETY INSTRUCTIONS

---

When using electrical appliances, basic precautions should always be followed to reduce the risk of fire, electric shock and injury to persons including the following:

1. The manufacturers instructions completely before using this appliance.
2. This appliance will become hot when in use. To avoid burns, do not let bare skin touch hot surfaces. The grill at the top of this heater in partcular will become hot when the heater is active. Keep combustible materials such as furniture, pillows, bedding, paper, cloth, curtains, etc. at least 3 feet (0.9meter) away from the front of the appliance. Keep all items away from the sides and back of the appliance and take special care not to block the air intake or exhaust vents.
3. Extreme caution is necessary when the appliance is used by or near children or invalids and whenever the heater is left operating and unattended.
4. Do not operate the heater if the power cord or plug has been damaged or the heater has been damaged or malfunctioned in any way. Take the appliance to an authorized service facility for examination, electrical or mechanical adjustment or repair.
5. Do not use outdoors.
6. Do not use the appliance in bathrooms, laundry rooms or other similar indoor locations where it may contact water. Never locate the appliance where it may fall into a bathtub or other water container.
7. Do not run the power cord under carpeting. Do not cover the power cord with throw rugs, runners, or similar floor coverings. Take care to position the cord away from high traffic areas and such that it can't be tripped over.
8. To disconnect the appliance, turn all controls "OFF", and then remove the plug from the electrical outlet.
9. The appliance comes equipped with a 3 prong-grounding plug. Do not attempt to cut the grounding prong. Connect to properly grounded 120V outlets only. This appliance, when installed, must be electrically grounded in accordance with local codes or, in the absence of local codes, with the power current.
10. Do not insert or allow foreign objects to enter any ventilation or exhaust openings as this may cause an electric shock or fire, or damage the appliance.
11. To prevent a possible fire, do not block air intakes or exhausts in any manner. Do not use on soft surfaces, like a bed, where openings may become blocked.

12. All electrical heaters have hot and arcing or sparking parts inside. Do not use in areas where gasoline, paint, or flammable liquids are used or stored or where the appliance will be exposed to flammable vapors.

13. Avoid using the appliance with an extension cord. Extension cords may overheat and cause a risk of fire. If an extension cord MUST be used, the cord must be No.16 AWG minimum size and rated not less than 1875 Watts. The extension cord must be a 3-prong cord with grounding type plug and cord connection and should not exceed 20' (6m) in length.

14. When transporting or storing the heater, take care to keep both the unit and power cord / plug dry, free from excessive vibration and away from heat sources.

15. Use the heater only as described in this manual. Any other use not recommended by the manufacturer may cause fire, electric shock, or injury to persons.

16. Do not attempt to burn wood or other materials in this heater.

## **SAVE THESE INSTRUCTIONS**

---

## LISTING APPROVALS

---

This heater has been tested in accordance with the CSA Standards.

|               |                    |
|---------------|--------------------|
| Model Number: | XFRST2029-1        |
| Description:  | Electric Fireplace |
| Voltage:      | 120V AC, 60Hz      |
| Watts:        | MAX 1500 W         |
| Length:       | 19.7"              |
| Height:       | 28.9"              |
| Depth:        | 12.6"              |

## OPERATING INSTRUCTIONS

---

Read all instructions and warning prior to operating the appliance.

Ensure that all control are in the "OFF" position before plugging the appliance into a properly grounded electrical outlet.

The main switch is located at the top left corner on the front(see Figure 1)

The main control buttons are located at the top right corner on the front(see Figure 1)

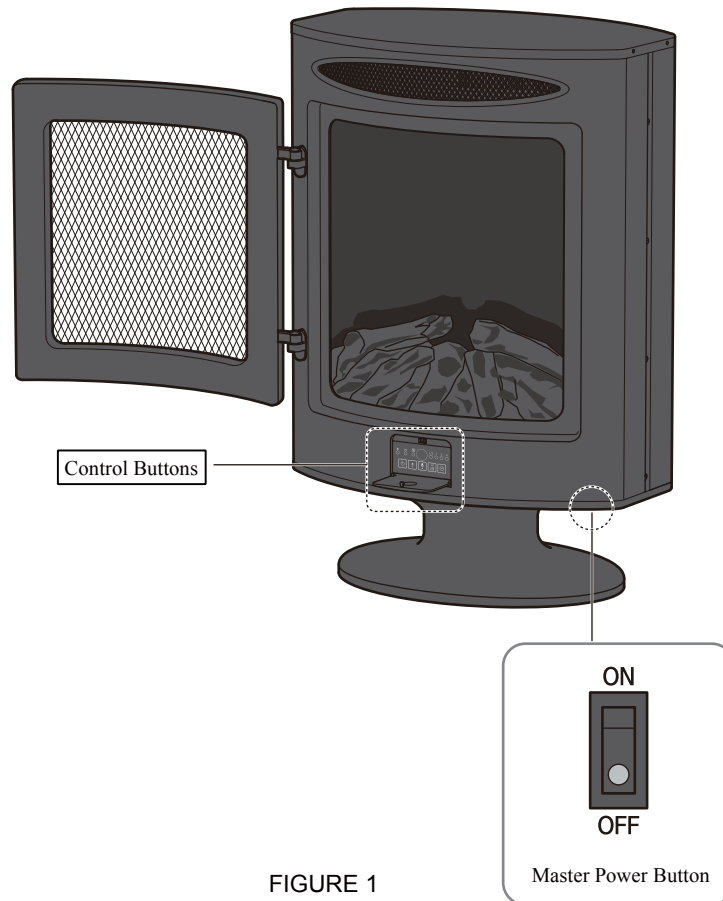

FIGURE 1

### CARE AND CLEANING OR MAINTENANCE

Turn heater OFF and unplug from electrical outlet before any cleaning or maintenance is performed.

Keep combustible materials, such as furniture, pillows, bedding, papers, clothing, and curtains at least 3 feet away from fireplace.

Use a vacuum or duster to keep heat and vent area from dust and dirt. The exterior of the fireplace should be cleaned with a damp cloth or duster. Do not use abrasive cleaners or liquid sprays.

Warning: Any other servicing should be performed by an authorized service representative.

## CONTROL BUTTONS/FUNCTIONS

The manual controls are located on the bottom of the fireplace.  
You have the following controls:

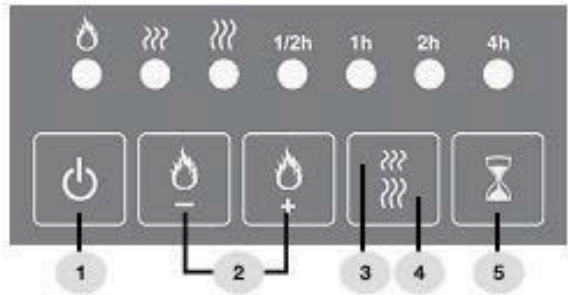

1. Power ON/OFF: Power to the unit
2. Flame brightness controls: Allows you to adjust the flame to suit your mood. Press to increase flame brightness and to decrease flame brightness. You must press the button several times to see the full flame effect.

3. Low heat: 800 watts

4. High heat: 1500 watts

Please note: The heater touch panel control must be pressed 2 times to achieve high heat.

5. Heater Timer: Allows you to leave your heater on while you sleep with an automatic timer for shut off. You can set your heater to be on for 1/2 hour increments starting at a 1/2 hour up to a maximum of 7-1/2 hours—press once for each 1/2 hour increment. After you reach 7-1/2 hours the next press will shut off the feature.

### OPERATING BY REMOTE CONTROL

1. Plug in your electric fireplace.
2. Make sure the main power ON/OFF switch is ON! The remote control will NOT work if the main power switch is OFF.
3. When operating the remote control, it must be pointed towards the front of the unit.
4. The ON/OFF button at the below right of the remote is the main ON/OFF power button (Figure 5). Pressing this button activates the power to the unit.
5. Press the button to cycle through LO, HI and OFF.
6. To adjust the flame height and ember bed brightness, press the “” or “” buttons. To increase the flame height and ember bed brightness, press the “” button. To decrease the flame height and ember bed brightness, the “” button. There are five levels of flame effects.
7. Press the “” button to set timer.
8. To turn off the fireplace, press the ON/OFF button once. NOTICE: This remote control must remain within 8 meters or 26 feet of the fireplace to be effective.



Remote Control For  
Electric Fireplace

## MAINTENANCE

**WARNING:** Before attempting to perform any maintenance on this appliance, turn all controls to the "OFF" position and unplug the heater. Allow the appliance to be "OFF" for at least 10 minutes before performing any maintenance in order to allow all components to cool properly.

### **Flame effect/Light bulb replacement:**

Allow the electric fireplace insert to cool before attempting to replace light bulbs. The flame effect on this electric fireplace insert is created by illuminating(2) clear 120V, 40watt E-12(small base, chandelier candle type)light bulbs. The life of the light bulbs will depend on how often the fireplace is used. Do not use light bulbs that exceed 40 watts per bulb.

1. Turn power to off and unplug insert from electrical outlet before changing light bulbs.
2. Slide fireplace mantel away from wall to gain access to back of fireplace.
3. Locate access panel on back of insert.
4. Using a Phillips screwdriver, remove screws in access panel. Open door and replace light bulbs as necessary. It is recommended that both bulbs be replaced at the same time.
5. Follow steps 1 through 4 in reverse order to reinstall access panel.

**NOTE:** We do not supply replacement light bulbs. They can be purchased at many home centers or hardware stores.

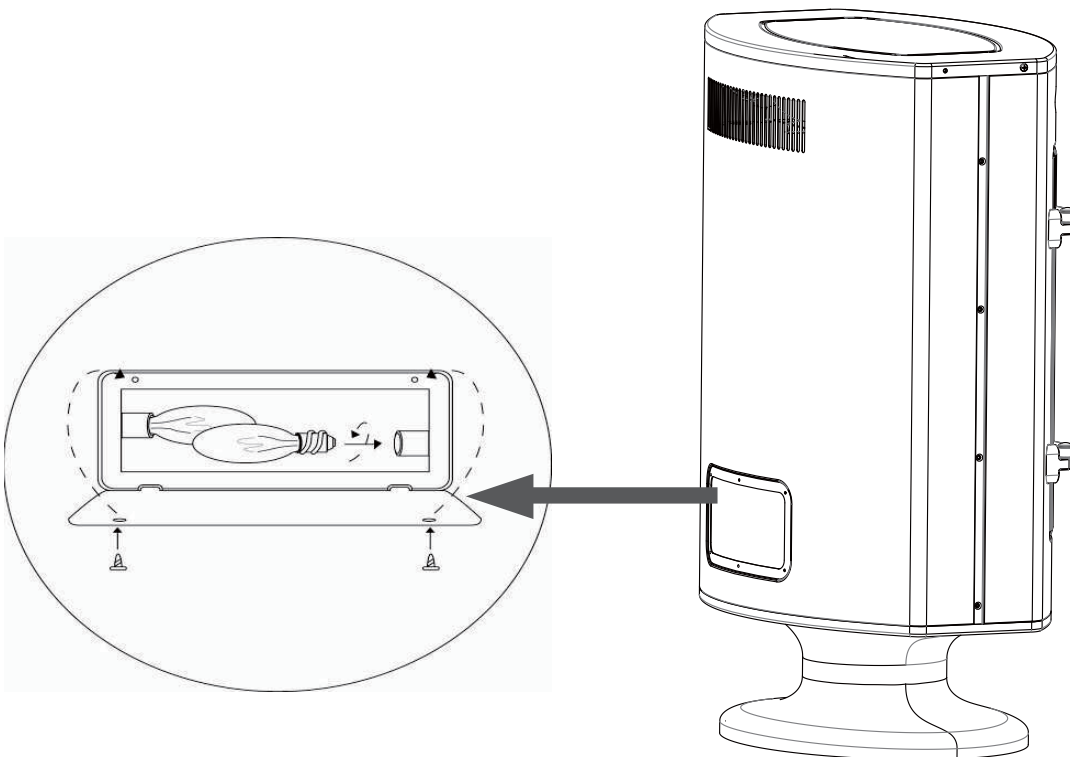



### **Care and maintenance:**

Turn heater OFF and unplug from electrical outlet before any cleaning or maintenance is performed.

Keep combustible materials such as furniture, pillows, bedding, papers, clothing, and curtains at least 3feet (0.9meter) away from fireplace.

Use a vacuum or duster to keep heat and vent area clean from dust and dirt. The exterior of the fireplace should be cleaned with a damp cloth or duster. Do not use abrasive cleaners or liquid sprays.



### **Warnings and cautions:**

**WARNING** To avoid electrical shock never open the back panel of the until the power has been turned off, and the insert unplugged.

**WARNING** Any electrical repairs to this electric fireplace, should only be performed by a qualified technician.

**WARNING** Any electrical wiring repairs should only be performed by qualified electrician, and also must comply with local building codes.

**WARNING** Discontinue use of this electric fireplace if any of the follow has occurred: Water damage, if insert has been dropped or dented, if power cord has become broken, if power cord becomes hot to touch, if unit smokes or smells like smoke.

**Note:** When the heat function is used for the first time, a slight odor may be present. This is normal and should not occur again unless heater is not used for extended periods of time and dust is allowed to accumulate on heater element.

## **TROUBLE SHOOTING**

---

**WARNING: Turn off the appliance, unplug and let cool for at least 10 minutes before attempting to service. Only a qualified professional should attempt to service or repair the appliance.**

| <b>PROBLEM</b>   | <b>POSSIBLE CAUSE</b>            | <b>CORRECTIVE ACTION</b>                              |
|--|----------------------------------|---|
| 1.No power, no indicator lights  | Insert was not plugged in        | Make sure that power cord is plugged into 120V outlet |
| 2.No power, no indicator lights  | No power at outlet               | Check circuit breaker or fuse                         |
| 3.Power indicator lights come on, logs will not glow and no flame effect | Broken or burned out light bulbs | Follow instructions for replacing light bulbs         |
| 4.Log glow, but no flame   | Flame spinner disconnected       | Call customer service for instructions                |
| 5.Flame and logs glow, but no heat                                       | Heater switch is off             | Push heater button. Indicator light will come on      |
| 6.Heater and /or flame turn off while operating                          | Timer function may been on       | Push On/Off button to reset                           |

# IMPORTANT

For questions, concerns or problems with our product please email our customer service department:

**customercare@jrhome.com**

DATED PROOF OF PURCHASE REQUIRED FOR WARRANTY SERVICE

Si vous éprouvez des difficultés ou si vous avez des questions ou des préoccupations, prière de faire parvenir un courriel à notre service à la clientèle

**customercare@jrhome.com**

UNE PREUVE D'ACHAT DATÉE EST REQUISE POUR SE PRÉVALOIR DE LA GARANTIE.

## WARRANTY

This product is inspected, tested and carefully packaged to minimize the chance of damage during shipment. If a part (excluding light bulbs, glass and fuses\*) within one year from the date of purchase proves to be defective in material or fabrication under normal use, the part will be repaired or replaced. The Company's obligation under the warranty is to replace or repair defective parts at our discretion. Any expenses or damage resulting from the installation, removal or transportation of the product will be the responsibility of the owner and are not covered by this warranty. The owner assumes all other risks arising from the use or misuse of the product. The warranty will be void if the product damage or failure is deemed by the Company to be caused by accident, alteration, misuse, abuse, incorrect installation or removal, or connection to an incorrect power source by the owner. The Company neither assumes, nor authorizes any person or entity to assume for it any obligation or liability associated with its products. Light bulbs and fuses are not covered under this warranty. If you have any questions regarding the warranty or service, please contact us at **customercare@jrhome.com**.

Customer Service :

JR Home Products

Unit 306 - 19100 Airport Way, Pitt Meadows, BC V3Y 0E2

Toll Free : 1-800-561-5550

E-mail : **customercare@jrhome.com**

**You MUST register your product within 30 days of purchase to receive warranty service.**

**Registration can be completed online at [www.jrhome.com](http://www.jrhome.com) or by mailing this form.**

## AVERTISSEMENT

Ce produit a été soigneusement inspecté, testé et emballé afin de minimiser les risques de dommages durant le transport. Si l'une des pièces (à l'exception des verres, des ampoules électriques et des fusibles\*) s'avère défectueuse au niveau de sa fabrication ou de ses matériaux dans l'année qui suit la date de l'achat suite à une utilisation normale, la pièce sera réparée ou remplacée. La compagnie est tenue de réparer ou remplacer les pièces défectueuses à sa discrétion, en vertu de la garantie. Tous frais ou dommage résultant de l'installation, du démantèlement ou du transport du produit demeurent la responsabilité du client et n'est pas couvert par cette garantie. Le client assume tout autre risque résultant de l'utilisation correcte ou fautive du produit. La garantie devient nulle si la compagnie détermine que le dommage ou le mauvais fonctionnement est causé par un accident, une modification, une mauvaise utilisation, un abus, une mauvaise installation ou un mauvais démantèlement ou un branchement à une source électrique inadéquate de la part du client. La compagnie n'est pas responsable et n'autorise quiconque, personne ou entité légale, à accepter de responsabilité ou obligation en son nom, en rapport avec ses produits. \* Les ampoules électriques et les fusibles ne sont pas couverts par cette garantie. Pour toute question au sujet de la garantie ou du service, contacter le service à la clientèle à : **customercare@jrhome.com**.

Service à la clientèle:

JR Home Products

Unit 306 - 19100 Airport Way, Pitt Meadows BC V3Y 0E2 Numéro

sans frais: 1-800-561-5550

Courriel: **customercare@jrhome.com**

**Vous DEVEZ enregistrer votre produit dans les 30 jours suivant l'achat pour bénéficier du service de garantie.**

**L'enregistrement sera complet une fois que vous aurez posté ce formulaire ou que vous serez inscrit en ligne.**



## Warranty Registration Information Form / Formulaire d'enregistrement de la garantie

Name / Nom : \_\_\_\_\_

Street / Adresse : \_\_\_\_\_

City / Ville : \_\_\_\_\_

Province / Province : \_\_\_\_\_

Postal Code / Code postal : \_\_\_\_\_

Daytime Phone # / No téléphone jour : \_\_\_\_\_

Evening Phone # / No téléphone soir : \_\_\_\_\_

E-Mail Address / Courriel : \_\_\_\_\_

Product/Produit : \_\_\_\_\_

Place of Purchase / Lieu de l'achat : \_\_\_\_\_

Date of Purchase / Date de l'achat : \_\_\_\_\_

Model # / No de modèle : \_\_\_\_\_

Serial # / Numéro de série : \_\_\_\_\_

You MUST register your product to receive warranty service.

For warranty service, contact J&R Home Products at the address, phone numbers listed below within 30 days of purchase. Be sure to have your sales receipt and original date of purchase. All warranty service will be coordinated by J&R Home Products service center.

Vous DEVEZ enregistrer votre produit pour vous prévaloir de la garantie.

Afin de faire valoir la garantie, communiquez avec J&R Home Products à l'adresse et aux numéros indiqués ci-dessous dans les 30 jours suivant la date d'achat. Ayez en main votre reçu et la date d'achat. Toutes les demandes liées aux garanties seront traitées par le centre de service de J&R Home Products.

Please mail to / Veuillez poster le tout à : Parts & Service Department, J&R Home Products Ltd. Unit 306 - 19100 Airport Way, Pitt Meadows, BC V3Y 0E2

120920