

# 2-IN-1 SWING

## USER AND ASSEMBLY MANUAL

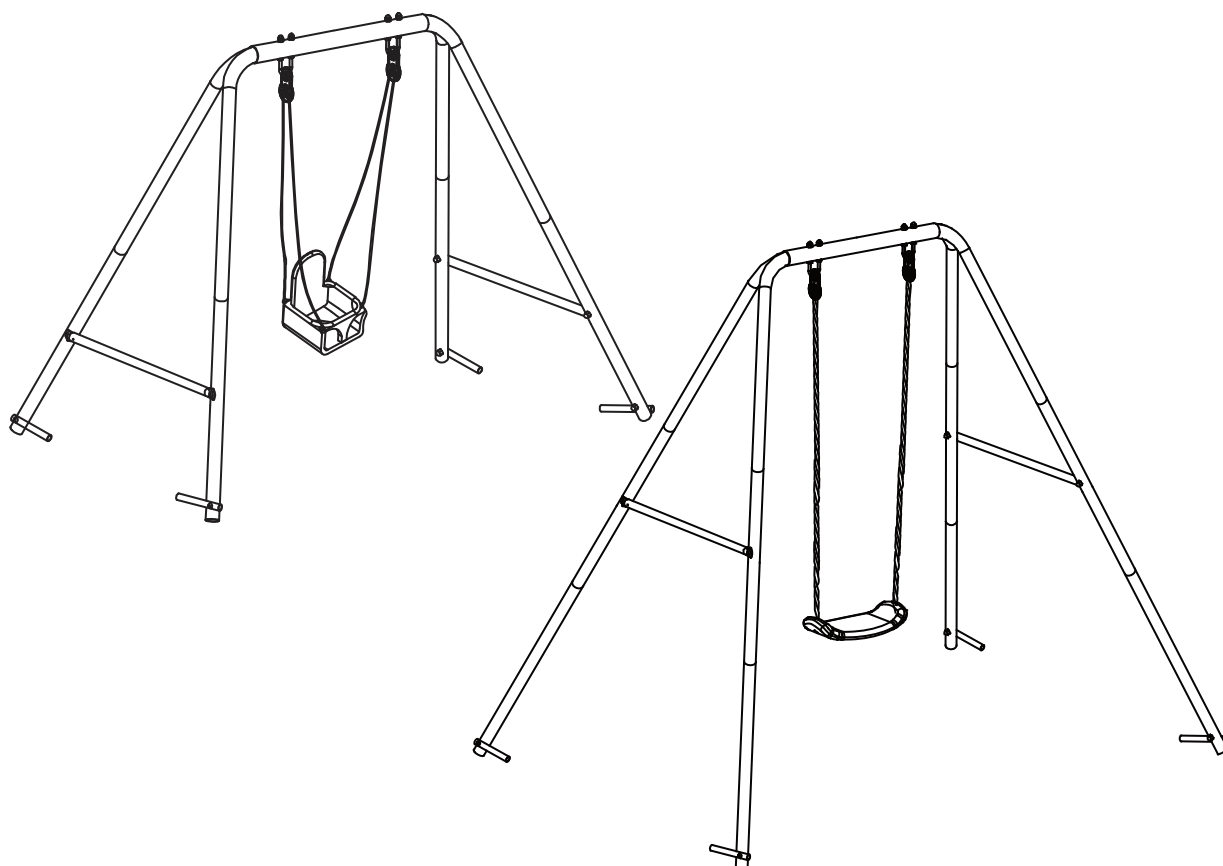

Tips : It will take 2 people around 45 mins to assemble this product.



### **WARNINGS!**

- Misuse and abuse of this product can result in injury.
- Read instructions before assembly or using this product. Retain Instructions.
- Always inspect product before use, checking for worn, defective or missing parts.
- The single swing is suitable for age 3-8 years with maximum user weight of 45 kg(99 lbs).
- The nursery swing is suitable for ages 12-36 months with maximum user weight of 25 kg(55 lbs).
- Do not stand on the swing.
- Adult supervision at all times.
- Only for outdoor and domestic use.

**Save this instruction manual for future reference**

For Customer Service, please call 1-866-632-1718 or visit [www.partsnservice.com](http://www.partsnservice.com)  
Monday – Friday 9:00 AM – 5:00 PM Eastern Time

Sportspower Ltd  
Level 20, Parkview Centre 7 Lau Li Street, Causeway Bay, Hong Kong

# Before you start...

- We suggest you spend some time reading this guide before following the simple step-by-step assembly instructions.
- Do not discard any of the packaging until you have checked that all parts and hardware are included. When discarding the packaging, please consider others and the environment.
- When assembling this product be aware of the safety of yourself and others.
- Because of the size of this product we suggest that you assemble it in the area intended for use.
- Some assembly steps will be easier with two people. Seek assistance when lifting large or heavy items.
- Assemble this product on a clean, flat and level surface e.g. the cardboard packaging.
- Keep any tools provided or spare fittings for future use. Only use the tools specified.
- Tighten all parts by hand first before tightening again with tools.
- Consider where the product is placed in relation to the sun to avoid overexposure to the heat, which may cause hazard such as dizziness.

**Your product is warranted against defects in material and workmanship. Extended warranty is also offered to those customers registering their products at [www.sportspowerltd.net](http://www.sportspowerltd.net) within 14 days from the date of purchase. Please refer to our warranty policy at the back of this manual for details.**

**If you experience any problems with your product, do not return to the store. For customer service, please call 1-866-632-1718 Monday-Friday 9:00am-5:00pm Eastern Time. If you are unable to reach us at this number for any reason, please visit [www.partsnservice.com](http://www.partsnservice.com)**

## SAFETY INFORMATION

**IMPORTANT** - Please read these instructions fully before assembly or use.

### Top Tips before you start













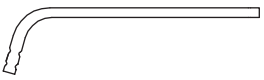

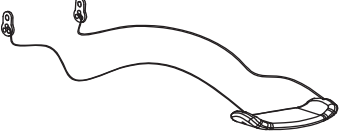
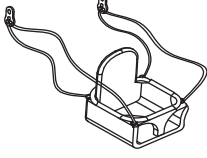

#### **WARNING. FOR DOMESTIC USE ONLY.**

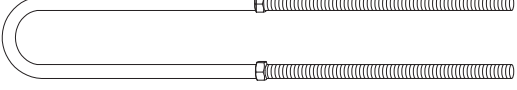
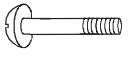
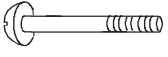
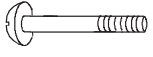
- Please check to ensure all parts are present before you start the assembly of this unit. If any missing parts, please properly store the product away and contact our customer service representatives for assistance.
- Assembly by adult(s) required. Do not allow children under 3 nearby during assembly to avoid choking hazard from small parts.
- Constant adult supervision is required during use of this product.
- At the start of assembly, do not tighten bolts/nuts completely so as to allow some possible adjustment. After all major components are assembled, go back over all bolts and nuts and properly tighten all of them before using this product.

### Read and follow all instructions

- The single swing is suitable for age 3-8 with maximum user weight of 45kg.
  - The nursery swing is suitable for ages 12-36 months with maximum user weight of 25kg.
  - The equipment is designed for outdoor domestic use only and is not permitted for hiring or commercial use.
  - Adult supervision is required at all times while the swing is in use. Never leave children unattended during play.
  - Do not use the equipment in any manner other than intended.
  - Please retain these instructions for future reference
  - The product should not be installed over concrete, asphalt or any other hard surfaces. The equipment should be placed on a level surfaces at least 2 m from any structure or obstruction such as a fence, garage, house, overhanging branches, laundry lines or electrical wires.
  - Do not use the equipment until it has been fully assembled and anchored, and all the components are properly secured. All the chains/ropes/cables cannot be looped back on themselves.
  - Never allow children to disembark from the play equipment whilst it is still in motion.
  - Ensure that children are not facing the sun whilst using the equipment.
  - Do not attach items to the equipment that are not specially designed for use with this product, including but not limited to cables, shipping ropes and chains as they may cause strangulation hazards.
  - Never allow children to walk too close to, in front of, behind or in between the equipment whilst in use, always keep children a safe distance from the product whilst in use.
  - Do not allow reckless playing, such as jumping off, standing on seats or climbing ropes.
  - Do not allow children to use when the swing seat is wet.
- Instruct children to avoid swinging the empty swing and not twist the swing chain or loop them over the top support bar since this may reduce the strength of the chain or rope.
  - Do not allow children to climb on the structure of the swing (eg legs, top bar, cross bars and other parts).
  - Instruct child to sit in the centre of the swing with their full weight in the center of the seat.
  - Ensure that children wear suitable clothing whilst using this equipment. Never allow children to wear loose clothing, neck ties, scarves, drawstrings or loose jewellery.
  - Please remove all packaging and packing tags/ wires before allowing your child to use. Please take note: As an extra precaution, check this product regularly for signs of wear or damage.
  - Protective surfacing: One of the most important things you can do to reduce the likelihood of serious head injuries is to install **Shock-Absorbing Protective Surfacing (over the ground)** under and around your play equipment. We recommend you use loose-fill materials such as wood mulch/chips, engineered wood fibre, shredded/recycled rubber mulch or sand gravel. The surfacing will also compact, displace, and settle, and should be periodically refilled. Carpeting and thin mats are generally not adequate protective surfacing, check and maintain the depth of the loose-fill surfacing material. Maintain the right amount of loose-fill material. Do not install loose fill surfacing over hard surfaces such as concrete or asphalt.

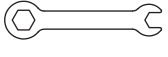
# CONTENTS

<p><b>1</b> x1 Beam</p> 	<p><b>2</b> x2 Leg Tube</p> 	<p><b>3</b> x2 Leg Tube</p> 	<p><b>4</b> x4 Leg Tube</p> 	
<p><b>5</b> x2 Rail</p> 	<p><b>6</b> x4 Leg Tube</p> 	<p><b>7</b> x4 Anchor</p> 	<p><b>8</b> x1 Single Swing Seat</p> 	
<p><b>9</b> x1 Nursery Swing Seat</p> 	<p><b>10</b> x4 Plastic Cap</p> 	<p><b>A</b> x2 (M8)</p> 	<p><b>B</b> x8 (M6x38mm)</p> 	
<p><b>C</b> x4 (M6x53mm)</p> 	<p><b>D</b> x4 (M6x42mm)</p> 	<p><b>E</b> x8 (Φ8.5 x Φ19mm)</p> 	<p><b>F</b> x32 (Φ6.5 x Φ14mm)</p> 	<p><b>H</b> x4 (Φ8.5 x Φ13.5mm)</p> 
<p><b>I</b> x16 (Φ6.5 x Φ10mm)</p> 	<p><b>J</b> x4 (M8)</p> 	<p><b>K</b> x16 (M6)</p> 	<p><b>L</b> x1 (10&amp;13mm)</p> 	<p><b>M</b> x1 (4mm)</p> 

## ASSEMBLY

### step 1

- Insert Legs (2) and (3) into Beam (1) as shown in FIGURE1.
- Please note the order of Legs (2) and (3) need to be inverse on the two sides of the beam.

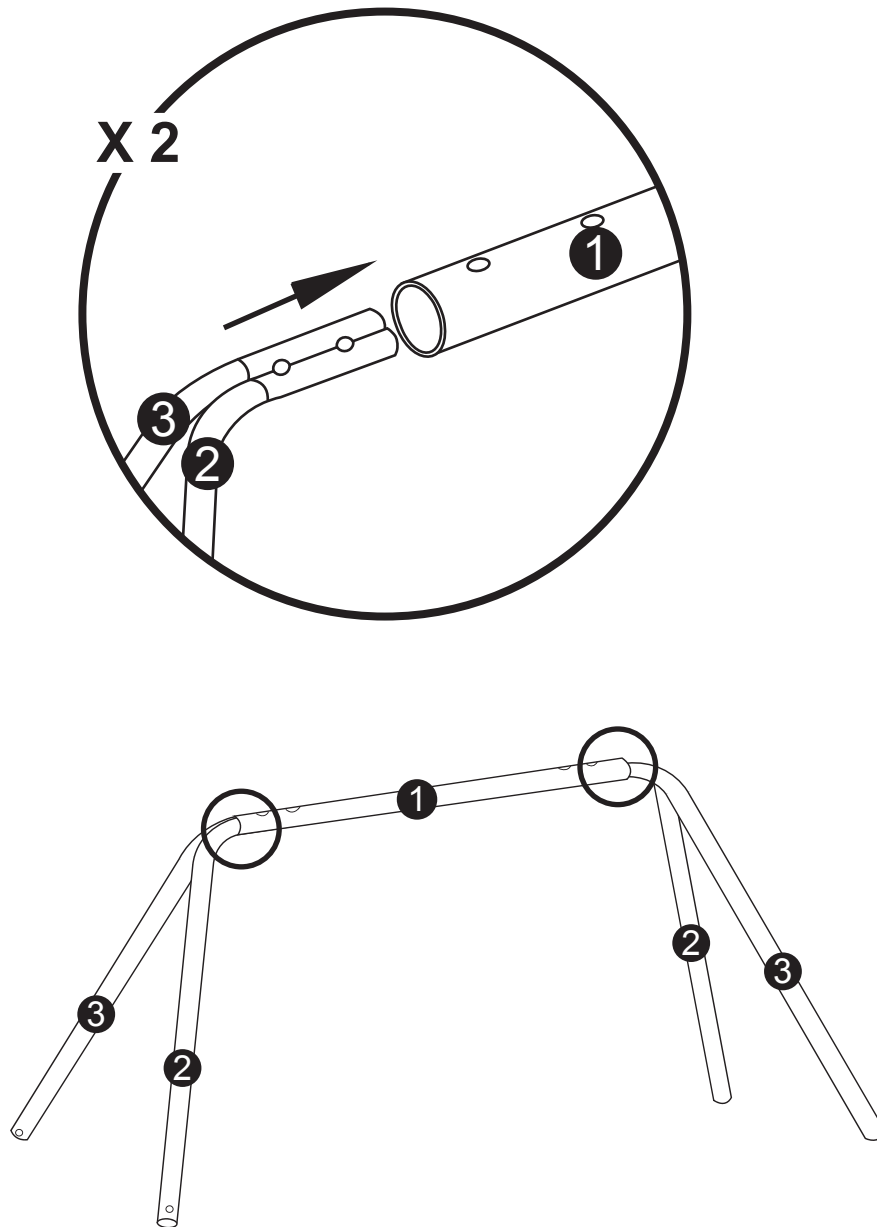

FIGURE 1

# ASSEMBLY

## step 2

- Insert Legs (4) into (2) and (3).
- Secure with B,F,I and K in the sequence shown in FIGURE 2.

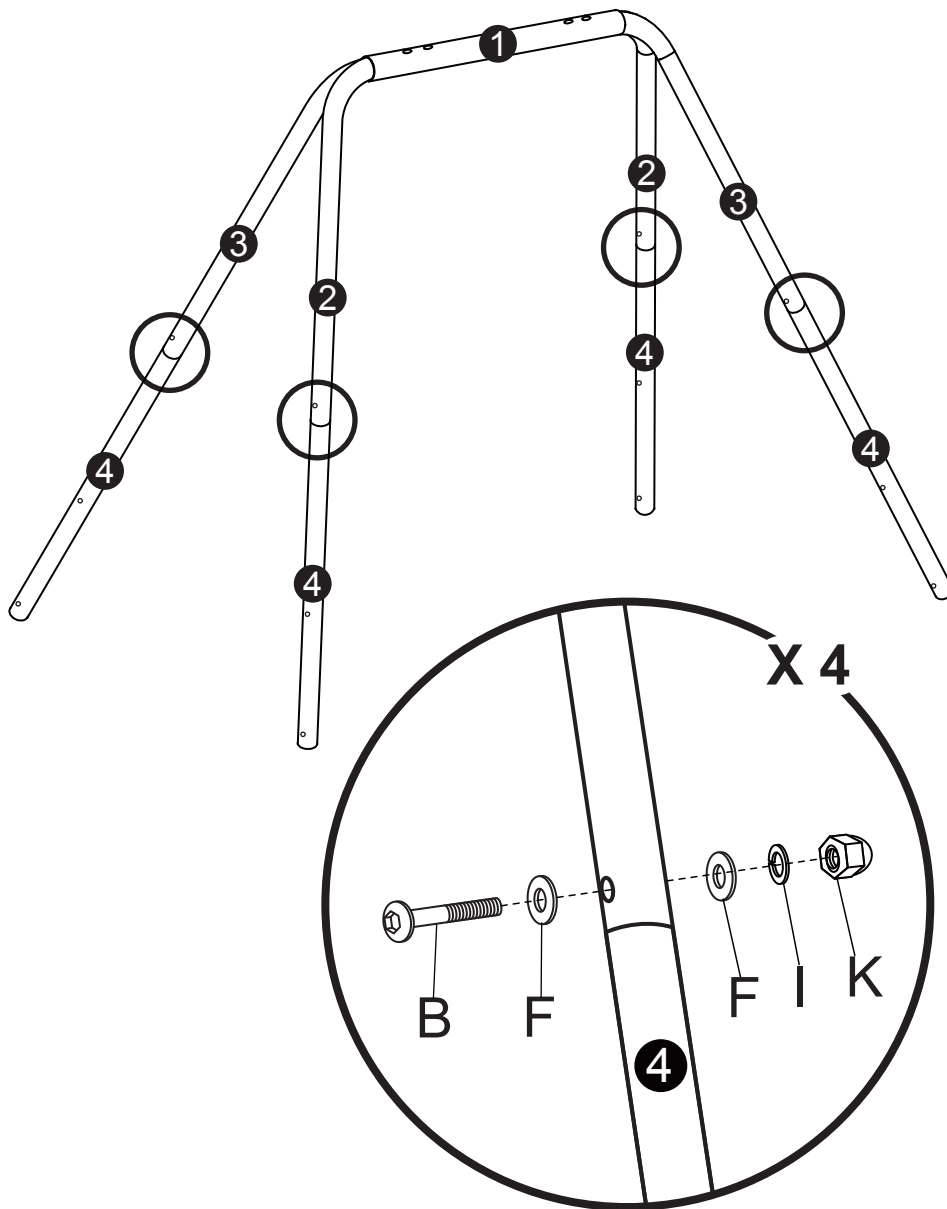
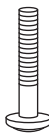





FIGURE 2

			
x 4	x 8	x 4	x 4
B	F	I	K

# ASSEMBLY

## step 3

- Attach Plastic Cap (10) to each side of Rail (5) Secure Rail to Legs (4) on both sides of the swing using D,F,I and K in the sequence shown in FIGURE 3.

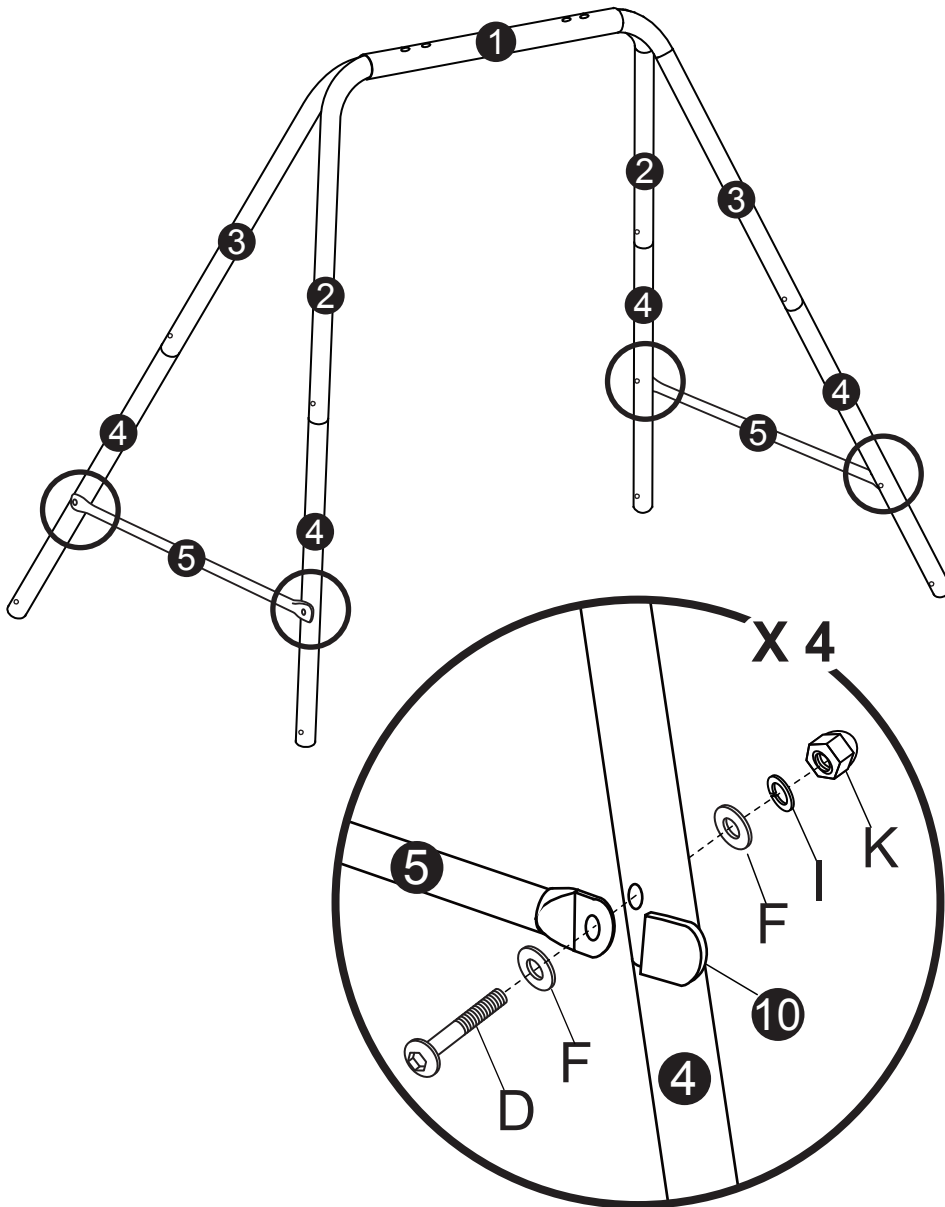
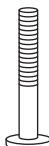





FIGURE 3

			
x 4	x 8	x 4	x 4
D	F	I	K

# ASSEMBLY

## step 4

### For Nursery Swing Seat (See steps 6 and 7 for Single Swing Seat)

- Secure the swing to Beam (1) using A, E, H, and J in the sequence shown in FIGURE 4.

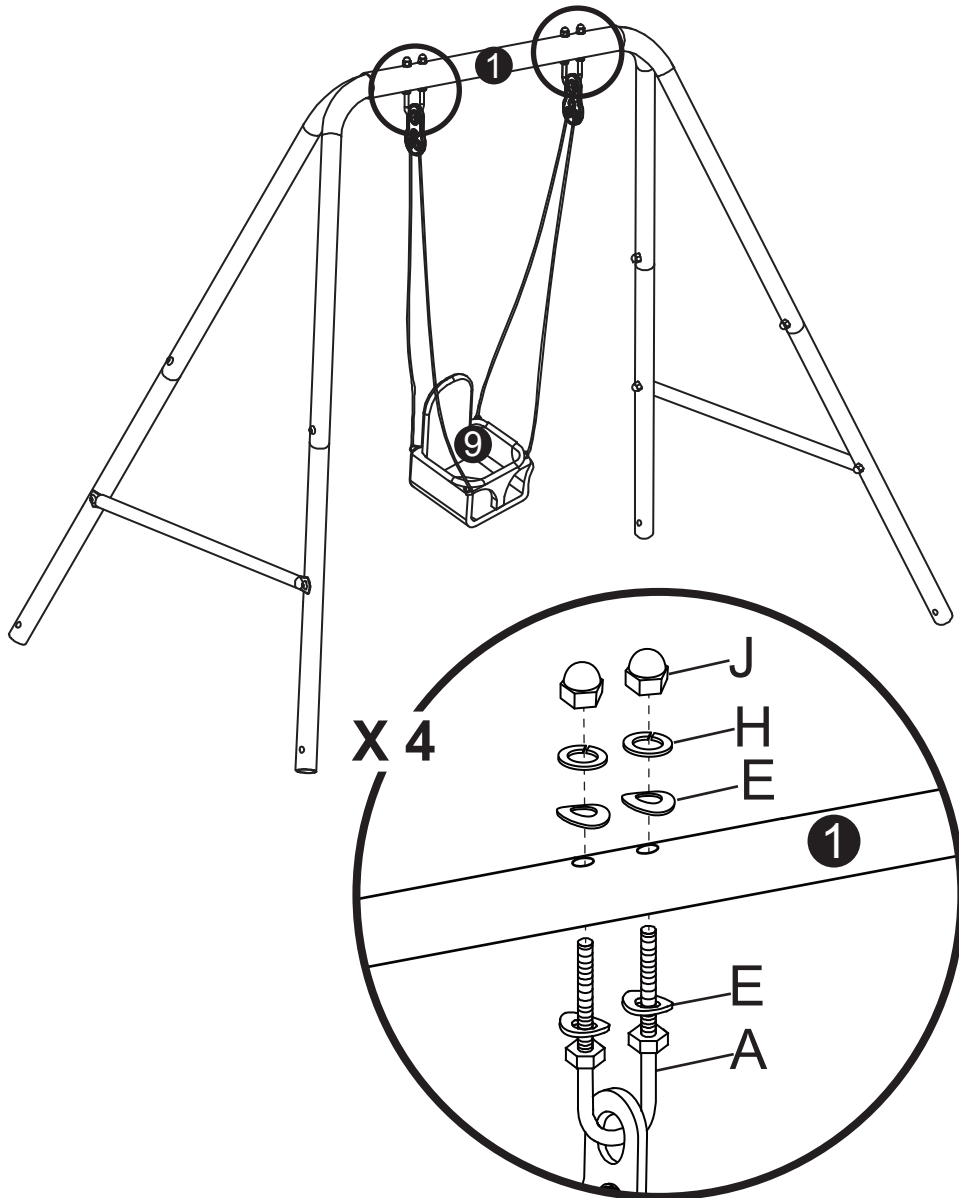
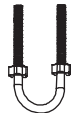





FIGURE 4

			
x 2	x 8	x 4	x 4
A	E	H	J



## ASSEMBLY

### step 5 For Nursery Swing Seat (See steps 6 and 7 for Single Swing Seat)

Note: Lock the seat belt tightly over the child shown in FIGURE 5.

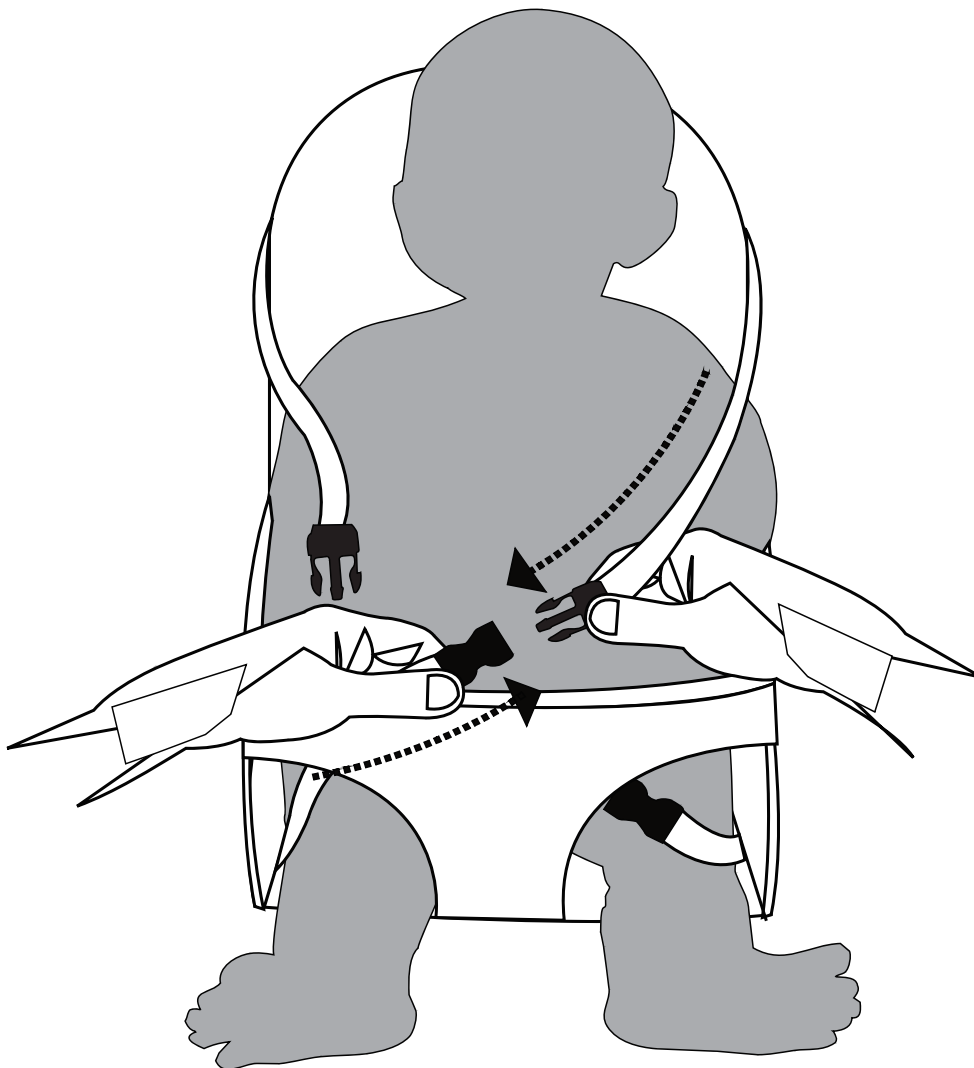

FIGURE 5



#### **WARNING!**

CONSTANT ADULT SUPERVISION REQUIRED AT ALL TIMES DURING USE.

# ASSEMBLY

## step 6 For Single Swing Seat

- Attach Legs (6) to (4) using B,F,I and K in the sequence shown in FIGURE 6.

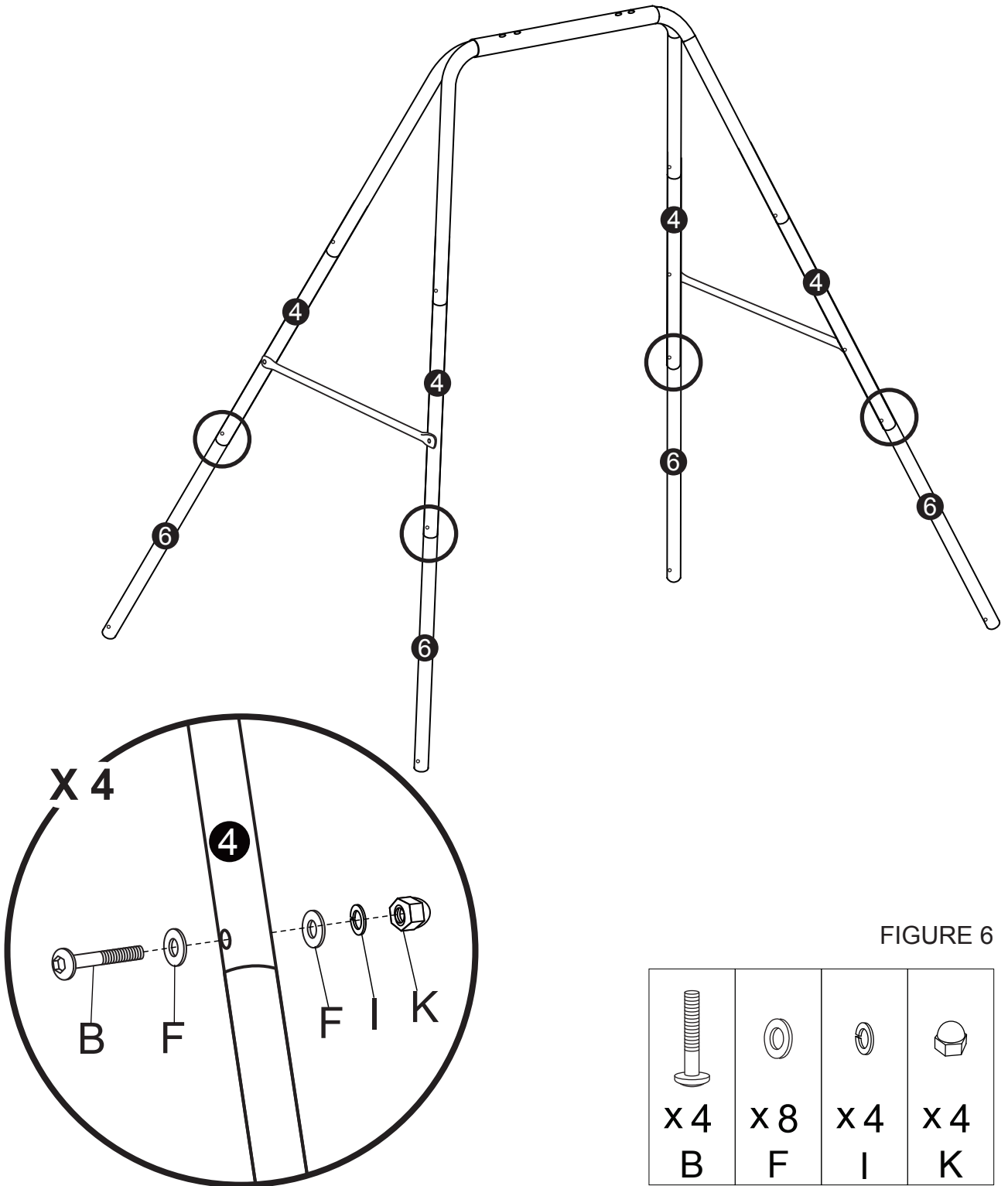

FIGURE 6

# ASSEMBLY

## step 7 For Single Swing Seat

- Secure the swing to Beam (1) using A, E, H and J in the sequence shown in FIGURE 7.

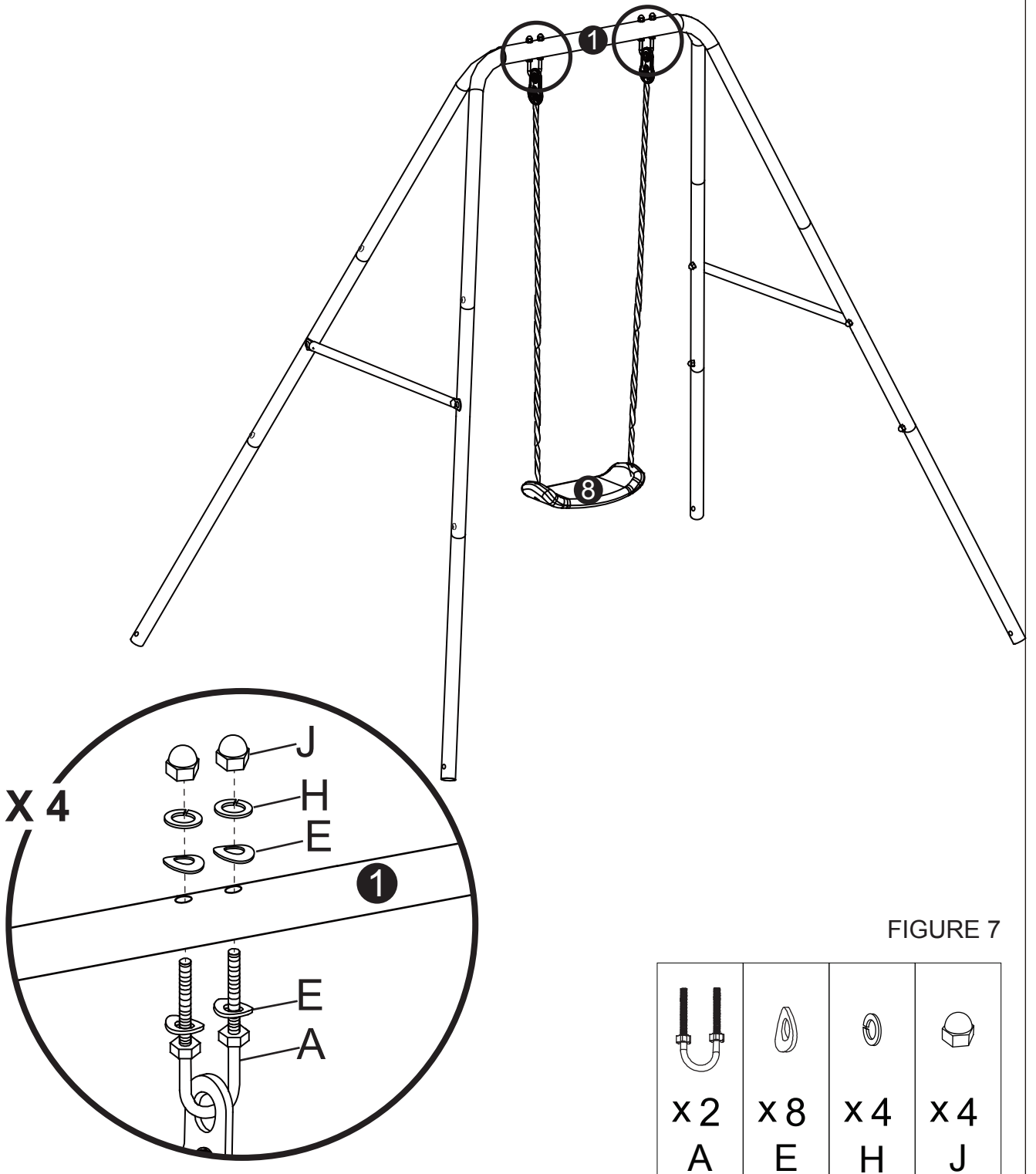

FIGURE 7

# ASSEMBLY

## step 8 For Nursery and Single Swing Seat

- Attach Anchor (7) to the base of all four Legs (6) using C, F, I and K in the sequence shown in FIGURE 7.

**IMPORTANT: AFTER COMPLETING ALL THE STEPS, GO OVER THE ENTIRE UNIT AND TIGHTEN ALL BOLTS BEFORE ALLOWING CHILDREN TO USE.**

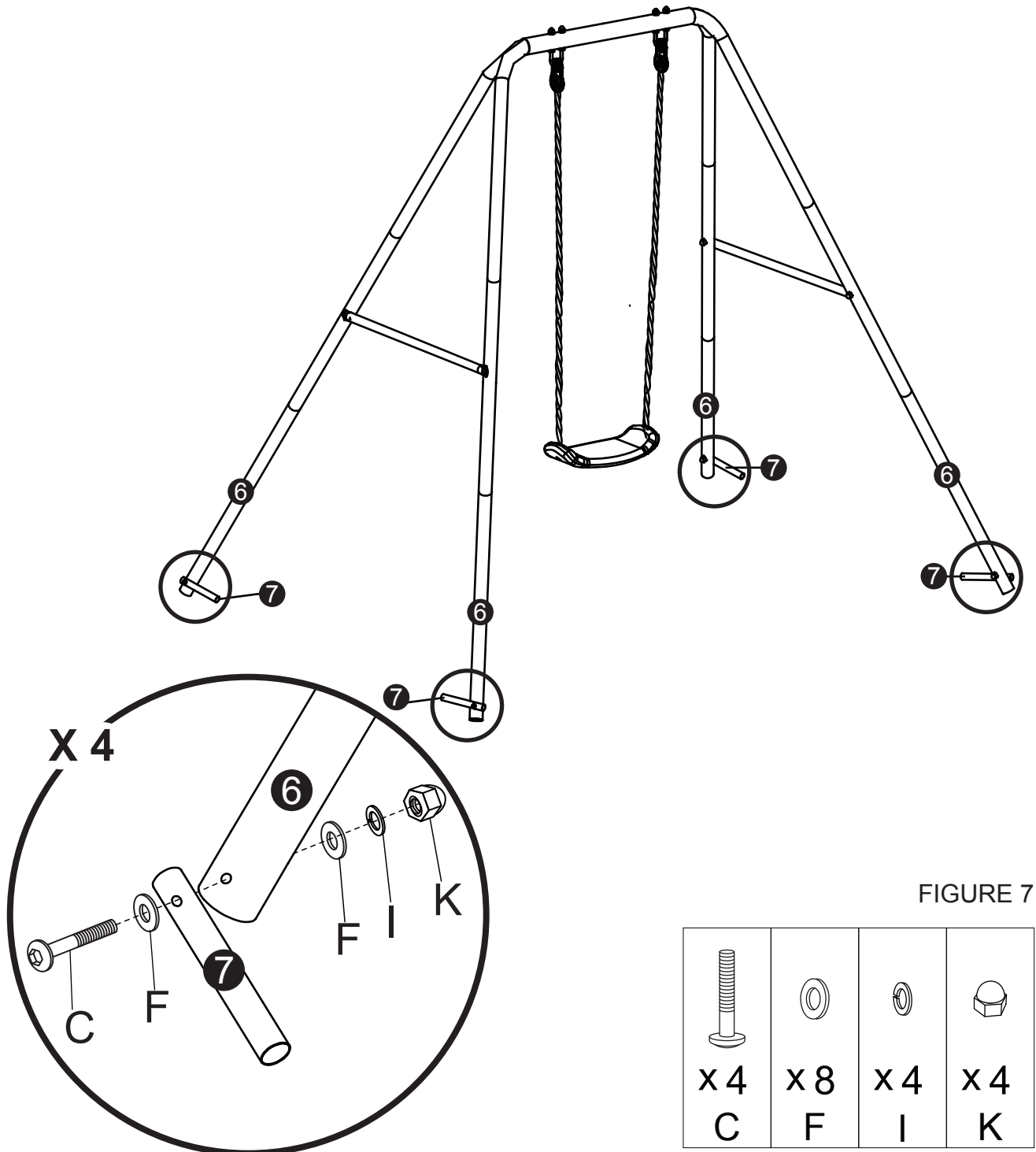
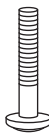





FIGURE 7

			
x 4	x 8	x 4	x 4
C	F	I	K

## ASSEMBLY

### step 9 For Nursery and Single Swing Seat

- Position the anchors at 45 degree angle and secure them fully into the ground until the leg of the swing is standing flat and stable on the ground.

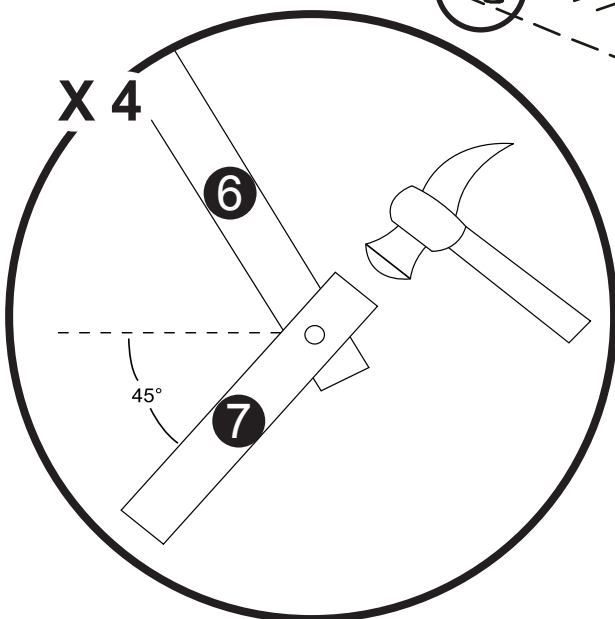
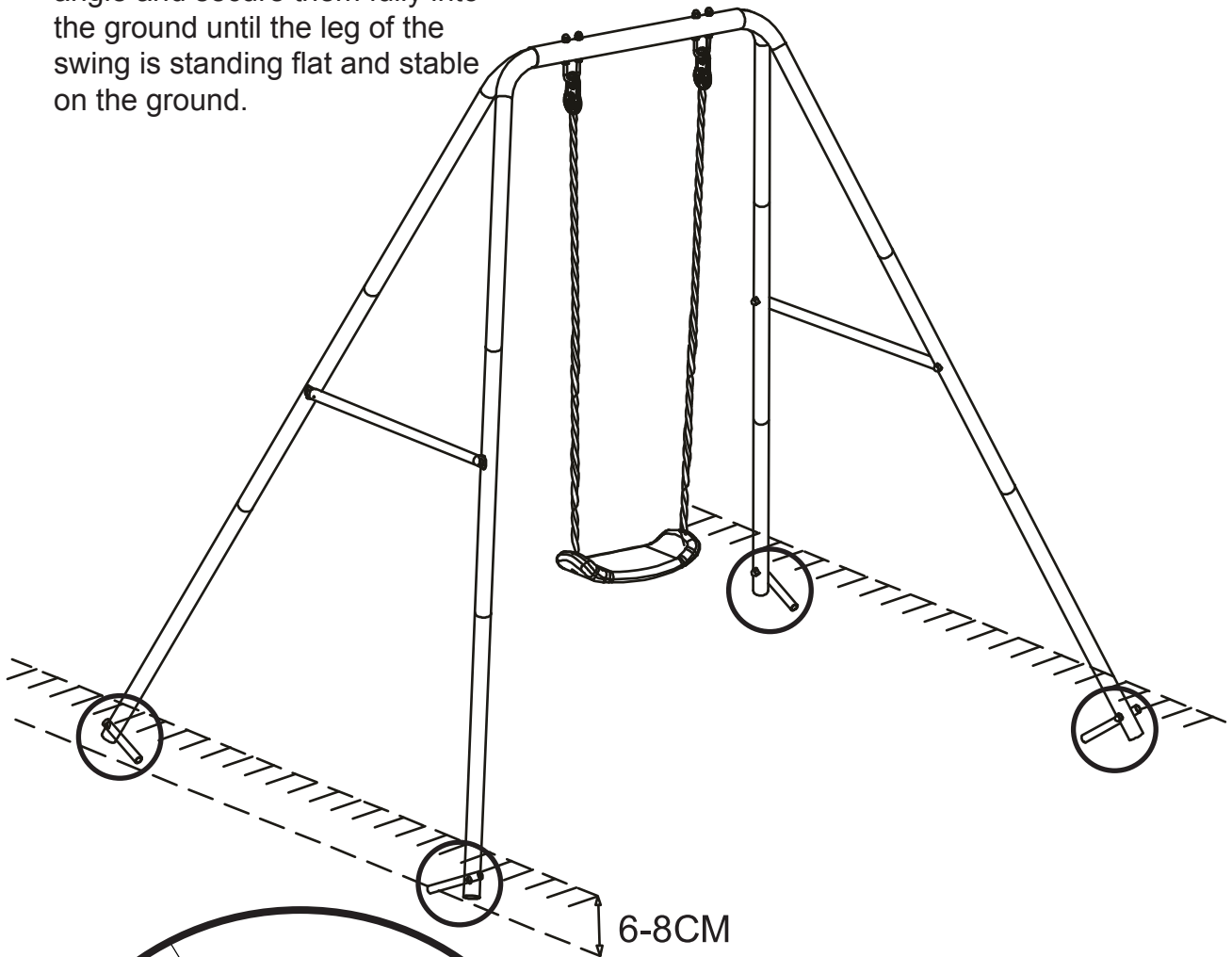

## ASSEMBLY

### step 10

#### SEAT ADJUSTABLE GUIDE

THE LENGTH OF THE ROPE IS ADJUSTABLE FOR THE HEIGHT OF THE CHILD THROUGH THE SEAT CONNECTOR.

TO ADJUST, LOOSEN THE KNOT ON THE SEAT CONNECTOR, PULL ROPE THROUGH THE HOLES AND TIGHTEN AGAIN.

MAKE SURE THAT THE KNOTS ARE TIGHT AND THAT BOTH ROPES ARE ADJUSTED SO THAT THE SEAT IS HORIZONTAL.

**IMPORTANT: MINIMUM CLEARANCE BETWEEN THE FOOTREST/SEAT AND THE GROUND SHOULD BE 35 CM.**

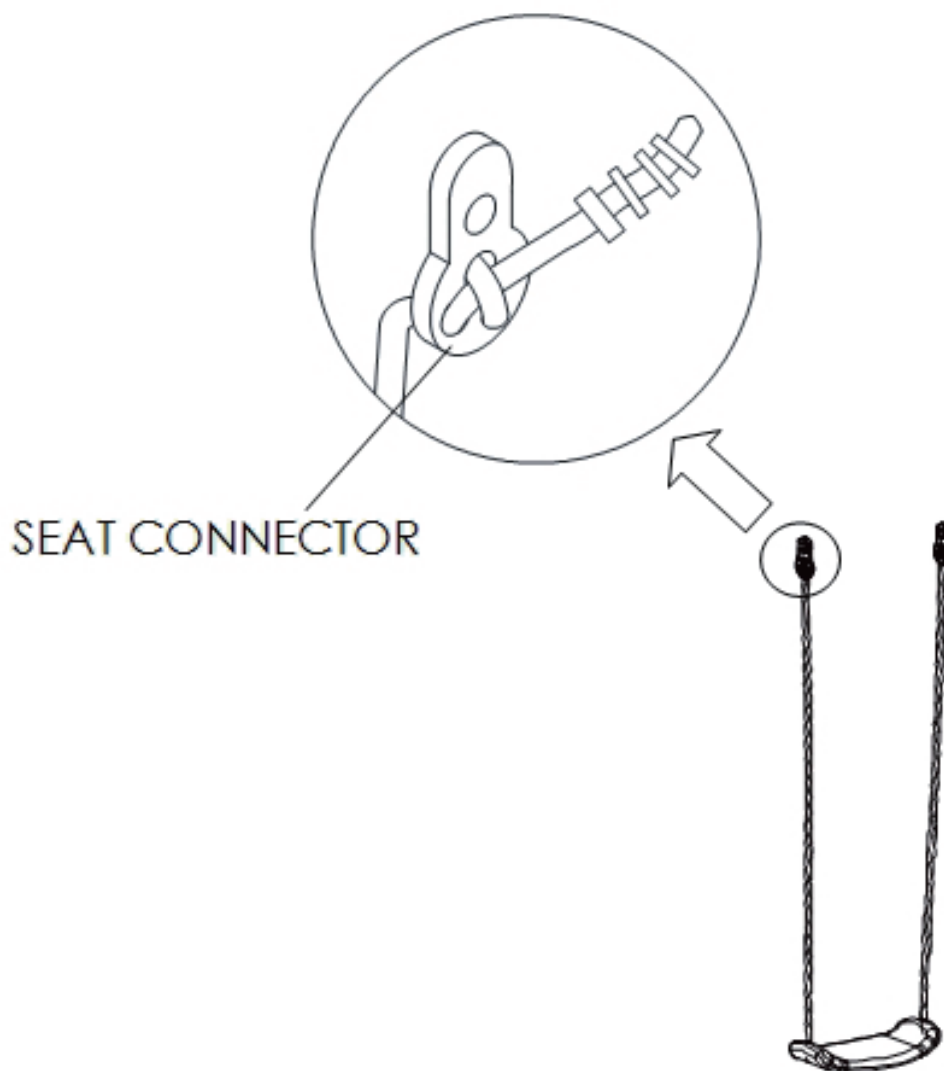

## CARE AND MAINTENANCE

### General

This 2-in-1 Swing was designed manufactured with quality materials and craftsmanship. If correct care and maintenance is provided, it will provide users with years of exercise, fun and enjoyment.

### Inspect regularly for:

- CHECK ALL NUTS AND BOLTS TWICE MONTHLY DURING THE USAGE SEASON AND TIGHTEN AS REQUIRED. IT IS PARTICULARLY IMPORTANT THAT THIS PROCEDURE BE FOLLOWED AT THE BEGINNING OF EACH SEASON.
- Never use pliers to tighten up screws –these can cause damage to both the paintwork and the special anti-corrosion plating.
- Immediately remove and replace any items that appear to be weak or broken. Contact Customer Support for replacement parts.
- Lubricate all metallic moving parts monthly during the usage season. Applying a light coat of automobile wax to all metal tubing surfaces will help protect your unit and add to its longevity. Sand any rusted areas of the metal tubing and repaint using a non-lead based paint.
- Remove plastic seats and store indoors, or do not use when the temperature drops below 32°F/0°C.
- Check unit for scuffs, burrs, sharp edges and any other defects that may occur from assembly, abuse, shipping or everyday use. Burrs and sharp edges may be filed down until smooth and covered with duct tape if necessary.
- To help maintain the products appearance, occasionally clean the seats and metal framework with a damp cloth lightly – but DO NOT use abrasive chemical cleaners.
- When the time comes to disassemble and dispose of this product, please completely disassemble the unit and discard of it in a safe place and manner so as not to present any hazard to any individual. It is important to check and maintain the main parts at regular intervals.If these checks are not carried out,the toy could overturn or otherwise become a hazard.Whenever practical,the instructions shall also be affixed to the toy.

**IMPORTANT!KEEP FOR FUTURE REFERENCE.**

### WARNING!

- Nursery Swing is suitable for children between ages 12-36 months with maximum weight of 25 kg(55 lbs).
- Single Swing is suitable for children between 3-8 years old with maximum weight of 45 kg(99 lbs).
- Do not allow more than one user at the same time.
- Constant adult supervision required at all times during use. Do not leave children unattended.
- For domestic use only. Not for rental or commercial use.
- Adult assembly required. Make sure to properly dispose of all packaging material and do not allow children nearby during assembly due to long cord(s)- strangulation hazard!

## PRODUCT WARRANTY

Sportspower Ltd warrants its products to be free from defects in material and workmanship under normal use and service conditions for ninety (90) days after the date of purchase. Extended warranty from 90 to 180 days will be offered to those customers registering their products at [www.sportspowerltd.net](http://www.sportspowerltd.net) within 14 days from the date of purchase. The frame is warranted for 12 months after the date of purchase.

This warranty coverage extends only to the original purchaser with a receipt and is non-transferable. All products for which a warranty claim is made must be received by SPORTSPOWER'S authorized service center, freight prepaid, and accompanied by sufficient proof of purchase during the warranty period.

This limited warranty does not cover our products which: fail due to (1) normal wear; (2) abuse and neglect; (3) improper maintenance; (4) unauthorized repairs or alterations or (5) are used for commercial or other income producing purposes or (6) accidents and misuse.

All warranty repairs must be authorized by SPORTSPOWER Customer Service before repairs are made.

**IMPORTANT: A missing part is not considered the same thing as a defective part or unit. If a part is missing, there is no need to return the entire unit to the store. In order to obtain fast replacement parts or service as provided by this warranty, please call the number below. Proof of purchase required.**

**For Customer Service, please call 1-866-632-1718 or visit [www.partsnservice.com](http://www.partsnservice.com)**

**Monday - Friday 9:00 AM - 5:00 PM Eastern Time**

Sportspower Ltd.

Level 20, Parkview Centre, 7 Lau Li Street, Causeway Bay, Hong Kong