

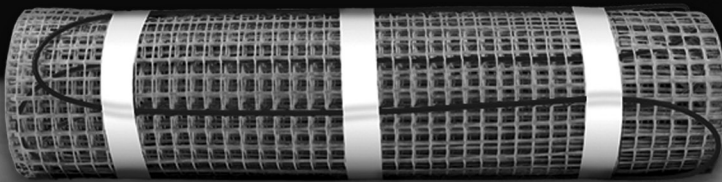

TempZone EasyMat™

Floor Heating
Installation Guide

Step-by-Step instructions on How to Install Your New WarmlyYours Electric Floor Warming



24/7 Installation Support | Lifetime Technical Assistance | Free Design Service

www.WarmlyYours.com | (800) 875-5285

IMPORTANT:

BEFORE STARTING YOUR FLOOR WARMING PROJECT, PLEASE REVIEW THESE IMPORTANT DO'S AND DON'TS



DON'T



NEVER cut the warming cable

NEVER shorten the warming mat

NEVER connect TWO (2) or more warming mats together in series

NEVER fold or position the warming cable so that it overlaps itself or other wires (this could cause dangerous overheating)

NEVER run a power lead or sensor wire across the warming cable

NEVER place built-in cabinets or other furniture with solid bases on top of the heated area of the floor (this could trap heat and cause dangerous overheating)

NEVER, when laying the system directly on top of a concrete subfloor, lay the warming cable over an expansion joint

NEVER run a warming cable in or through a wall

NEVER lay the warming system closer than 2" from a wall or another heat source

NEVER connect warming mat to the power supply before it is installed beneath the floor covering (this could cause dangerous overheating)

DO

ALWAYS when using timer, connect the system to a dedicated, GFCI protected, 15 or 20 Amp Circuit (depending on heating area)

ALWAYS test the warming system before, during and after installation

ALWAYS maintain consistent spacing when positioning the warming cable

ALWAYS make sure that your flooring type is compatible with the warming system

SYSTEM INSTALLATION

The installation process for a WarmlyYours floor warming system is similar to that of floor covering installation and is performed using many of the same tools. With a little care and conscientious observance of the installation instructions, a first time installer should have great success completing their floor warming project.

If you encounter any difficulties while installing your system, installation support is available 24/7 by calling (800) 875-5285.

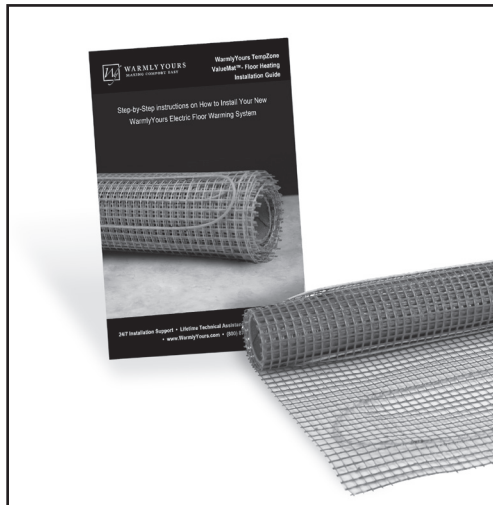

STEP 1: VERIFY CONTENTS OF YOUR FLOOR WARMING PACKAGE

Before beginning your installation project, check to make sure that your floor warming package contains the following items:

1. Floor Warming mat
2. Installation Guide & Warranty Registration

If any items are missing, please contact a WarmlyYours customer service representative at **(800) 875-5285** for expedited replacement.

⚠️ Note: *Never connect mat to the power supply before it is installed beneath the floor covering (this could cause dangerous overheating).*

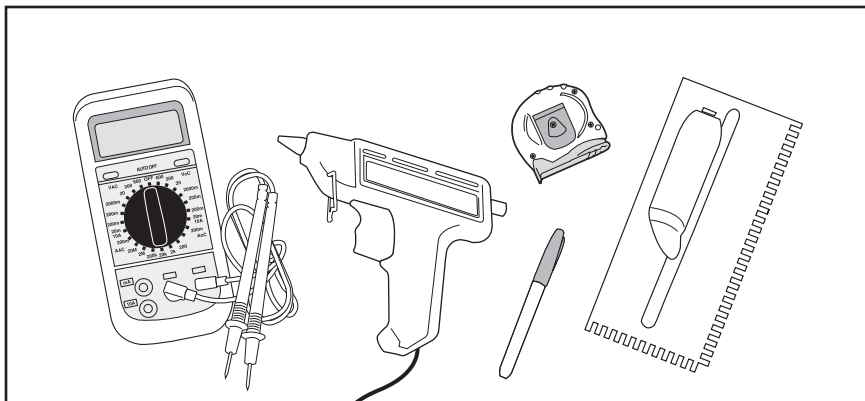

STEP 2: GATHER TOGETHER REQUIRED INSTALLATION TOOLS

The following materials are required to perform a floor warming system installation:

1. Digital Ohm Meter
2. Hot Glue Gun, Duct Tape or Staple Gun (for holding the system in place while working)
3. Broad Tip Permanent Marker and Tape Measure
4. 1/4", 3/8" or 1/2" Notched Trowel, Depending Upon Tile Size
5. Latex Modified Thinset Cement

STEP 3: ROUGH-IN ELECTRICAL WORK

The National Electric Code (NEC) recommends a dedicated circuit for all floor warming systems. Local codes may differ, so always consult with a qualified electrician first.

When installing a thermostat, use a 4" square, 2 1/8" deep electrical box with a single mud ring. Electrical boxes are typically placed at eye level (roughly 5' off the floor).

⚠ Note: A licensed, qualified electrician should perform the installation of the system thermostat or control device and final electrical hook-up. The installation requires an electrical conduit and a housing box.

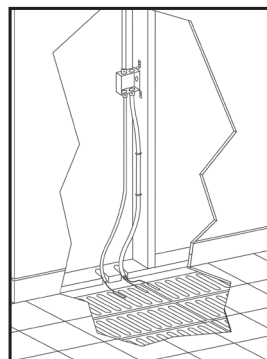

STEP 4: CHECK AND PREPARE THE SUBFLOOR

WarmlyYours floor warming systems may be installed over any subfloor that is approved for tile or stone application, including plywood, backer board and concrete slabs.

⚠ Note: While WarmlyYours systems provide up to 25% more heating power per square foot than the nearest competitor, the slab will always act as a “heat sink.” We suggest using Cerazorb® over a slab, between the cable and slab.



The subfloor should be carefully inspected to ensure that it is clean and free of sharp edges, nails and other materials that may damage the system’s warming cable. All debris should be removed, protrusions sanded flush and the floor thoroughly vacuumed before installation.

⚠ Note: If the subfloor is a concrete slab that contains an expansion joint, position the system so that it does not cross over the joint.

STEP 5: TEST POSITION YOUR SYSTEM ON THE SUBFLOOR BEFORE INSTALLING

You should test fit the warming system on the subfloor to determine where you would like to have the floor warmed for your personal comfort. See pages 8-10 for various layouts.

Tip 1: Locate placement of the system’s thermostat or control device and arrange the power leads accordingly. Power leads should run alongside the system and should never cross over or under the warming cable, or themselves.

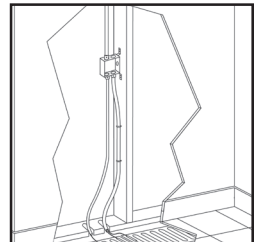

Tip 2: Use a permanent marker directly on the subfloor to indicate where to position the system. These marks will serve as a ready reference during final installation.

Tip 3: If multiple system mats are being installed in a single room, position each mat so that the warming cable or power leads do not cross over one another, and are within reach of the thermostat.

⚠ Note: Warming mats are never attached to each other in series. The power leads of each mat must return separately to the power source.

STEP 6: CHECK SYSTEM OHM READING PRIOR TO INSTALLING

Before installing a system, check the Ohm resistance between the two (2) power conductor wires to make sure that no breaks or shorts have occurred that could affect the system's future performance, and also test between the two (2) braided sheaths.

The Ohm reading should be within +/- 15% variance of the factory reading indicated on the UL label attached to the warming mat. If the reading is outside of this variance, contact a WarmlyYours representative at **(800) 875-5285** for assistance.

Tip 1: Check your Ohm meter to make sure that it contains fresh batteries and is properly set/calibrated to a scale setting of 0 - 200 prior to taking a reading.

Tip 2: Record Ohm readings in the chart provided on page 11 and keep handy for future reference.

Tip 3: Do not hold the wires with your hands, as this will affect your readings. (See diagram)

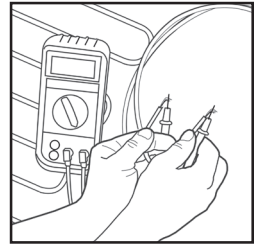

STEP 7: SECURE SYSTEM TO SUBFLOOR

1. Position the system on the clean and prepared subfloor. Run the power leads back to the power supply without crossing over the warming cable.

⚠ Note: *The yellow power lead wire is approximately 13' long and is generally considered the beginning of the warming mat. The white power lead is approximately 26' long and is generally considered the end of the mat. Either cable may be shortened or extended to reach the power supply, but as they are constructed like coaxial cables with a sheath around the core conductor, the sheath must be grounded at the control end.*

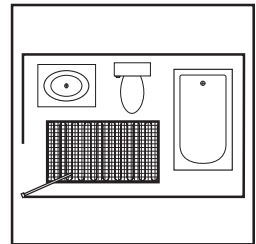

⚠ Note: *Whenever possible, lay the system with the warming cable down and the mesh backing up to protect the cable from any trowel nicks during tile or stone installation.*

2. If installing a thermostat or control device that includes a floor sensor, place the sensor head under the fiberglass mesh, 6" inside of the edge and center it precisely in the middle of the serpentine loop. Once positioned, hold the sensor in place with hot glue or duct tape to prevent it from moving during the remaining installation.

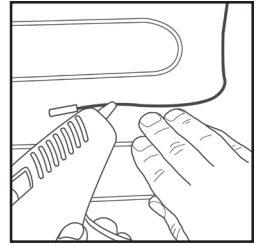

! *Note: The 7-Day Programmable Timer does not use a sensor.*

3. Likewise, once the system and power leads are in place, affix each to the subfloor using hot glue or duct tape.

! *Note: Hot glue will not harm the warming cable or power leads and may be used to hold them in place. If using a staple gun, apply staples through the fiberglass mesh only. Never staple near or directly over the warming cable or power leads.*

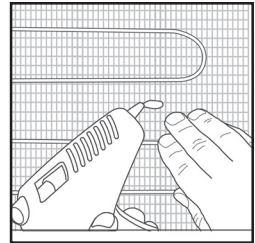

4. Once in place, we strongly recommend that you take photographs of the actual installation layout of your floor warming system. This will provide an accurate record should you undertake additional remodeling in the future, or in the unlikely event that some issue should arise with the installation.

STEP 8: COVER THE SYSTEM IN THINSET CEMENT

You are now ready to apply a thin, skim-coat layer of latex modified thinset cement over your warming system.

1. Use the flat edge of a trowel to carefully apply a thin skim-coat of thinset cement over the warming system and allow it to dry. Be careful not to nick the warming cable or power leads with the trowel.

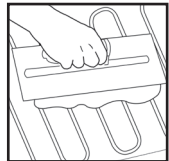

2. Once the thinset has thoroughly dried, install the new floor covering. We recommend a 1/4" or 3/8" notched trowel to assure sufficient coverage of thinset for the application of a tile or stone floor.

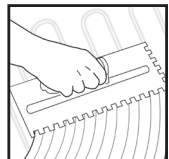

STEP 9: ELECTRICAL POWER HOOK-UP

When required by local codes, use a licensed and qualified electrician to perform the system's final electrical hook-up.

 *Note: Always connect the system to a dedicated, GFCI protected, Circuit.*

STEP 10: SYSTEM OPERATION

Before operating a new floor warming system, wait until the thinset cement used to lay the tile or stone floor has fully cured to the manufacturer's specifications (usually 2 to 14 days). Failure to do so can affect the thinset's curing process, causing it to become brittle and weakening its bonding characteristics.

 *Note: The timer can be "on" a maximum of 8 hours in any 24-hour period. Do not exceed more than 4 hours during any single use.*

STEP 11: WARRANTY REGISTRATION

Your new WarmlyYours floor warming system comes with a standard warranty and lifetime technical support. See pages 14 & 15 for entire warranty.

To activate your warranty, promptly fill out your warranty registration on-line at www.warmlyyours.com/h/warranty-register/.

BATHROOM AND POWDER ROOM LAYOUT EXAMPLES WITH 3'x2' & 3'x3' FLOOR WARMING SYSTEMS

Figure 1: 3'x2' EasyMat™ in Toilet area
5' 6" (168cm)

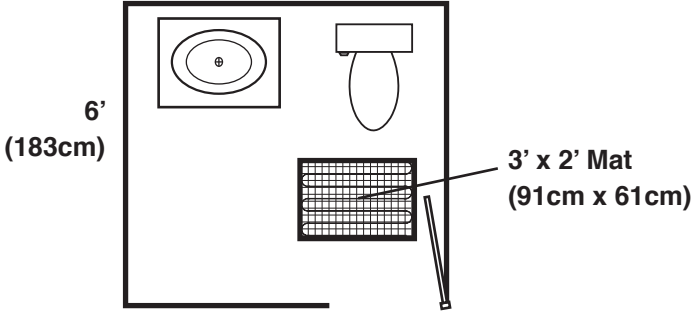

Figure 2: 3'x3' EasyMat™ by Shower
7' 2" (218cm)

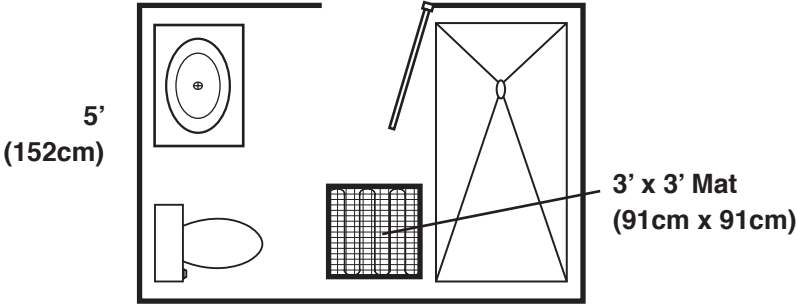
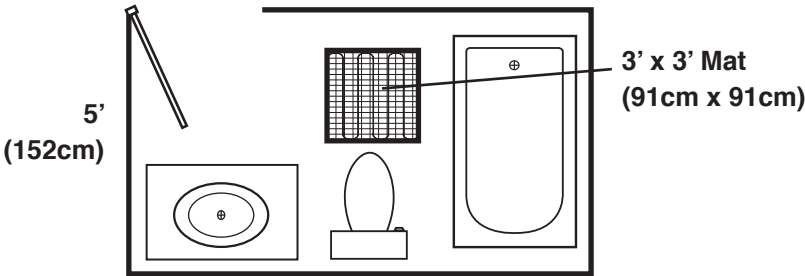

Figure 3: 3'x3' EasyMat™ by Tub
8' (244cm)



BATHROOM AND POWDER ROOM LAYOUT EXAMPLES WITH 3'x5' & 3'x6' FLOOR WARMING SYSTEMS

Figure 4: 3'x 5' EasyMat™ Tub and general coverage

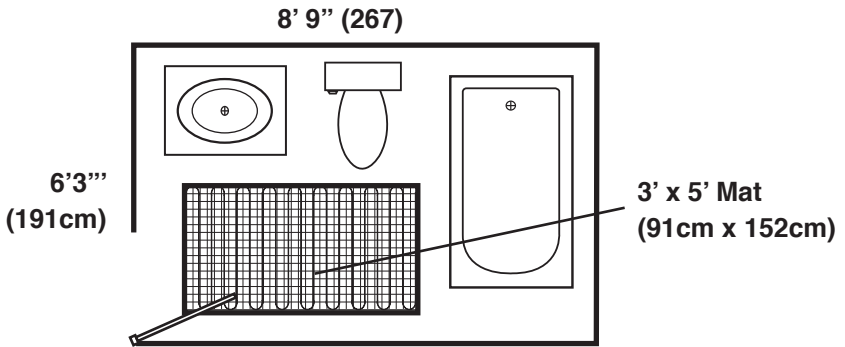

Figure 5: 3'x 6' EasyMat™ by Shower and general coverage

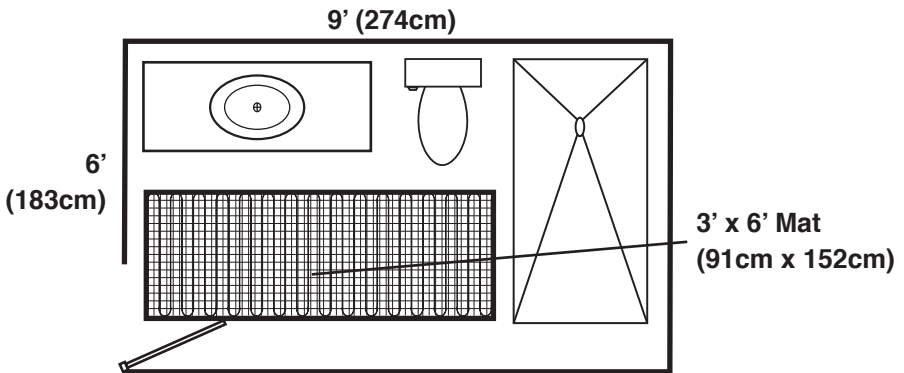
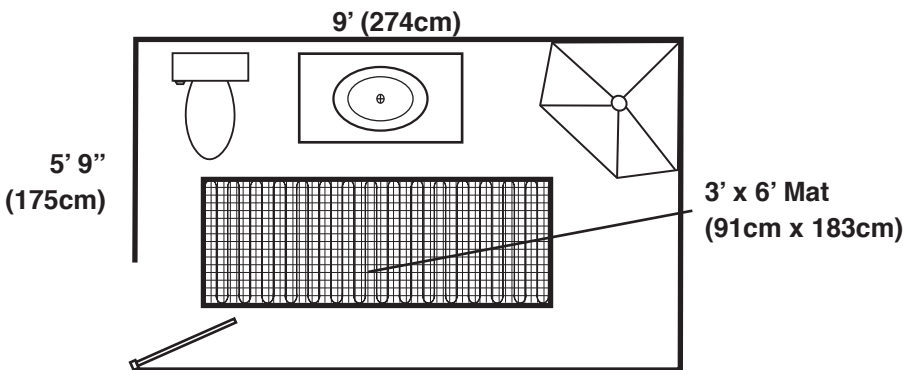

Figure 6: 3'x 6' EasyMat™ by Shower and general coverage



BATHROOM AND POWDER ROOM LAYOUT EXAMPLES WITH 3'x8' & 3'x10' FLOOR WARMING SYSTEMS

Figure 7: 3' x 8' EasyMat™ in Double Vanity area
15' (457 cm)

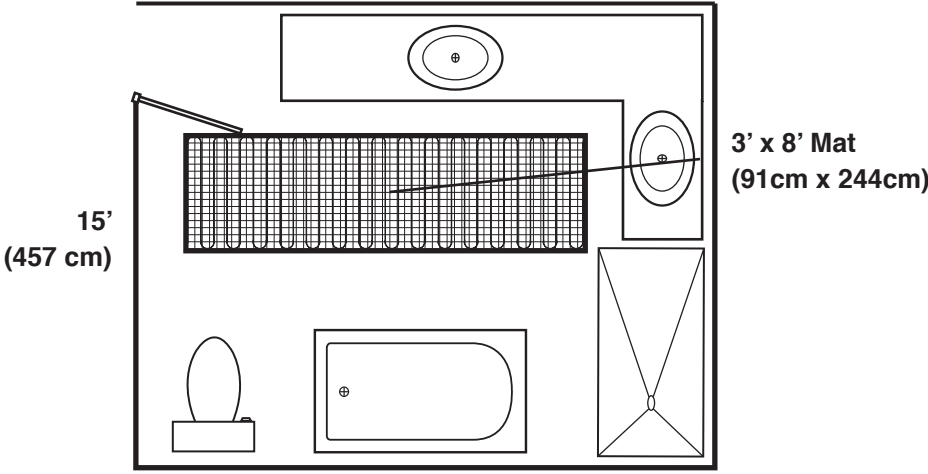
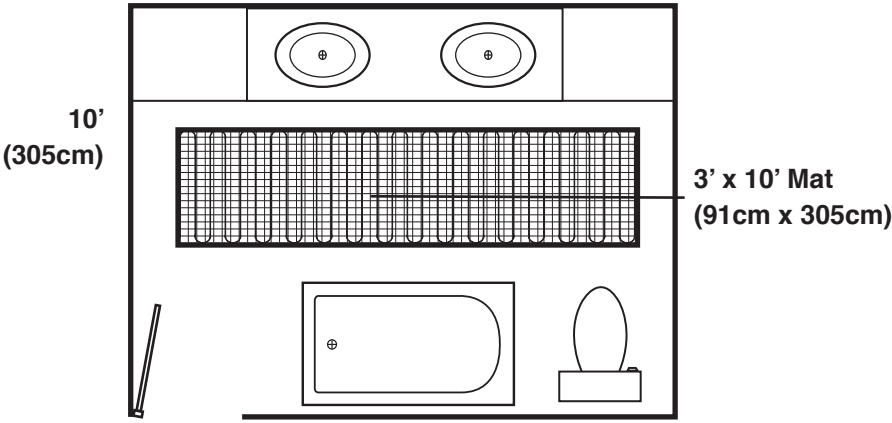

Figure 8: 3' x 10' EasyMat™ by Shower and general coverage
13' (396cm)



RECORD YOUR SYSTEM'S OHM READINGS HERE FOR READY REFERENCE

Four (4) Ohm readings should be taken from each mat at each stage of the floor warming system installation as listed below. This is necessary to ensure that your system is functioning properly and that no breaks or shorts have occurred that could affect its performance or integrity.

1. **Core to Core:** This is the reading between the two inner conductors of the lead wires.
2. **Sheath to Sheath:** This is the reading between the two outer ground sheaths of the lead wires.
3. **Core to Sheath START lead:** This is the reading between the inner core and outer ground sheath of the lead wire at the beginning of the mat. This reading should be infinity.
4. **Core to Sheath END Lead:** This is the reading between the inner core and outer ground sheath of the lead wire at the finish point of the mat. This reading should be infinity.

A digital Ohm meter should be used when taking readings. The meter should be set to measure resistance in the range of 0 - 200 Ohms and fresh batteries should be installed before commencing.

Product # or Size	Core to Core	Sheath to Sheath	Core to Sheath START Lead	Core to Sheath END Lead
Ohm Reading	Ohms	Ohms	Infinity	Infinity
After Unpacking			Check	Check
After Laying Mat On Floor			Check	Check
After Laying Tile			Check	Check
When finished with the installation, record the final core to core Ohm readings on the warranty registration card and return it to WarmlyYours.				

 **NOTE:** Remove the UL label(s) with the factory Ohms reading from the warming mat(s) and store in a convenient location for future reference, preferably at the electrical panel box with the floor warming installation plan and documents.

PROPER INSULATION PROMOTES HEAT RETENTION

When WarmlyYours floor warming systems are installed on a concrete slab, we strongly recommend adding a layer of insulation to the slab prior to installing the radiant floor heating system.

Some of the heat that would otherwise be transferred to the flooring surface will remain in the slab, causing the floor's surface temperature to be considerably lower. This is true with any floor warming system.

When installed on top of a concrete slab without insulation, it is generally accepted that a radiant floor warming system will take the chill away from the floor and provide a small amount of warmth.

Adding insulation on top of the slab and beneath any floor warming system will allow a greater percentage of the heat generated to transfer to the flooring surface. This leads to greater efficiency and therefore faster warm up times, higher expected surface temperatures and lower energy usage. The floor will have the capacity to warm to a comfortable temperature, and in some cases can be employed as the primary heat source for that room. Wiring Diagram for WarmlyYours nSpiration Series Thermostats

Wiring Diagram for WarmlyYours nSpiration Series Thermostats

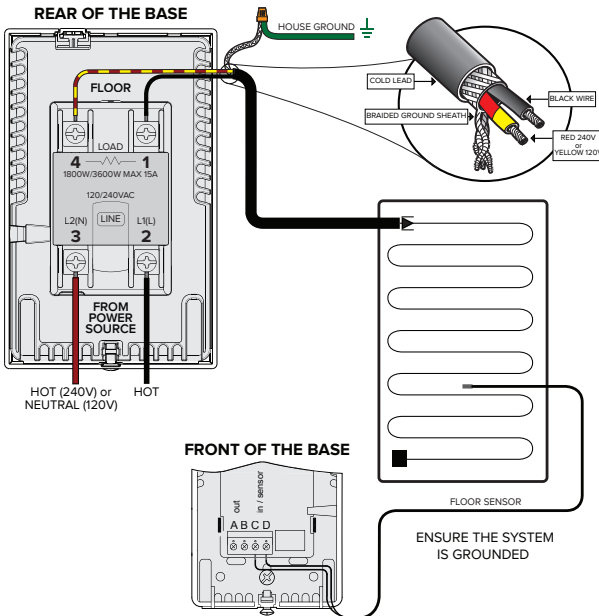

WARMLYYOURS FLOOR WARMING SYSTEM WARRANTY REGISTRATION

Thank you for purchasing your new WarmlyYours floor warming system. To register your system, please send a copy to WarmlyYours via mail at 590 Telser Rd, Suite B Lake Zurich, IL 60047, FAX to (800) 408-1100, or scan and send via email to: WarrantyRegistration@warmlyyours.com within 30 days of date of purchase.

1. HOMEOWNER INFORMATION	
Name	
Phone	
Address	
Email	
City	
State	Zip

2. INSTALLER INFORMATION	
Check here if homeowner installed <input type="checkbox"/>	
Company Name	
Address	
Email	
City	
State	Zip
Installer Name	
Company Fax	

3. HEATING SYSTEM INFORMATION						
Install Date						
Installed Under: <input type="checkbox"/> Tile <input type="checkbox"/> Stone <input type="checkbox"/> Laminate Wood <input type="checkbox"/> Other _____						
Sub Floor Material						
Set In					Total Mats Installed _____	
	Mat 1	Mat 2	Mat 3	Mat 4	Mat 5	Mat 6
Mat Size						
Final Ohm Reading						

WARMLYOURS FLOOR WARMING SYSTEM WARRANTY

WarmlyYours, Inc., warrants the WarmlyYours floor warming system mats ("the Product") to be free from defects in materials and workmanship for ten years from the date of purchase, provided that the Product is installed in accordance with the WarmlyYours product installation guide, any special written or oral design or installation guidelines provided by WarmlyYours for the specific project that the Product is intended, the provisions of the National Electric Code (NEC), and all applicable local building and electrical codes. If the Product is determined to be defective in materials and workmanship, and has not been damaged as a result of misuse, misapplication or improper installation, WarmlyYours, Inc. will reimburse the cost for location of the fault, repair of Product, and any labor and materials required to perform the repair. If repair of the Product is not feasible, WarmlyYours will replace the Product or refund the original cost of the Product. Controls sold under the WarmlyYours name are warranted for specific coverage periods. Please see www.WarmlyYours.com for the length of warranty coverage for each control. Should the control be defective or malfunction, return the control to WarmlyYours and it will be repaired or replaced (at WarmlyYours' option). The warranty does not cover removal or reinstallation costs. Other controls carry their manufacturer's warranty. See entire warranty in packaging.

WarmlyYours Inc. assumes no responsibility under this warranty for any damage to the Product prior to or during installation by anyone, including, but not limited to trades people or visitors to the job site, or damage caused as a result of post installation work. Call our toll free number, (800) 875-5285, if you have any questions about installation. The Limited Warranty is null and void if the Product owner or his representative attempts to repair the Product without receiving authorization. Upon notification of an actual or possible problem, WarmlyYours will issue an Authorization to Proceed under the terms of the Limited Warranty.

Warranty Subject to the Following Conditions:

1. The warranty of the warming system must be registered by completing and returning the attached 'System Warranty Registration' card to WarmlyYours, Inc. within thirty days of date of purchase. Please keep your invoice, as proof of date of purchase will be required in the event of a claim.
2. The warming mat must be installed flat under tile or stone flooring in a latex modified thinset or a portland-based cement.
3. The warming system must be electrically grounded and protected by a GFI (Ground Fault Interrupter).
4. The installation must comply with all national and local electrical and building codes, as well as any other applicable statutory requirements.
5. The manufacturer hereby reserves the right to inspect the installation site at any reasonable time.
6. The warranty is not automatically transferred with change of ownership, but the manufacturer may, on application, transfer the warranty for the period remaining. This transfer is solely at the discretion of the manufacturer.
7. The warming system should be used strictly in accordance with the following:
 - 7.1 Hard wire the warming system mats to a dedicated circuit. The voltage of the circuit should match the voltage of the warming system, and the size of the circuit should be such that the warming system does not occupy more than 80% of the circuit capacity.
 - 7.2 Should you feel no warmth on the floor within 60 minutes, verify that there is power to the control or thermostat. Contact WarmlyYours, Inc. after verifying that there is power at the plug point. Under no circumstances should you or anyone else tamper with or attempt to repair the warming system - this will render the warranty null and void.
 - 7.3 Switch the warming system on and off as you would any conventional electric heater, although timers or thermostats may be used if preferred.
 - 7.4 Use reasonable care in the operation of the warming system. Do not drop heavy articles on the flooring or pierce the flooring with sharp objects.
 - 7.5 All restrictions and warnings detailed in the installation guide must be strictly followed.

WARMLYOURS, INC. DISCLAIMS ANY WARRANTY NOT PROVIDED HEREIN, INCLUDING ANY IMPLIED WARRANTY OF MERCHANTABILITY OR IMPLIED WARRANTY OF FITNESS FOR A PARTICULAR PURPOSE. WARMLYOURS, INC. FURTHER DISCLAIMS ANY RESPONSIBILITY FOR SPECIAL, INDIRECT, SECONDARY, INCIDENTAL, OR CONSEQUENTIAL DAMAGES ARISING FROM OWNERSHIP OR USE OF THIS PRODUCT, INCLUDING INCONVENIENCE OR LOSS OF USE. THERE ARE NO WARRANTIES WHICH EXTEND BEYOND THE FACE OF THIS DOCUMENT. NO AGENT OR REPRESENTATIVE OF WARMLYOURS HAS ANY AUTHORITY TO EXTEND OR MODIFY THIS WARRANTY UNLESS SUCH EXTENSION OR MODIFICATION IS MADE IN WRITING BY A CORPORATE OFFICER.