

Runva 11 XP

Full Steel 3 Stages Planetary Reducer

Runva™ **WINCH EXPERT**
In Pursuit of Top Reliability

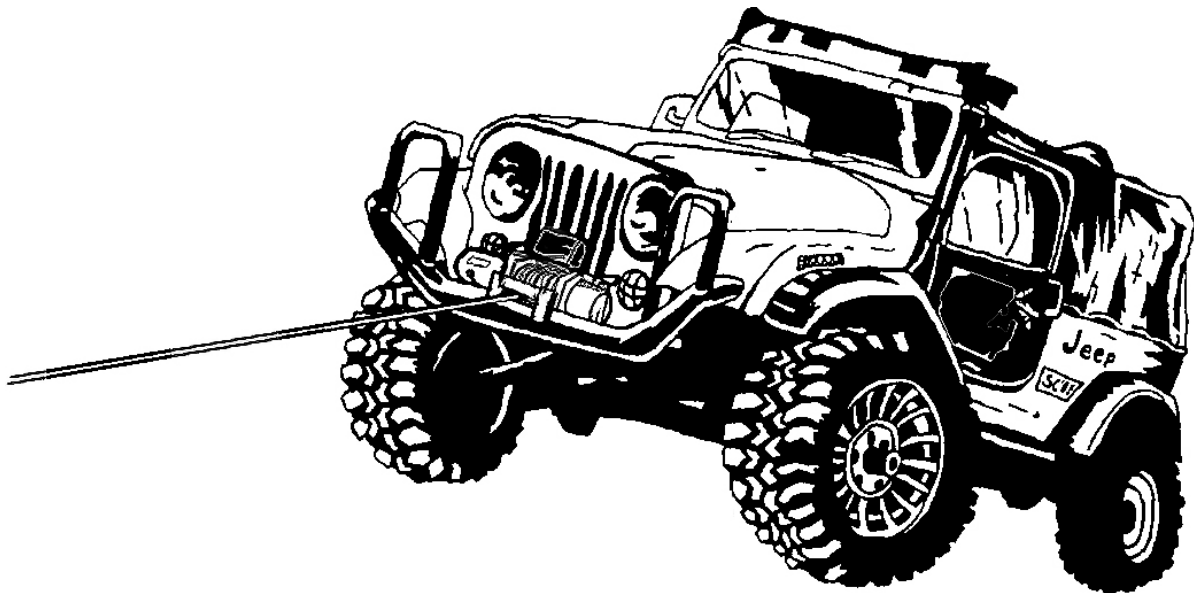

Warning!

Read the Book Before
Installation & Operation

CONTENTS

WARNING! SAFETY PRECAUTIONS	1
TROUBLESHOOTING	6
WINCH ASSEMBLY DRAWING	7
WINCH PARTS NUMBERS	8
SPECIFICATION.....	9

Wiring Instruction (Factory Installed)

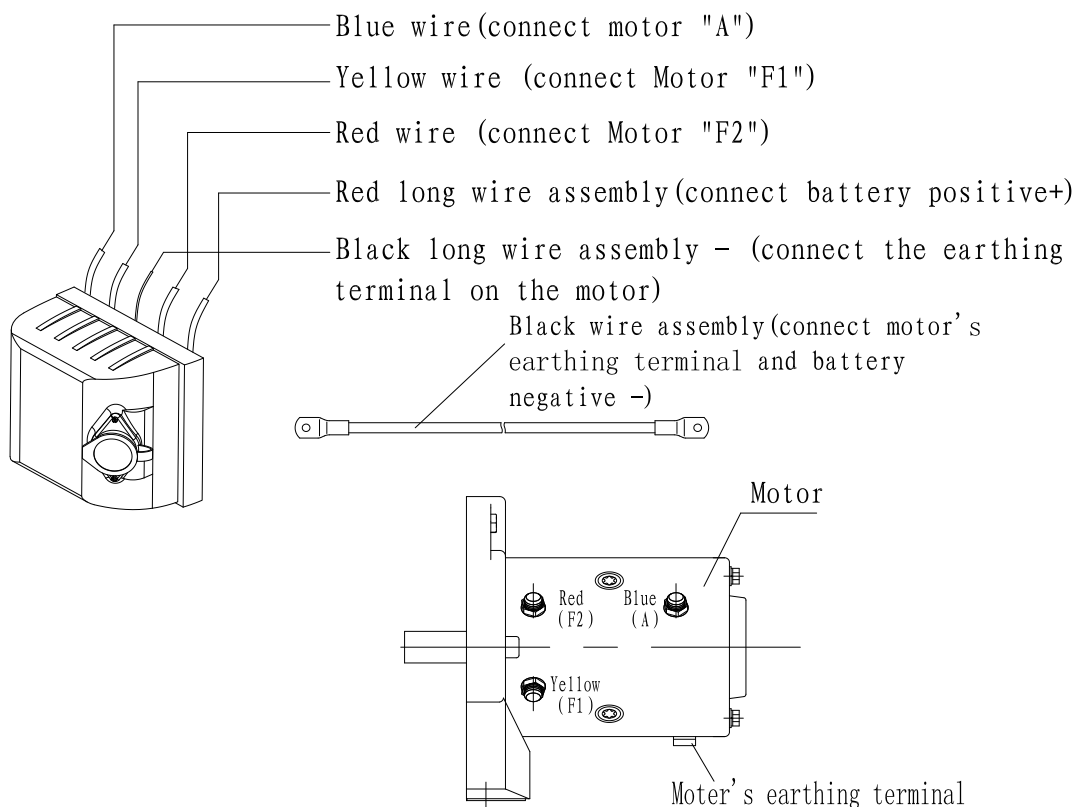

Warning (Keep This Paper)



About Using/Replacing The Steel Cable For The Winch

- 1. Spray Lube / Grease on Winch Cable Regularly**
- 2. Start each pull with a minimum of 5 wraps around the drum**
- 3. Use the bottom 2 layer for max efficiency**
- 4. Cut The Cable To The Length You Will Need (Otherwise Not Efficiency)**
 - **4x4 Jeep Off-Road ----- 50 to 90 feet**
 - **Tow Truck ----- 35 to 55 feet**
 - **Car Trailer ----- 25 to 55 feet**
 - **Other Operation ----- Length Need + 5 feet(On Drum)**
- 5. To Change / Replace Steel Cable / Rope:**
 - **Clutch To “Out” (Freespool)**
 - **Hand Pull Out Cable / Rope All The Way To The End**
 - **Take Off The Bolt Lock On The Drum**
 - **Take Off The Cable End**
 - **Put In and Lock The New Cable / Rope End On The Drum**
 - **Clutch To “In” (Engage)**
 - **Power In By The Switch**
 - **Roll Back The Cable / Rope In Good Order**



GENERAL SAFETY PRECAUTIONS



As you read these instructions, you will see WARNINGS, CAUTIONS, NOTES and NOTES. Each message has a specific purpose. WARNINGS are safety messages that indicate a potentially hazardous situation, which, if not avoided could result in serious injury or death. CAUTIONS are safety messages that indicate a potentially hazardous situation which, if not avoided, may result in minor or moderate injury. A CAUTION may also be used to alert against unsafe practice. CAUTIONS and WARNINGS identify the hazard, indicate how to avoid hazard, and advise of the probable consequence of not avoiding the hazard. NOTES are messages to avoid property damage. NOTES are additional information to help you complete a procedure. PLEASE WORK SAFELY!

 WARNING	
	
<p>CHEMICAL AND FIRE HAZARD Failure to observe these instructions could lead to severe injury or death.</p> <ul style="list-style-type: none"> • Always remove jewelry and wear eye protection. • Never lean over battery while making connections. • Always verify area when drilling is clear of fuel lines, fuel tank, brake lines, electrical wires, etc • Never route electrical cables: <ul style="list-style-type: none"> - Across any sharp edges. - Through or near moving parts. - Near parts that become hot. • Always insulate and protect all exposed wiring and electrical terminals. • Always install terminal boots as directed in installation instructions. 	

 WARNING		
		
<p>MOVING PARTS ENTANGLEMENT HAZARD Failure to observe these instructions could lead to severe injury or death.</p> <p>To avoid injury to hands or fingers.</p> <ul style="list-style-type: none"> • Always keep hands clear of wire rope, hook loop, hook and fairlead opening during installation, operation, and when spooling in or out. • Always use extreme caution when handling hook and wire rope during spooling operations. • Always use supplied hook strap whenever spooling wire rope in or out, during installation or operation to avoid injury to hands or fingers. 		

 WARNING	
	
<p>FALLING OR CRUSHING HAZARD Failure to observe these instructions could lead to severe injury or death.</p> <ul style="list-style-type: none"> • Never operate winch with less than 5 wraps of rope around the drum. Rope could come loose from the drum, as the rope attachment to the drum is not designed to hold a load. • Never use as an overhead hoist, or to suspend a load. • Never use to lift or move persons. 	



CAUTION

MOVING PARTS ENTANGLEMENT HAZARD

Failure to observe these instructions could lead to minor or moderate injury.

General Safety:

- Always Know Your Winch: Take time to fully read and understand the included Installation and Operations guide, and Basic Guide to Winching Techniques, in order to understand your winch and the winching operation.
- Never operate this winch if you are under 16 years of age.
- Never operate this winch when under the influence of drugs, alcohol or medication.
- Never exceed winch or wire rope rated capacity. Double line using a snatch block to reduce winch load.

Installation Safety:

- Always choose a mounting location that is sufficiently strong to withstand the maximum pulling capacity of your winch.
- Always use factory approved switches, remote controls, accessories and installation components.
- Always use grade 5 or better hardware, never weld bolts and never use longer bolts than those supplied from factory.
- Always complete winch mounting and attachment of hook to hook loop before wiring winch during installation.
- Always position fairlead with WARNING label on top.
- Always spool the wire rope onto the drum as indicated by the drum rotation label on the winch. Required for automatic brake to work (if winch is so equipped) and for correct installation orientation.
- Always prestretch wire rope and respool under load before use. Tightly wound wire rope reduces chances of "binding", which is wire rope working it's way down into a loosely wound wire rope layer, and catching or damaging itself.



CAUTION

MOVING PARTS ENTANGLEMENT HAZARD

Failure to observe these instructions could lead to minor or moderate injury.

Winching Safety:

- Always inspect winch installation, wire rope and hook condition before operating winch. Frayed, kinked or damaged wire rope must be replaced immediately. Loose or damaged winch installation must be corrected immediately. Immediately replace a hook that is damaged, bent or twisted.
- Never leave remote control plugged into winch while free spooling, rigging, or sitting idle.
- Never hook wire rope back onto itself. This damages the wire rope. Always use a choker chain, wire choker rope or tree trunk protector on the anchor.
- Always prior to winching, remove any element that may interfere with safe winch operation.
- Always take your time when rigging for a winch pull.
- Always be certain the anchor you select will withstand the load, and the strap or chain will not slip.
- Never engage or disengage clutch if winch is under load, wire rope is in tension or wire rope drum is moving.
- Always unspool as much wire rope as possible when rigging. Double line or pick distant anchor point.
- Always stand clear of wire rope and load during operation.
- Never touch wire rope or hook while in tension or under load.
- Never touch wire rope or hook while someone else is at the control switch or during winching operation.
- Never touch wire rope or hook while remote control is plugged into winch.
- Always stand clear of wire rope and load and keep others away while winching.



CAUTION

MOVING PARTS ENTANGLEMENT HAZARD

Failure to observe these instructions could lead to minor or moderate injury.

Winching Safety:

- Always require operator and bystanders to be aware of stability during winching of vehicle and/ or load.
- Always keep remote control lead clear of the drum, wire rope and rigging. Inspect for cracks, pinches, frayed wires or loose connections. Replace if damaged.
- Always pass remote control through a window to avoid pinching lead in door, when using remote inside a vehicle.



CAUTION

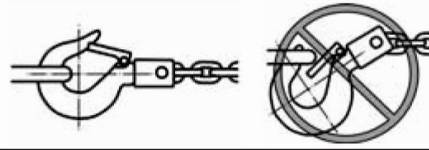

MOVING PARTS ENTANGLEMENT HAZARD

Failure to observe these instructions could lead to minor or moderate injury.

- Never apply load to hook tip or latch. Apply load only to the center of hook.
- Never use a hook whose throat opening has increased, or whose tip is bent or twisted.



CAUTION



CUT AND BURN HAZARD

Failure to observe these instructions could lead to minor or moderate injury.

To avoid injury to hands or fingers:

- Always wear heavy leather gloves when handling a wire rope.
- Never let wire rope slip through your hands.

To avoid injury to hands or fingers:

- Always be aware of possible hot surface at winch motor, drum or wire rope during or after winch use.

NOTICE

AVOID WINCH AND EQUIPMENT DAMAGE

- Always avoid continuous side pulls which can pile up wire rope at one end of the drum. This can damage your wire rope or winch.
- Always ensure the clutch is fully engaged or disengaged.
- Never use winch to tow other vehicles. Shock loads can momentarily exceed capacity of wire rope and winch.
- Always use care to not damage your frame when anchoring your vehicle during a winching operation.
- Never "jog" wire rope under load. Shock loads can momentarily exceed capacity of wire rope and winch.
- Never use winch to secure a load during transport.
- Never submerge winch in water.
- Always store the remote control in a protected, clean, dry area.

MAINTENANCE

⚠ WARNING

Never operate winch with less than 5 wraps of rope around the drum. Rope could come loose from the drum, as the rope attachment to the drum is not designed to hold a load.

- Inspect the wire rope before and after each winching operation. If the wire rope has become kinked or frayed, the wire rope needs to be replaced. Be sure to also inspect the winch hook and hook pin for signs of wear or damage. Replace if necessary.
- Keep winch, wire rope, and switch control free from contaminants. Use a clean rag or towel to remove any dirt and debris. If necessary, unwind winch completely (leaving a minimum of 5 wraps on spooling drum), wipe clean, and rewind properly before storage. Using a light oil on the wire rope and winch hook can keep rust and corrosion from forming.
- Operating your winch for a long period of time places an extra burden on your vehicle's battery. Be sure to check and maintain your battery and battery cables according to manufacturer guidelines. Also inspect switch control and all electrical connections to be certain they are clean and tight fitting.
- Inspect the remote control for damage, if so equipped. Be sure to cap the remote socket to prevent dirt and debris from entering the connections. Store remote control in a protected, clean, dry area.
- No lubrication is required for the life of the winch.

THE FINAL ANALYSIS

The basic guide to proper winching techniques cannot cover all the possible situations in which you may need to use a winch. In the final analysis, the decisions you make will determine the final outcome. So think through each situation and each step of use. Always be mindful of your own safety and the safety of others. Pay attention and you'll have fun.

TROUBLE SHOOTING

SYMPTOM	POSSIBLE CAUSE	SUGGESTED ACTION
Motor does not turn on	<ul style="list-style-type: none"> -Switch Assembly not connected properly -Loose battery cable connections -Defective switch assembly -Defective motor -Water has entered motor 	<ul style="list-style-type: none"> -Insert switch assembly all the way into the connector. -Tighten nuts on all cable connections. -Replace switch assembly. -Check for voltage at armature port with Switch pressed. If voltage is present, replace motor. -Allow to drain and dry. Run in short bursts without load until completely dry.
Motor runs but cable drum does not turn	<ul style="list-style-type: none"> -Clutch not engaged 	<ul style="list-style-type: none"> -Turn clutch to the "In" position. If problem persists, a qualified technician needs to check and repair.
Motor runs slowly or without normal power	<ul style="list-style-type: none"> -Insufficient current or voltage 	<ul style="list-style-type: none"> -Battery weak recharge. Run winch with vehicle motor running. -Loose or corroded battery cable connections. Clean, tighten, or replace.
Motor overheating	<ul style="list-style-type: none"> -Winch running time too long 	<ul style="list-style-type: none"> -Allow winch to cool down periodically.
Motor runs in one direction only	<ul style="list-style-type: none"> -Defective switch assembly. 	<ul style="list-style-type: none"> -Loose or corroded battery cable or motor cable connections. Clean and tighten. -Repair or replace switch assembly.
Winch braking malfunction.	<ul style="list-style-type: none"> -Winch working in wrong direction. -Brake slice worn or worn not. 	<ul style="list-style-type: none"> -Change winch working direction looking is to clockwise look at the motor end - Simply readjusted the braking angle or replaces the new brake slice.

! WARNING - Adjustment braking angle method: The spring according to the spring gyrotropic pre-tight two weeks, then shows the spline tooth set according to following braking cutaway view the adjustment angle for $20^{\circ} \pm 5^{\circ}$.

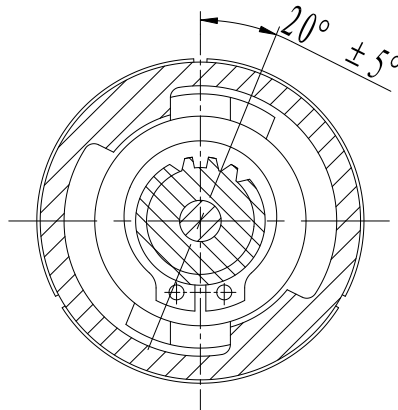

WINCH ASSEMBLY DRAWING

Runva 11XP

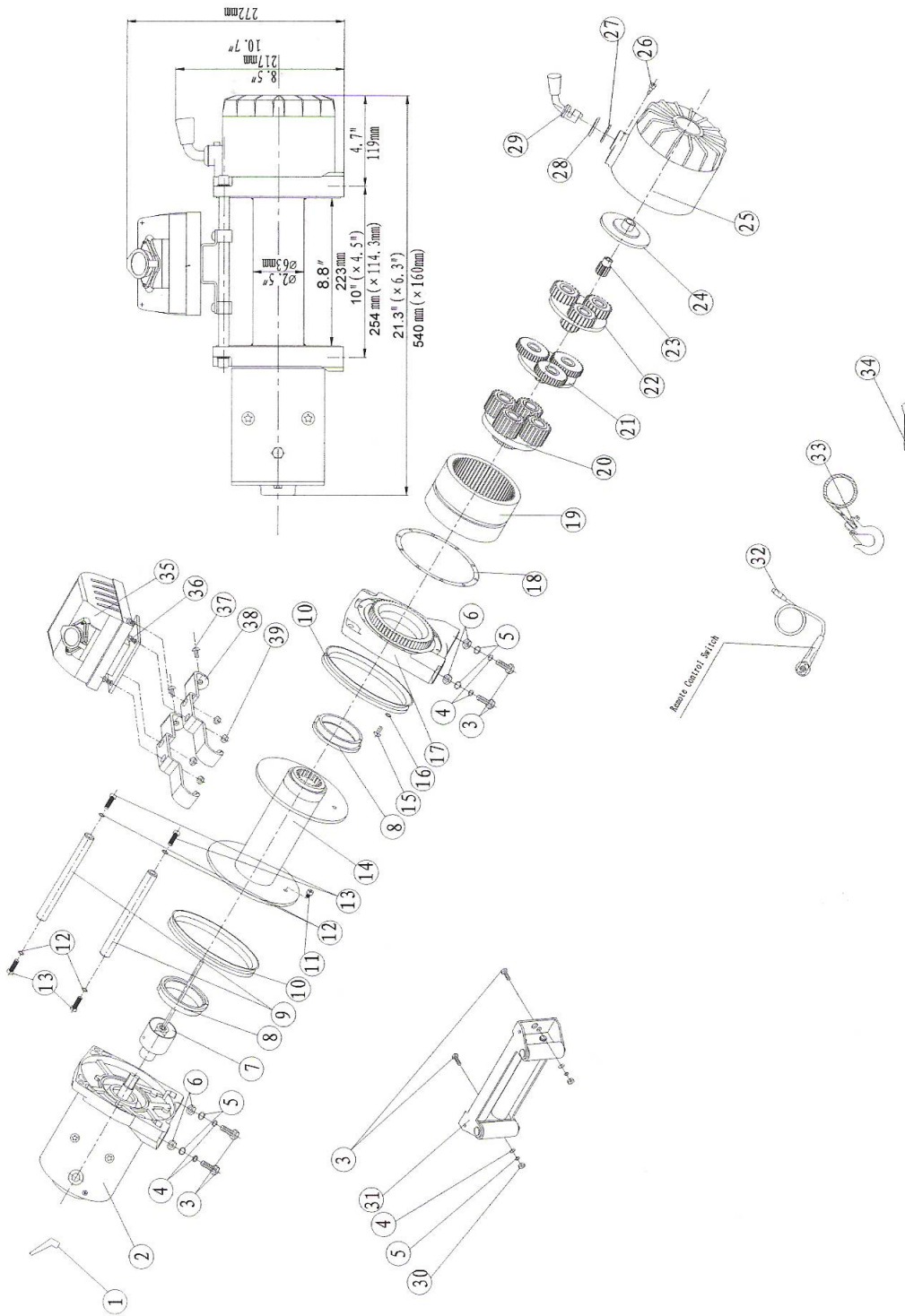

WINCH PARTS NUMBERS RUNVA 11XP

No.	Part #	Qty	Description	Remark
1	X1100001	3	Terminal Protect	
2	X1100100-S	1	Motor Assembly	
3	X1100002	6	Cap Screw M10 x 35	
4	X1100003	6	Lock Washer Φ10	
5	X1100004	6	Think Flat Washer Φ10	
6	X1100005	4	Hex Nut M10	
7	X1100200	1	Break / Shaft Assembly	
8	X1100006	2	Bushing—Drum	
9	X1100007	2	Tie Bar	
10	X1100008	2	Ring Seals	
11	X1100009	1	Cap Screw M6 x 10	
12	X1100010	4	Lock Washer Φ8	
13	X1100011	4	Cap Screw M8 x 30	
14	X1100300	1	Drum Assembly	
15	X1100012	10	Screw M4 x 25	
16	X1100013	10	Lock Washer Φ4	
17	X1100014	1	End Bearing	
18	X1100015	1	Gasket	
19	X1100016	1	Gear—Ring	
20	X1100400	1	Gear Carrier Assembly (Output)	
21	X1100500	1	Gear Carrier Assembly (Intermediate)	
22	X1100600	1	Gear Carrier Assembly (Input)	
23	X1100017	1	Gear—Input Sun	
24	X1100018	1	Trust Washer	
25	X1100019	1	Gear—Housing	
26	X1100020	1	Clutch Screw	
27	X1100021	1	Ring Seals	
28	X1100022	1	Clutch Cover	
29	X1100023	1	Clutch Handle	
30	X1100024	2	Locknut M10	
31	X1100700	1	Roller Fairlead	
33	X1100800-S	1	Control Box	
34	X1100900	1	Remote Control Switch (RC3)	
35	X1101000	1	Cable Assembly	
36	X1100029	1	Strap	
37	X1100027	2	Flat Head Screw M5 x 6	
38	X1100026	1	Control Box Fixing Panel	
39	X1100030	4	Hex Head Screw M8 x15	
40	X1100031	1	Control Box Soleplate	
41	X1100032	2	Plug Screw M5 x 8	
42	X1100033	2	Soleplate Bracket	
43	X1100034	4	Locknut M8	

SPECIFICATION

Rated line pull	110000 lbs (4990 kgs)
Motor: series wound	12V:Input: 4.9kW /6.5hp
Gear reduction ratio	230:1
Cable (Dia. × L)	Ø3/8" × 85 ' (Ø9.2mm × 26m)
Drum size (Dia. × L)	Ø2.48 " × 8.8 " (Ø63mm × 223 mm)
Mounting bolt pattern	10 " × 4.5 " (254mm × 114.3 mm) 4-M10
Overall dimensions (L × W × H)	21.3" × 6.3" × 10.7" 540mm × 160mm × 272mm

Pull, Speed, Amperes, Volts (First layer):

Line Pull lbs (kgs)	Line Speed ft/min (m/min)		Current A	
	12V DC	24V DC	12V DC	24V DC
0(0)	22.3(6.8)	/	100	/
4000(1814)	13.1(4.0)	/	220	/
8000(3629)	9.8(3.0)	/	330	/
11000(4990)	5.8(1.8)	/	540	/

Line Pull And Rope Capacity In Layer

Layer	Rated line pull lbs (kgs)	Total rope on the drum ft (m)
1	11000(4990)	16.1 (4.9)
2	8766(3976)	36.4 (11.1)
3	7286(3305)	60.0(18.3)
4	6233(2827)	83.7(25.5)

