

# avanat Instructions Installation

Solar shade

Toile solaire

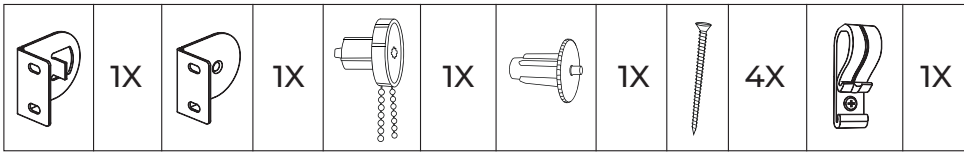

Les composantes réelles peuvent différer légèrement des illustrations / Actual components may vary slightly from the illustrations

**1a** À l'intérieur du cadre.  
Inside mount / Inside window frame.

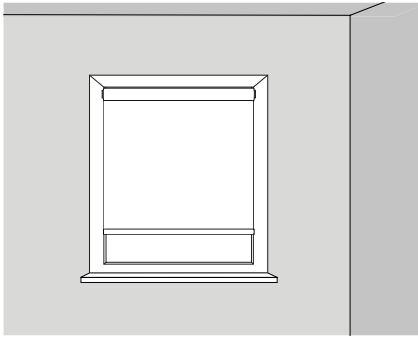

**1b** Au plafond.  
Ceiling mount.

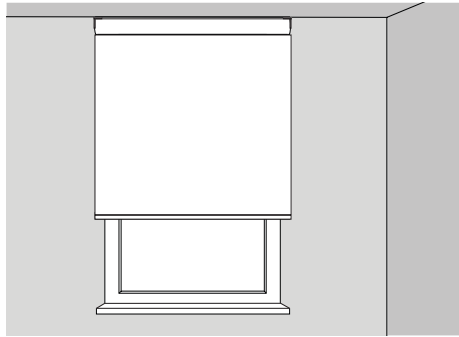

**1c** À l'extérieur du cadre.  
Outside mount / Outside window frame.

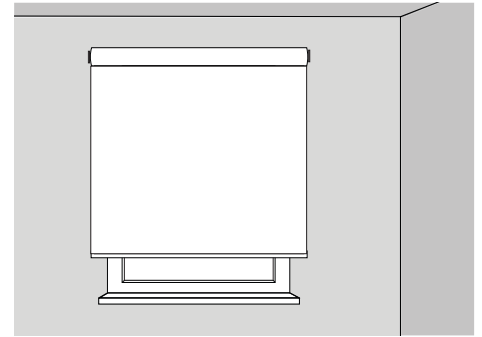

**2a** Visser sur le cadre.  
Screw on the window frame.

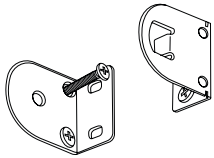

**2b** Visser au plafond.  
Screw on the ceiling.

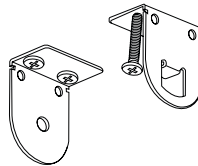

**2c** Visser au mur.  
Screw on the wall.

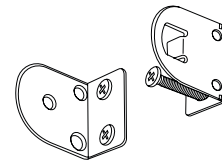

**3** Insérer les extrémités.  
Insert clutches.

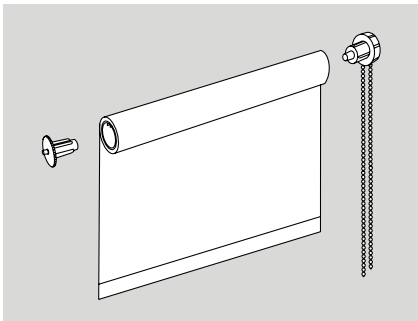

**4** Insérer chaque extrémité de la toile dans son support.  
Insert each end of the blind in its bracket.

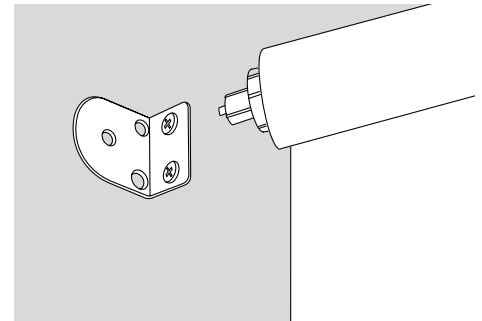
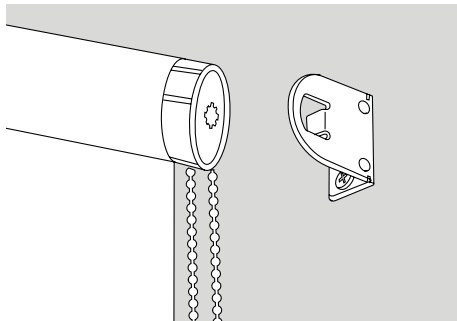

**5** Fixer le dispositif de tension pour la chaîne.  
Fix cord tensioning device to the wall or window frame.

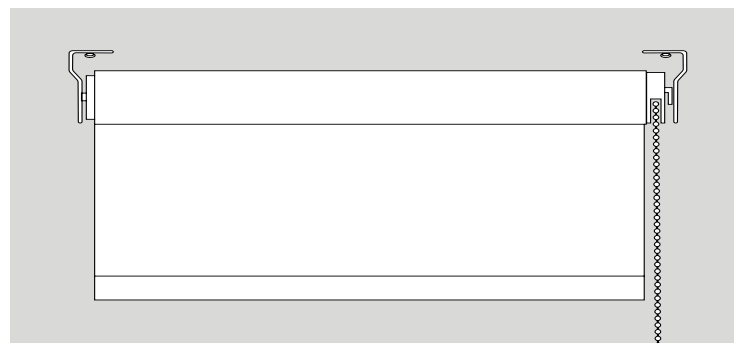
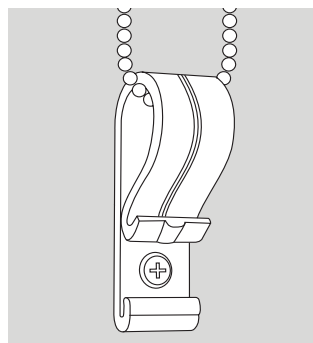
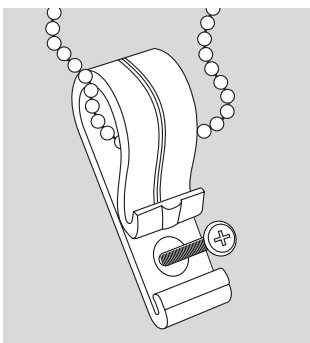

# avanat Instructions Coupe/Cut

Solar shade

- 1** Définir la dimension désirée.  
Define the desired width.

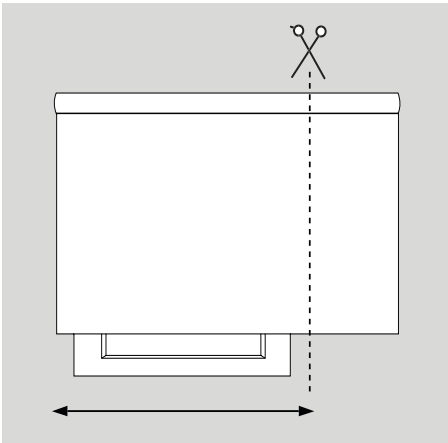

- 2** Dérouler la toile sur une surface plane et enlever la baguette. Marquer les dimensions.  
Unroll the canvas on a flat surface and remove the bottom bar. Mark the dimensions.

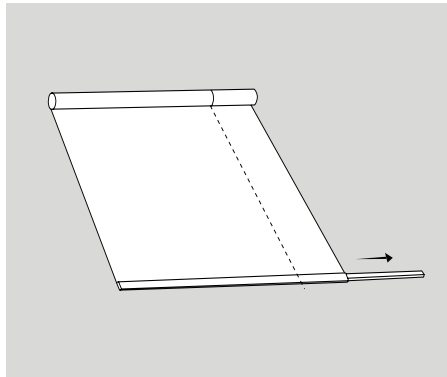

- 4** Couper au ciseau jusqu'au tube.  
Cut fabric using scissors until reaching the tube.

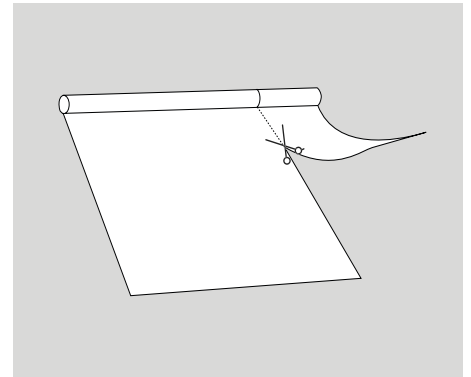

- 6** Sortir légèrement le tissu à l'extérieur du tube pour finaliser la coupe de la toile.  
Slightly pull the tube out to finalize the cut of the fabric.

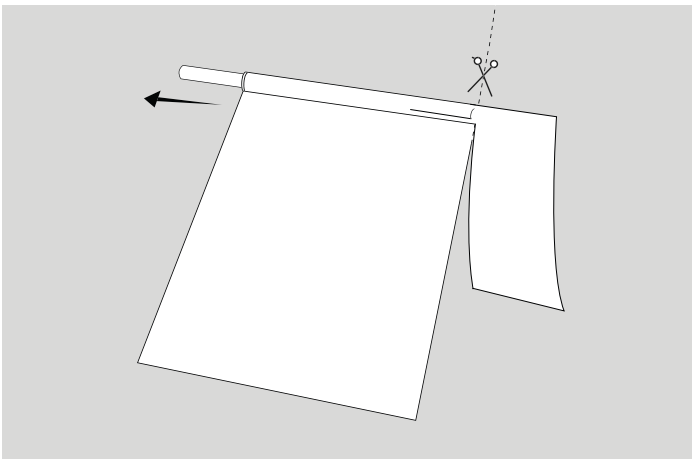

- 7** Repositionner ensuite le tissu de manière à libérer l'excédent de tube.  
Then reposition the fabric to release the excess tube.

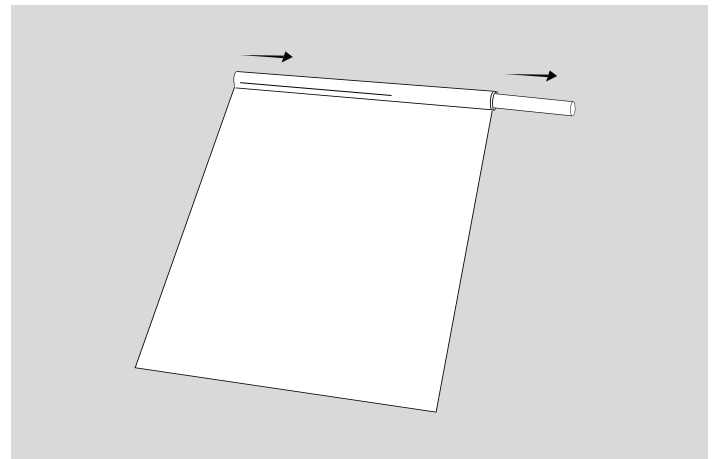

- 8** Scier la partie du tube d'aluminium qui dépasse, ainsi que la baguette.  
Using the saw, cut the excess part of the tube and the bottom bar.

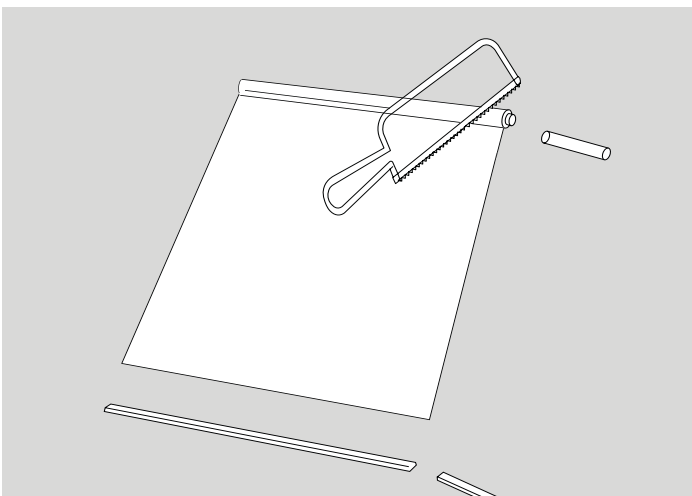

- 11** Remettre les extrémités et la baguette.  
Vous êtes prêt à l'installer!  
Insert bottom bar and clutches back. You are ready to install!

