

ASSEMBLY INSTRUCTION

U SOFA

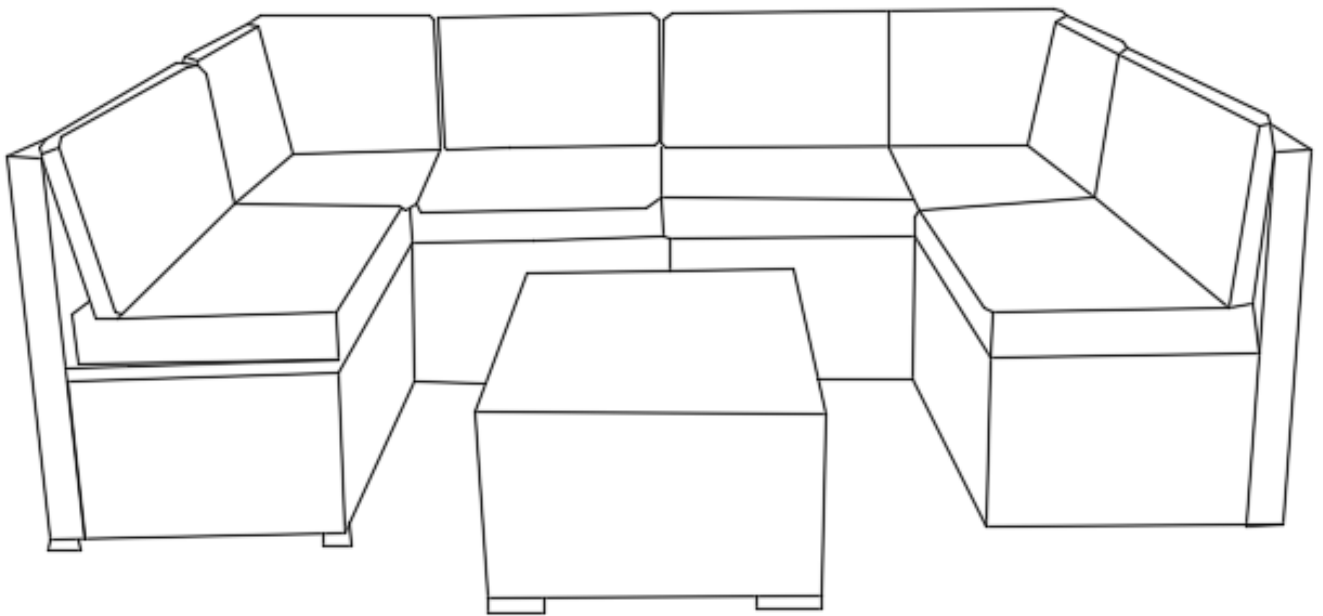

NOTE : 50 % TIGHTEN BEFORE FIXING ALL BOLTS

Part List & Hardware

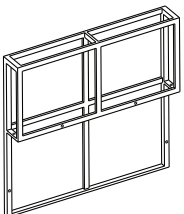
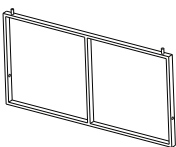
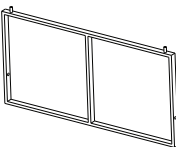
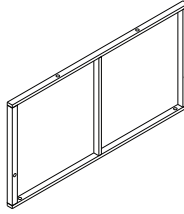
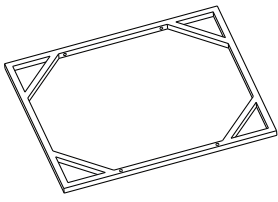
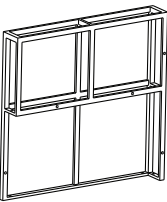
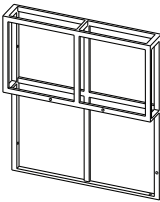
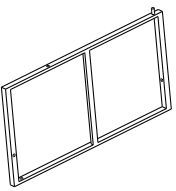
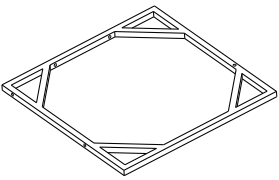
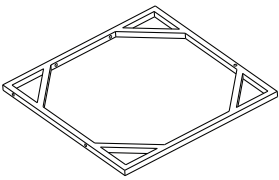
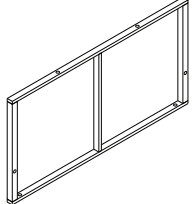
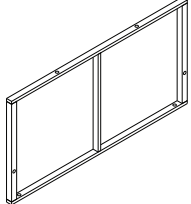
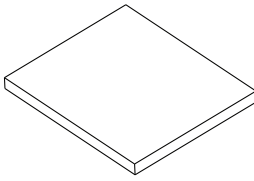
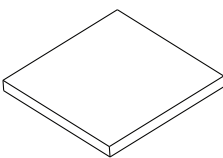
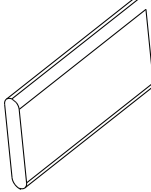
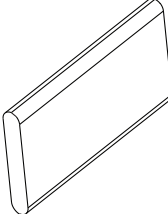
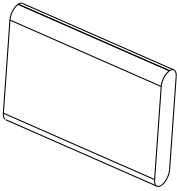
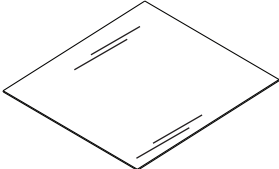
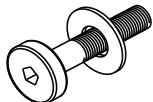
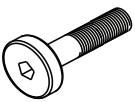
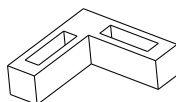
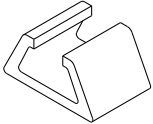
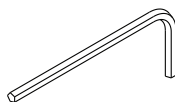
<p>A</p>  <p>Back Frame (4 pcs)</p>	<p>B</p>  <p>Panel Frame (4 pcs)</p>	<p>B1</p>  <p>Panel Frame (6 pcs)</p>	<p>C</p>  <p>Panel Frame (4 pcs)</p>
<p>D</p>  <p>Seat Frame (4 pcs)</p>	<p>E</p>  <p>Big Corner Frame (2 pcs)</p>	<p>F</p>  <p>Small Corner Frame (2 pcs)</p>	
<p>G</p>  <p>Panel Frame (2 pcs)</p>	<p>H</p>  <p>Seat Corner Frame (2 pcs)</p>	<p>I</p>  <p>Table Top Frame (1 pcs)</p>	
<p>Q</p>  <p>Panel Frame (2 pcs)</p>	<p>Z</p>  <p>Panel Frame (2 pcs)</p>	<p>J</p>  <p>Seat Cushion (4 pcs)</p>	
<p>K</p>  <p>Seat Corner Cushion(2 pcs)</p>	<p>L</p>  <p>Back Cushion (4 pcs)</p>	<p>M</p>  <p>Big Back Cushion (2 pcs)</p>	
<p>N</p>  <p>Small Back Cushion (2 pcs)</p>	<p>O</p>  <p>Table Glass (1 pc)</p>		
<p>1</p>  <p>Bolt M6x30mm (70 pcs)</p>	<p>2</p>  <p>Bolt M6x25mm (56 pcs)</p>	<p>3</p>  <p>Sofa Leg (28 pcs)</p>	
<p>4</p>  <p>Sofa Connector (10 pcs)</p>	<p>5</p>  <p>Allen key(2 pc)</p>		

STEP 1

Connect Back Frame (A) & Seat Frame (D) with Bolt (1)

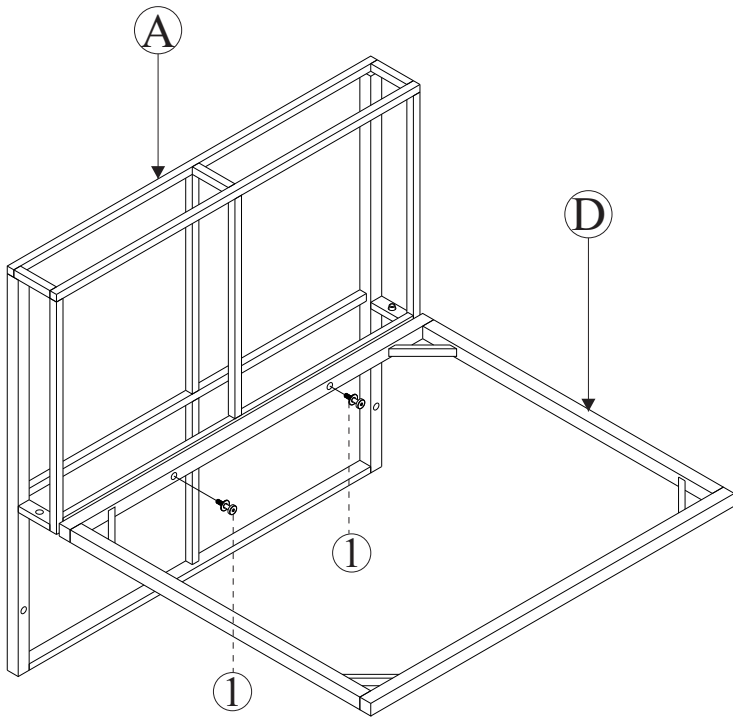

STEP 2

Connect part from STEP 1 & Panel Frame (B) with Bolt (1)

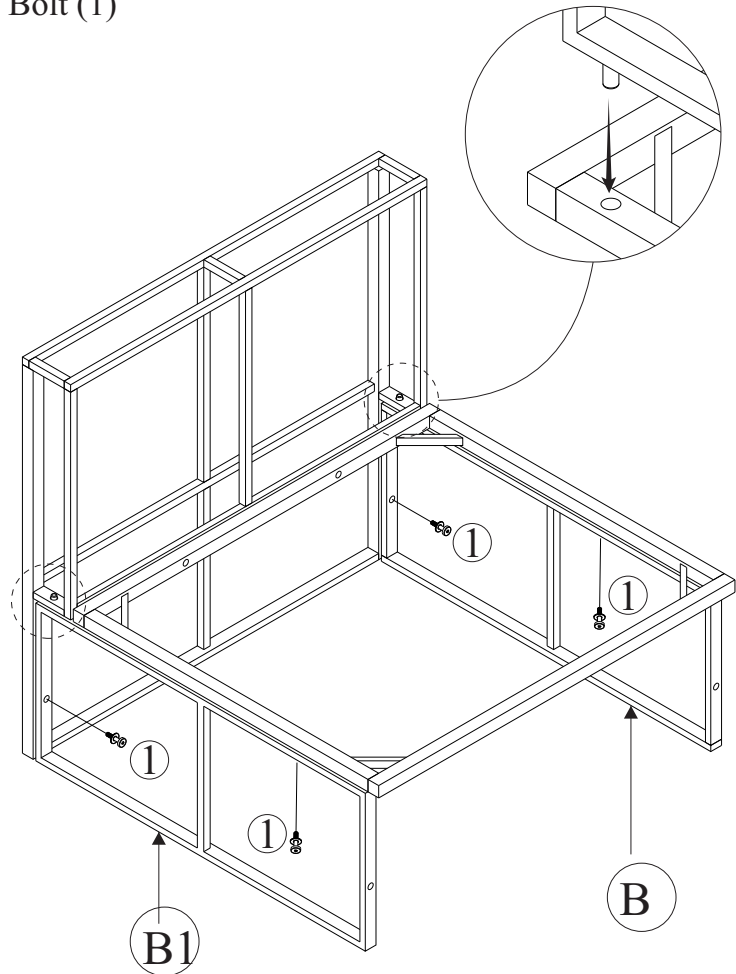

STEP 3

Connect part from STEP 2 & Panel Frame (C) with Bolt (2)

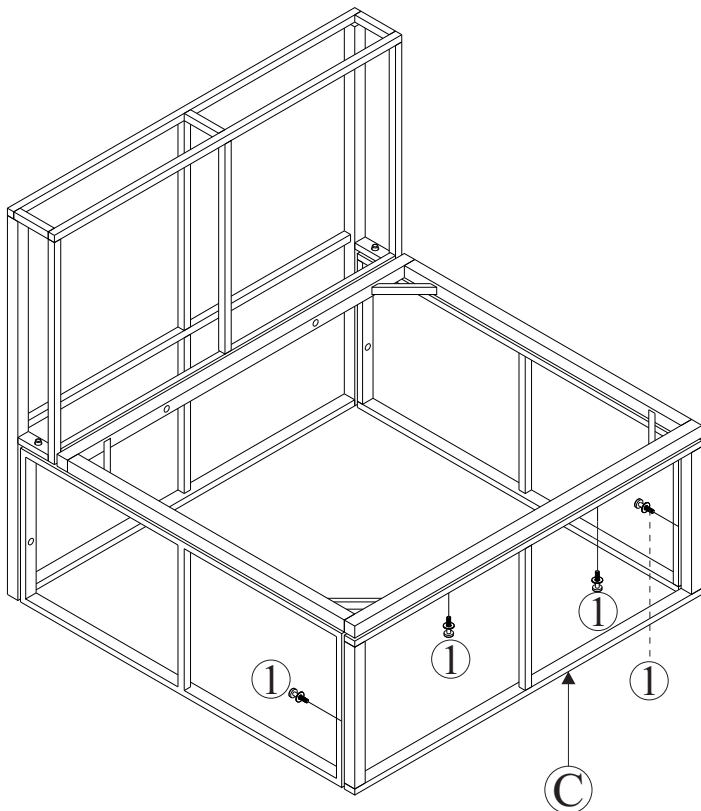

STEP 4

Connect part from STEP 3 & Sofa Leg (4) with Bolt (3)

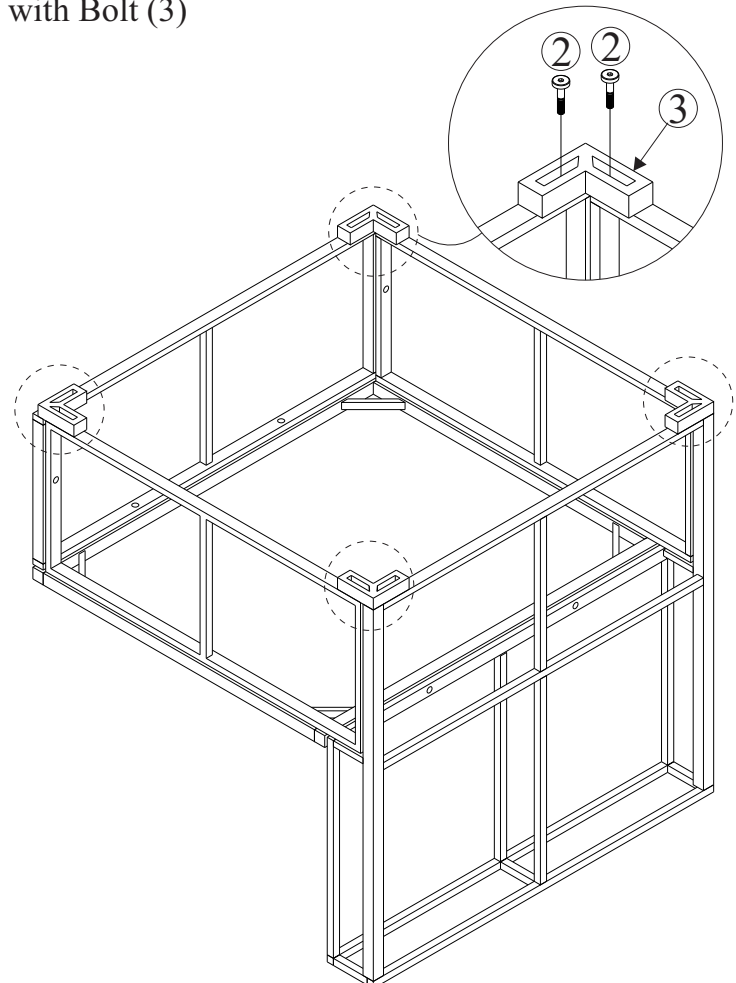

STEP 5

Put on Seat Cushion (J) & Back Cushion (L) to complete single chair

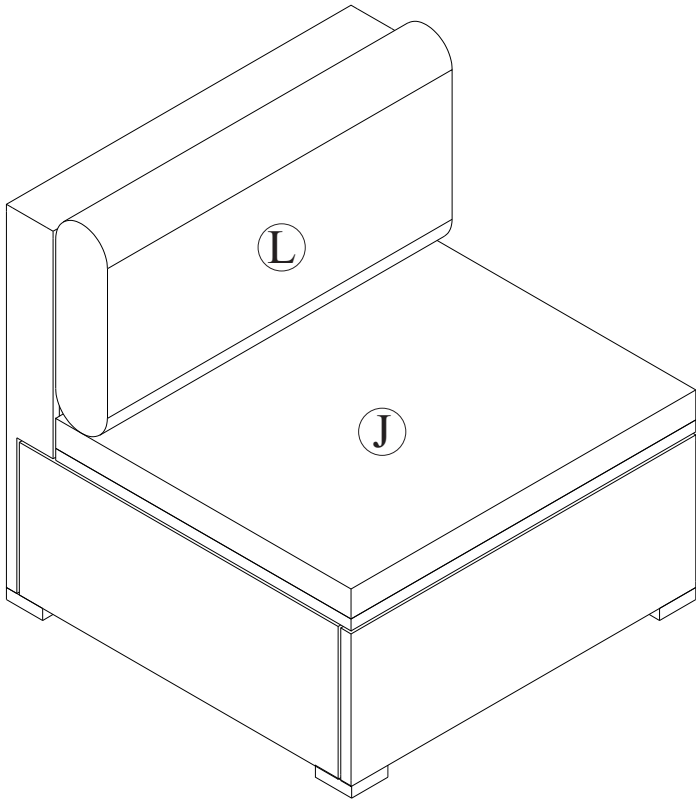

STEP 6

Connect Big Corner Frame (E) & Small Corner Frame (F) with Bolt (1)

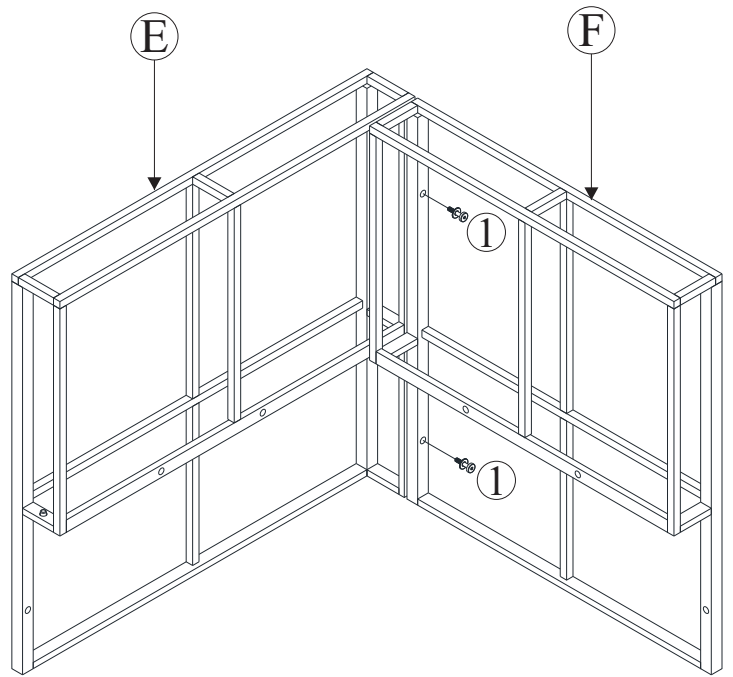

STEP 7

Connect part from STEP 6 & Seat Frame (H) with Bolt (1)

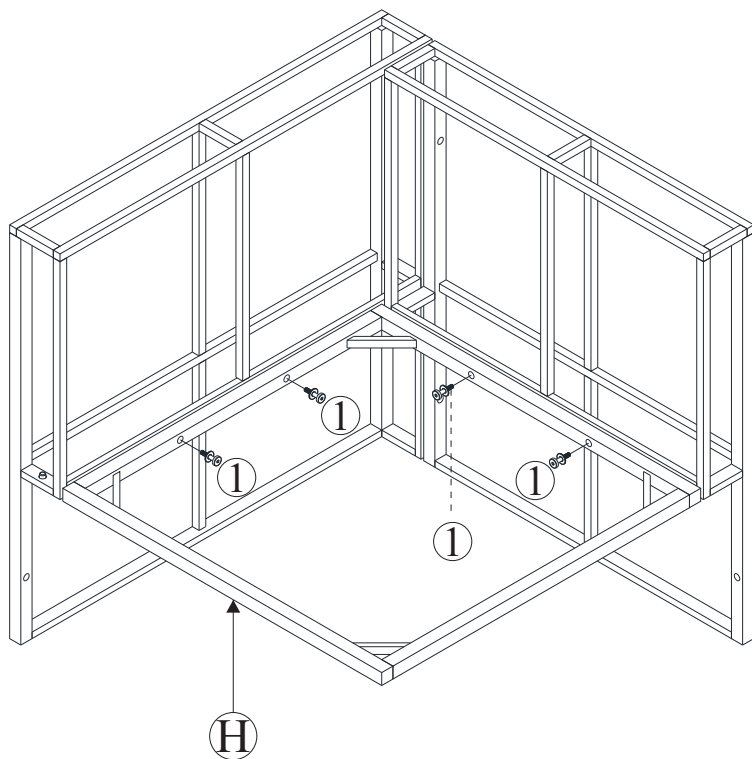

STEP 8

Connect part from STEP 7, Panel Frame (B) & Panel Frame (G) with Bolt (1)

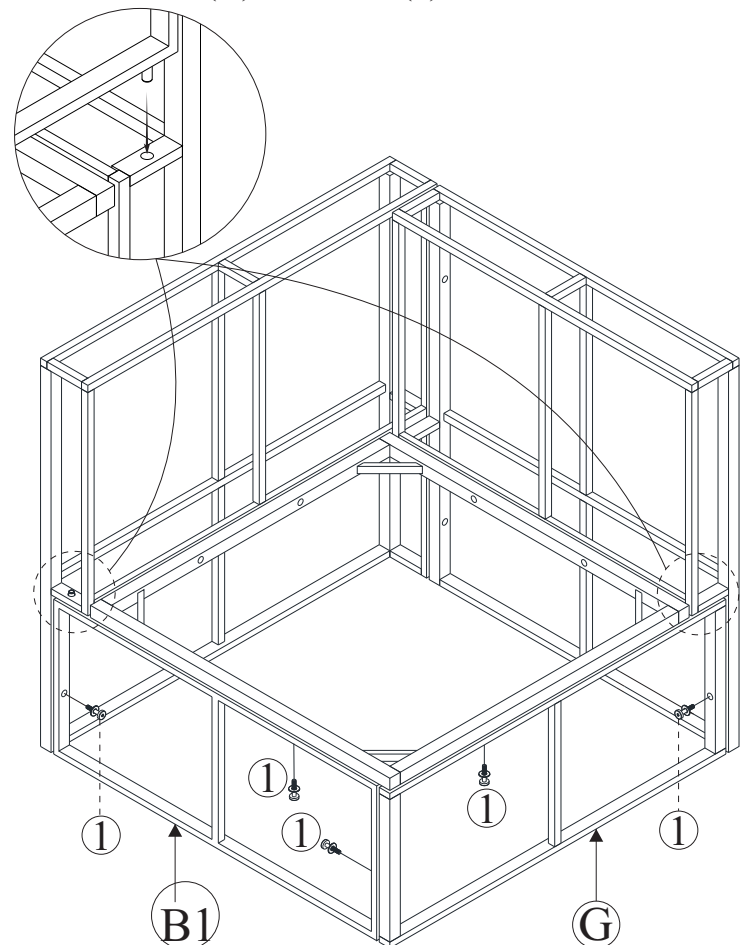

STEP 9

Connect part from STEP 8 & Sofa Leg (3) with Bolt (2)

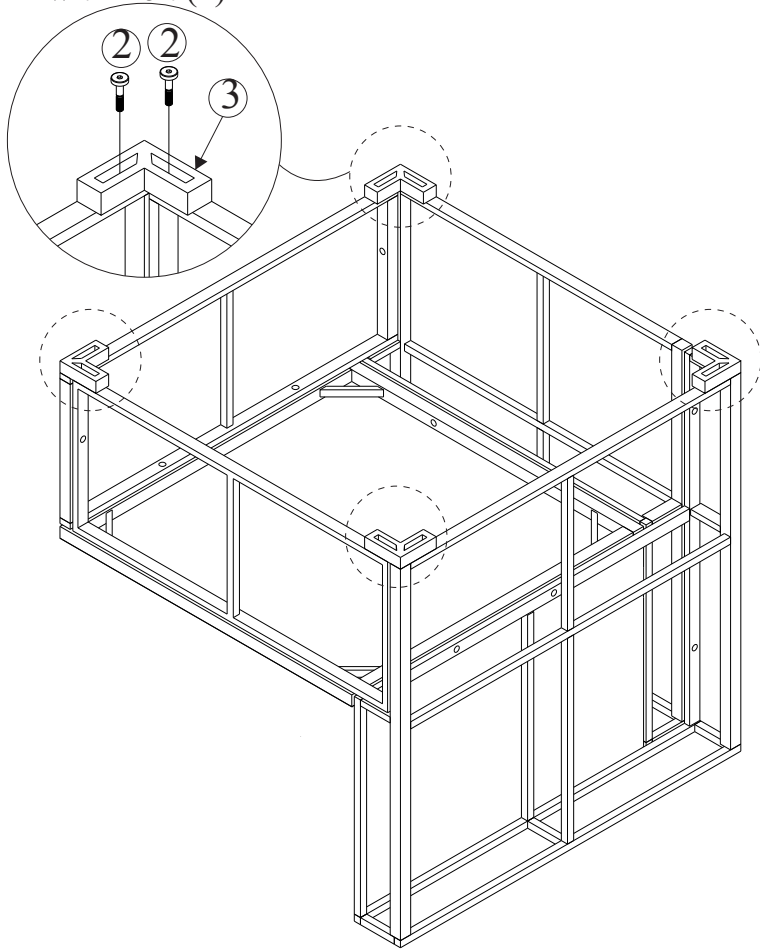

STEP 10

Put On Corner Seat Cushion (K), Big Back Cushion (M) & Small Back Cushion (N) to complete corner chair.

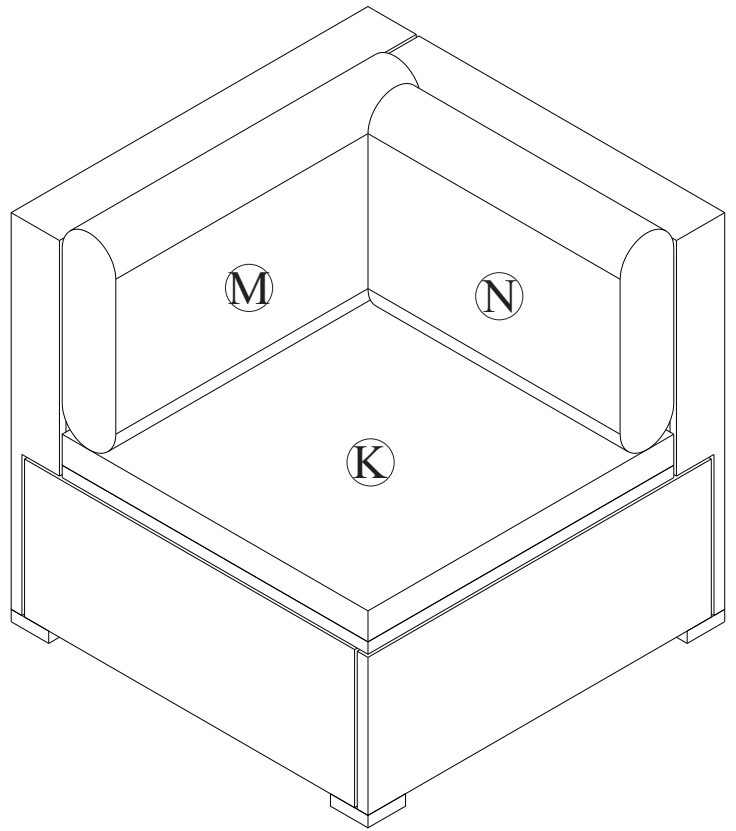

STEP 11

Connect Panel Frame (Q) & Table Top Frame (I) with Bolt (1)

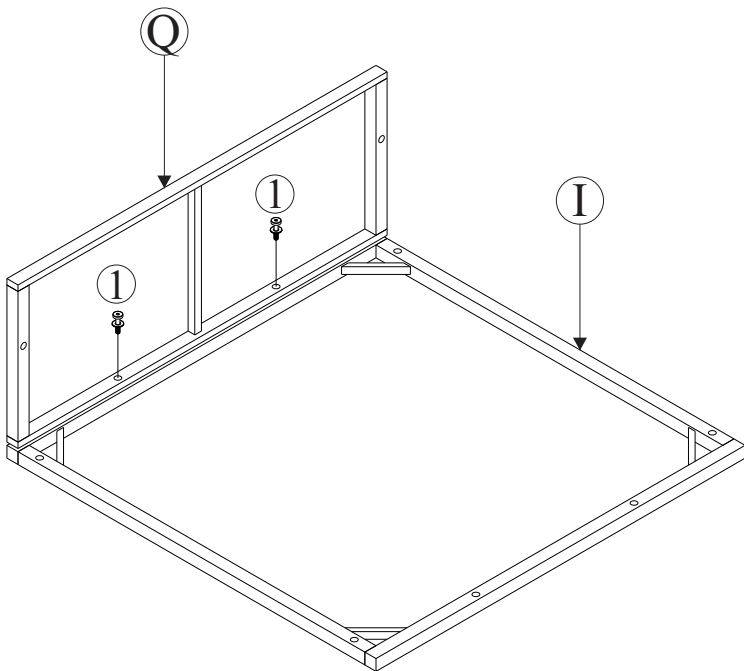

STEP 12

Connect part from STEP 11 & 2pcs Panel Frame (Z) with Bolt (1)

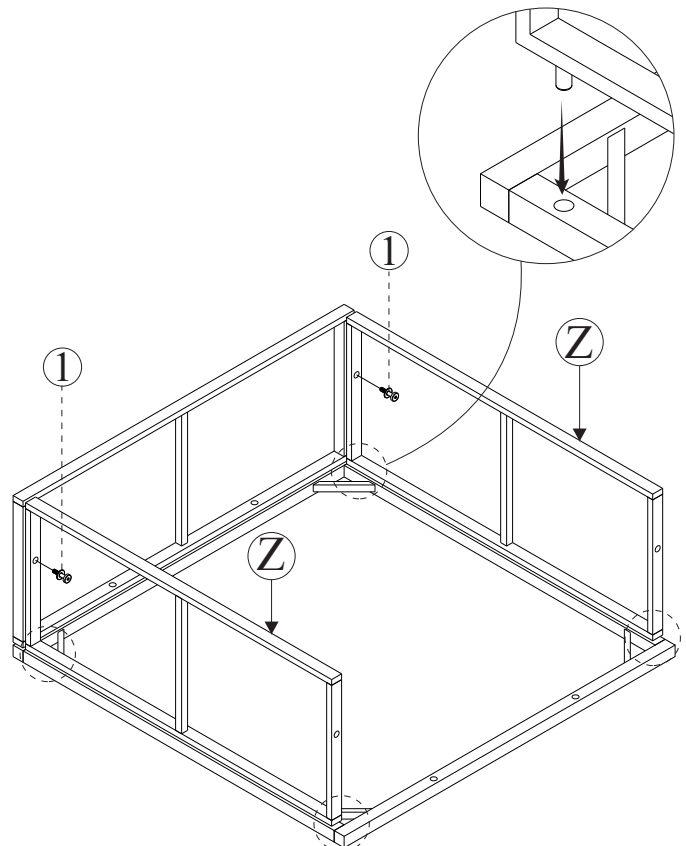

STEP 13

Connect part from STEP 12 & Panel Frame (Q) with Bolt (1)

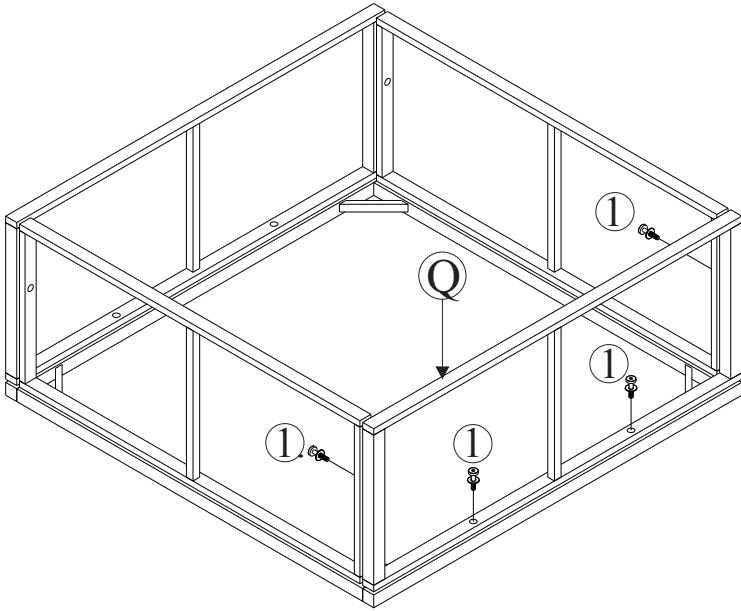

STEP 14

Connect part from STEP 13 & Sofa Leg (3) with Bolt (2)

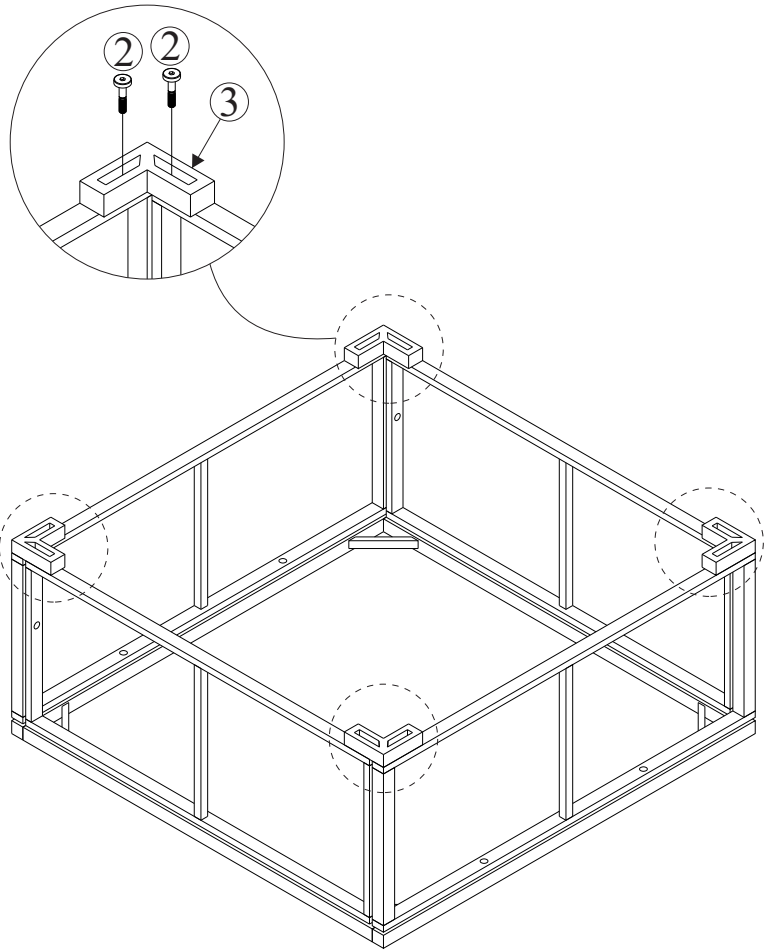

STEP 13

Put on Table Glass (O) to complete table

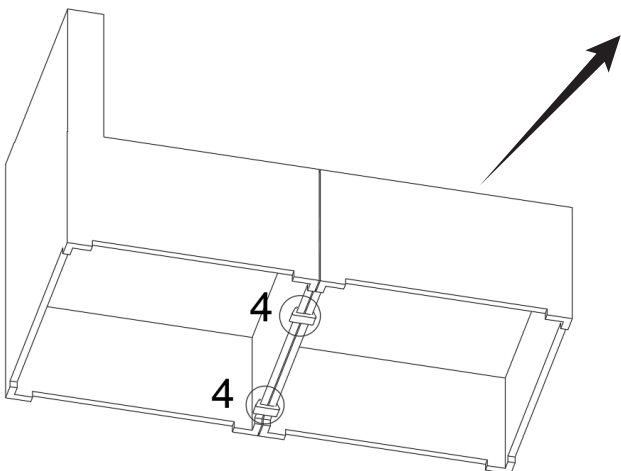
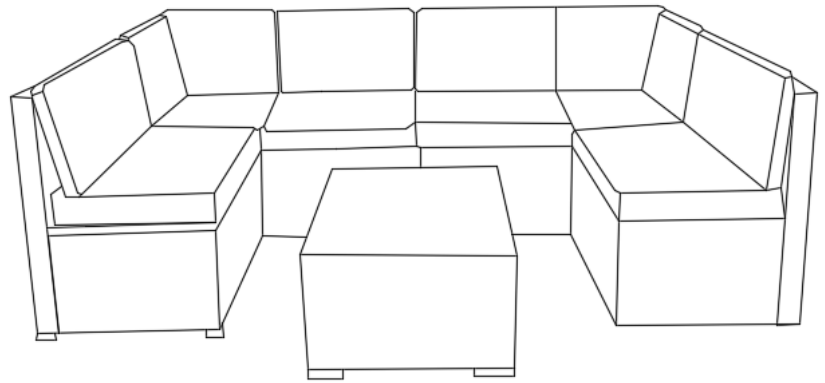
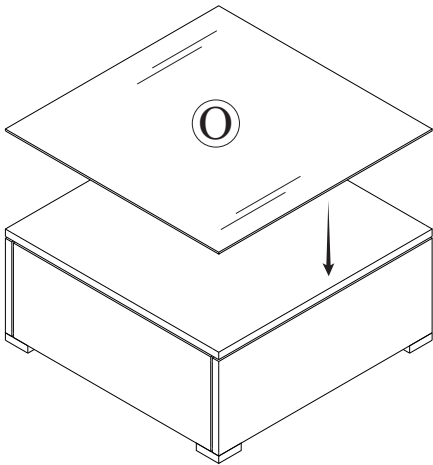

FINISH