



INSTRUCTIONS D'ASSEMBLAGE
ASSEMBLY INSTRUCTIONS

MONARCH
SPECIALTIES INC.

I 7436

BUREAU -
60" L / NOIR / DESSUS GRIS / METAL NOIR

COMPUTER DESK -
60" L / BLACK / GREY TOP / BLACK METAL



**POUR DE L'ASSISTANCE OU POUR COMMANDER
DES PIÈCES CONTACTEZ NOTRE DÉPARTEMENT
DE SERVICE À LA CLIENTÈLE.**

**FOR ASSISTANCE OR TO ORDER PARTS
CONTACT OUR CUSTOMER SERVICE DEPARTMENT**

WWW.MONARCHSERVICE.COM

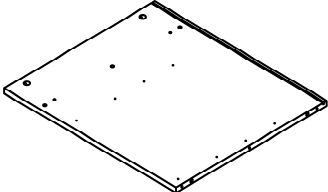
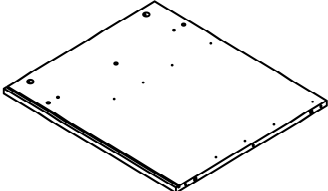
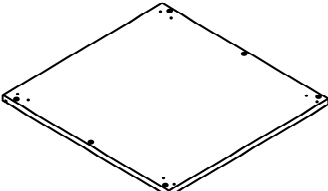
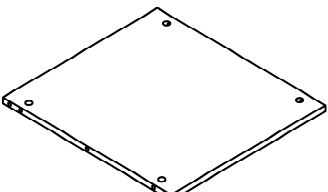
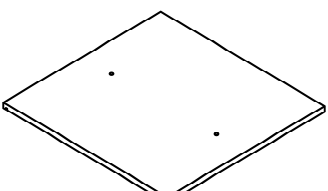

LISTE DES PIÈCES
PARTS LIST

PIÈCE / PART #	IMAGE	DESCRIPTION	QTY / QTÉ
1		FRONT FACING LEFT SIDE PANEL PANNEAU DE CÔTÉ GAUCHE	1
2		FRONT FACING RIGHT SIDE PANEL PANNEAU DE CÔTÉ AVANT DROIT	1
3		BOTTOM PANEL PANNEAU DU BAS	1
4		SHELF PANEL PANNEAU DE TABLETTE	1
5		TOP PANEL PANNEAU DE SURFACE	1

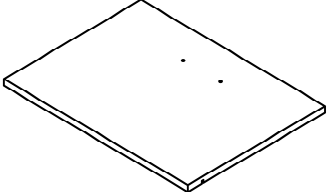
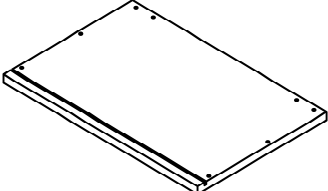
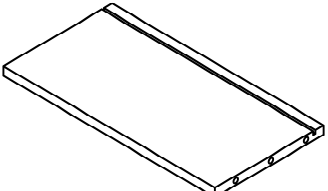
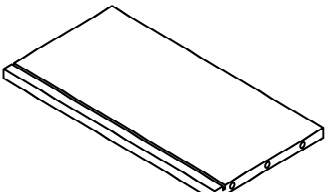
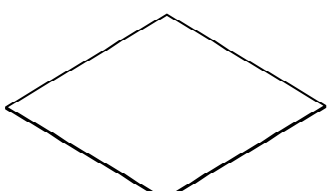
LISTE DES PIÈCES
PARTS LIST

PIÈCE / PART #	IMAGE	DESCRIPTION	QTY / QTÉ
6		DRAWER FRONT PANEL PANNEAU AVANT TIROIR	1
7		DRAWER BACK PANEL PANNEAU ARRIÈRE TIROIR	1
8		DRAWER SIDE PANEL PANNEAU DE CÔTÉ TIROIR	1
9		DRAWER SIDE PANEL PANNEAU DE CÔTÉ TIROIR	1
10		DRAWER BOTTOM PANEL PANNEAU DU BAS TIROIR	2

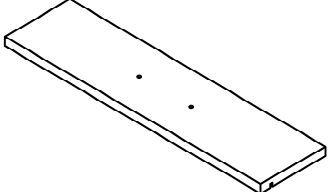
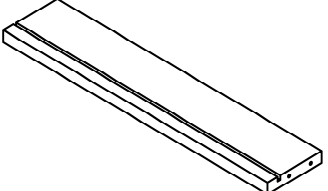
LISTE DES PIÈCES
PARTS LIST

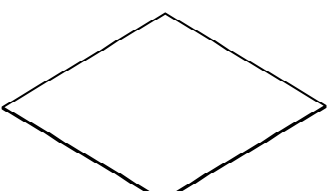
PIÈCE / PART #	IMAGE	DESCRIPTION	QTY / QTÉ
11		DRAWER FRONT PANEL PANNEAU AVANT TIROIR	1
12		DRAWER BACK PANEL PANNEAU ARRIÈRE TIROIR	1
13		DRAWER SIDE PANEL PANNEAU DE CÔTÉ TIROIR	1
14		DRAWER SIDE PANEL PANNEAU DE CÔTÉ TIROIR	1
15		BACK PANEL PANNEAU ARRIÈRE	1

LISTE DES PIÈCES
PARTS LIST

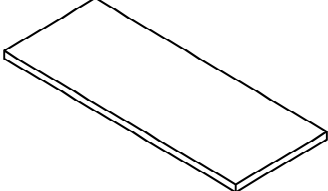
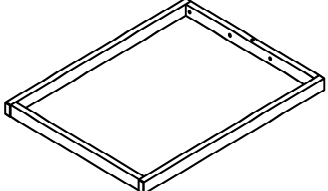
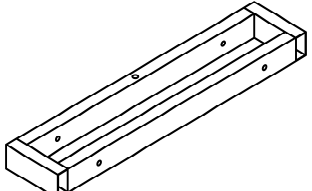
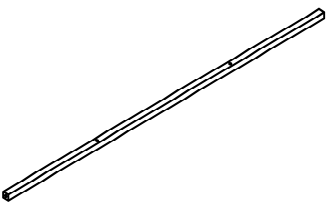
PIÈCE / PART #	IMAGE	DESCRIPTION	QTY / QTÉ
16		TABLE TOP SURFACE DE TABLE	1
17		METAL LEG PATTE EN METAL	1
18		METAL FRAME CADRE EN MÉTAL	1
19		SUPPORT BAR BARRE DE SOUTIEN	1

LISTE DES PIÈCES DE MONTAGE
HARDWARE LIST

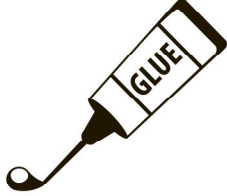
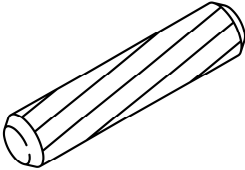
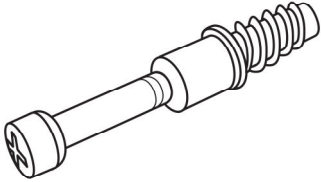
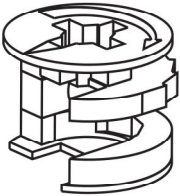
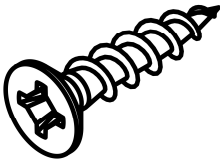
PIÈCE / PART #	IMAGE	DESCRIPTION	QTY / QTÉ
A		<p>GLUE - 15G</p> <p>COLLE - 15G</p>	1
B		<p>WOOD DOWEL - Ø3/8" X 1 1/8"</p> <p>GOUJON DE BOIS - Ø3/8" X 1 1/8"</p>	22
C		<p>CAM LOCK SCREW - 1 3/8"</p> <p>VIS CAM LOCK - 1 3/8"</p>	12
D		<p>CAM LOCK CONNECTOR - Ø5/8" X 1/2"</p> <p>ÉCROU CAM LOCK - Ø5/8" X 1/2"</p>	12
E		<p>ASSEMBLING SCREW - 1 3/8"</p> <p>VIS D'ASSEMBLAGE - 1 3/8"</p>	10

LISTE DES PIÈCES DE MONTAGE
HARDWARE LIST

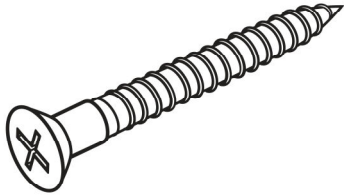
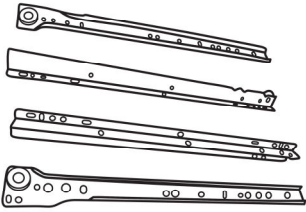
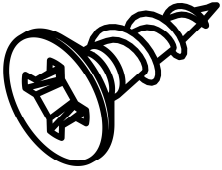
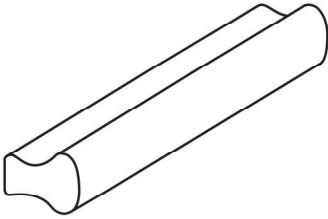
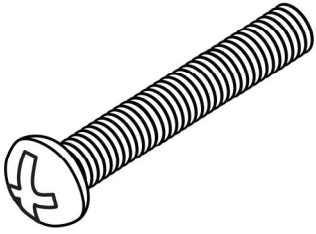
PIÈCE / PART #	IMAGE	DESCRIPTION	QTY / QTÉ
F		ASSEMBLING SCREW - 1 5/8" VIS D'ASSEMBLAGE - 1 5/8"	6
G		METAL DRAWER SLIDE - 15 3/4" COULISSE DE MÉTAL - 15 3/4"	2
H		ASSEMBLING SCREW - 1/2" VIS D'ASSEMBLAGE - 1/2"	28
I		HANDLE - 4 3/4" POIGNÉE - 4 3/4"	2
J		ASSEMBLING BOLT - 7/8" BOULON D'ASSEMBLAGE - 7/8"	4

LISTE DES PIÈCES DE MONTAGE
HARDWARE LIST

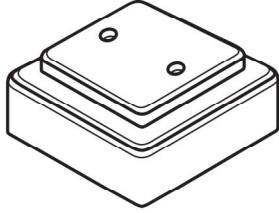
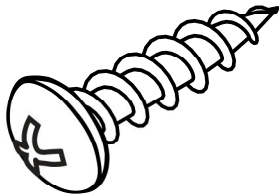
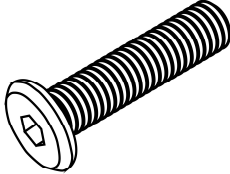
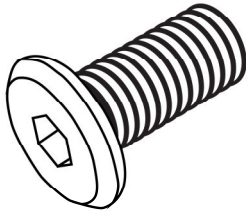
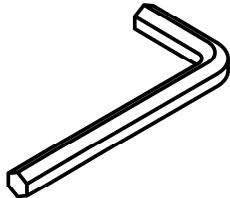
PIÈCE / PART #	IMAGE	DESCRIPTION	QTY / QTÉ
K		FLOOR PROTECTOR - 2" X 2" PROTECTEUR DE PLANCHER - 2" X 2"	4
L		ASSEMBLING SCREW - 7/8" VIS D'ASSEMBLAGE - 7/8"	8
M		ASSEMBLING BOLT - 2 1/2" BOULON D'ASSEMBLAGE - 2 1/2"	2
N		ASSEMBLING BOLT - 1 3/8" BOULON D'ASSEMBLAGE - 1 3/8"	8
O		HEX KEY CLÉ HEXAGONALE	1

LISTE DES PIÈCES DE MONTAGE
HARDWARE LIST

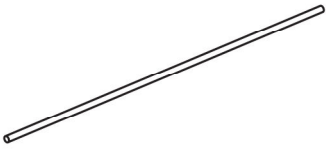
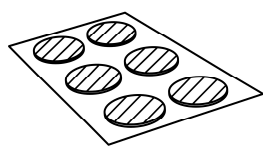
PIÈCE / PART #	IMAGE	DESCRIPTION	QTY / QTÉ
P		<p align="center">HANGING FOLDER BAR - 16" BARRE DE DOSSIER SUSPENDUE - 16"</p>	2
Q		<p align="center">FINISHING STICKER - Ø3/4" COLLANT DE FINITION - Ø3/4"</p>	12



OUTIL DE VÉRIFICATION DE DIMENSIONS DES PIÈCES
HARDWARE DIMENSIONS VERIFICATION TOOL



ÉTAPE / STEP 1

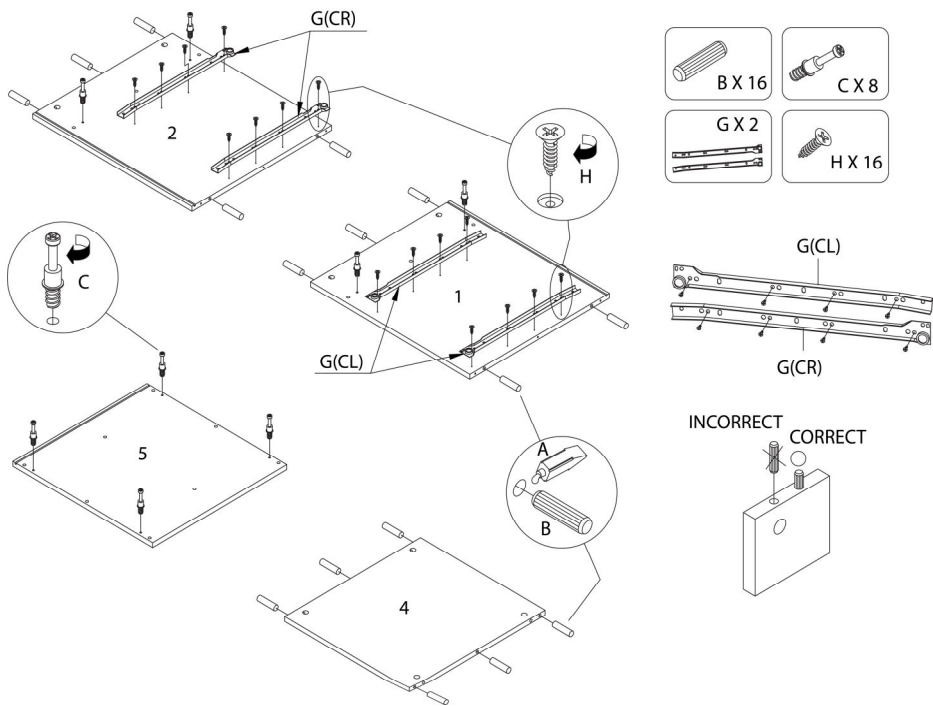

ÉTAPE / STEP 2

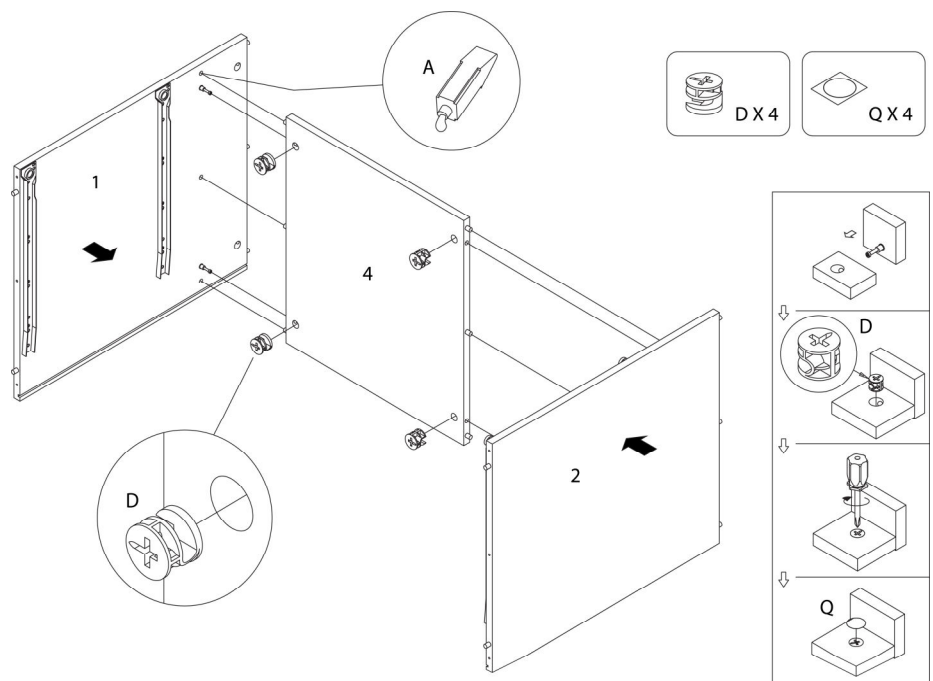

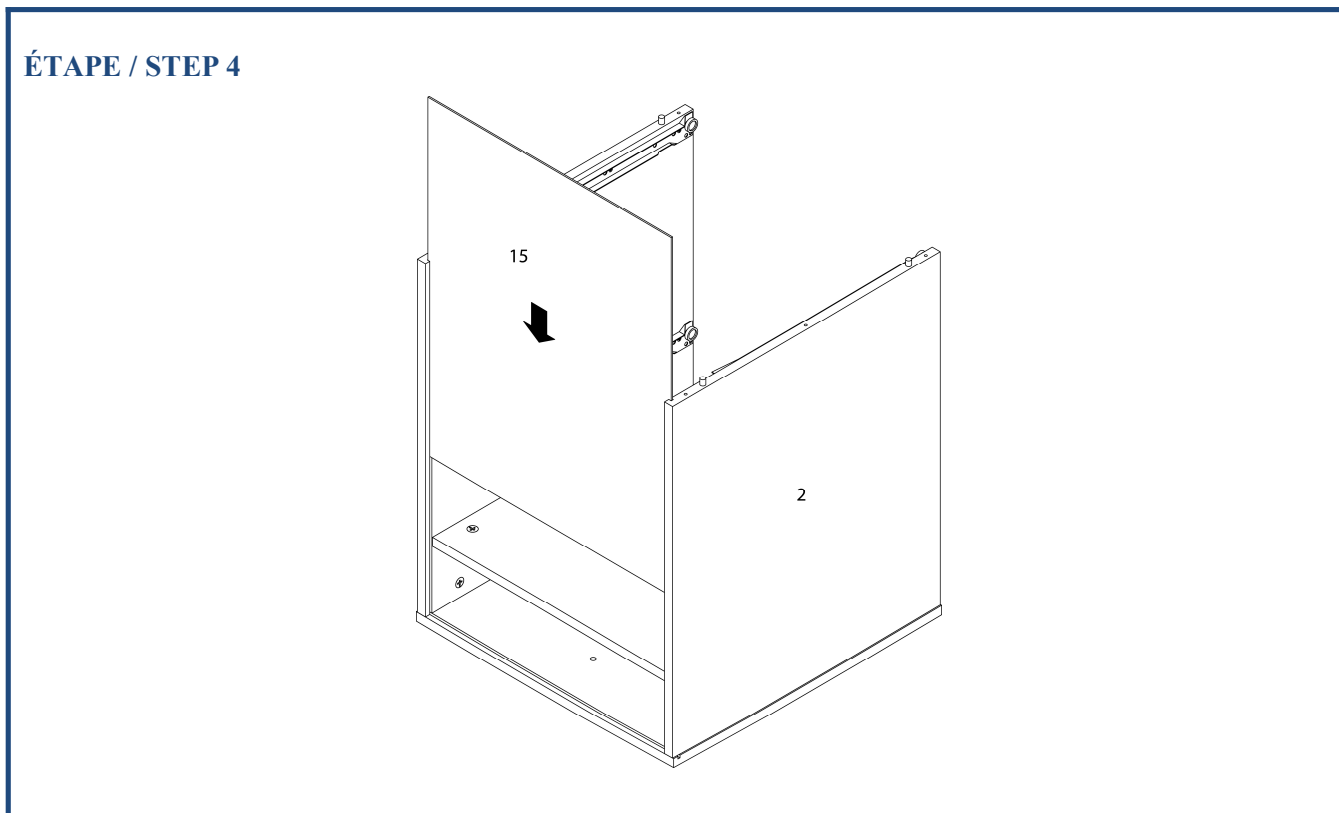
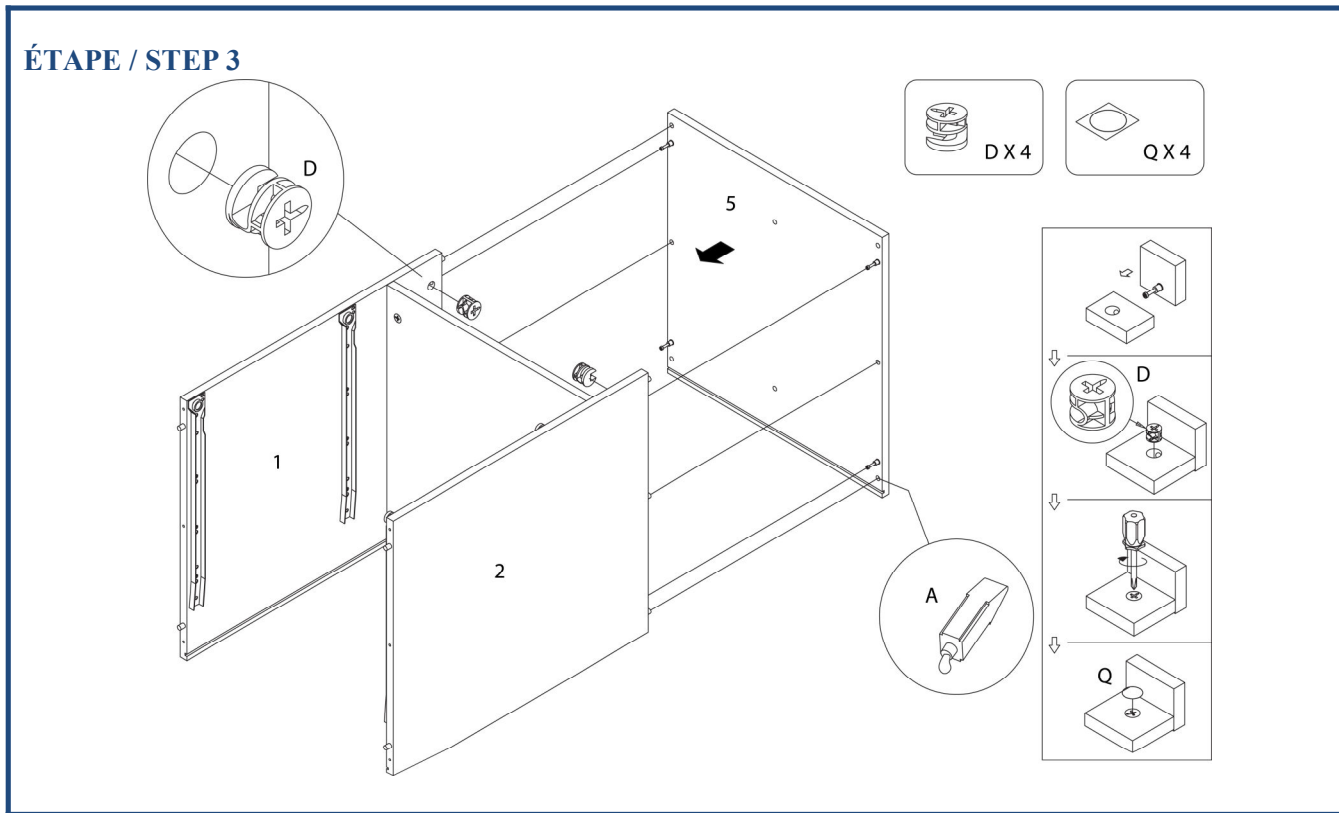

ÉTAPE / STEP 5

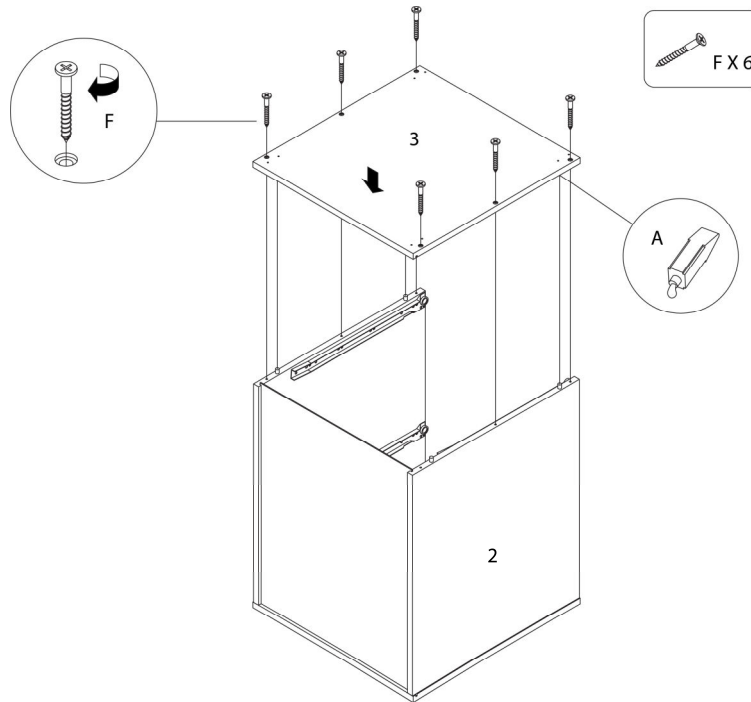

ÉTAPE / STEP 6

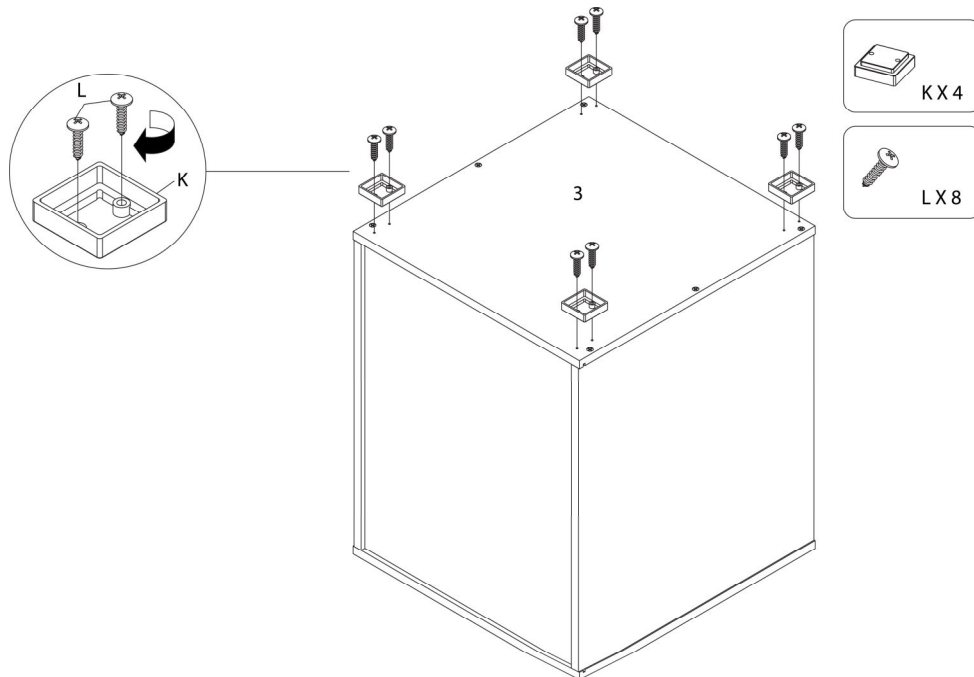

ÉTAPE / STEP 7

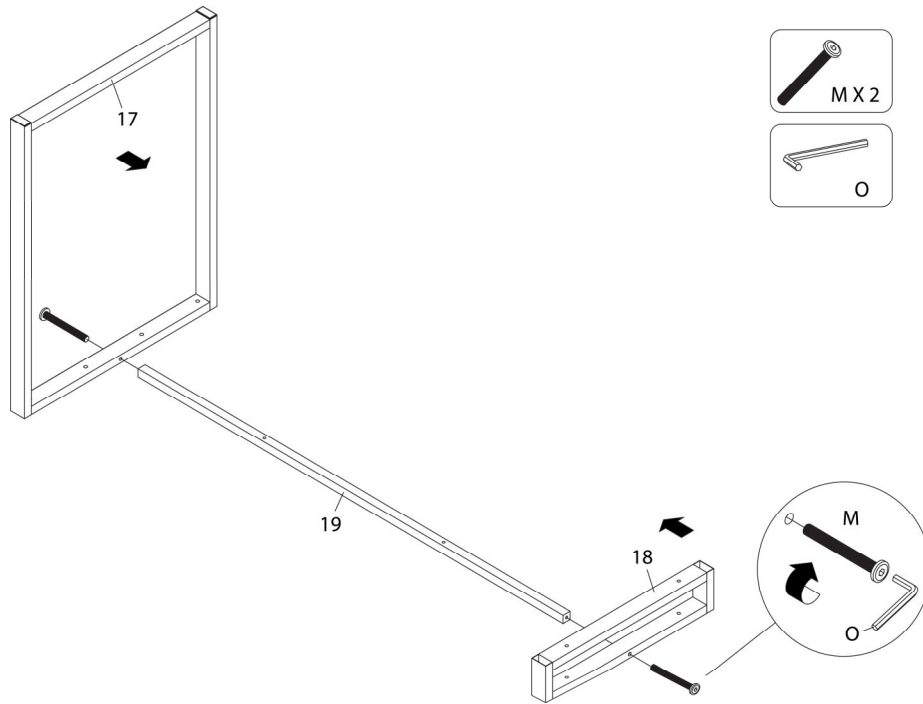

ÉTAPE / STEP 8

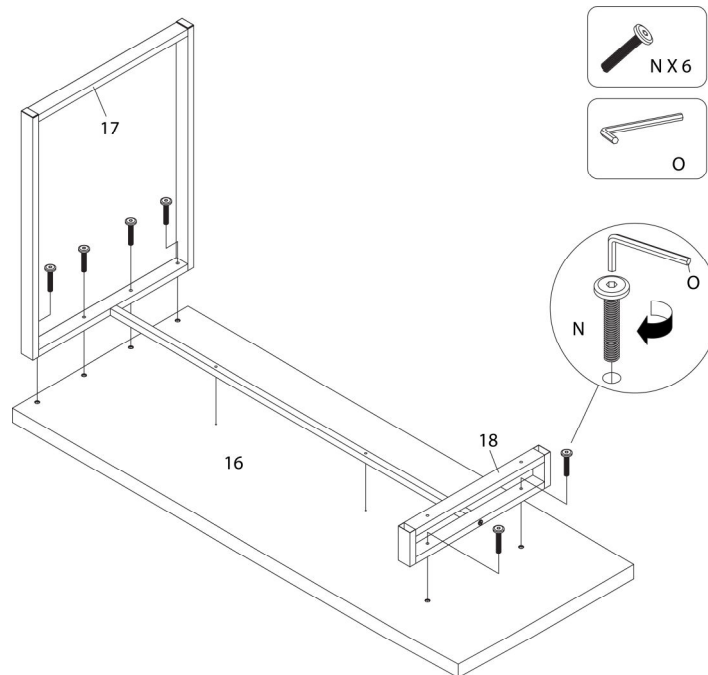

ÉTAPE / STEP 9

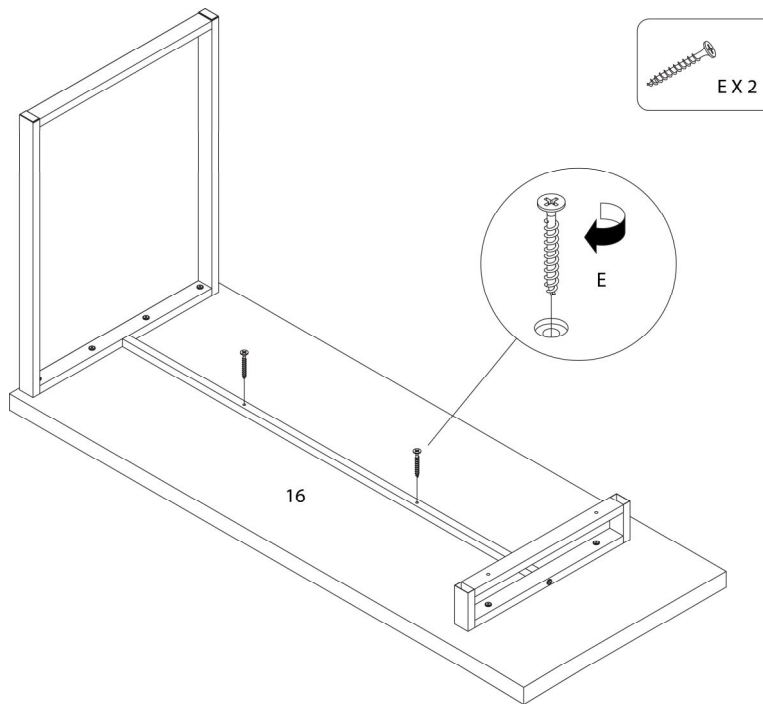

ÉTAPE / STEP 10

GAUCHE / LEFT

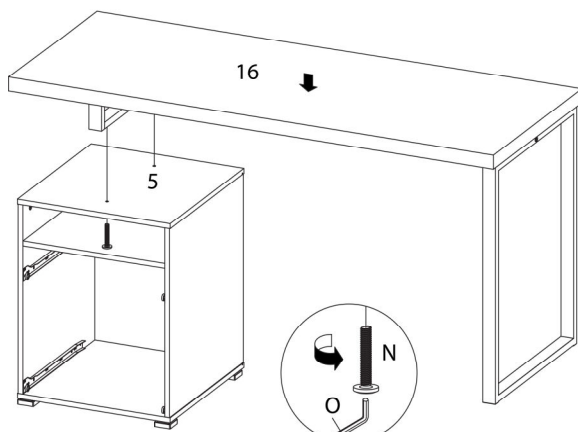

DROIT / RIGHT

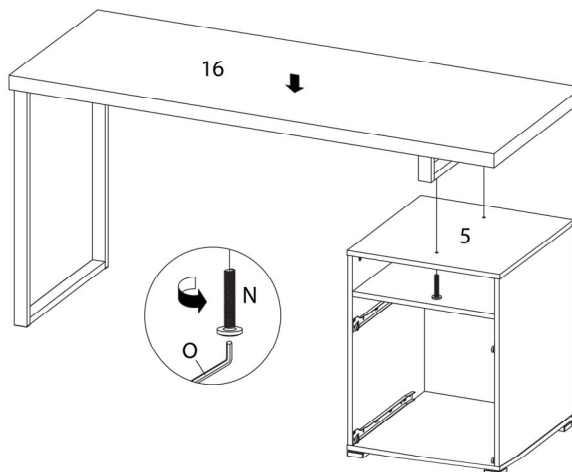

ÉTAPE / STEP 11

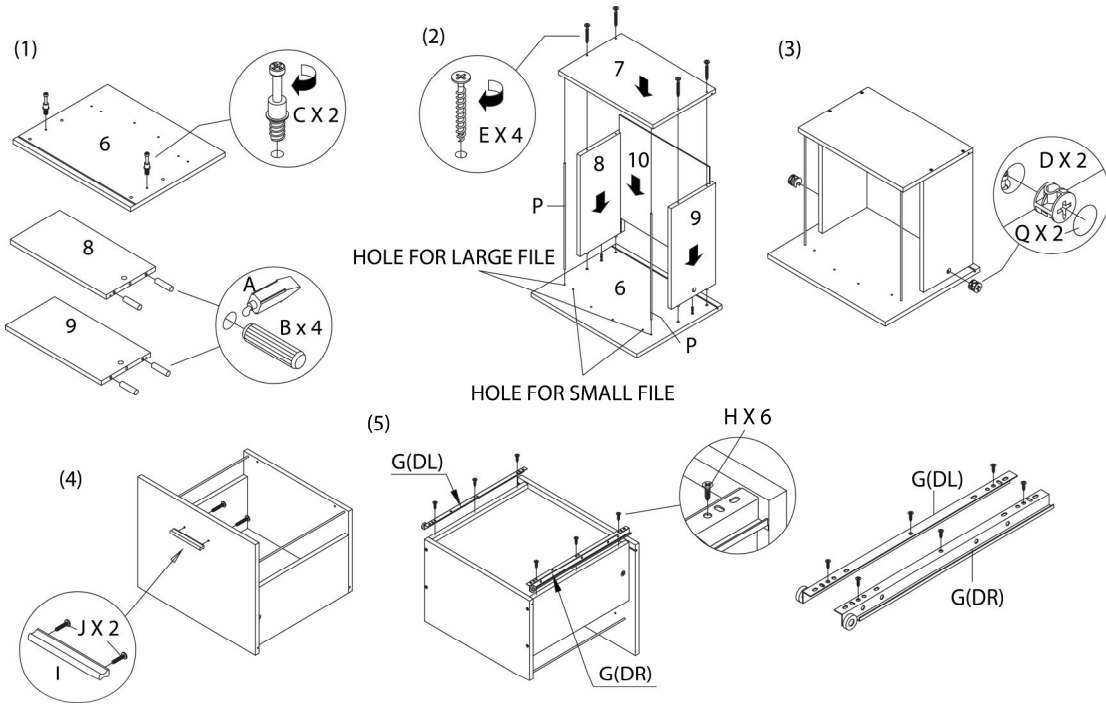

ÉTAPE / STEP 12

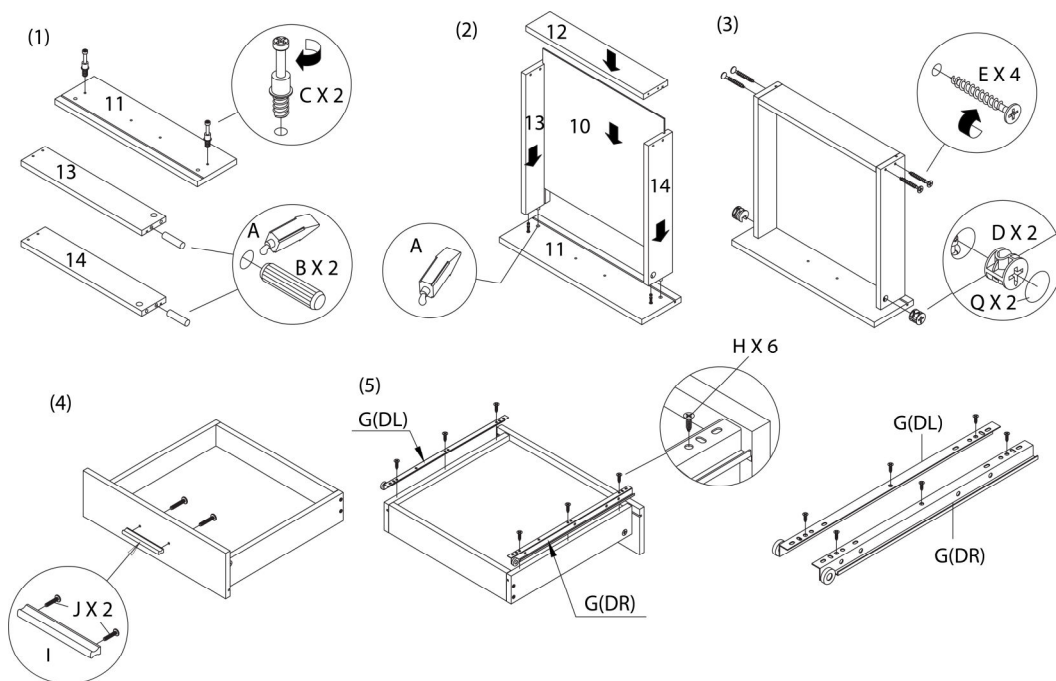

ÉTAPE / STEP 13

GAUCHE / LEFT

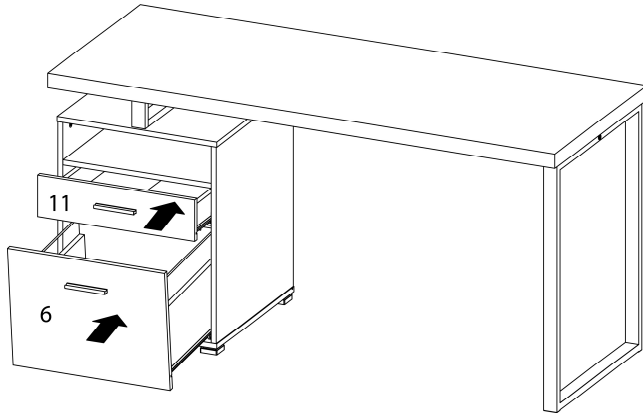

DROIT / RIGHT

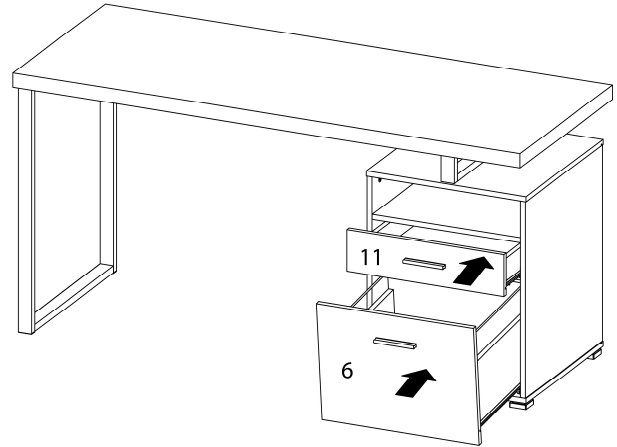

ÉTAPE / STEP 14

GAUCHE / LEFT

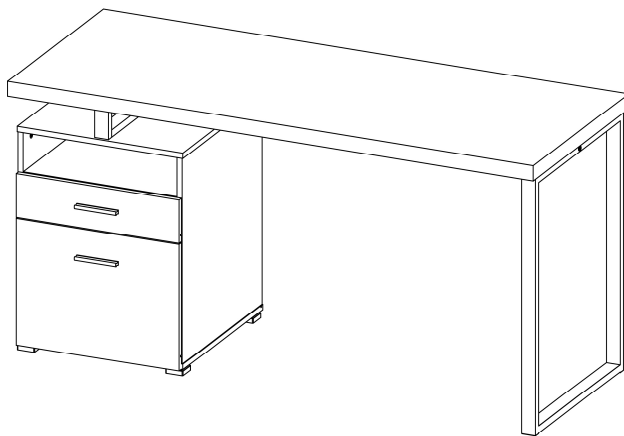

DROIT / RIGHT

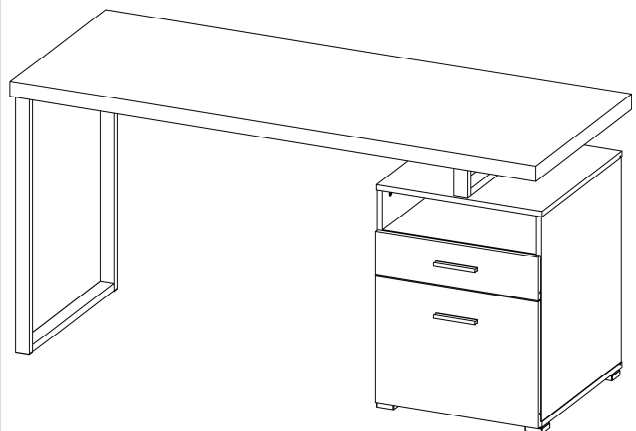

ÉTAPE / STEP 15

