



INSTRUCTIONS D'ASSEMBLAGE
ASSEMBLY INSTRUCTIONS

MONARCH
SPECIALTIES INC.

I 1345

TABLE A MANGER -
32"X 36" / BLANC HAUTEUR COMPTOIR

DINING TABLE -
32"X 36" / WHITE COUNTER HEIGHT



**POUR DE L'ASSISTANCE OU POUR COMMANDER
DES PIÈCES CONTACTEZ NOTRE DÉPARTEMENT
DE SERVICE À LA CLIENTÈLE.**

**FOR ASSISTANCE OR TO ORDER PARTS
CONTACT OUR CUSTOMER SERVICE DEPARTMENT**

WWW.MONARCHSERVICE.COM

LISTE DES PIÈCES
PARTS LIST

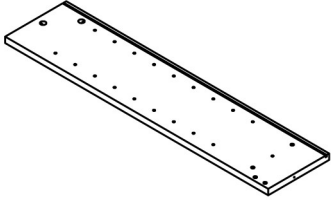
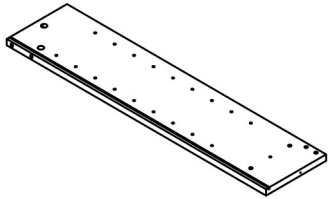
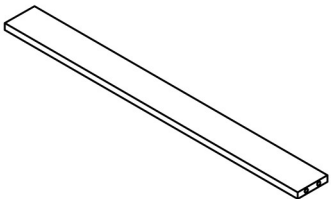
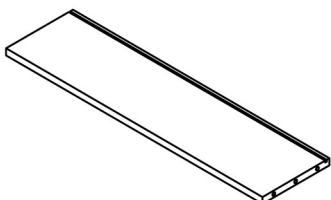
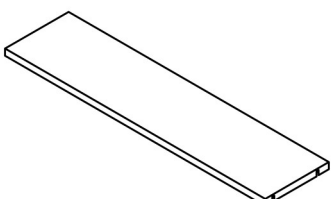
PIÈCE / PART #	IMAGE	DESCRIPTION	QTY / QTÉ
1		FRONT FACING LEFT SIDE PANEL PANNEAU DE CÔTÉ GAUCHE	1
2		FRONT FACING RIGHT SIDE PANEL PANNEAU DE CÔTÉ AVANT DROIT	1
3		SUPPORT PANEL PANNEAU DE SOUTIEN	1
4		BOTTOM SHELF ÉTAGÈRE DU BAS	1
5		SHELF PANEL PANNEAU DE TABLETTE	2

LISTE DES PIÈCES
PARTS LIST

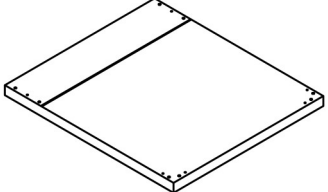
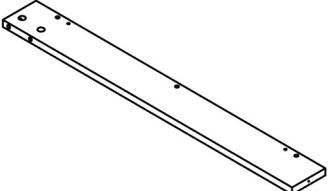
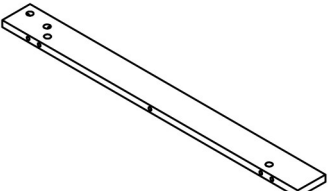
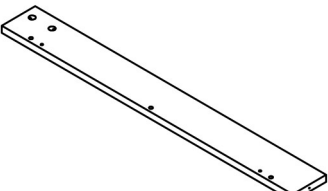
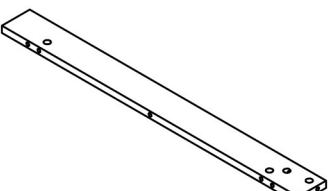
PIÈCE / PART #	IMAGE	DESCRIPTION	QTY / QTÉ
6		TOP PANEL PANNEAU DE SURFACE	1
7		TABLE LEG PATTE DE TABLE	1
8		TABLE LEG PATTE DE TABLE	1
9		TABLE LEG PATTE DE TABLE	1
10		TABLE LEG PATTE DE TABLE	1

LISTE DES PIÈCES
PARTS LIST

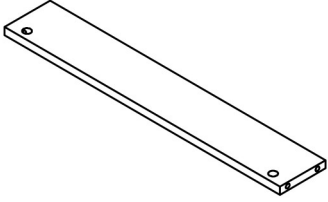
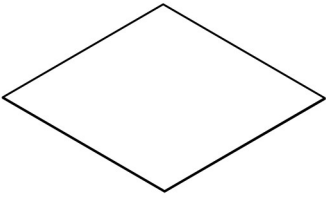
PIÈCE / PART #	IMAGE	DESCRIPTION	QTY / QTÉ
11		CROSSBAR BARRE TRANSVERSALE	3
12		BACK PANEL PANNEAU ARRIÈRE	1

LISTE DES PIÈCES DE MONTAGE
HARDWARE LIST

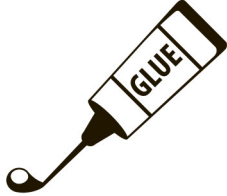
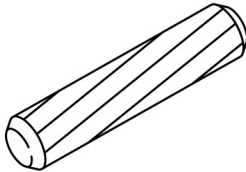
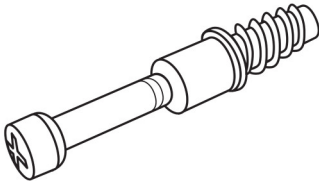
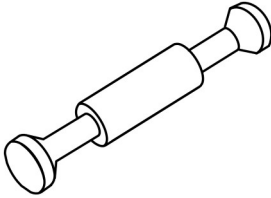
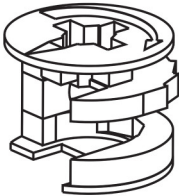
PIÈCE / PART #	IMAGE	DESCRIPTION	QTY / QTÉ
A		GLUE COLLE	1
B		WOOD DOWEL - Ø3/8" X 1 1/8" GOUJON DE BOIS - Ø3/8" X 1 1/8"	28
C		CAM LOCK SCREW - 1 3/8" VIS CAM LOCK - 1 3/8"	12
D		CAM LOCK CONNECTOR - 2 1/2" ÉCROU CAM LOCK - 2 1/2"	6
E		CAM LOCK CONNECTOR - Ø5/8" X 1/2" ÉCROU CAM LOCK - Ø5/8" X 1/2"	24

LISTE DES PIÈCES DE MONTAGE
HARDWARE LIST

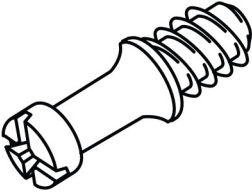
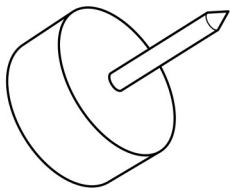
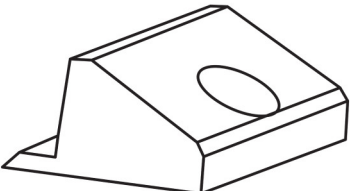
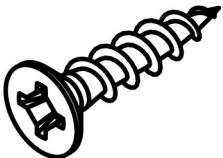
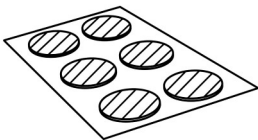
PIÈCE / PART #	IMAGE	DESCRIPTION	QTY / QTÉ
F		CAM LOCK SCREW - 7/8" VIS CAM LOCK - 7/8"	8
G		FLOOR PROTECTOR - Ø3/4" PROTECTEUR DE PLANCHER - Ø3/4"	8
H		SUPPORT - 5/8" X 5/8" SUPPORT - 5/8" X 5/8"	4
I		ASSEMBLING SCREW - 3/4" VIS D'ASSEMBLAGE - 3/4"	4
J		FINISHING STICKER - Ø3/4" COLLANT DE FINITION - Ø3/4"	24

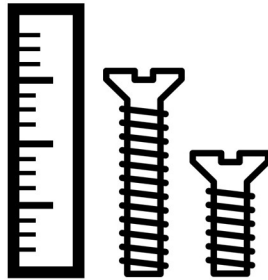

OUTIL DE VÉRIFICATION DE DIMENSIONS DES PIÈCES
HARDWARE DIMENSIONS VERIFICATION TOOL

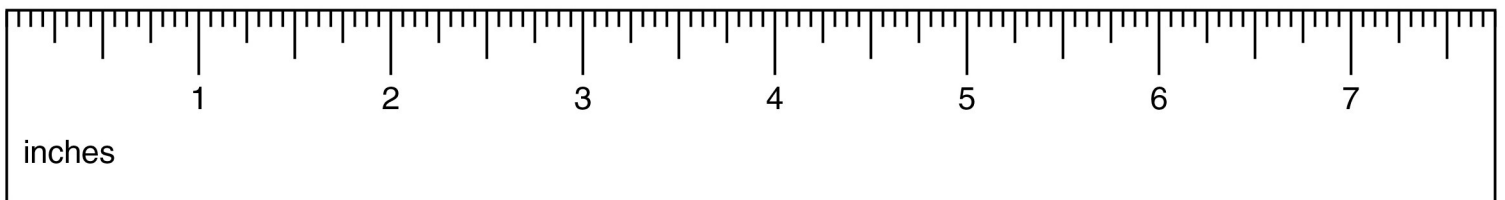

ÉTAPE / STEP 1

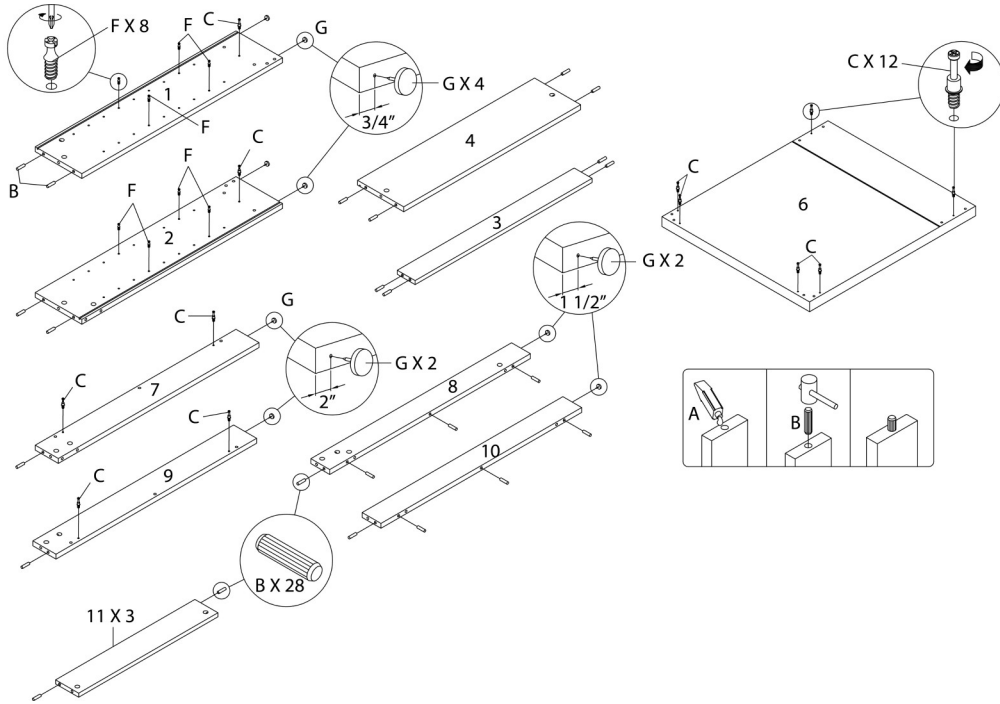

ÉTAPE / STEP 2

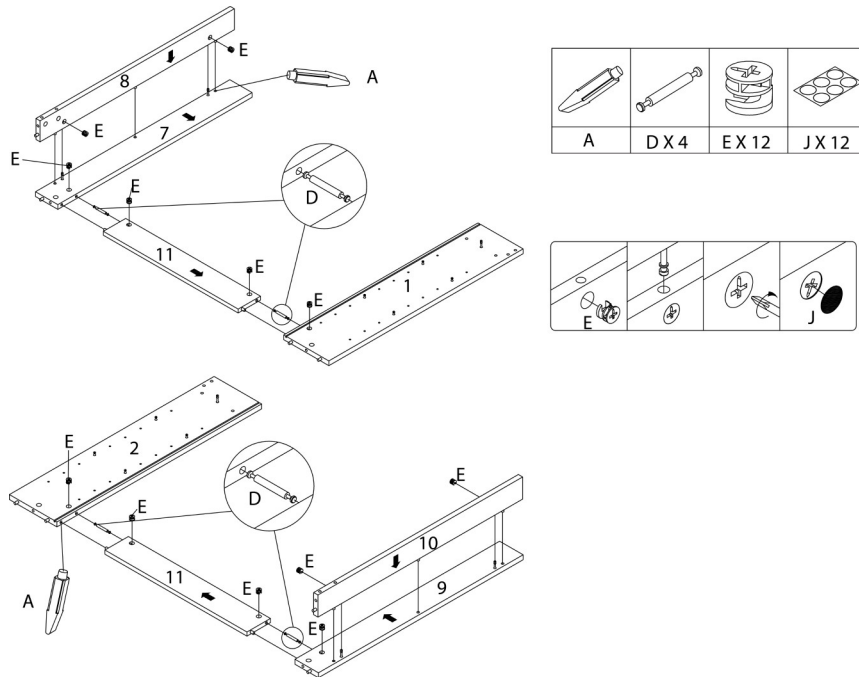

ÉTAPE / STEP 3

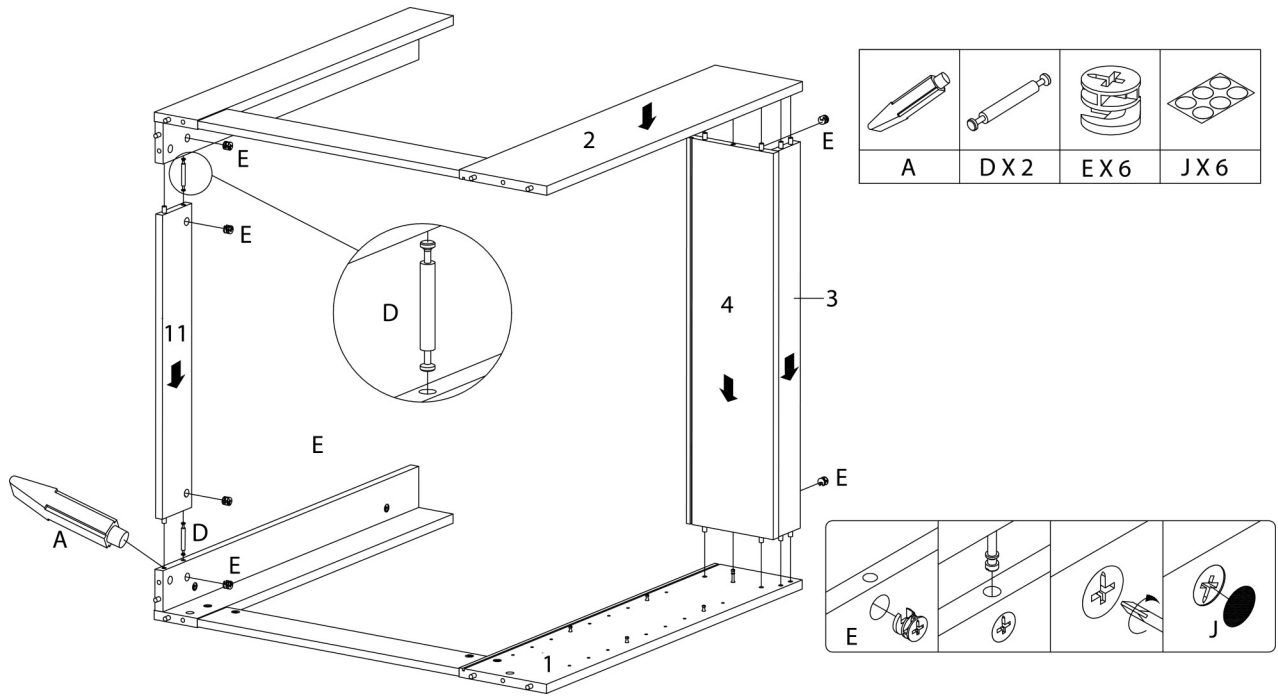

ÉTAPE / STEP 4

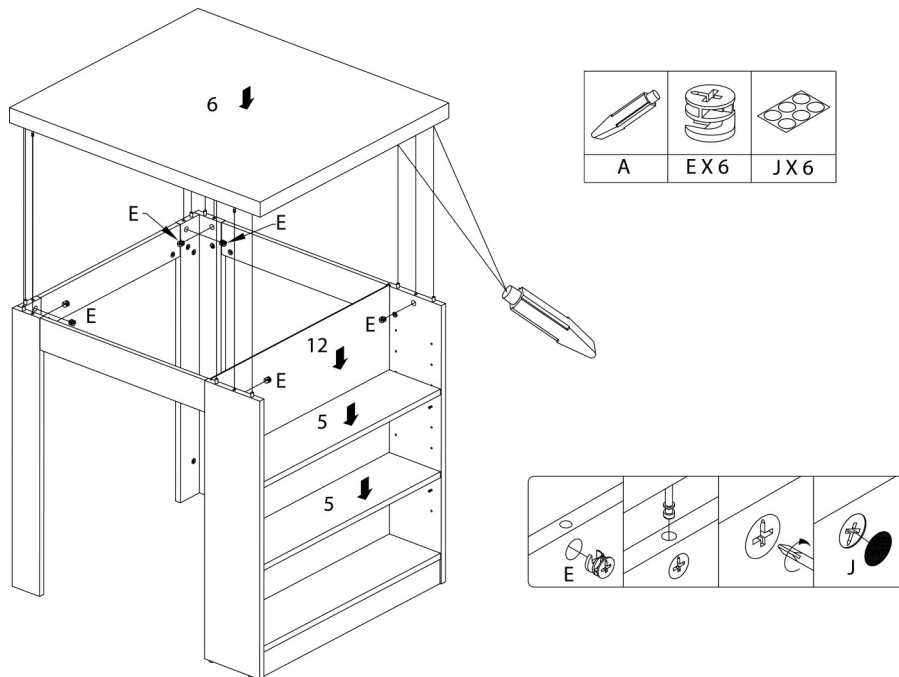

ÉTAPE / STEP 5

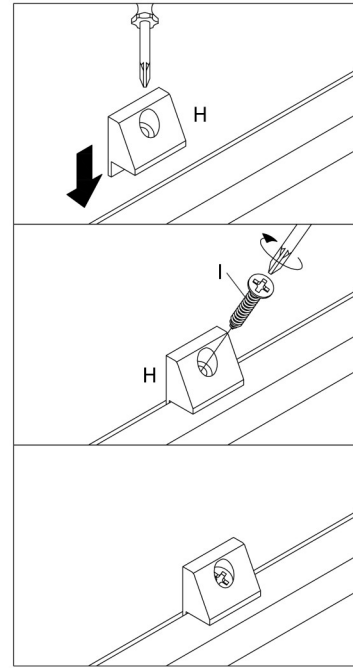
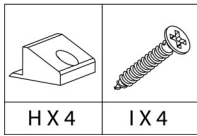
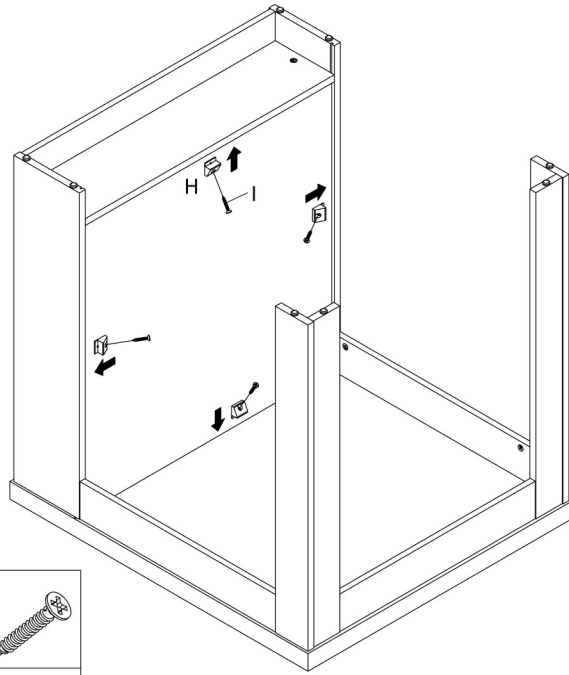

ÉTAPE / STEP 6

