



**INSTRUCTIONS D'ASSEMBLAGE**  
**ASSEMBLY INSTRUCTIONS**

---

**M**ONARCH  
SPECIALTIES INC.

**I 7269**

---

**CHAISE DE BUREAU -**  
**BLANC/MECHE GRIS/ DOSSIER-HAUT CHROME**

**OFFICE CHAIR -**  
**WHITE / GREY MESH / CHROME HIGH-BACK EXEC**



**POUR DE L'ASSISTANCE OU POUR COMMANDER**  
**DES PIÈCES CONTACTEZ NOTRE DÉPARTEMENT**  
**DE SERVICE À LA CLIENTÈLE.**



**FOR ASSISTANCE OR TO ORDER PARTS**  
**CONTACT OUR CUSTOMER SERVICE DEPARTMENT**

**WWW.MONARCHSERVICE.COM**

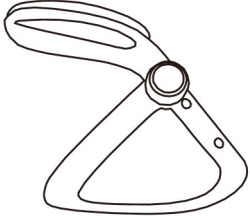
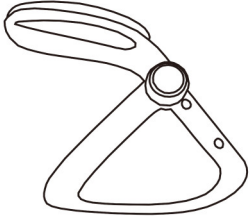
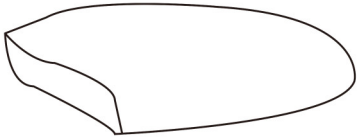
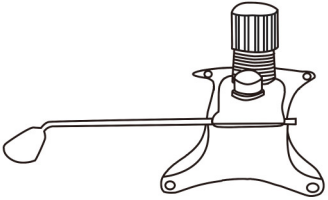
**LISTE DES PIÈCES**  
**PARTS LIST**

| PIÈCE / PART # | IMAGE   | DESCRIPTION  | QTY / QTÉ |
|----------------|---|--|-----------|
| 1              |    | <p><b>BACK REST</b><br/> <b>DOSSIER</b></p>                                | 1         |
| 2              |    | <p><b>FRONT FACING LEFT ARMREST</b><br/> <b>ACCOUDOIR AVANT GAUCHE</b></p> | 1         |
| 3              |  | <p><b>FRONT FACING RIGHT ARMREST</b><br/> <b>ACCOUDOIR AVANT DROIT</b></p> | 1         |
| 4              |  | <p><b>CHAIR SEAT</b><br/> <b>SIÈGE</b></p>                                 | 1         |
| 5              |  | <p><b>CHAIR MECHANISM SEAT PLATE</b><br/> <b>MÉCANISME DE SIÈGE</b></p>    | 1         |

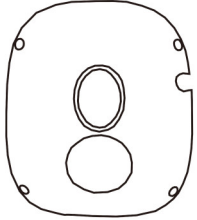
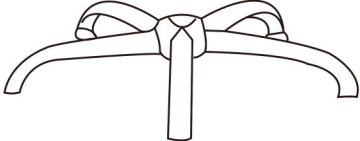
**LISTE DES PIÈCES**  
**PARTS LIST**

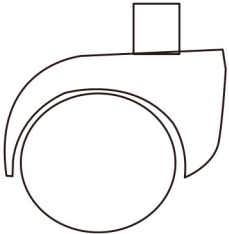
| PIÈCE / PART # | IMAGE   | DESCRIPTION   | QTY / QTÉ |
|----------------|---|---|-----------|
| 6              |    | <p>SEAT COVER<br/>HOUSSE DE SIÈGE</p>                                     | 1         |
| 7              |    | <p>BASE<br/>BASE</p>  | 1         |
| 8              |  | <p>GASLIFT<br/>ASCENSEUR À ESSENCE</p>                                    | 1         |
| 9              |  | <p>TELESCOPIC COLUMN COVER<br/>COUVERTURE DE COLONNE<br/>TÉLÉSCOPIQUE</p> | 1         |
| 10             |  | <p>CASTOR<br/>ROULLETTE</p>   | 5         |

**LISTE DES PIÈCES**  
**PARTS LIST**

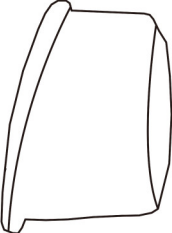
| PIÈCE / PART # | IMAGE   | DESCRIPTION                  | QTY / QTÉ |
|----------------|---|------------------------------|-----------|
| 11             |  | SCREW CAP<br>CAPUCHON DE VIS | 4         |

**LISTE DES PIÈCES DE MONTAGE**  
**HARDWARE LIST**

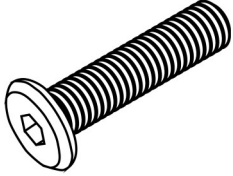
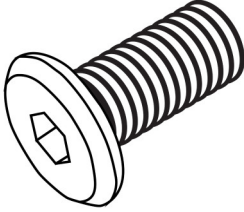
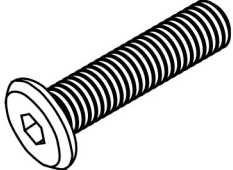
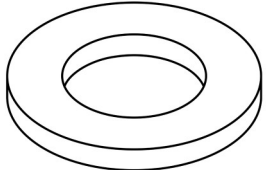
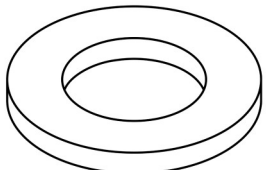
| PIÈCE / PART # | IMAGE   | DESCRIPTION  | QTY / QTÉ |
|----------------|---|--|-----------|
| A              |    | ASSEMBLING BOLT -<br>Ø 1/4" X 1 1/2"<br>BOULON D'ASSEMBLAGE -<br>Ø 1/4" X 1 1/2" | 4         |
| B              |    | ASSEMBLING BOLT -<br>Ø 1/4" X 3/4"<br>BOULON D'ASSEMBLAGE -<br>Ø 1/4" X 3/4"     | 6         |
| C              |  | ASSEMBLING BOLT -<br>Ø 1/4" X 1 1/8"<br>BOULON D'ASSEMBLAGE -<br>Ø 1/4" X 1 1/8" | 2         |
| D              |  | METAL WASHER -<br>Ø 1/4" X 1/2"<br>RONDELLE DE MÉTAL -<br>Ø 1/4" X 1/2"          | 4         |
| E              |  | METAL WASHER -<br>Ø 1/4" X 3/4"<br>RONDELLE DE MÉTAL -<br>Ø 1/4" X 3/4"          | 8         |

**LISTE DES PIÈCES DE MONTAGE**  
**HARDWARE LIST**

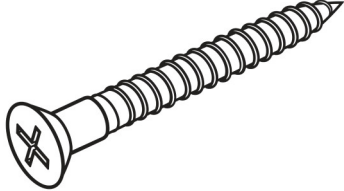
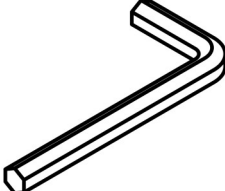
| PIÈCE / PART # | IMAGE   | DESCRIPTION  | QTY / QTÉ |
|----------------|---|--|-----------|
| F              |  | ASSEMBLING SCREW -<br>Ø 1/4 X 5/8"<br>VIS D'ASSEMBLAGE -<br>Ø 1/4 X 5/8" | 4         |
| G              |  | HEX KEY<br>CLÉ HEXAGONALE  | 1         |

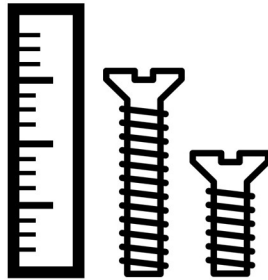

OUTIL DE VÉRIFICATION DE DIMENSIONS DES PIÈCES  
HARDWARE DIMENSIONS VERIFICATION TOOL

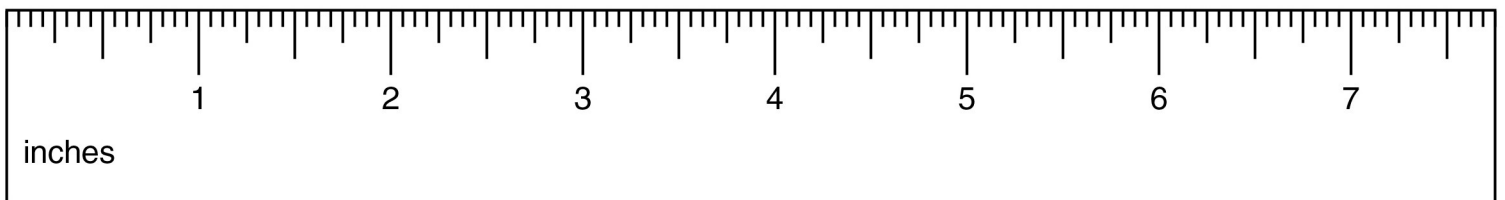

ÉTAPE / STEP 1

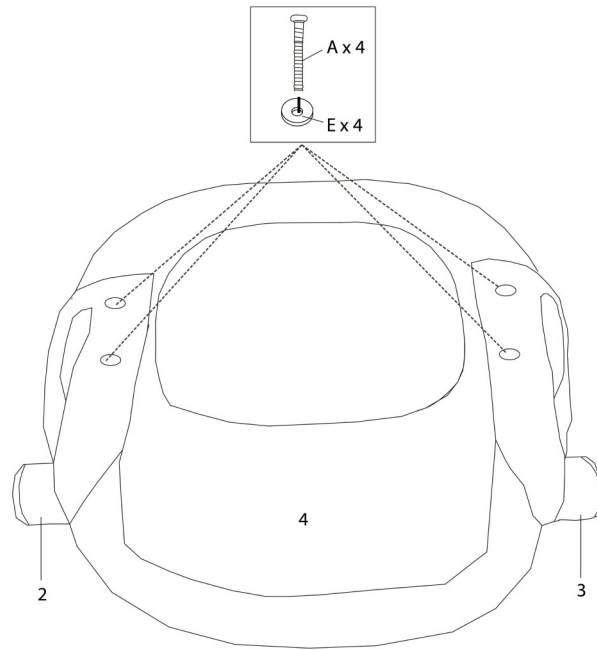

ÉTAPE / STEP 2

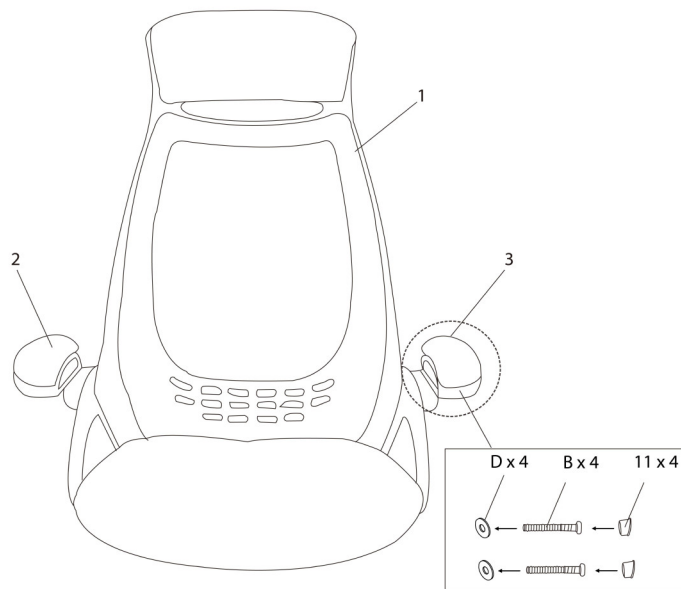



ÉTAPE / STEP 3

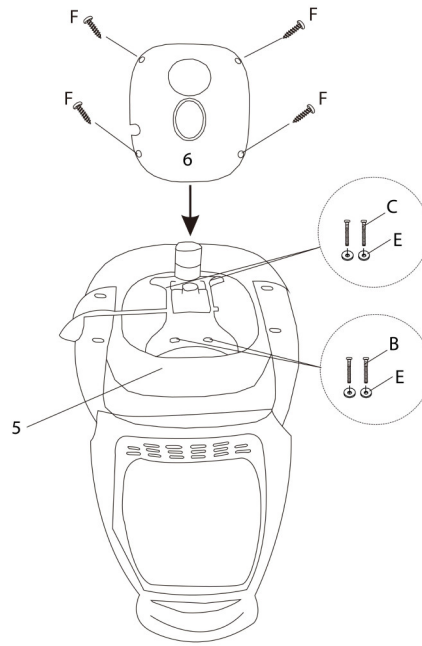

ÉTAPE / STEP 4

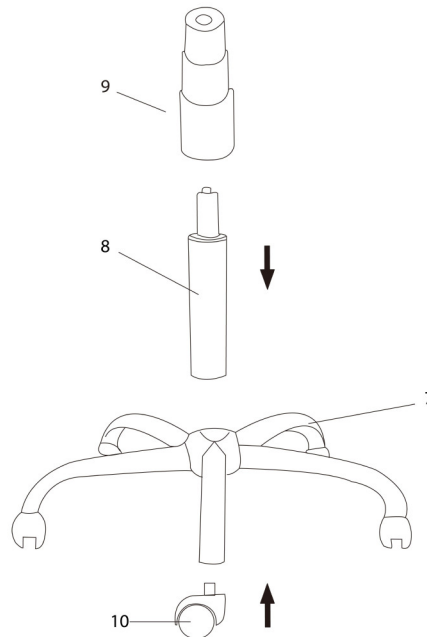

ÉTAPE / STEP 5

