

Wellington

Model # 5863

Wellington Tall Planter



DESCRIPTION

Enjoy the look of wicker without the risk of weather damage with the Mayne Wellington Tall Planter. The Beautiful wicker design adds a charming touch to any patio or deck!

- Single wall molded design
- Weather resistant, low maintenance material
- 100% high-grade polyethylene planter with UV inhibitors
- Warranty: 15-Yr Residential Use / 5-Yr Commercial Use

PRODUCT DIMENSIONS

Outside Dimensions: 16in L x 16in W x 28in H (40.6cm x 40.6cm x 71.1cm)

Inside Dimensions: 11.7in L x 11.7in W x 27.7in D (29.8cm x 29.8cm x 70.2cm)

Soil Capacity: 15 Gallons (56.8 Liters)

Wall Thickness: 0.15in (3.8mm)

Part Weight: 10lbs (4.5kg)

Material: Polyethylene

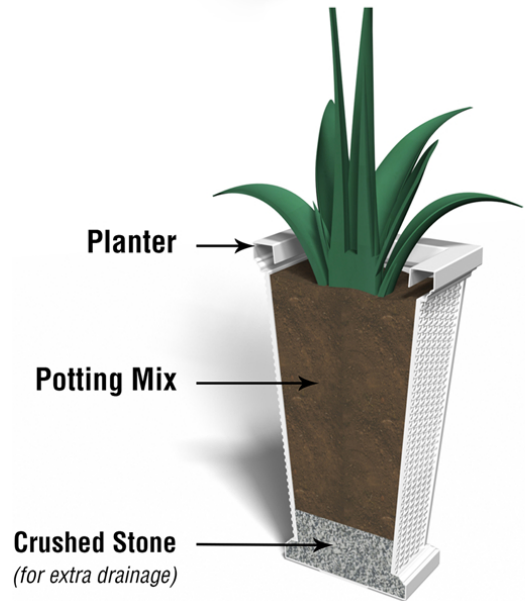
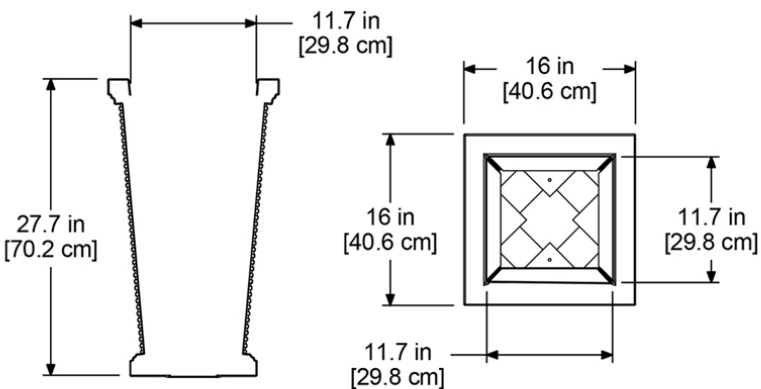
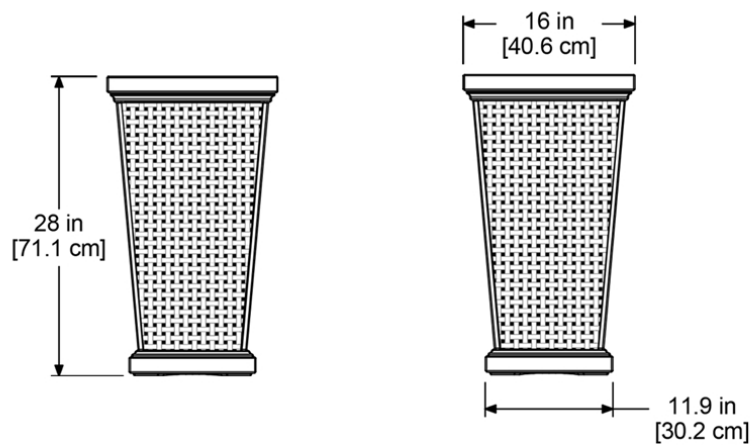

MAYNE[®]
Outdoor Products of Distinction

7024 Kilbourne Rd - Unit A London, ON N6P 1K6

Tel: 866-363-8834 | www.gomayne.com

customerservice@gomayne.com