

Freeport

Model # 5860

Freeport 18in Patio Planter



DESCRIPTION

Modern design and clean lines is the best way to describe our Freeport planter. This fresh design provides a great finishing touch to your outdoor space. Perfect for the more urban setting, this planter features a double wall design and sub irrigation watering system making it functional as well as beautiful.

- Molded polyethylene planter with UV inhibitors
- Weather resistant, low maintenance material
- Features a double wall design creating a water reservoir
- Warranty: 15-Yr Residential Use / 5-Yr Commercial Use

PRODUCT DIMENSIONS

Outside Dimensions: 18in L x 18in W x 20in H (45.7cm x 45.7cm x 50.8cm)

Inside Dimensions: 13.9in L x 13.9in W x 13.5in D (35.4cm x 35.4cm x 34.3cm)

Soil Capacity: 8 Gallons (30.3 Liters)

Water Reservoir Capacity: 6.5 Gallons (24.6 Liters)

Wall Thickness: 0.12in (3mm)

Part Weight: 11lbs (5.0kg)

Material: Polyethylene

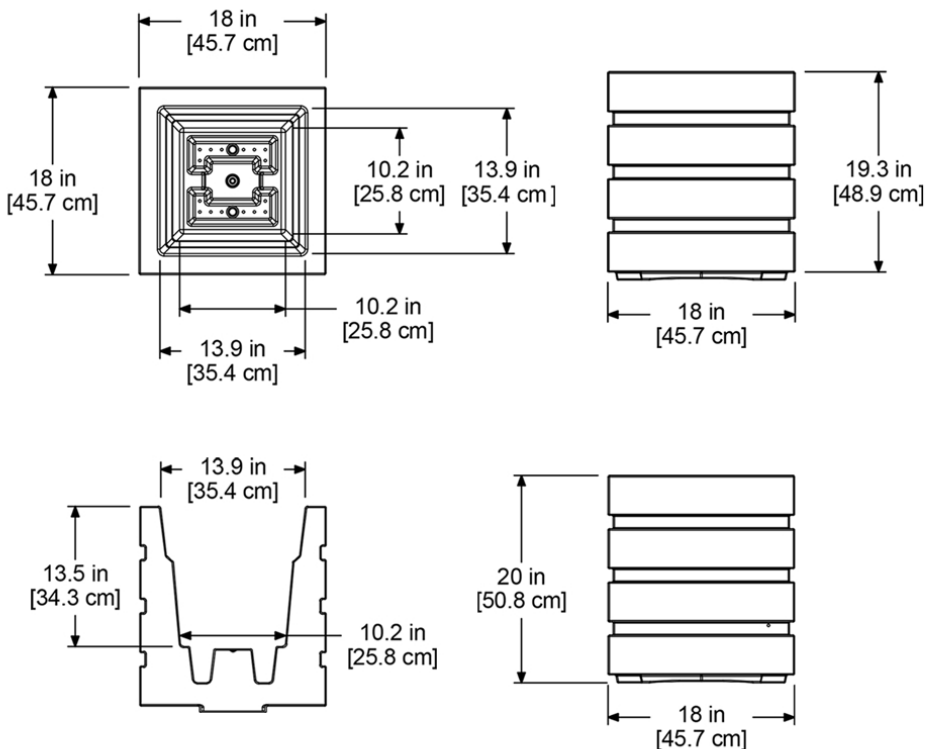
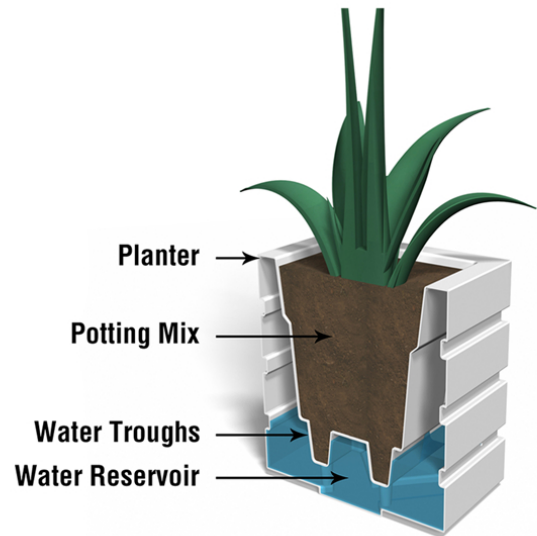

MAYNE[®]
Outdoor Products of Distinction

7024 Kilbourne Rd - Unit A London, ON N6P 1K6
Tel: 866-363-8834 | www.gomayne.com
customerservice@gomayne.com