



**INSTRUCTIONS D'ASSEMBLAGE**  
**ASSEMBLY INSTRUCTIONS**

---

**M**ONARCH  
SPECIALTIES INC.

**I 8322**

---

**CHAISE D'APPOINT -**  
**ENS. 2PCS / GEOMETRIQUE GRIS PALE**

**ACCENT CHAIR -**  
**2PCS SET / LIGHT GREY GEOMETRIC FABRIC**







**POUR DE L'ASSISTANCE OU POUR COMMANDER**  
**DES PIÈCES CONTACTEZ NOTRE DÉPARTEMENT**  
**DE SERVICE À LA CLIENTÈLE.**

**FOR ASSISTANCE OR TO ORDER PARTS**  
**CONTACT OUR CUSTOMER SERVICE DEPARTMENT**

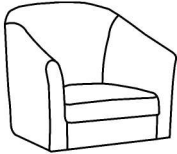
**WWW.MONARCHSERVICE.COM**

**LISTE DES PIÈCES**  
**PARTS LIST**

PIÈCE / PART #	IMAGE	DESCRIPTION	QTY / QTÉ
1		SEAT SIÈGE	1
2		CHAIR LEG (FRONT) PATTE DE CHAISE (AVANT)	2
3		CHAIR LEG PATTE DE CHAISE	2
4		OTTOMAN POUF	1
5		LEG PATTE	4

**LISTE DES PIÈCES DE MONTAGE**  
**HARDWARE LIST**

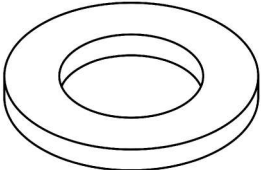
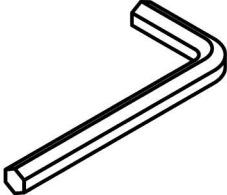
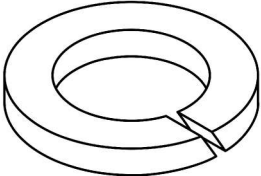
PIÈCE / PART #	IMAGE	DESCRIPTION	QTY / QTÉ
A		<p align="center">ASSEMBLING BOLT -            Ø 1/2" X 1 5/8"            BOULON D'ASSEMBLAGE -            Ø 1/2" X 1 5/8"</p>	8
B		<p align="center">METAL WASHER            RONDELLE DE MÉTAL</p>	8
C		<p align="center">HEX KEY            CLÉ HEXAGONALE</p>	1
D		<p align="center">LOCK WASHER            ENTRETOISE DE MÉTAL</p>	8

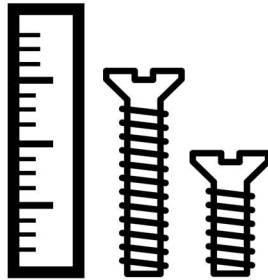

OUTIL DE VÉRIFICATION DE DIMENSIONS DES PIÈCES  
HARDWARE DIMENSIONS VERIFICATION TOOL

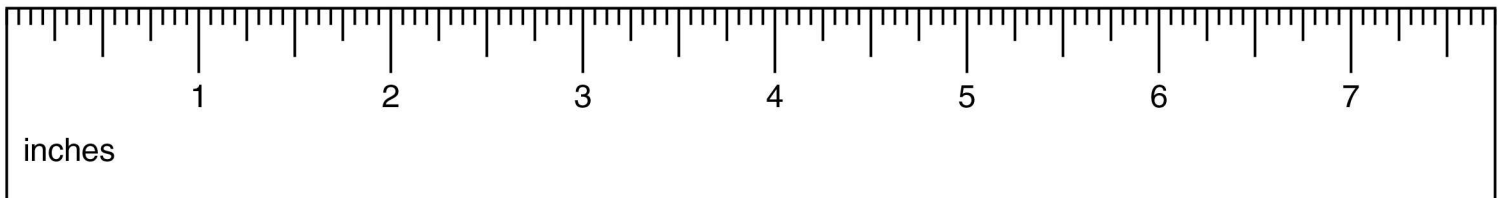

ÉTAPE / STEP 1

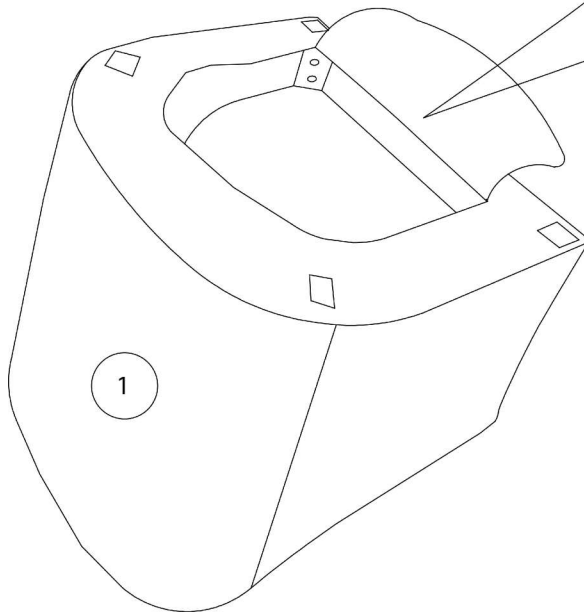

La quincaillerie et les pattes sont  
entreposées dans le compartiment  
en-dessous de l'unité.

Hardware and legs are located in the  
compartment under the unit

ÉTAPE / STEP 2

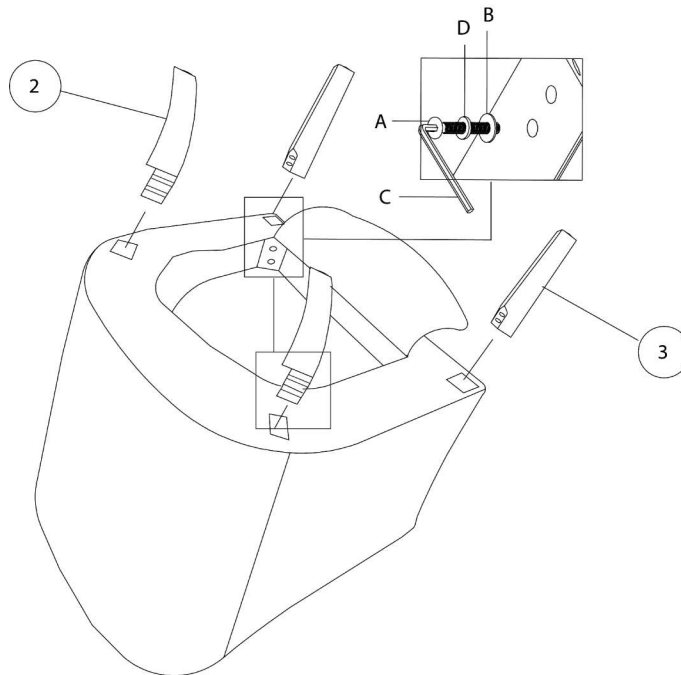

ÉTAPE / STEP 3

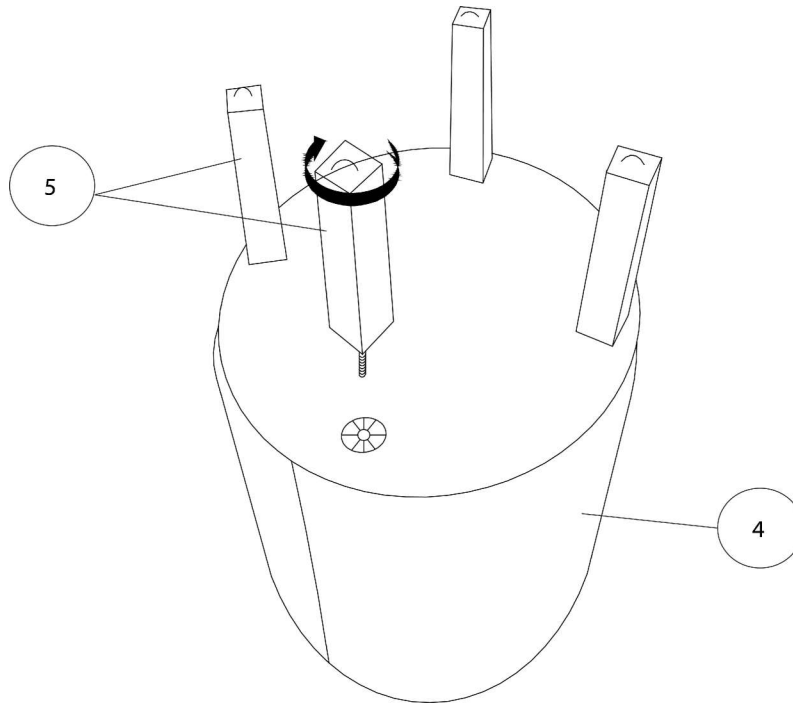

ÉTAPE / STEP 4

