



Specifications

**VSF 110DMH-SG6 SERIES**

Super Quiet Slim Fit Bathroom Fan with Humidity and Motion Sensor

**Description:** Super quiet DC (Direct Current) bathroom fan with adjustable speed control (80-140 CFM) engineered for continuous run • Integrated user adjustable motion and humidity sensors • Ceiling or wall mount • Suitable for new construction or remodeling • HVI certified • ENERGY STAR qualified • ETL listed for use in insulated ceilings (Type I.C.).

**Motor/Blower:** Permanently lubricated enclosed brushless DC motor engineered for continuous energy efficient operation; power rating 120v/60Hz; motor equipped with thermal shut off.

**Housing:** Rugged 26 GA galvanized steel; detachable 4" and 6" duct connector with built-in back draft dampener; 2 anti-vibration hangar bar brackets adjustable to 24" span included.

**Grille:** Low maintenance, wipe clean UV inhibiting polymeric resin; attaches to housing with torsion springs.

**Finishes:** White (W); Satin Nickel (SN); Oil Rubbed Bronze (OR).

**User Adjustable Integrated Sensors:** Motion sensor adjustable from 5 to 60 minutes; humidity sensor adjustable from 50-100% relative humidity (RH); either sensor starts fan.

**Warranty:** 6 Years

**Architect's Specifications:** Ventilation fan will be ceiling or wall mount, ENERGY STAR qualified, adjustable speed of 80-140 CFM and no more than 0.6 sones at 110 CFM as certified by HVI at 0.1 Ps (inches water gauge). Power consumption shall be no greater than 11 watts and ENERGY STAR rated with efficiency rating of no less than 10 CFM/watt. The motor will be enclosed brushless DC motor, engineered for continuous operation. Duct diameter will be 4" or 6" round. CFM switch tab will allow for 5 separate airflow (CFM) settings for 4" or 6" duct. Fan will begin operation when either someone enters room or humidity rises above user adjustable setpoint (50-100% RH). Dual motion and humidity sensors with adjustable timer that can be set from 5 to 60 minutes. Fan shall be ETL/cETL listed for tub/shower enclosure when used with GFCI branch circuit wiring and shall be ETL/cETL listed for use in insulated ceiling (Type I.C.). Fan shall be ASHRAE 62.2, LEED, CalGreen, and WA Ventilation Code compliant.

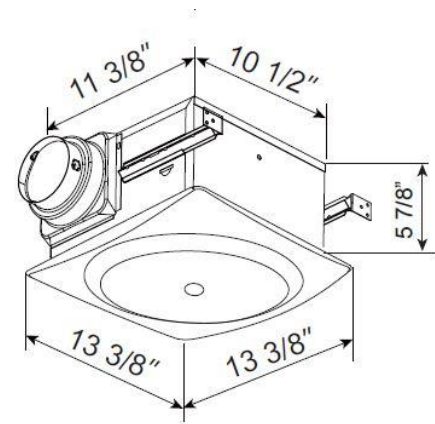

ETL Listed for installation over tub/shower enclosure with GFCI circuit wiring.



Model: VSF 110DMH-S G6 Series	6" Duct	
Static Pressure (inches w.g.)	0.1	0.25
Air Volume (CFM)	110	79
Noise (sones)	0.6	n/a
Power Consumption (Watts)	11	11
Energy Efficiency (CFM/Watts)	10	7.2
Current (AMPS)	0.2	0.2
ENERGY STAR rated	Yes	
Grille Dimensions	13 3/8" x 13 3/8"	



Model	Qty	Comments	Project
			Location
			Architect
			Engineer
			Contractor
			Submitted by
			Date