

Thank you for purchasing a DVI Lighting Product, we hope that it's timeless style and grace will create an enjoyable environment for you in the years to come.

SCHOOLHOUSE

DVP7521, 7551 pendant

Here are a few things to note before you install your light.

1. Please save these instructions for the future.
2. To install this fixture you will need a Phillips head screwdriver
3. After you unpack your fixture, ensure that you have all of the parts necessary for the successful installation of this product. If something seems to be missing, first look through all of the packing material. We suggest that you keep all of the packaging until the light is properly installed.

WARNING: RISK OF FIRE AND ELECTRIC SHOCK. THIS PRODUCT IS TO BE INSTALLED BY A QUALIFIED ELECTRICIAN ONLY. WIRE IN ACCORDANCE WITH NATIONAL AND LOCAL ELECTRICAL CODES.

after you install your light

1. Make sure to note the maximum recommended wattage for your light fixture - **DO NOT EXCEED THE RECOMMENDED WATTAGE.** The sockets on these fixtures are rated to 150 Watts medium base bulbs.
2. To clean your Fixture, we recommend that you use a mild detergent, such as dish washing soap, and warm water to clean the glass and metal surfaces. Use a damp soft cloth to wipe off dust. **DO NOT USE** abrasive pads or cleaning materials.

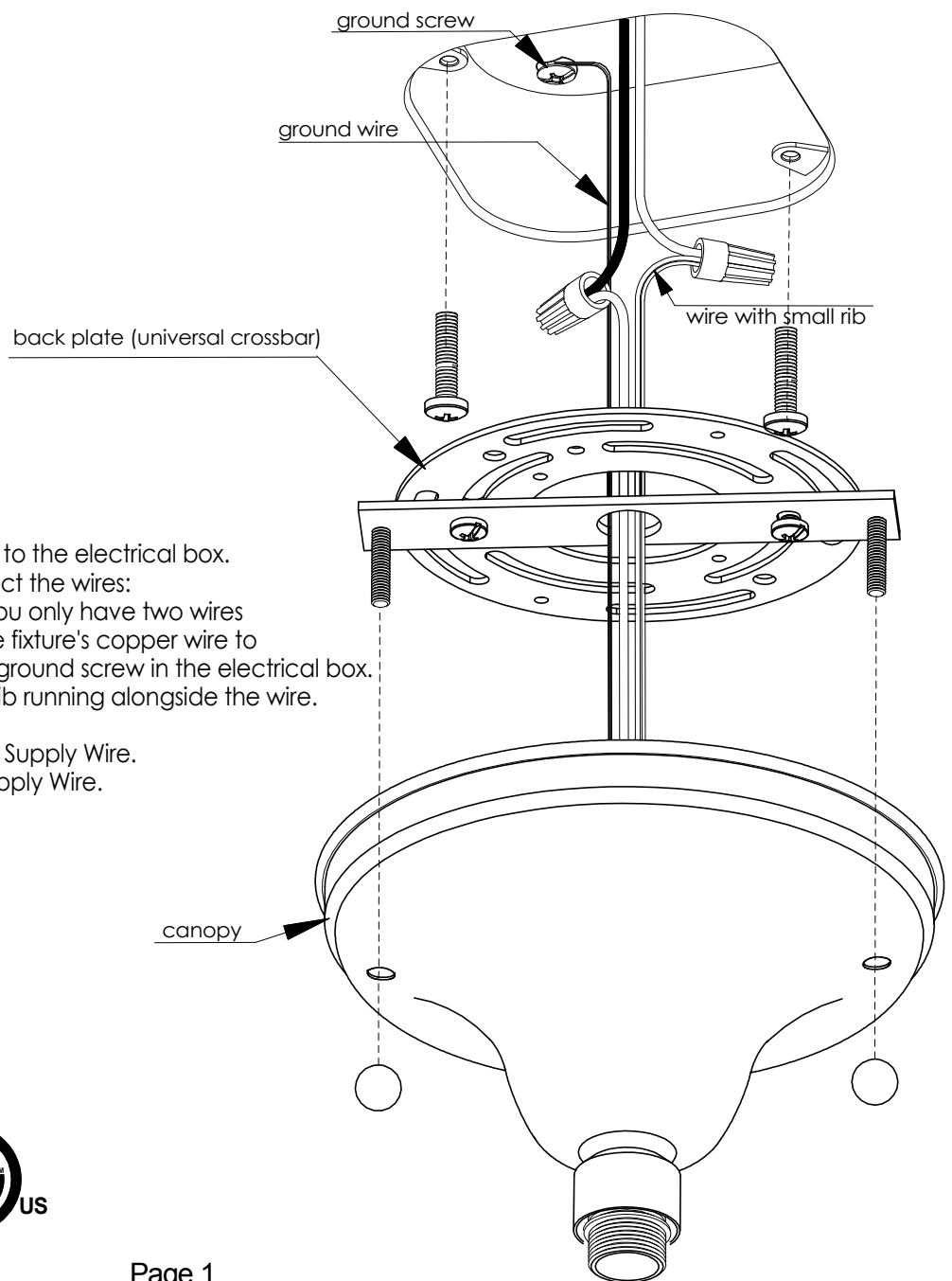

Electrical Assembly Instructions

1. Attach the back plate (universal crossbar) to the electrical box.
2. Using the supplied wire connectors, connect the wires:
A: Copper ground wire to Ground Wire - If you only have two wires coming from the electrical box, connect the fixture's copper wire to the Green ground screw on the crossbar or ground screw in the electrical box.
3. Note that one of the cord wires has small rib running alongside the wire. The wire with the rib is neutral wire.
B: Ribbed wire from fixture to White (neutral) Supply Wire.
C: Smooth wire from fixture to Black (hot) Supply Wire.

DVI
LIGHTING INC
WWW.DVICANADA.COM
120 Great Gulf Drive, Concord,
Ontario, Canada, L4K 5W1
Tel: (905) 660 5600
Fax: (905) 660 5700

5YR
warranty
Garantie de 5 ans

INTERTEK
ETL
LISTED US

SCHOOLHOUSE

DVP7521, 7551, pendant

Assembly Instructions:

1. Determine the intended height of the fixture and use the appropriate sizes of extension pipes. Attach pipes to the glass holder and on the other end to the ceiling canopy swivel.
2. Attach the universal crossbar of the fixture to the electrical box.
3. Place the fixture ceiling canopy over the screws, and attach the finials to hold the fixture in place.
4. Insert the bulb, use medium base bulb Max. 150Watts
5. Attach the glass with 3 thumb screws.

