

Pleasant Hearth[®]

KILLIAN FIRE PIT

MODEL #OFW307R

Español p. 9

Français p. 17

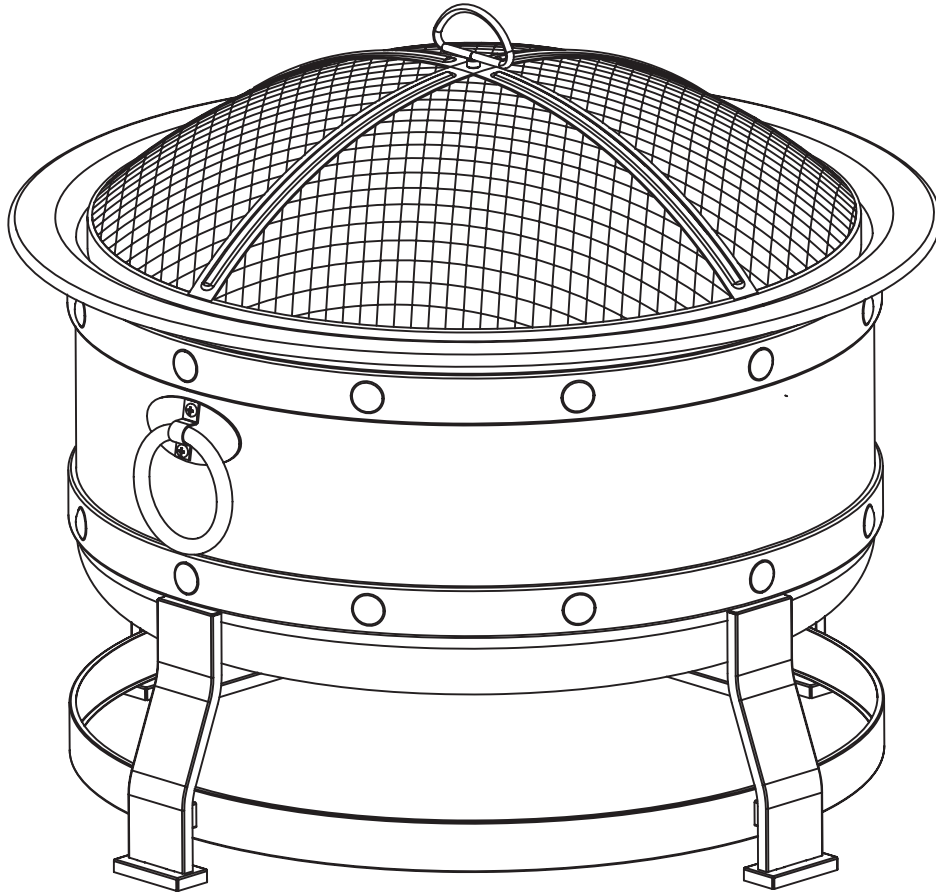

ATTACH YOUR RECEIPT HERE

Serial Number _____ Purchase Date _____



Questions, problems, missing parts? Before returning to your retailer, call our customer service department at 1-877-447-4768, 8:30 a.m. – 4:30 p.m. CST, Monday – Friday, or e-mail us at customerservice@ghpgroupinc.com

PACKAGE CONTENTS FOR OFW307R

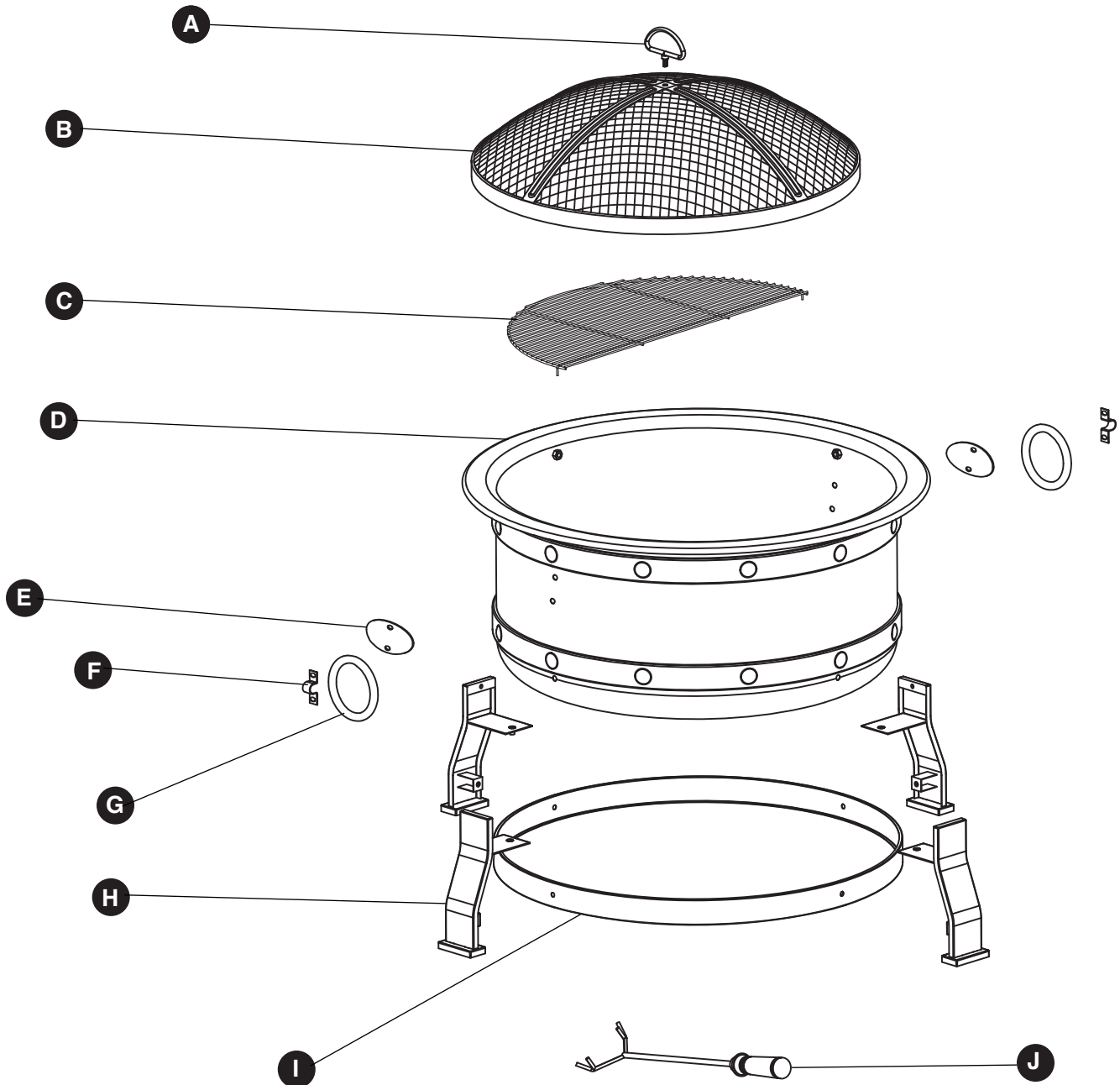

PART	DESCRIPTION	QTY
A	Poker Bracket	1
B	Mesh Cover	1
C	Cooking Grid	1
D	Fire Bowl	1
E	Ring Bracket Pad	2
F	Ring Bracket	2
G	Decorative Ring	2
H	Legs	4
I	Leg Support Ring	1
J	Poker	1

HARDWARE LIST

AA



M6x10mm
Bolt
Qty. 16

BB



M6 Nut
Qty. 5

CC

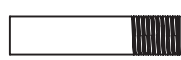

Threaded Peg
Qty. 4

DD



Wrench
Qty. 1

SAFETY INFORMATION

Please read and understand this entire manual before attempting to assemble, operate or install the product. If you have any questions regarding the product, please call customer service at 1-877-447-4768, 8:30 a.m. – 4:30 p.m. CST, Monday – Friday.

WARNINGS:

- **DO NOT** allow children or pets near the fire pit without supervision.
- **DO NOT** touch surface of fire pit while in use.
- **FOR OUTDOOR USE ONLY!** Burning wood and charcoal indoors can kill you. It gives off carbon monoxide, which has no odor.
- **NEVER** burn in vehicles, tents, garages, other enclosed areas or indoors. **CARBON MONOXIDE HAZARD.**
- **NEVER LEAVE FIRE UNATTENDED!**
- **NEVER** place a storage cover on fire pit when in use. Ensure the fire pit has cooled before placing a storage cover over the fire pit.
- When the fire pit is in use, the poker bracket on the mesh cover can reach extreme temperatures that can cause serious injury to an unprotected hand. Use a poker when handling.
- **DO NOT** use under overhead cables or power lines.

CAUTIONS:

- Adequate fire extinguishing material should be readily available.
- Always ensure that the mesh cover is secured over fire bowl while in use.
- Burn only seasoned hard wood or fire logs in the fire pit.
- **DO NOT** attempt to move the fire pit while it is hot or in use.
- **DO NOT** use gasoline or kerosene to start the fire in your fire pit.
- **DO NOT** use this outdoor fire pit under any overhead or near any unprotected combustible constructions. Avoid using near or under overhanging trees and shrubs. **DO NOT** use this unit on long or dry grass and/or leaves.
- Always use this outdoor fire pit on a hard, level, non-combustible surface such as concrete, rock or stone. An asphalt or blacktop surface may not be acceptable for this purpose. **DO NOT** use on wooden decks.
- Place the fire pit no closer than 10 feet / 3.05 meters from walls or combustibles during use.
- Poker handle may become hot during and after use.
- Use heat-resistant gloves to handle hot tools.

WARNING

This product and the fuels used to operate this product (charcoal or wood), and the products of combustion of such fuels, can expose you to chemicals including carbon black, which is known to the State of California to cause cancer, and carbon monoxide, which is known to the State of California to cause birth defects or other reproductive harm.

For more information go to www.p65Warnings.ca.gov

PREPARATION

Before beginning assembly of product, make sure all parts are present. Compare parts with package contents list and hardware contents above. If any part is missing or damaged, do not attempt to assemble the product. Contact customer service for replacement parts.

Estimated Assembly Time: 25 minutes

Tools Required for Assembly: Phillips Screwdriver (Not Included). Wrench (included).

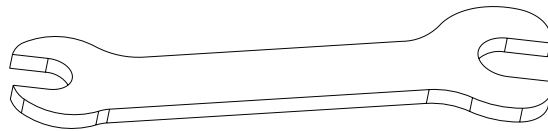
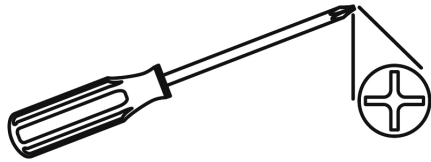

ASSEMBLY INSTRUCTIONS

1. To attach the decorative rings (G), insert two M6 x 10mm bolts (AA) through the ring bracket (F), over the decorative ring (G) and through the holes in the ring bracket pad (E). Then insert the same bolts through the pre-drilled holes in the fire bowl (D) as illustrated in figure 1. Tighten with two M6 nuts (BB) using the wrench and a Phillips screwdriver. Repeat this step for the other decorative ring (G) on the other side of the fire bowl.

Hardware Used

AA M6x10mm Bolt  x 4

BB M6 Nut  x 4

DD Wrench 

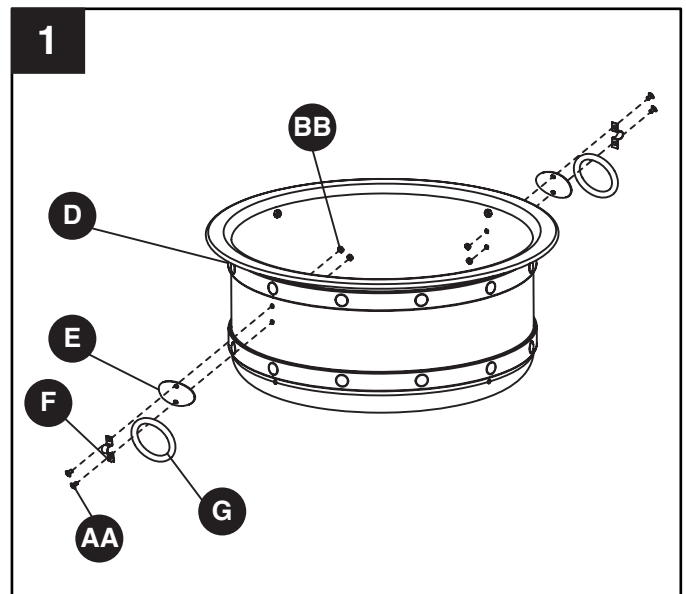

ASSEMBLY INSTRUCTIONS

2. Insert eight M6 x 10mm bolts (AA) through the holes in the firebowl (D) and into the rivet nut in the legs (H). Use a Phillips screwdriver to loosely tighten the M6x10mm bolts (AA), but do not fully tighten at this time.

Hardware Used

AA M6x10mm Bolt  x 8

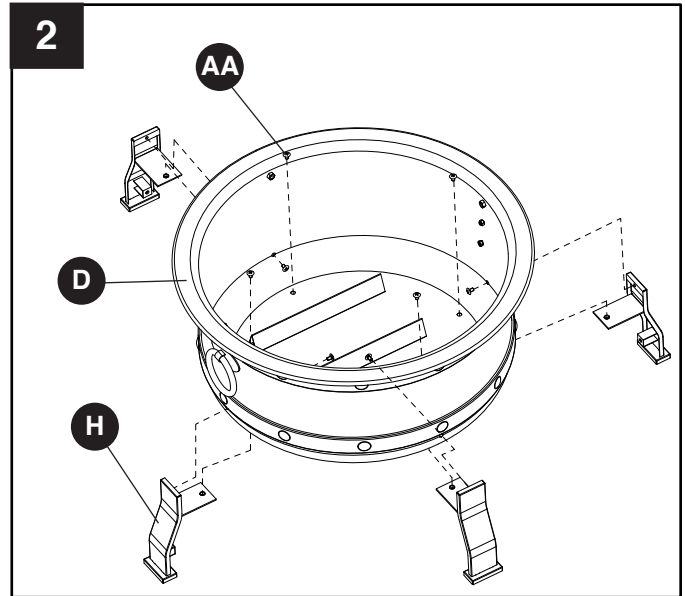

3. Attach the leg support ring (I) to the legs (H) by inserting four M6 x 10mm bolts (AA) through the holes in the support ring and into the rivet nuts in the legs. Tighten all bolts including those from the previous step with a Phillips screwdriver.

Hardware Used

AA M6x10mm Bolt  x 4

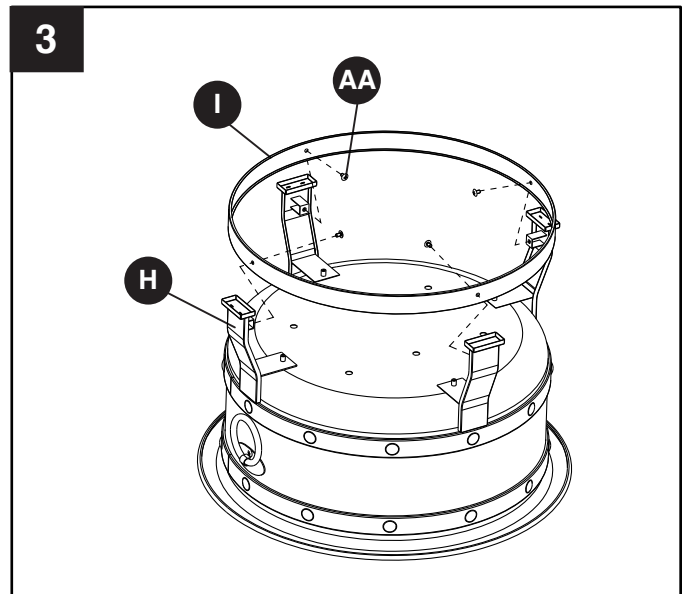

4. Finger tighten four threaded pegs (CC) to the inside of the fire bowl (D) as illustrated in figure 4.

Hardware Used

CC Threaded Pegs  x 4

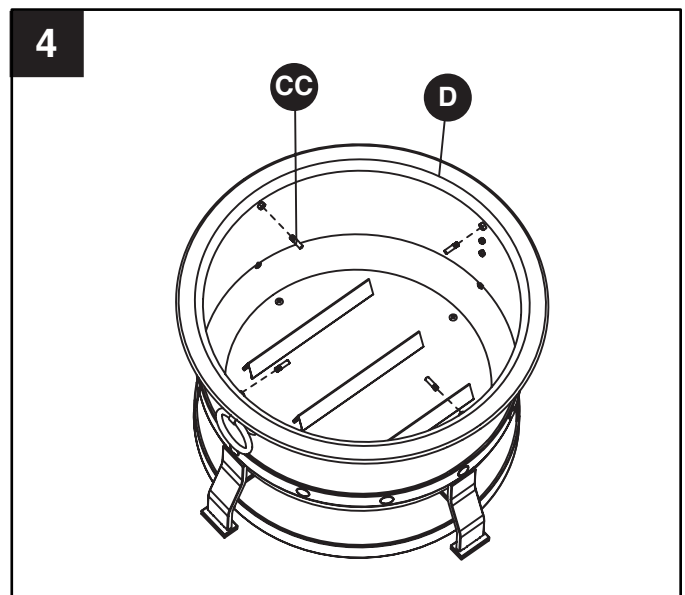

ASSEMBLY INSTRUCTIONS

5. Insert the poker bracket (A) into the hole in the mesh cover (B) using one M6 nut (BB). Tighten with the wrench (DD).

Hardware Used

BB M6 Nut  x 1

DD Wrench 

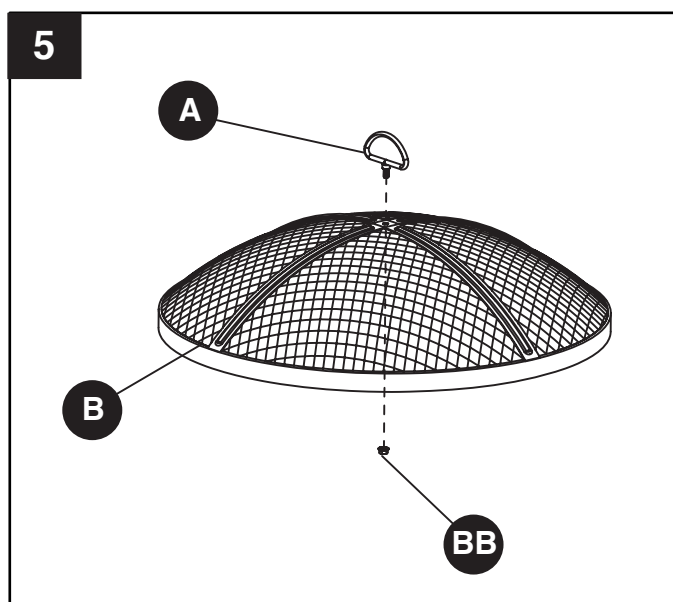

- 6.1 To use the fire pit, place the mesh cover (B) over the fire bowl as shown in figure 6-1.

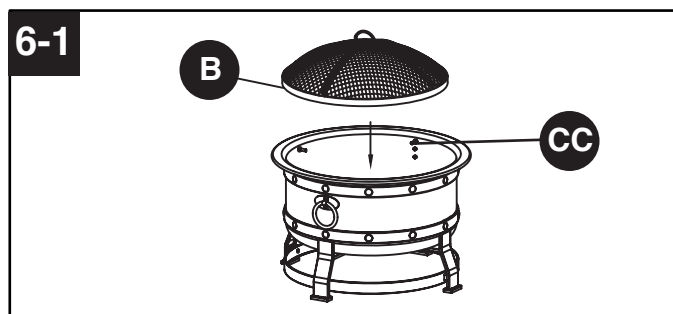

- 6.2 To use the fire pit as a barbeque, place the cooking grid (C) on the threaded pegs (CC) as shown in figure 6-2. Top with the mesh cover (B).

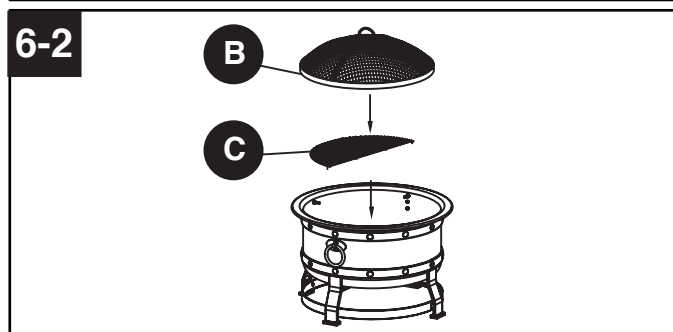

7. Your fire pit is now ready for use. Place the poker (J) near the fire pit for use as needed.

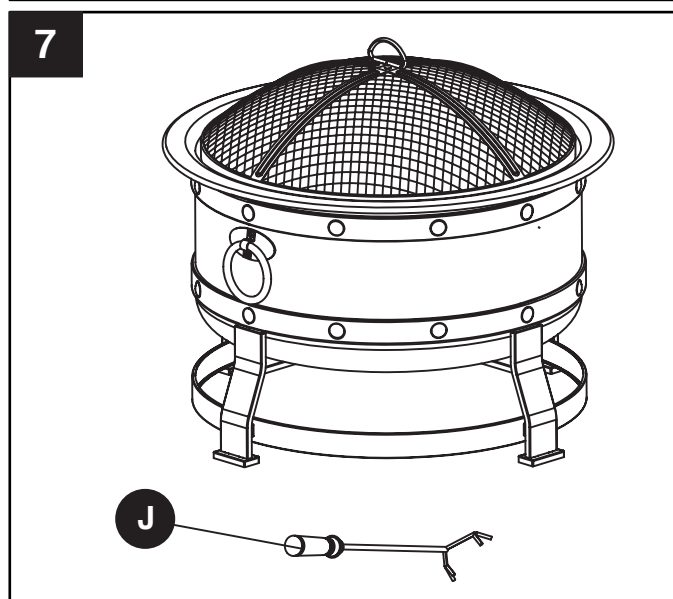

CARE AND MAINTENANCE

- Allow the fire pit to cool completely before moving the fire pit.
- To extend the life of your fire pit, clean it after each use.
- To protect fire pit finish, use a soft cloth to wipe fire pit and poker.
- Do not attempt to clean while hot.
- Store in a cool, clean, dry place.
- Clean fire bowl after each use once ashes have cooled.
- Place a storage cover over the fire pit once it has cooled.

ONE YEAR LIMITED FRAME WARRANTY

If within one year from the date of original purchase, this item fails due to a defect in material or workmanship, we will replace or repair at our option, free of charge. To order parts or to obtain warranty service, call 1-877-447-4768, 8:30AM – 4:30PM, CST, Monday – Friday. This warranty does not cover defects resulting from improper or abnormal use, misuse, accident, or alteration. Failure to follow all instructions in the owner's manual will also void this warranty. The manufacturer will not be liable for incidental or consequential damages, or common erosion of outdoor products. Some states do not allow the exclusion or limitation of incidental or consequential damages, so the above limitation may not apply to you. This warranty gives you specific legal rights, and you may also have other rights which vary from state to state.



GHP Group, Inc.
6440 W. Howard St.
Niles, IL 60714-3302
877-447-4768

REPLACEMENT PARTS LIST

For replacement parts, call our customer service department at 1-877-447-4768, 8:30 a.m. – 4:30 p.m., CST, Monday – Friday.

PART	DESCRIPTION	PART #
A	Poker Bracket	40-07-453
B	Mesh Cover	30-01-147
C	Cooking Grid	30-01-247
D	Fire Bowl	30-01-248
E	Ring Bracket Pad	30-01-249
F	Ring Bracket	30-01-194
G	Decorative Ring	30-01-195
H	Legs	30-01-250
I	Leg Support Ring	30-01-251
J	Poker	40-04-409
AA-DD	Hardware Pack	30-09-542
N/A	Instruction Manual	30-01-166

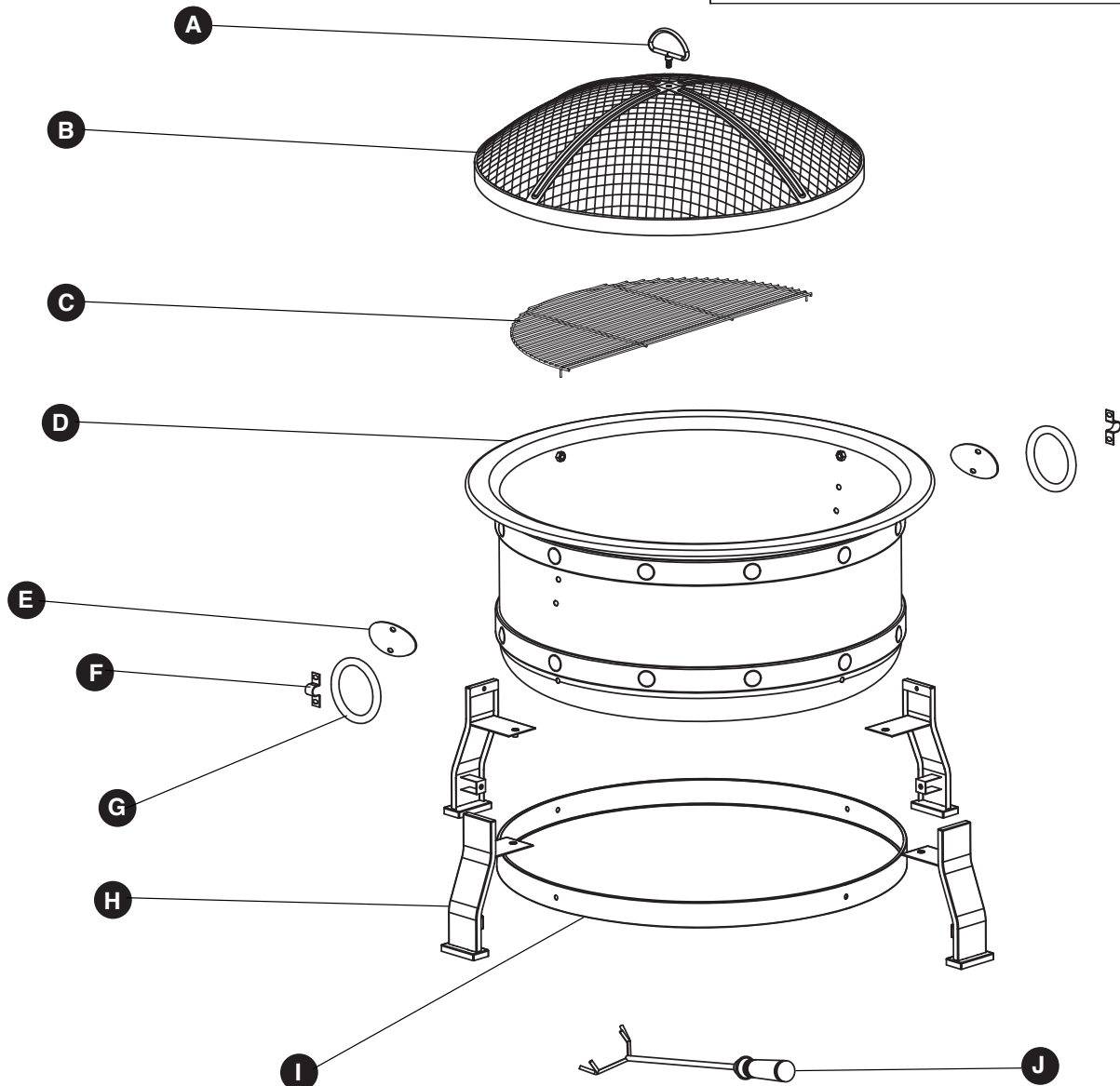
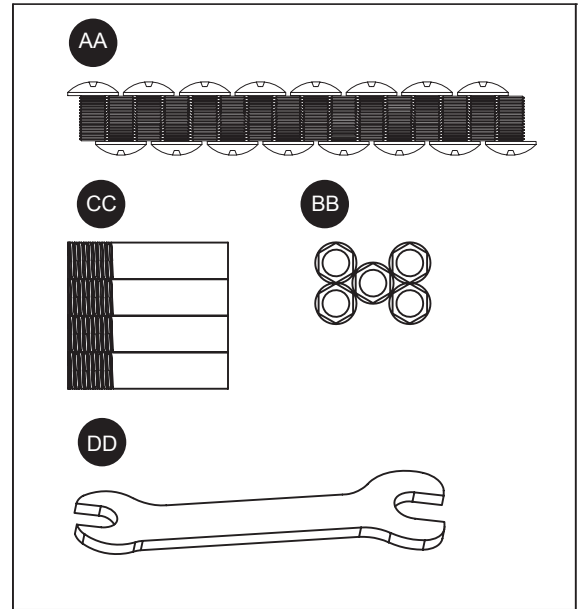

Pleasant Hearth®

BRASERO KILLIAN

MODELO N.º OFW307R

English p. 1

Français p. 17

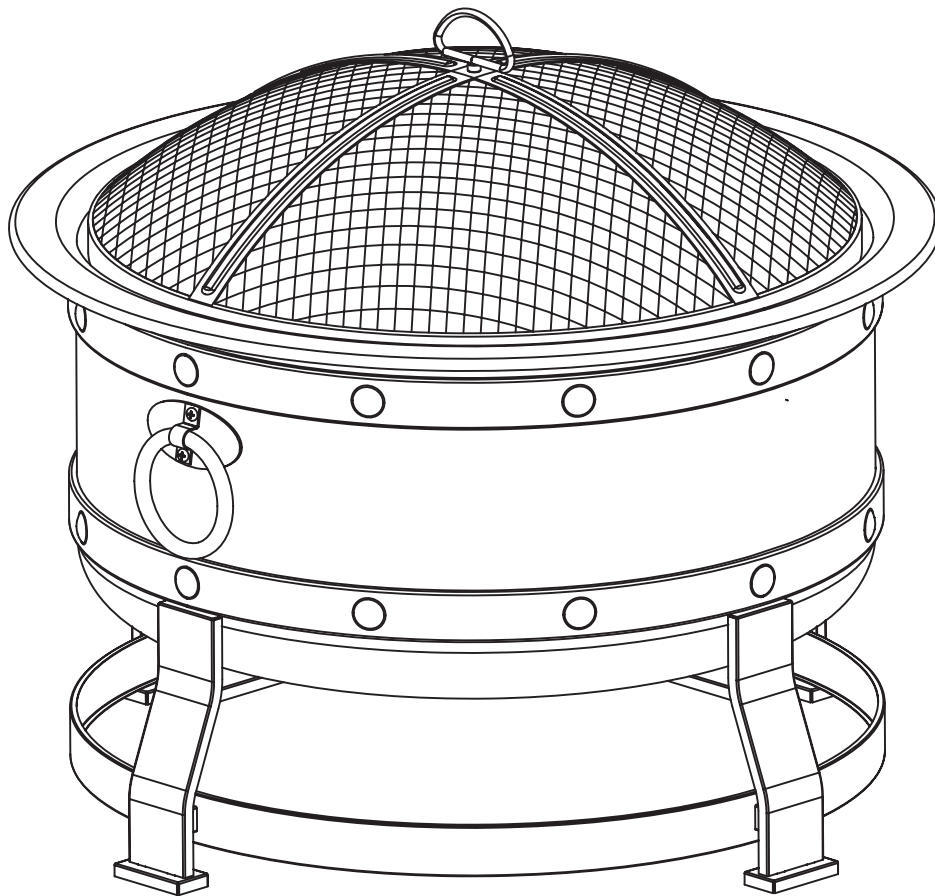

ADJUNTE AQUÍ SU RECIBO

Número de serie _____ Fecha de compra _____



¿Preguntas, problemas, piezas faltantes? Antes de hacer una devolución a la tienda, llame a nuestro Departamento de Atención al Cliente al 1-877-447-4768, de lunes a viernes de 8:30 a. m. a 4:30 p. m. hora central estándar, o escriba a customerservice@ghpgroupinc.com.

CONTENIDO DEL EMBALAJE DE OFW307R

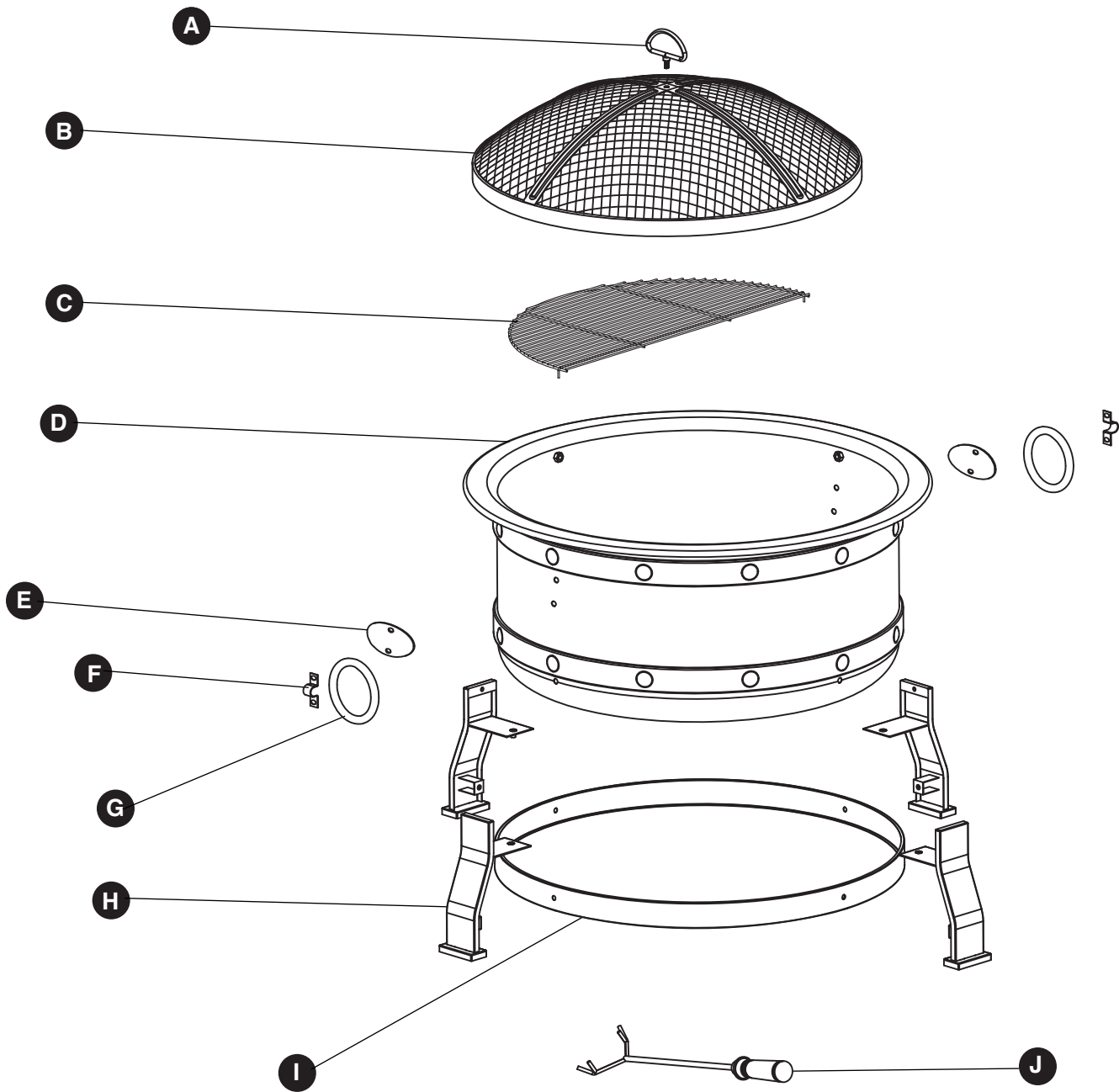

PIEZA	DESCRIPCIÓN	CANT.
A	Soporte para el atizador	1
B	Cubierta de malla	1
C	Parrilla de cocción	1
D	Contenedor de brasas	1
E	Ring Bracket Pad	2
F	Ring Bracket	2
G	Decorative Ring	2
H	Patas	4
I	Leg Support Ring	1
J	Atizador	1

LISTA DE HERRAMIENTAS Y TORNILLERÍA

AA



M6x10mm
Perno
Cant. 16

BB



M6 Tuerca
Cant. 5

CC

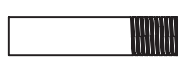

Clavija enroscada
Cant. 4

DD



Llave
Cant. 1

! INFORMACIÓN DE SEGURIDAD

Lea el manual entero atentamente antes de intentar ensamblar, poner en funcionamiento o instalar el producto. Si tiene preguntas relacionadas con el producto, llame al Departamento de Atención al Cliente al 1-877-447-4768, de lunes a viernes de 8:30 a. m. a 4:30 p. m. (hora central estándar).

! ADVERTENCIAS:

- **NO** deje que los niños o las mascotas se acerquen al brasero sin supervisión.
- **NO** toque la superficie del brasero durante su uso.
- **PARA UTILIZAR SOLO AL AIRE LIBRE.** Quemar madera y carbón en un espacio cerrado puede provocar la muerte. Produce monóxido de carbono, que es un gas inodoro.
- **NUNCA** encienda esta unidad en vehículos, carpas, garajes ni lugares cerrados. **PELIGRO DE EMISIÓN DE MONÓXIDO DE CARBONO.**
- **¡NUNCA DEJE EL FUEGO DESATENDIDO!**
- **NUNCA** coloque una funda sobre el brasero encendido. Asegúrese de que el brasero se haya enfriado antes de colocar la funda.
- Cuando el brasero esté en uso, el soporte para el atizador de la cubierta de malla puede alcanzar altas temperaturas, que podrían ocasionar lesiones graves si las manos no están protegidas. Utilice un atizador al manipular la unidad.
- **NO** utilice el brasero debajo de líneas de energía o cables aéreos.

! PRECAUCIONES:

- Debe tener a mano materiales adecuados para extinguir incendios.
- Asegúrese siempre de que la cubierta de malla esté bien sujeta sobre el contenedor de brasas mientras el unidad esté en uso.
- Queme en el brasero solo madera dura estacionada o leña.
- **NO** intente mover el brasero cuando esté caliente o en uso.
- **NO** utilice gasolina ni kerosene para encender el fuego en el brasero.
- **NO** utilice este brasero de exterior debajo de techos ni cerca de estructuras combustibles que no tengan protección. No lo use cerca o debajo de árboles o arbustos con ramas colgantes.
- **NO** use la unidad en lugares donde haya hojas o césped alto que estén secos.
- Siempre utilice este brasero de exterior sobre una superficie dura, nivelada y no combustible, como cemento, roca o piedra. Algunas superficies asfaltadas o pavimentadas no son aceptables para tal fin. **NO** utilice el brasero sobre pisos de madera.
- Ubique el brasero a una distancia mínima de 10 pies (3,05 metros) respecto de las paredes o elementos combustibles durante su uso.
- El mango del atizador puede calentarse durante y después del uso.
- Utilice guantes resistentes al calor para manipular herramientas calientes.

! ADVERTENCIA

Este producto y los combustibles utilizados para poner en funcionamiento este producto (carbon o madera) y los productos de la combustión de tales combustibles, pueden exponerlo a sustancias químicas como el negro de carbón, que según el estado de California, puede provocar cáncer, y el monóxido de carbono, que, según el estado de California, puede provocar anomalías congénitas u otros daños reproductivos.

Para obtener más información, visite www.p65Warnings.ca.gov

PREPARACIÓN

Antes de comenzar el ensamblaje de este producto, asegúrese de que estén todas las piezas. Compare las piezas con la lista de contenido del embalaje y el contenido de tornillería y herramientas de arriba. Si falta alguna pieza o está dañada, no intente ensamblar el producto. Comuníquese con el servicio de atención al cliente para solicitar piezas de repuesto.

Tiempo estimado de ensamblaje: 25 minutos

Herramientas requeridas para el ensamblaje: Destornillador Phillips (no incluido). Llave inglesa (incluida).

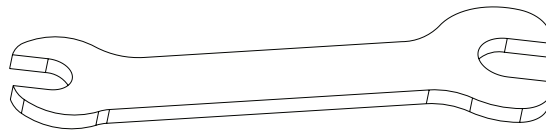
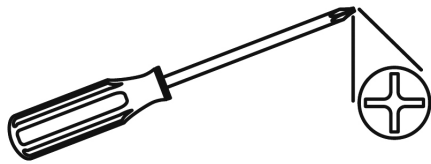

INSTRUCCIONES DE ENSAMBLAJE

1. To attach the decorative rings (G), insert two M6 x 10mm bolts (AA) through the ring bracket (F), to the decorative ring (G) over the ring bracket pad (E) and through the pre-drilled holes in the fire bowl (D) as illustrated in figure 1. Tighten with two M6 nuts (BB) using the wrench and a Phillips screwdriver. Repeat this step for the other decorative ring (G) on the other side of the fire bowl.

Herramientas y tornillería utilizadas

AA M6x10mm Perno  x 4

BB M6 Tuerca  x 4

DD Llave 

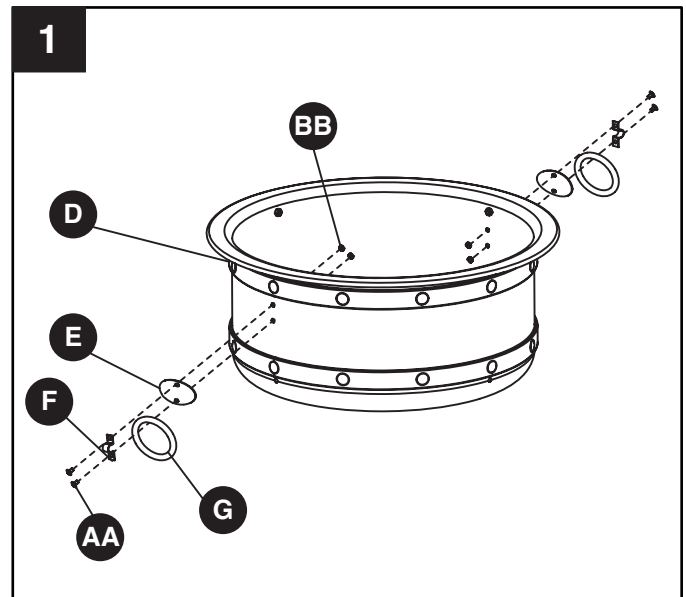

INSTRUCCIONES DE ENSAMBLAJE

2. Insert eight M6 x 10mm bolts (AA) through the holes in the firebowl (D) and into the pre-drilled nuts in the legs (H). Use a Phillips screwdriver to loosely tighten the M6x10mm bolts (AA), but do not fully tighten at this time.

Herramientas y tornillería utilizadas

AA M6x10mm Perno  x 8

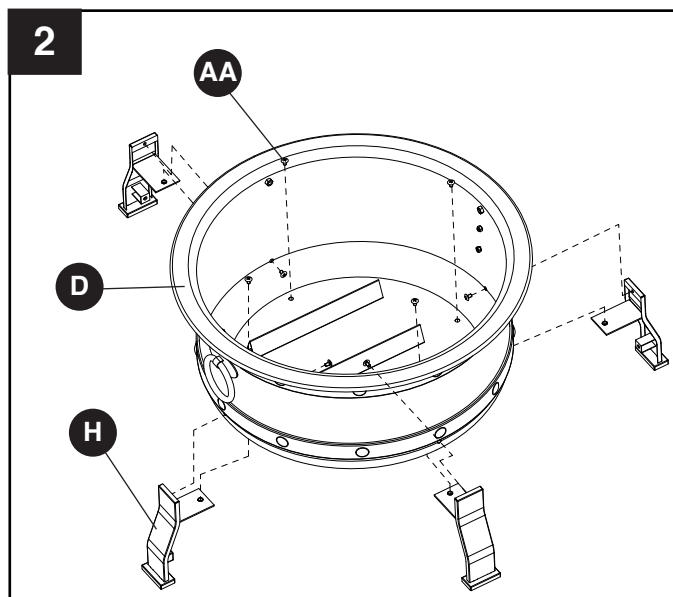

3. Attach the leg support ring (I) to the legs (H) by inserting four M6 x 10mm bolts (AA) through the holes in the support ring and into the pre-drilled nuts in the legs. Tighten with a Phillips screwdriver.

Herramientas y tornillería utilizadas

AA M6x10mm Perno  x 4

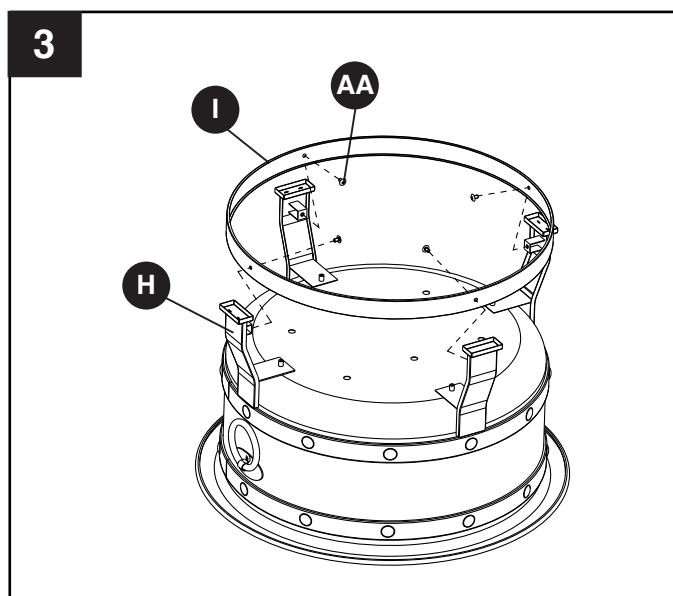

4. Finger tighten four threaded pegs (CC) to the inside of the fire bowl (D) as illustrated in figure 4.

Herramientas y tornillería utilizadas

CC Clavija enroscada  x 4

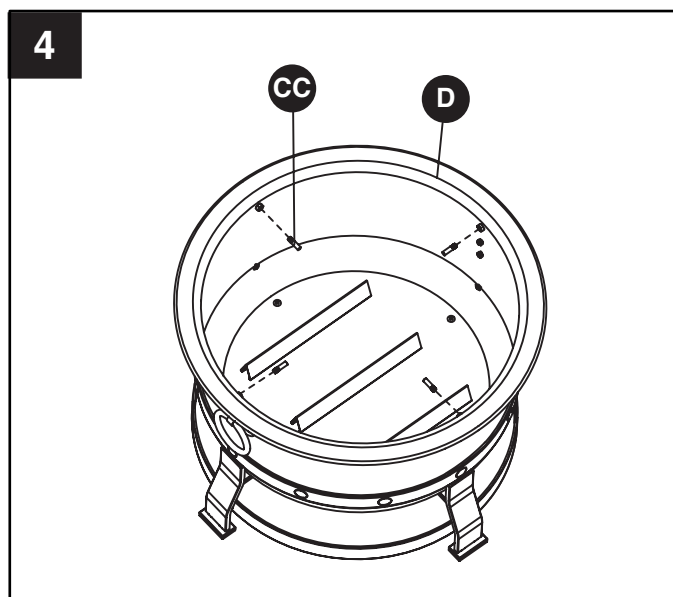

INSTRUCCIONES DE ENSAMBLAJE

5. Insert the poker bracket (A) into the hole in the mesh cover (B) using one M6 nut (BB). Finger tighten.

Herramientas y tornillería utilizadas

BB M6 Tuerca  x 1

- 6.1 To use the fire pit, place the mesh cover (B) over the fire bowl as shown in figure 6-1.

- 6.2 To use the fire pit as a barbeque, place the cooking grid (C) on the threaded pegs (CC) as shown in figure 6-2. Top with the mesh cover (B).

7. Your fire pit is now ready for use. Place the poker (J) near the fire pit for use as needed.

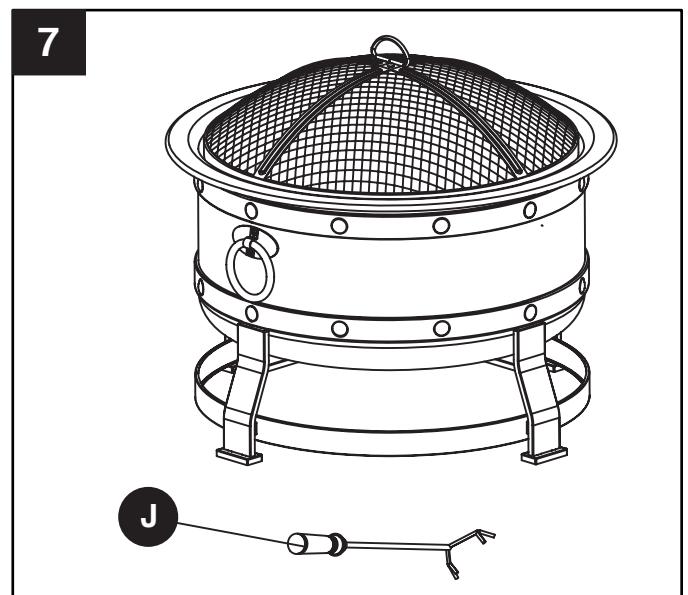
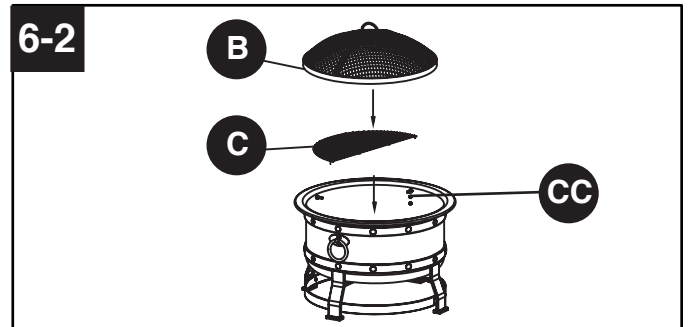
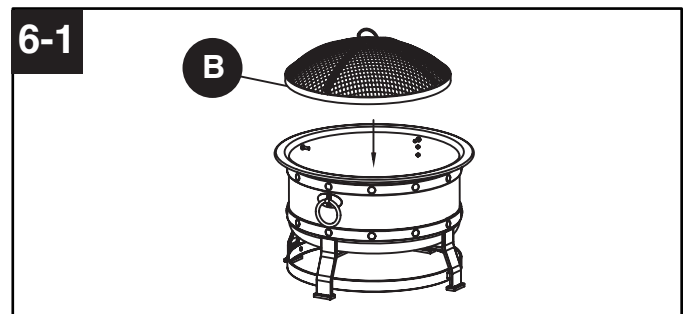
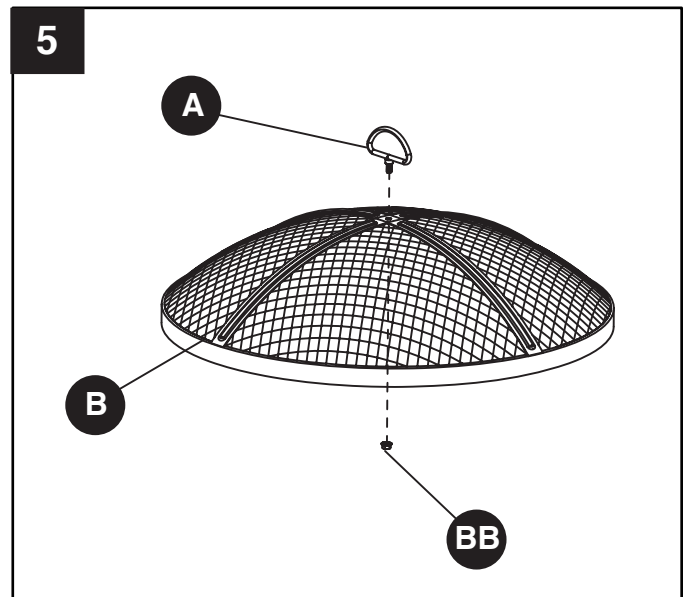

CUIDADO Y MANTENIMIENTO

- Deje que el brasero se enfríe completamente antes de moverlo.
- Para prolongar la vida útil del brasero, límpielo después de cada uso.
- Para proteger el acabado del brasero, limpie el brasero y el atizador con un paño suave.
- No intente limpiarlo cuando esté caliente.
- Guarde el artefacto en un lugar fresco, limpio y seco.
- Limpie el contenedor de brasas después de cada uso, una vez que las cenizas se hayan enfriado.
- Coloque la funda sobre el brasero una vez que se haya enfriado.

GARANTÍA LIMITADA DE UN AÑO PARA LA ESTRUCTURA

Si durante el transcurso de un año a partir de la fecha de compra original, este artículo no funciona correctamente debido a un defecto en el material o en la mano de obra, lo reemplazaremos o repararemos sin cargo, según nuestro criterio. Para solicitar piezas u obtener el servicio de la garantía, llame al 1-877-447-4768, de lunes a viernes de 8:30 a. m. a 4:30 p. m. (hora central estándar). Esta garantía no cubre defectos ocasionados por uso inapropiado o anormal, uso indebido, accidentes o alteraciones. Si no se respetan todas las instrucciones del manual del propietario, esta garantía quedará anulada. El fabricante no será responsable de daños incidentales o indirectos, ni del deterioro normal de los productos para exteriores. Algunos estados no permiten la exclusión o limitación de daños incidentales o indirectos. Por lo tanto, es posible que la limitación mencionada no se aplique en su caso. Esta garantía otorga derechos legales específicos, y podría haber otros derechos aplicables según el estado.



GHP Group, Inc.
6440 W. Howard St.
Niles, IL 60714-3302, EE. UU.
877-447-4768

LISTA DE PIEZAS DE REPUESTO

Para obtener las piezas de repuesto, llame a nuestro Departamento de Atención al Cliente al 1-877-447-4768, de lunes a viernes de 8:30 a. m. 4:30 p. m. (hora central estándar).

PIEZA	DESCRIPCIÓN	N.º DE PIEZA
A	Soporte para el atizador	40-07-453
B	Cubierta de malla	30-01-147
C	Parrilla de cocción	30-01-247
D	Contenedor de brasas	30-01-248
E	Ring Bracket Pad	30-01-249
F	Ring Bracket	30-01-194
G	Decorative Ring	30-01-195
H	Patatas	30-01-250
I	Leg Support Ring	30-01-251
J	Atizador	40-04-409
AA-DD	Paquete de tornillería	30-09-542
N/A	Manual de Instrucciones	30-01-166

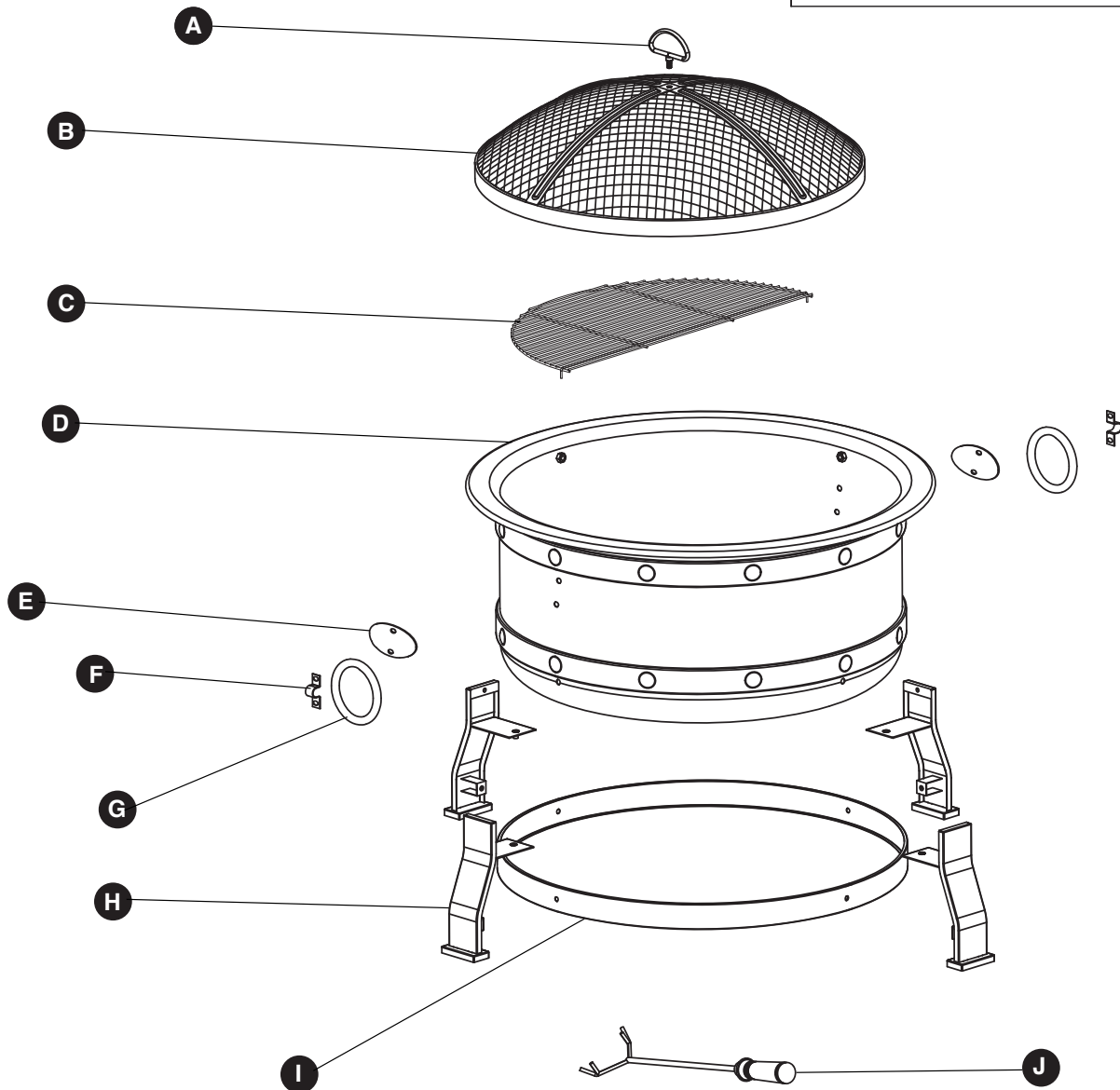
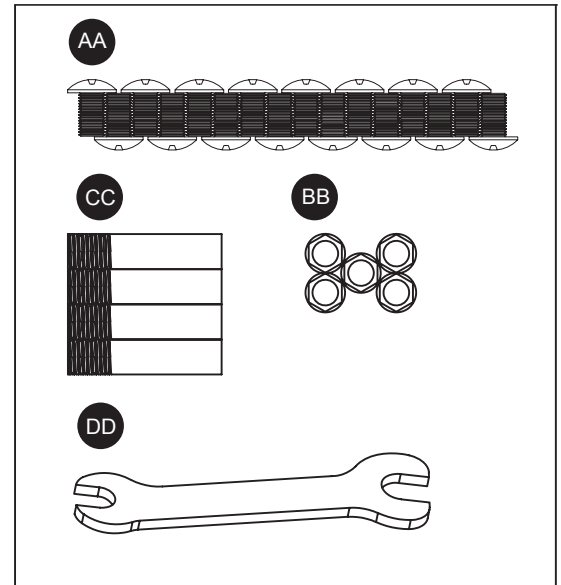

Pleasant Hearth®

FOYER EXTÉRIEUR KILLIAN

MODÈLE n° OFW307R

English p. 1

Español p. 9

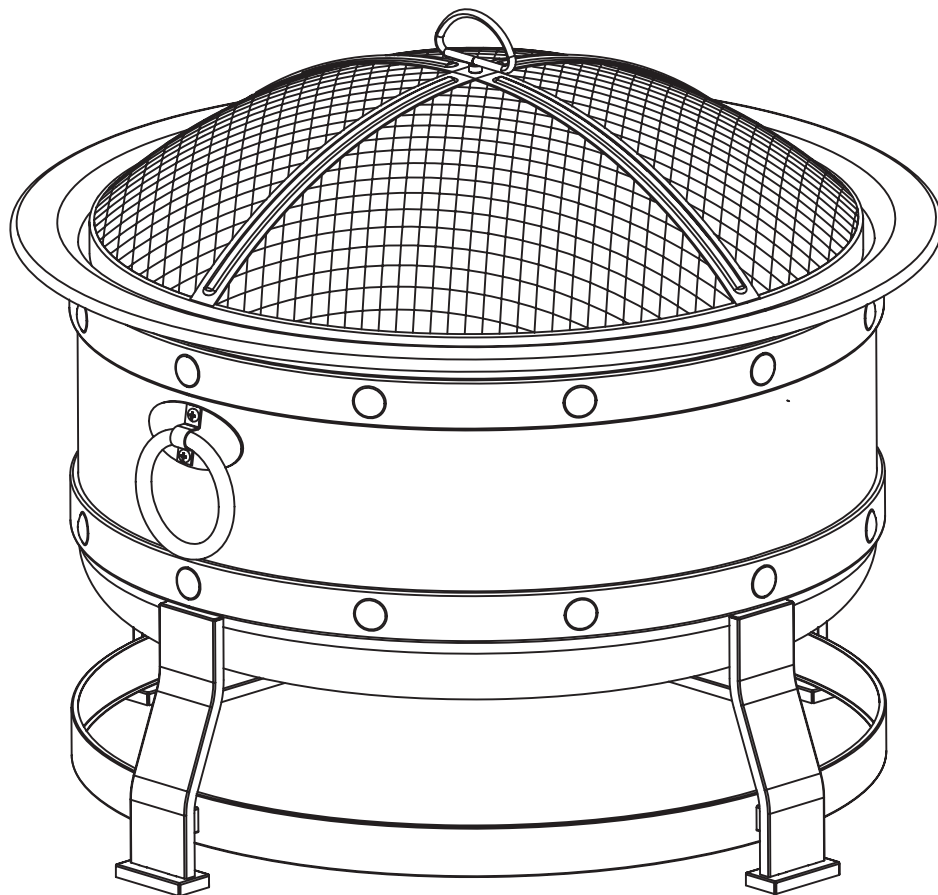

AGRAFEZ VOTRE FACTURE ICI

Numéro de série _____ Date d'achat _____



Questions, problèmes, pièces manquantes? Avant de retourner l'article au détaillant, appelez notre service à la clientèle au 1 877 447-4768, entre 8 h 30 et 16 h 30 (HNC), du lundi au vendredi, ou envoyez un courriel à customerservice@ghpgroupinc.com

CONTENU DE L'EMBALLAGE POUR OFW307R

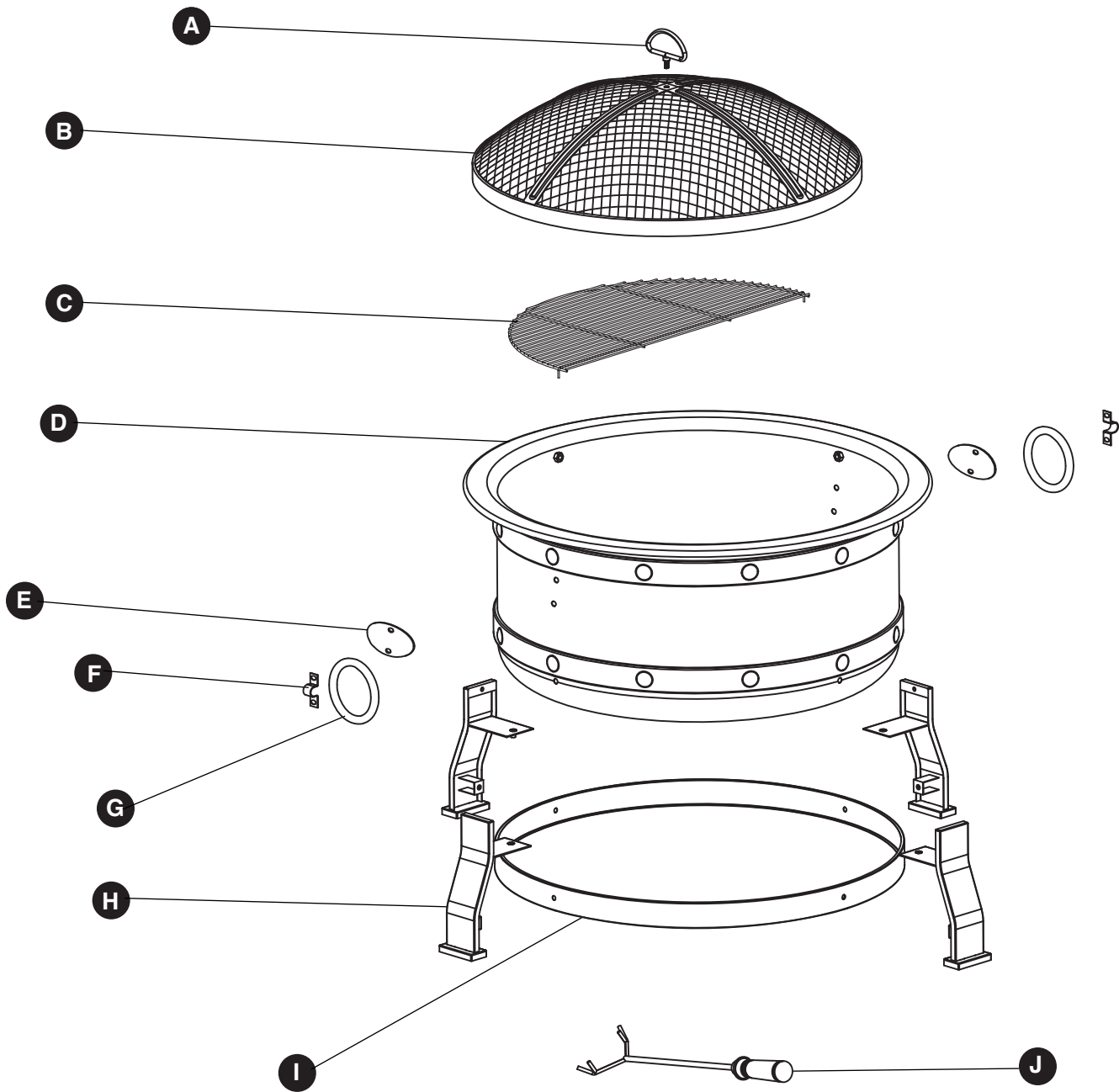

PIÈCE	DESCRIPTION	QTÉ
A	Anneau de soulèvement	1
B	Pare-étincelles en grillage	1
C	Grille de cuisson	1
D	Vasque de feu	1
E	Ring Bracket Pad	2
F	Ring Bracket	2
G	Decorative Ring	2
H	Pieds	4
I	Leg Support Ring	1
J	Tisonnier	1

LISTE DE MATÉRIEL

AA



M6x10mm
Boulon
Qté. 16

BB



M6 écrou
Qté. 5

CC



Patère filetée
Qté. 4

DD



Clé
Qté. 1

INFORMATIONS RELATIVES À LA SÉCURITÉ

Veillez lire et comprendre le présent guide au complet avant de tenter d'assembler, d'utiliser ou d'installer le produit. Si vous avez des questions concernant le produit, veuillez appeler le service à la clientèle au 1-877-447-4768, de 8 h 30 à 16 h 30 (HNC), du lundi au vendredi.

AVERTISSEMENTS :

- **NE laissez PAS** les enfants ou les animaux domestiques s'approcher du foyer extérieur sans surveillance.
- **NE touchez PAS** la surface du foyer extérieur lorsqu'il est allumé.
- **POUR UTILISATION EXTÉRIEURE UNIQUEMENT!** Brûler du bois ou du charbon à l'intérieur peut être mortel. La combustion dégage du monoxyde de carbone, qui n'a pas d'odeur.
- **N'utilisez JAMAIS** le produit à l'intérieur, soit dans un véhicule, une tente, un garage ou tout autre espace fermé. **RISQUE D'INTOXICATION AU MONOXYDE DE CARBONE.**
- **NE LAISSEZ JAMAIS UN FEU SANS SURVEILLANCE!**
- **NE placez JAMAIS** la housse de rangement sur le foyer extérieur lorsqu'il est allumé. Laissez refroidir le foyer extérieur avant de le recouvrir avec la housse de rangement.
- **NE placez PAS** le foyer sous des lignes aériennes ou des lignes électriques.

MISES EN GARDE :

- Du matériel d'extinction d'incendie adéquat doit être facilement accessible.
- Assurez-vous toujours que le pare-étincelles est bien installé au-dessus de la vasque de feu lorsque le foyer est allumé.
- Ne faites brûler que du bois ou des bûches régulières dans le foyer extérieur.
- **N'essayez PAS** de déplacer le foyer extérieur pendant qu'il est chaud ou allumé.
- **N'utilisez PAS** d'essence ni de kérosène pour allumer un feu dans le foyer extérieur.
- **N'utilisez PAS** le foyer extérieur sous une construction combustible non protégée ou près d'une telle construction. Évitez de l'utiliser sous des arbres et arbustes ou près de tels végétaux. **N'utilisez PAS** l'appareil sur de l'herbe sèche ou longue ou sur des feuilles.
- Utilisez toujours le foyer extérieur sur une surface dure, nivelée et non combustible faite, par exemple, de béton, de roche ou de pierre. Le foyer extérieur ne peut être utilisé sur une surface asphaltée ou un revêtement hydrocarburé. **N'utilisez PAS** l'appareil sur une terrasse en bois.
- Placez le foyer extérieur à 3,05 m (10 pi) et plus des murs et des matériaux combustibles lorsqu'il est allumé.
- La poignée du tisonnier peut devenir brûlante pendant l'utilisation et le demeurer après l'utilisation.
- Utilisez des gants résistants à la chaleur pour manipuler les outils brûlants.

AVERTISSEMENT

Ce produit et les combustibles utilisés pour le faire fonctionner (charbon ou bois), de même que les produits de leur combustion, peuvent vous exposer à des substances chimiques comme le noir de carbone, reconnu par l'État de la Californie comme causant le cancer, ou le monoxyde de carbone, reconnu par l'État de la Californie comme causant des anomalies congénitales ou d'autres problèmes de reproduction.

Pour plus de renseignements, visitez le www.p65Warnings.ca.gov

PRÉPARATION

Avant de commencer l'assemblage du foyer, assurez-vous d'avoir toutes les pièces. Comparez les pièces à la liste de contenu de l'emballage et de quincaillerie fournie précédemment. Si des pièces sont manquantes ou défectueuses, n'essayez pas d'assembler le produit. Veuillez communiquer avec le service à la clientèle afin d'obtenir des pièces de rechange.

Estimation du temps d'assemblage : 30 minutes

Outils nécessaires pour l'assemblage : Tournevis cruciforme (non compris). Clé (comprise).

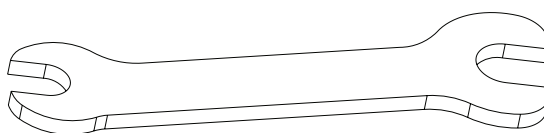
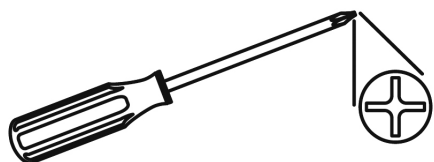

INSTRUCTIONS D'ASSEMBLAGE

1. To attach the decorative rings (G), insert two M6 x 10mm bolts (AA) through the ring bracket (F), to the decorative ring (G) over the ring bracket pad (E) and through the pre-drilled holes in the fire bowl (D) as illustrated in figure 1. Tighten with two M6 nuts (BB) using the wrench and a Phillips screwdriver. Repeat this step for the other decorative ring (G) on the other side of the fire bowl.

Quincaillerie utilisée

AA M6x10mm Boulon  x 4

BB M6 écrou  x 4

DD Clé 

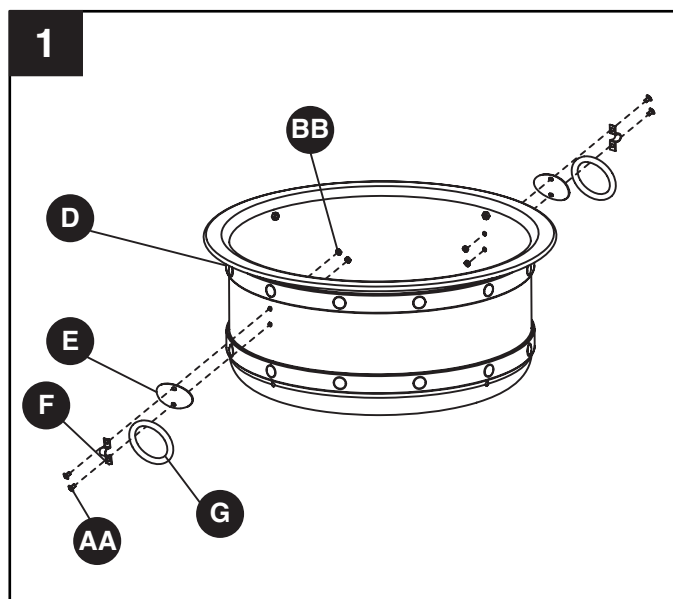

INSTRUCTIONS D'ASSEMBLAGE

2. Insert eight M6 x 10mm bolts (AA) through the holes in the firebowl (D) and into the pre-drilled nuts in the legs (H). Use a Phillips screwdriver to loosely tighten the M6x10mm bolts (AA), but do not fully tighten at this time.

Quincaillerie utilisée

AA M6x10mm Boulon  x 8

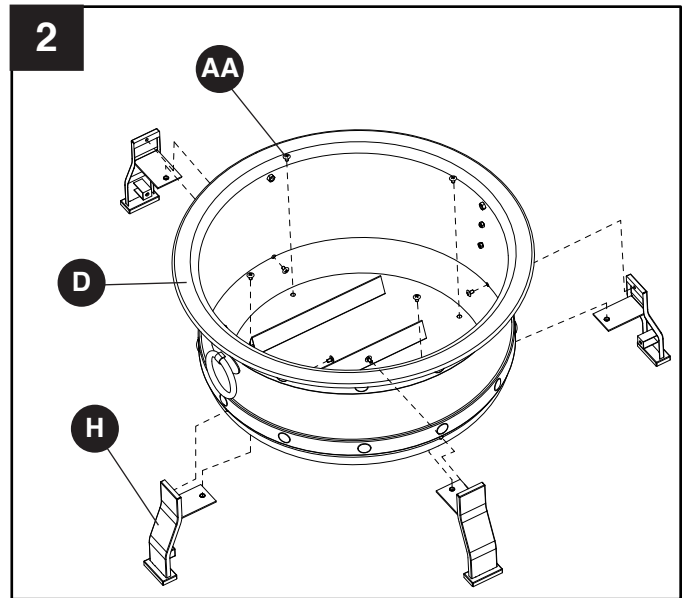

3. Attach the leg support ring (I) to the legs (H) by inserting four M6 x 10mm bolts (AA) through the holes in the support ring and into the pre-drilled nuts in the legs. Tighten with a Phillips screwdriver.

Quincaillerie utilisée

AA M6x10mm Boulon  x 4

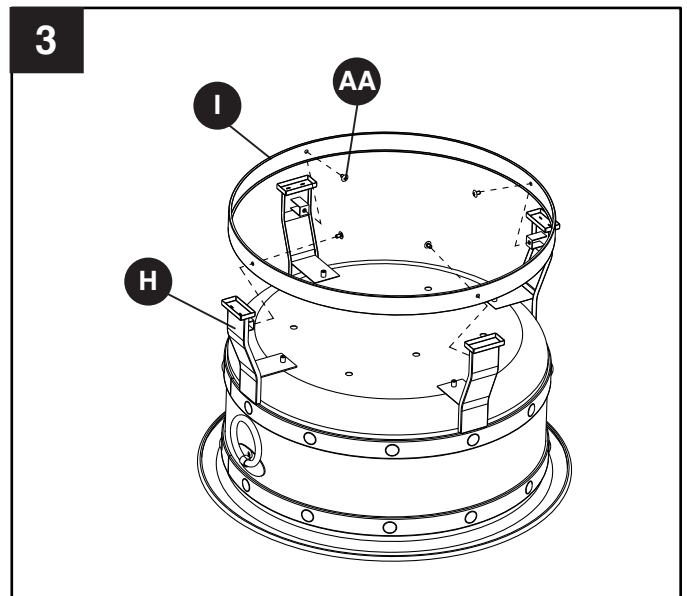

4. Finger tighten four threaded pegs (CC) to the inside of the fire bowl (D) as illustrated in figure 4.

Quincaillerie utilisée

CC Patère filetée  x 4

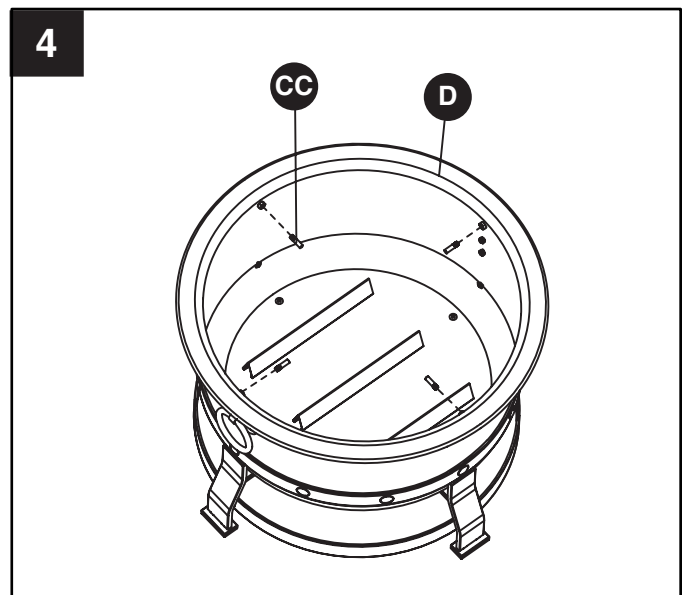

INSTRUCTIONS D'ASSEMBLAGE

5. Insert the poker bracket (A) into the hole in the mesh cover (B) using one M6 nut (BB). Finger tighten.

Herramientas y tornillería utilizadas

BB M6 écrou  x 1

- 6.1 To use the fire pit, place the mesh cover (B) over the fire bowl as shown in figure 6-1.

- 6.2 To use the fire pit as a barbeque, place the cooking grid (C) on the threaded pegs (CC) as shown in figure 6-2. Top with the mesh cover (B).

7. Your fire pit is now ready for use. Place the poker (J) near the fire pit for use as needed.

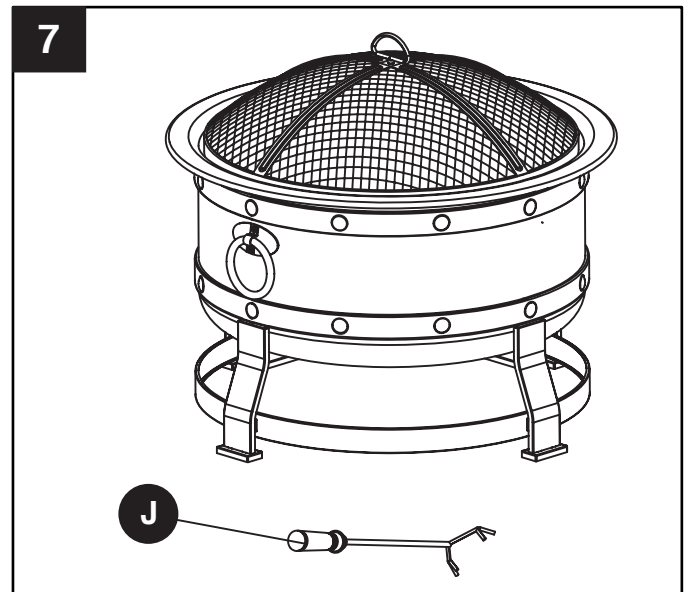
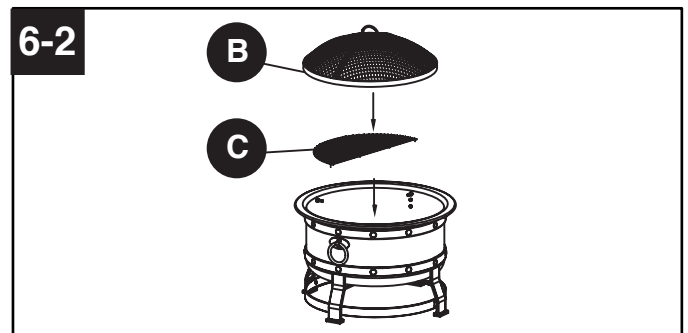
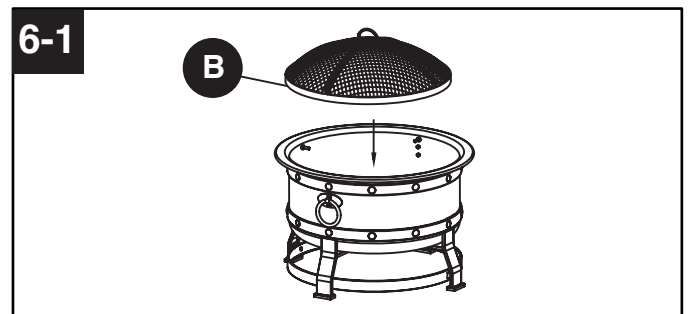
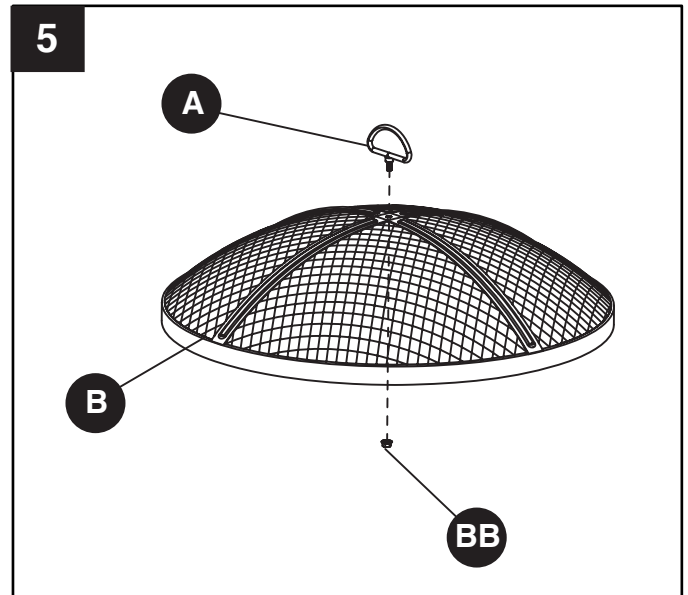

ENTRETIEN ET MAINTENANCE

- Laissez le foyer extérieur refroidir complètement avant de le déplacer.
- Pour prolonger la durée de vie de votre foyer extérieur, lavez-le après chaque utilisation.
- Pour protéger le fini, essuyez le foyer extérieur et le tisonnier à l'aide d'un chiffon doux.
- Ne tentez pas de nettoyer le foyer extérieur lorsqu'il est chaud.
- Entrez le foyer extérieur dans un endroit frais, propre et sec.
- Nettoyez la vasque de feu après chaque utilisation, une fois que les cendres ont refroidi.
- Une fois le foyer extérieur refroidi, couvrez-le à l'aide d'une housse de rangement.

1 AN DE GARANTIE LIMITÉE DE FRAME

Si, au cours d'une période d'un an à compter de la date originelle de l'achat, cet article s'avère défectueux en raison d'un défaut de matériau ou de fabrication, nous nous engageons à le remplacer ou à le réparer, à notre discrétion, sans frais. Pour commander des pièces ou pour obtenir un service sous garantie, appelez au 1 877 447-4768, entre 8 h 30 et 16 h 30 (HNC), du lundi au vendredi. La présente garantie ne couvre pas les défauts résultant d'une utilisation non conforme ou anormale, d'une mauvaise utilisation, d'un accident ou d'une modification. Omettre de suivre toutes les instructions contenues dans le présent guide annule aussi cette garantie. Le fabricant ne sera en aucun cas tenu responsable pour tout dommage consécutif ou indirect et pour toute érosion normale des produits d'extérieur. Les lois en vigueur dans certains États, provinces ou territoires n'autorisent pas l'exclusion ou la limitation des dommages consécutifs ou indirects et, par conséquent, la clause de limitation énoncée ci-dessus pourrait ne pas s'appliquer à vous. La présente garantie vous accorde des droits spécifiques reconnus par la loi et vous bénéficiez peut-être aussi d'autres droits, qui peuvent varier selon l'État, la province ou le territoire.



GHP Group, Inc.
6440 W. Howard St.
Niles, IL 60714-3302 États-Unis
1 877 447-4768

LISTE DES PIÈCES DE RECHANGE

Pour des pièces de rechange, veuillez appeler notre service à la clientèle au 1 877 447-4768, de 8 h 30 à 16 h 30 (HNC), du lundi au vendredi.

PIÈCE	DESCRIPCION	N.º DE PIÈCE
A	Anneau de soulèvement	40-07-453
B	Pare-étincelles en grillage	30-01-147
C	Grille de cuisson	30-01-247
D	Vasque de feu	30-01-248
E	Ring Bracket Pad	30-01-249
F	Ring Bracket	30-01-194
G	Decorative Ring	30-01-195
H	Pieds	30-01-250
I	Leg Support Ring	30-01-251
J	Tisonnier	40-04-409
AA-DD	Trousse de matériel	30-09-542
N/A	Manuel d'instructions	30-01-166

