

BLANCO VISION 210 SILGRANIT® Topmount Sink

Made of ultra durable granite composite material, BLANCO SILGRANIT® combines 80% natural granite, with high-quality acrylic for unmatched strength and durability.

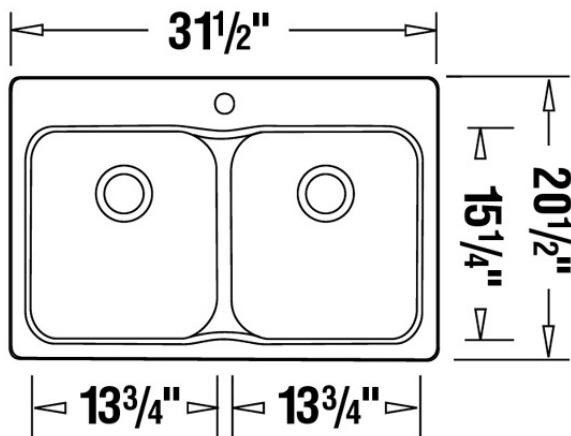

Model No.	Colour	Bowl Depth	
		Main	Secondary
400010	White	8 1/4" (210 mm)	8 1/4" (210 mm)
400012	Anthracite		
400307	Café		
401013	Biscotti		
401145	Truffle		

Material

BLANCO SILGRANIT®

Durable, patented composite material made of 80% natural granite

Specifications

Minimum Cabinet Size: 33" (840 mm)

Unsurpassed scratch, chip and stain resistance

Heat resistant to temperatures of up to 280°C (536°F)

Fade-proof; solid colour throughout

Rear positioned drain holes for max. usable bowl and cabinet space

2 large, equal size bowls

3.5" (90 mm) stainless steel strainers included

Matching Silgranit® colour faucets and optional accessories available

4 additional knock-out holes for accessories

Template included

Limited Lifetime Warranty

Made in Canada

BLANCO CANADA INC.

100 Corporation Drive, Brampton, ON L4V 1R3

Tel: 905-494-2400 Toll Free: 1-877-425-2626

Fax: 905-494-2425 Toll Free: 1-877-825-2626

www.blancocanada.com