

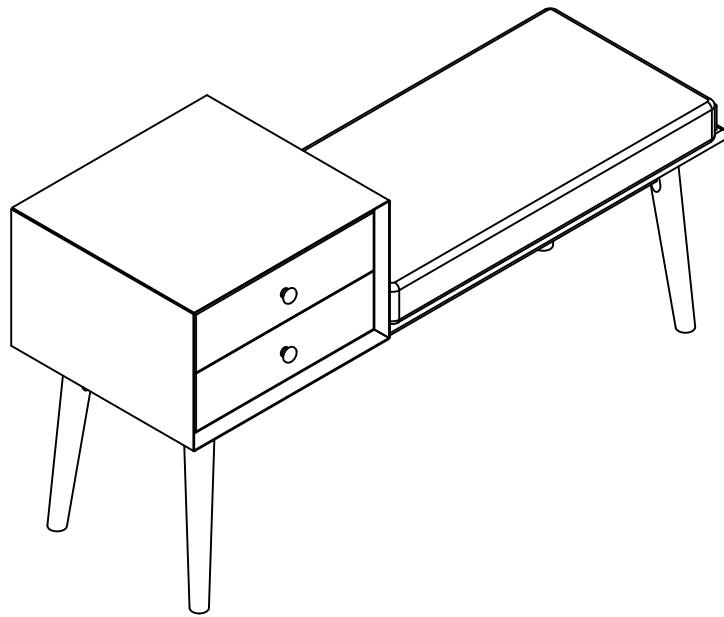

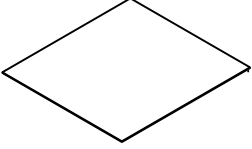

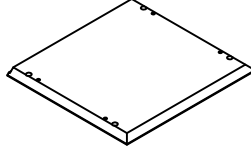

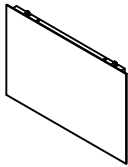

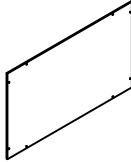

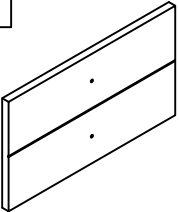
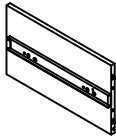
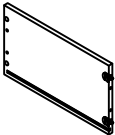
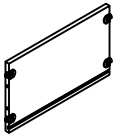
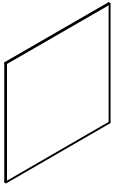
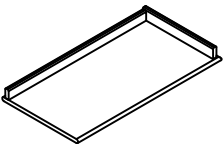
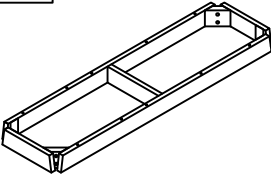
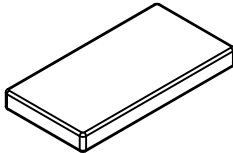

Entryway Bench
CF6012

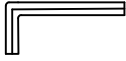

PART LIST

<p>A</p> 	<p>B</p> 	<p>C</p> 	<p>D</p> 	<p>E</p> 
<p>Top Panel of Cabinet 1 PC</p>	<p>Bottom Panel of Cabinet 1 PC</p>	<p>Side Panel of Cabinet 2 PCS</p>	<p>Back Panel of Cabinet 1 PC</p>	<p>Leg 4 PCS</p>
<p>F</p> 	<p>G</p> 	<p>H</p> 	<p>I</p> 	<p>J</p> 
<p>Front of Drawer 1 PC</p>	<p>Left Side Panel of Drawer 1 PC</p>	<p>Right Side Panel of Drawer 1 PC</p>	<p>Back Panel of Drawer 1 PC</p>	<p>Bottom Panel of Drawer 1 PC</p>
<p>K</p> 	<p>L</p> 	<p>M</p> 		
<p>Seat Panel 1 PC</p>	<p>Seat Frame 1 PC</p>	<p>Cushion 1 PC</p>		

HARDWARE LIST

<p>#1</p> 	<p>#2</p>  <p>Ø6x30</p>	<p>#3</p> 	<p>#4</p>  <p>M6x50</p>	<p>#5</p>  <p>M4</p>
<p>Flat Washer 9 PCS (Extra 1)</p>	<p>Wood Dowel 17 PCS (Extra 1)</p>	<p>Spring Washer 9 PCS (Extra 1)</p>	<p>Allen Bolt 19 PCS (Extra 1)</p>	<p>Allen Wrench 1 PC</p>
<p>#6</p>  <p>Ø7x2.5x12mm</p>	<p>#7</p> 	<p>#8</p>  <p>M4x18</p>		
<p>Screw 9 PCS (Extra 1)</p>	<p>Knob 2 PCS</p>	<p>Round Head Bolt 2 PCS</p>		

ADDITIONAL TOOLS (Not Provided)

Note: It is not recommended to use power tools during assembly.



Phillips Head Screwdriver

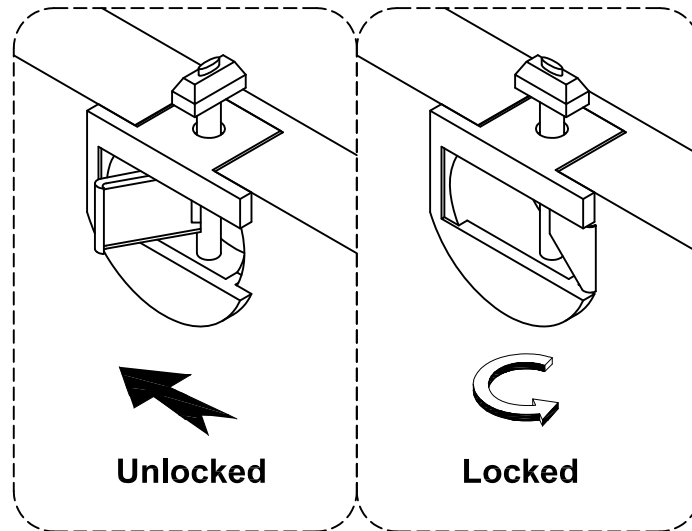

Please do not use tools to assemble this unit unless specifically indicated.

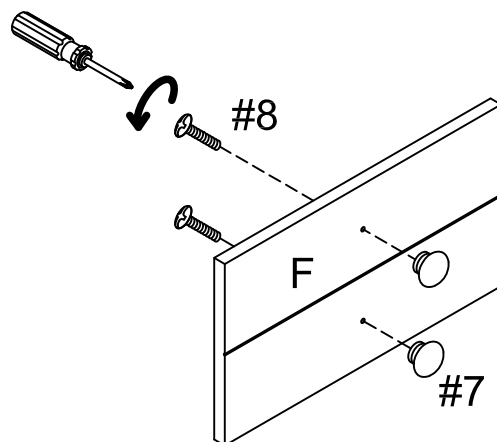

Reference the images above any time the instructions state "lock the hardware".
Note: Be sure to check all hardware is locked when completed.

Step 1. Attach knobs (part #7) to front of drawer (part F) using round head bolts (part #8) and phillips head screwdriver.



#7  x 2
#8  x 2

Step 2. Attach left side panel of drawer (part G) and right side panel of drawer (part H) to back panel of drawer (part I) using wood dowels (part #2) and lock the hardware. Slide bottom panel of drawer (part J) into the grooves of left side panel of drawer (part G) and right side panel of drawer (part H). Attach front of drawer (part F) to left side panel of drawer (part G) and right side panel of drawer (part H) using wood dowels (part #2) and lock the hardware.

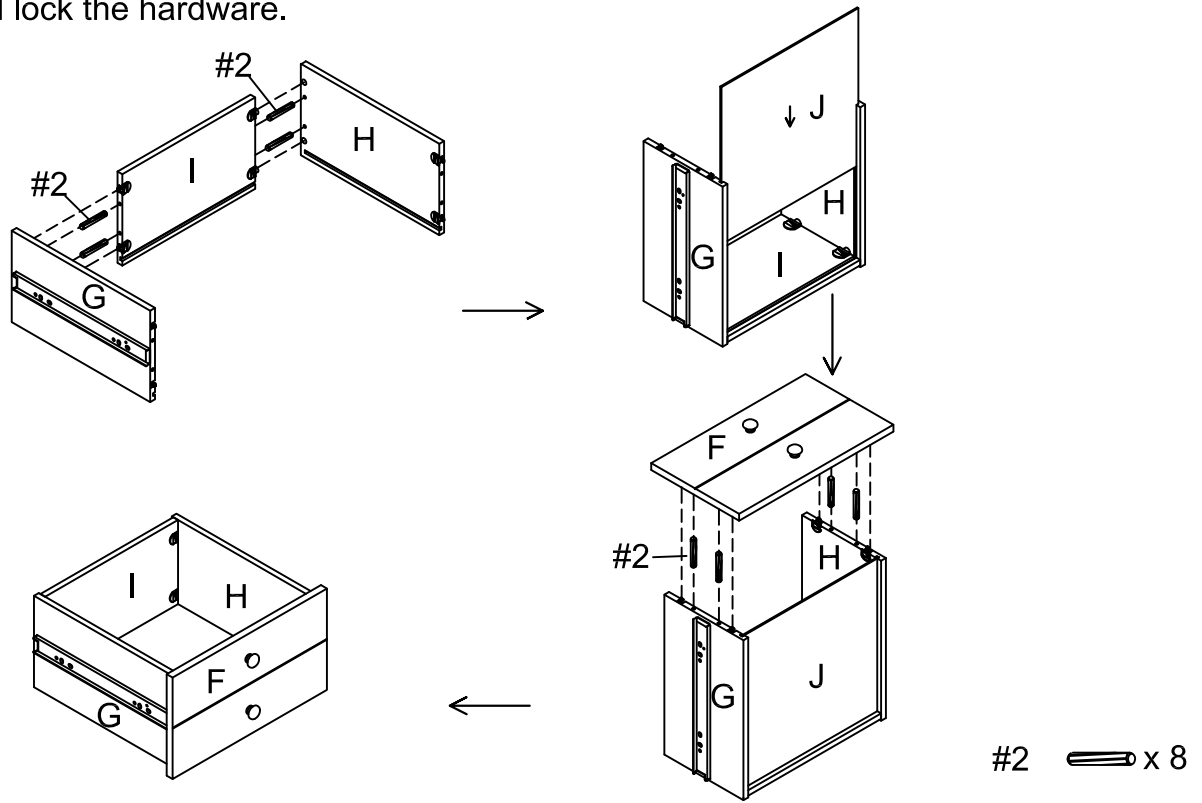

Step 3. Attach side panels of cabinet (part C) to bottom panel of cabinet (part B) using wood dowels (part #2) and lock the hardware. Attach top panel of cabinet (part A) to side panels of cabinet (part C) using wood dowels (part #2) and lock the hardware.

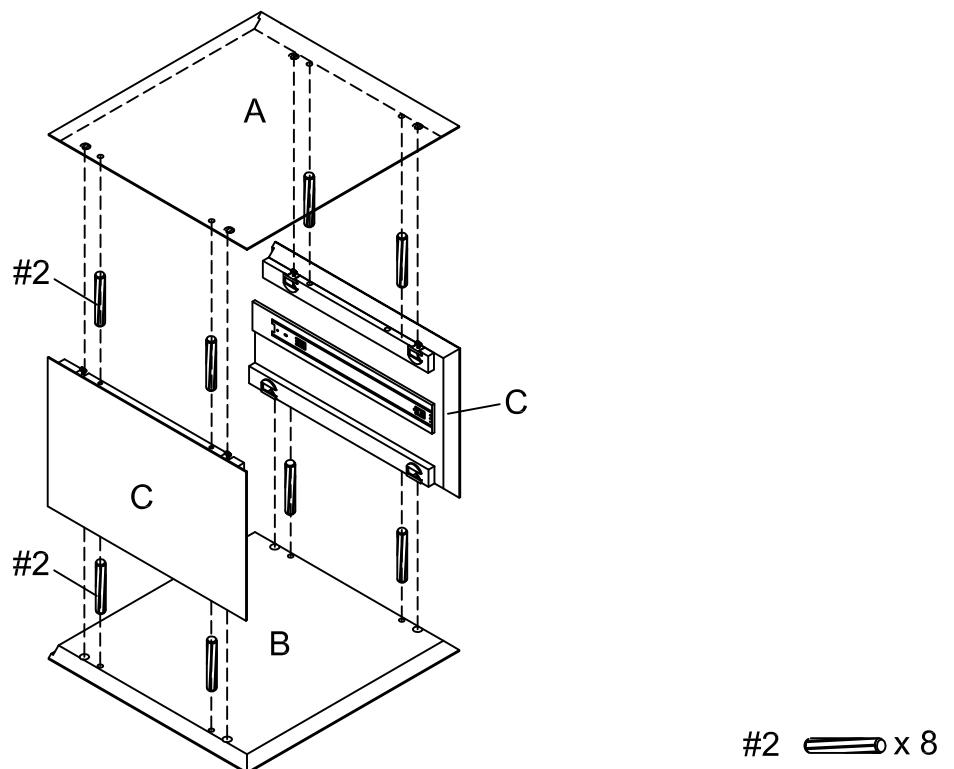



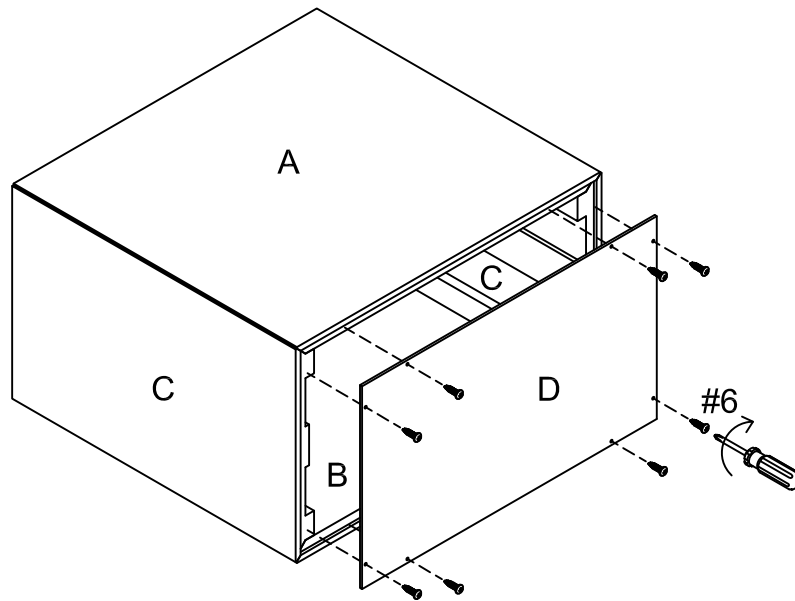

Step 4. Carefully turn unit around, and attach back panel of cabinet (part D) to top panel of cabinet (part A), side panels of cabinet (part C) and bottom panel of cabinet (part B) using screws (part #6) and phillips head screwdriver as shown.

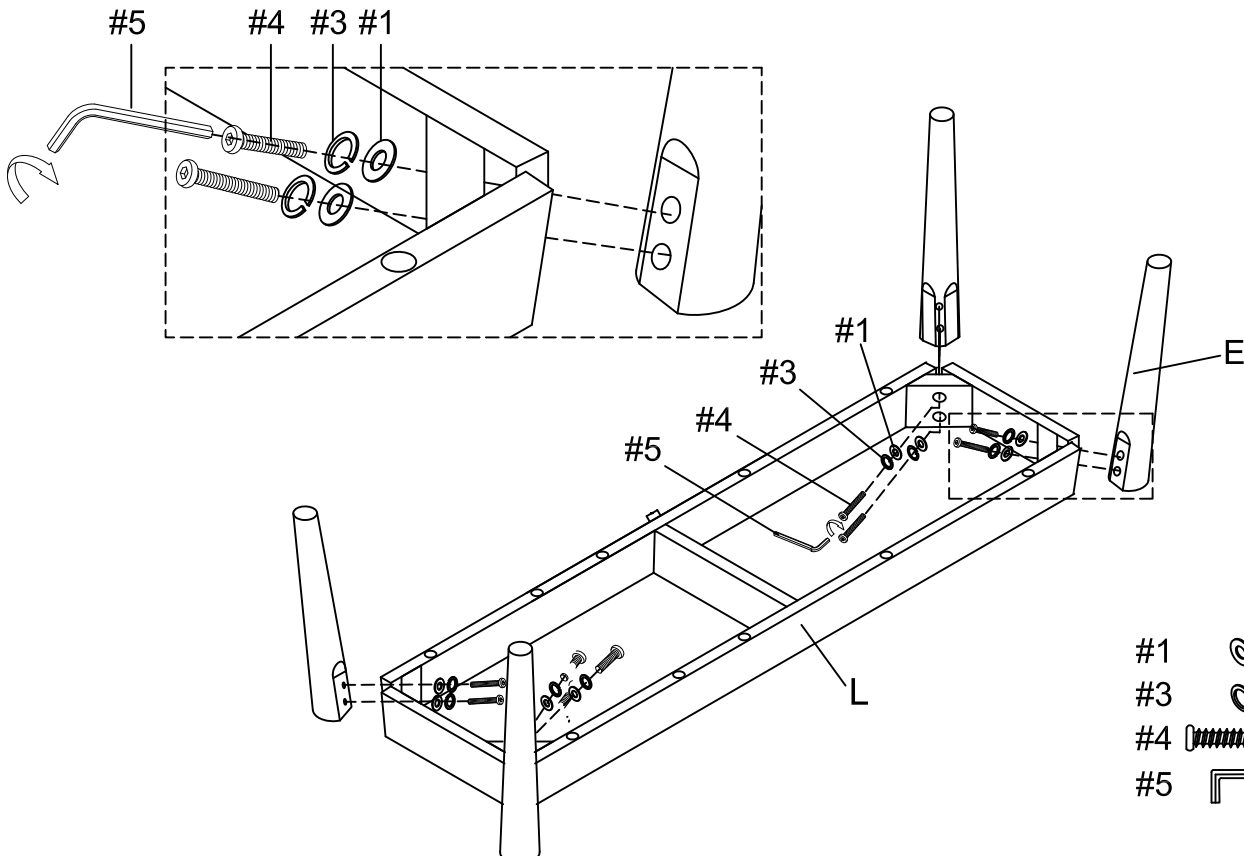

#6  x 8



Step 5. Attach legs (part E) to seat frame (part L) using flat washers (part #1), spring washers (part #3), allen bolts (part #4) and allen wrench (part #5).



#1  x 8
 #3  x 8
 #4  x 8
 #5  x 1

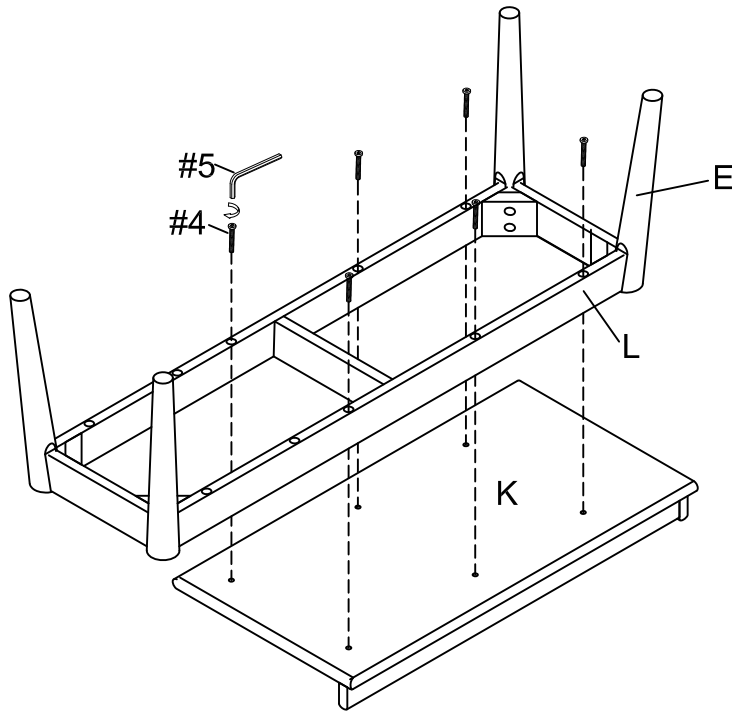

Step 6. Attach pre-assembled seat frame (part L) and legs (part E) to seat panel (part K) using allen bolts (part #4) and allen wrench (part #5).

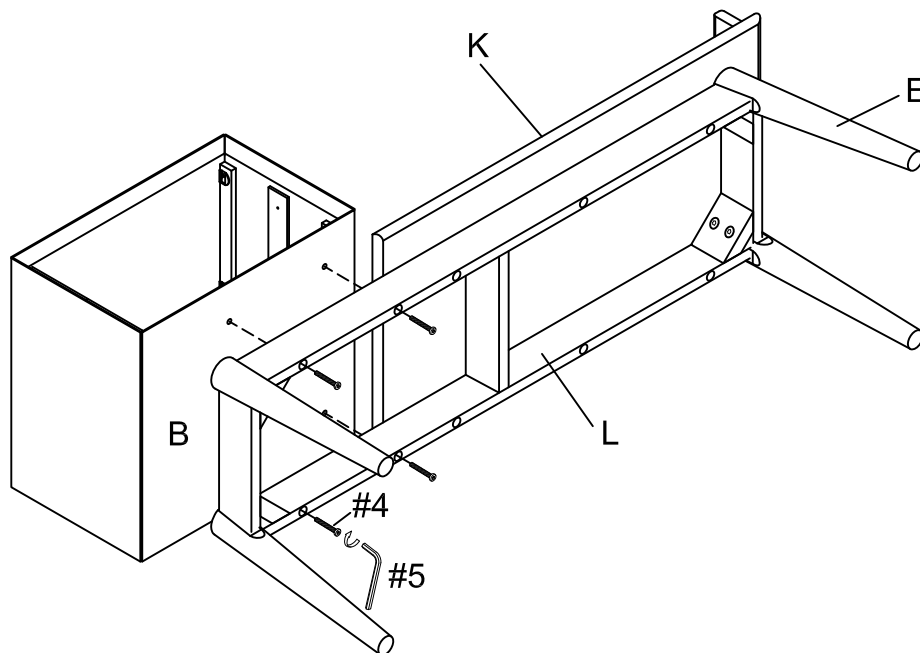

#4  x 6
#5  x 1

Step 7. Attach pre-assembled seat frame (part L) and legs (part E) to pre-assembled bottom panel of cabinet (part B) using allen bolts (part #4) and allen wrench (part #5).



#4  x 4
#5  x 1

Step 8. Insert drawer into cabinet box.

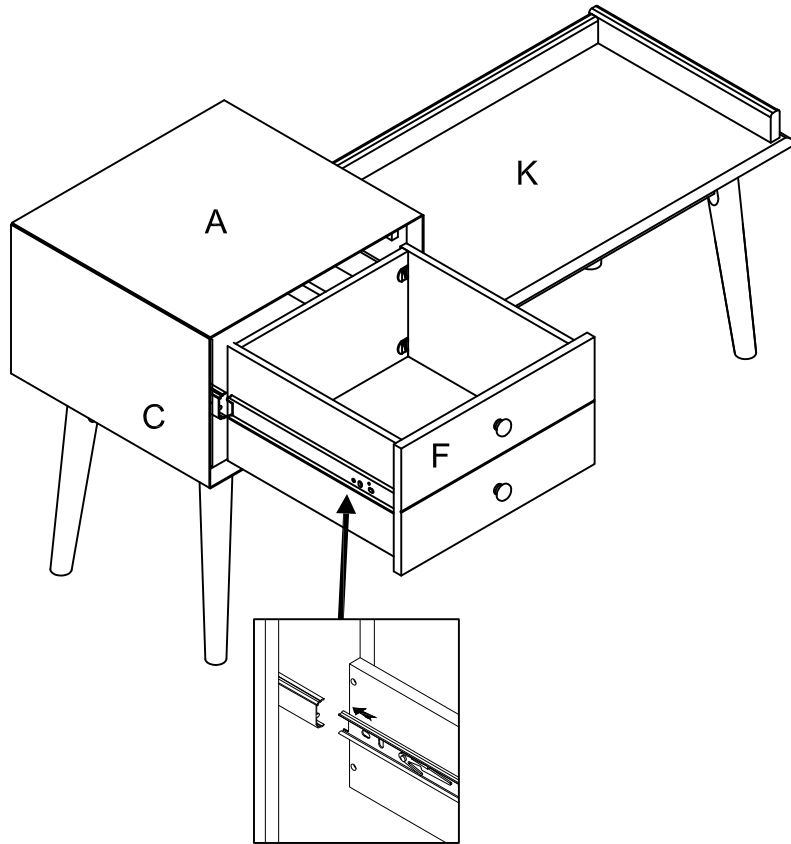

Step 9. Put the cushion (part M) into place.

