

CK481200TX  
Lazio Mirrored End Table

**Assembly Instructions**



**Southern**  
ENTERPRISES

For assistance with assembly, contact:  
Southern Enterprises, Inc.  
Customer Service: 1-800-633-5096  
service@seidal.com  
www.seidal.com

PO#:13456

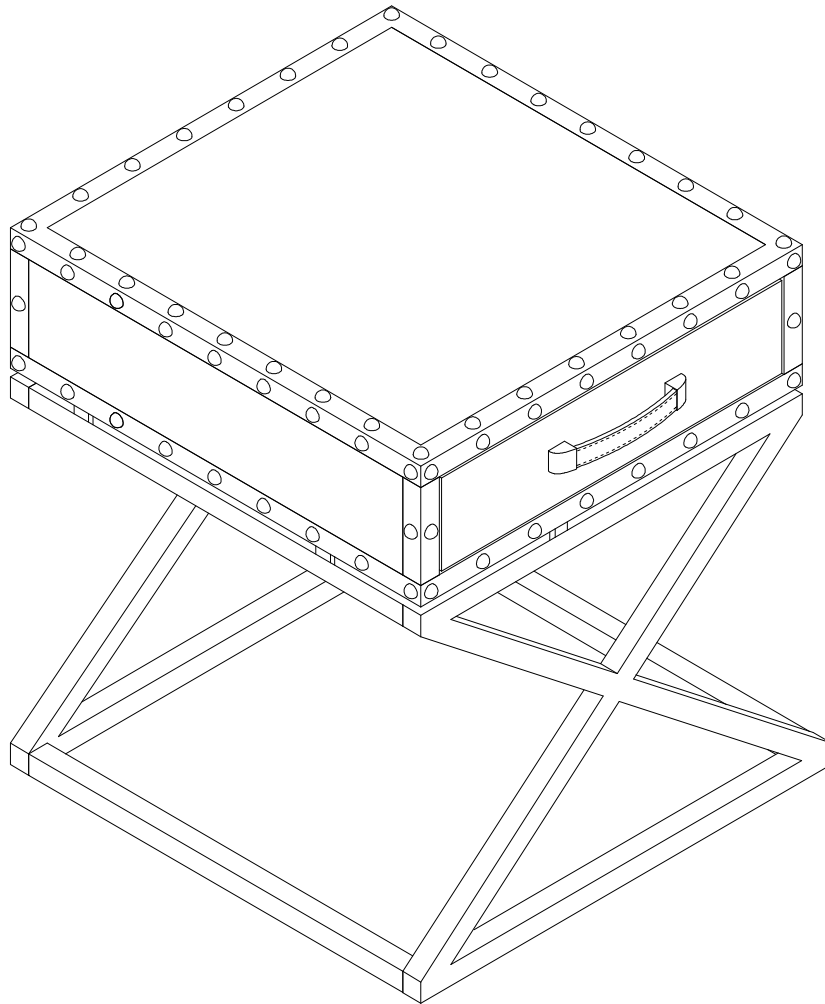



# Lazio Mirrored End Table

## Parts List

Please review all parts and hardware before disposing of any packaging.

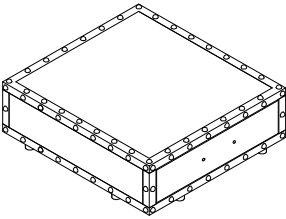
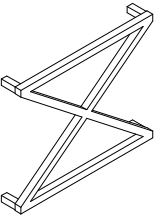
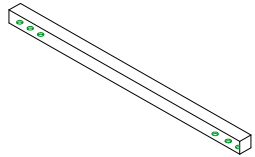
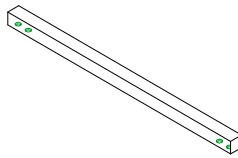
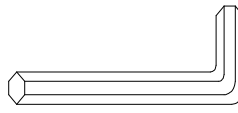
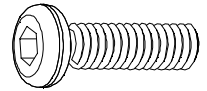
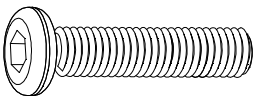
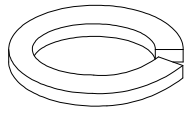
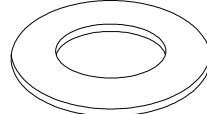
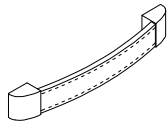
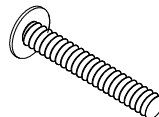
Before beginning assembly, separate each type of hardware. Carefully study the diagrams below and check that you have all parts indicated. Call Customer Service if missing hardware. Using the incorrect hardware will cause damage.

<p><b>A.</b>  Quantity of 1</p> <p><b>Top Frame</b></p>	<p><b>B.</b>  Quantity of 2</p> <p><b>Leg Frames</b></p>	<p><b>C.</b>  Quantity of 2</p> <p><b>Upper Rails</b></p>
<p><b>D.</b>  Quantity of 2</p> <p><b>Bottom Rails</b></p>	<p><b>1.</b>  Quantity of 1</p> <p><b>Allen Wrench</b></p>	<p><b>2.</b>  Quantity of 16</p> <p><b>Short Bolts</b> Ø 5/16"x1"L</p>
<p><b>3.</b>  Quantity of 4</p> <p><b>Long Bolts</b> Ø 5/16"x2"L</p>	<p><b>4.</b>  Quantity of 20</p> <p><b>Spring Washers</b></p>	<p><b>5.</b>  Quantity of 20</p> <p><b>Flat Washers</b></p>
<p><b>6.</b>  Quantity of 1</p> <p><b>Handle</b></p>	<p><b>7.</b>  Quantity of 2</p> <p><b>Handle Bolts</b> Ø 5/32"x1"L</p>	<p><b>8.</b>  Quantity of 2</p> <p><b>Rubber Gaskets</b></p>

**Care and Cleaning Instructions:**  
 Before using, wipe with a clean, dry cloth. Periodically apply furniture wax to renew the finish. Avoid rubbing or scratching the surface with rough or abrasive objects.

For replacement parts or questions, please call customer service at 1-800-633-5096.

**Assembly Tool Required No.2 Phillips Screwdriver (Not Included)**

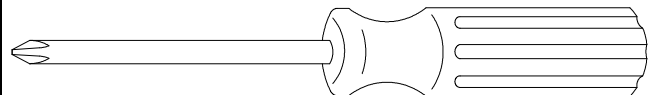

# Lazio Mirrored End Table Assembly Instructions

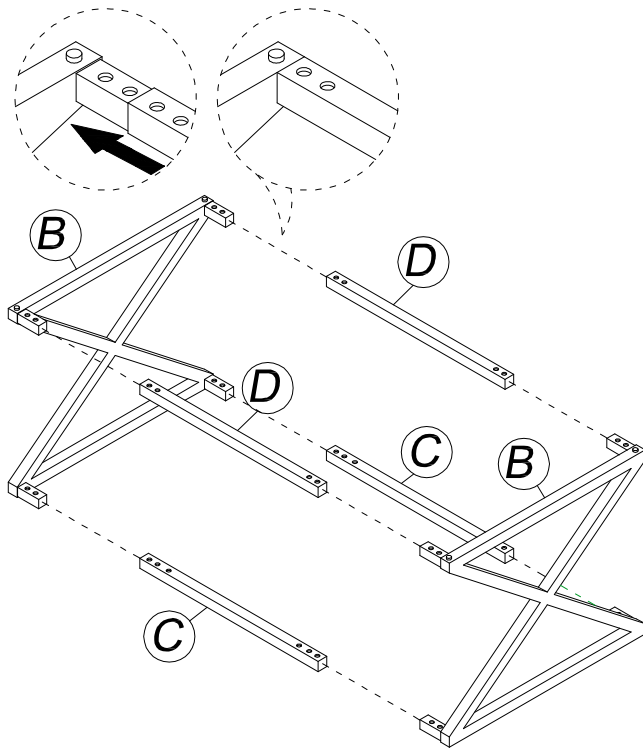

Figure 1

**Assemble with parts upside-down.**

Connect Upper Rails (C) and Bottom Rails (D) to Leg Frames (B) by hand.

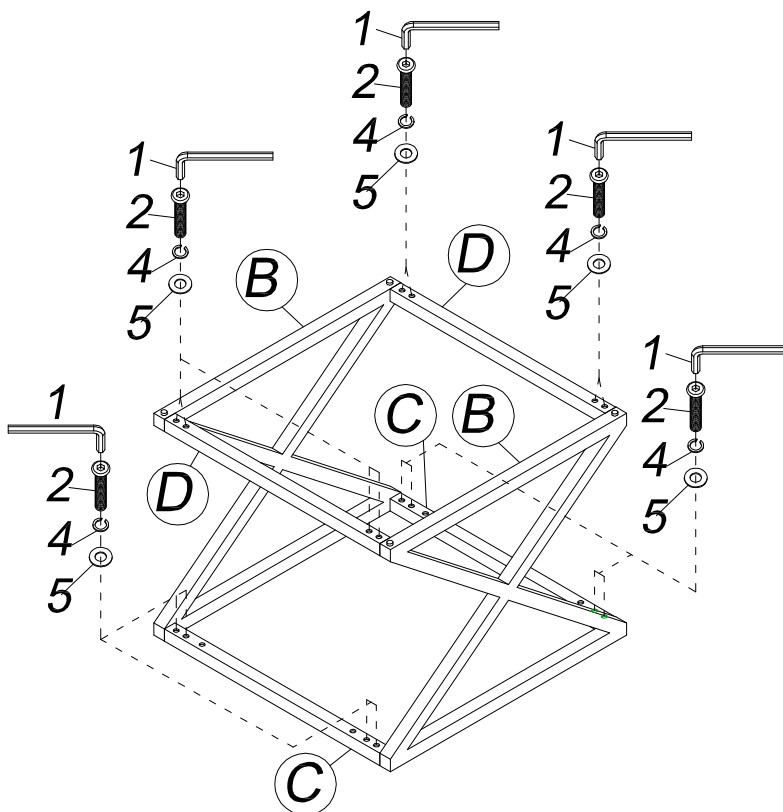

Figure 2

**Notice: Do not fully tighten Bolts until assembly is complete.**

Use Short Bolts (2), Spring Washers (4), and Flat Washers (5) to attach assembled base from Figure 1.

Tighten Bolts (2) with Allen Wrench (1).

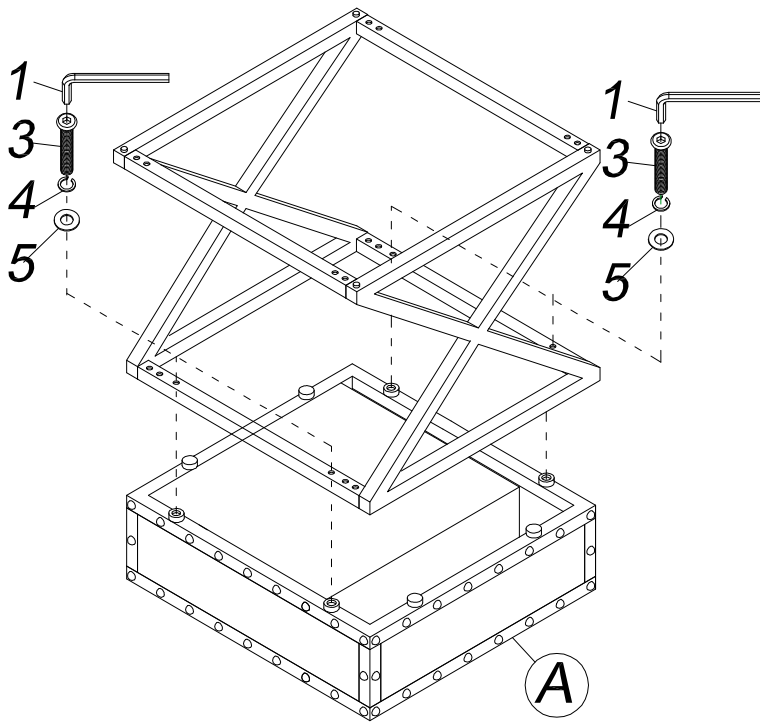

Figure 3

Place Top Frame (A) upside-down on a soft working surface.

Place assembled base onto Top Frame (A).

Attach base with Long Bolts (3), Spring Washers (4), and Flat Washers (5).

Fully tighten all Bolts (3) using Allen Wrench (1).

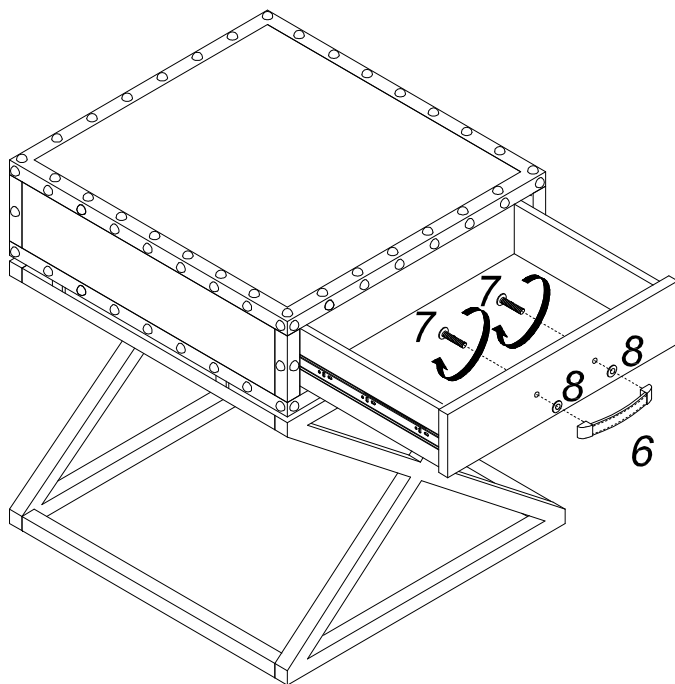

Figure 4

Carefully turn table upright.

Open drawer.

Attach Handles (6) onto drawer face using Handle Bolts (7) and Rubber Gaskets (8).

Tighten Handle Bolts (7) with a Phillips screwdriver.

**Caution: Please do not over tighten knobs. Stop when they start to feel tight.**

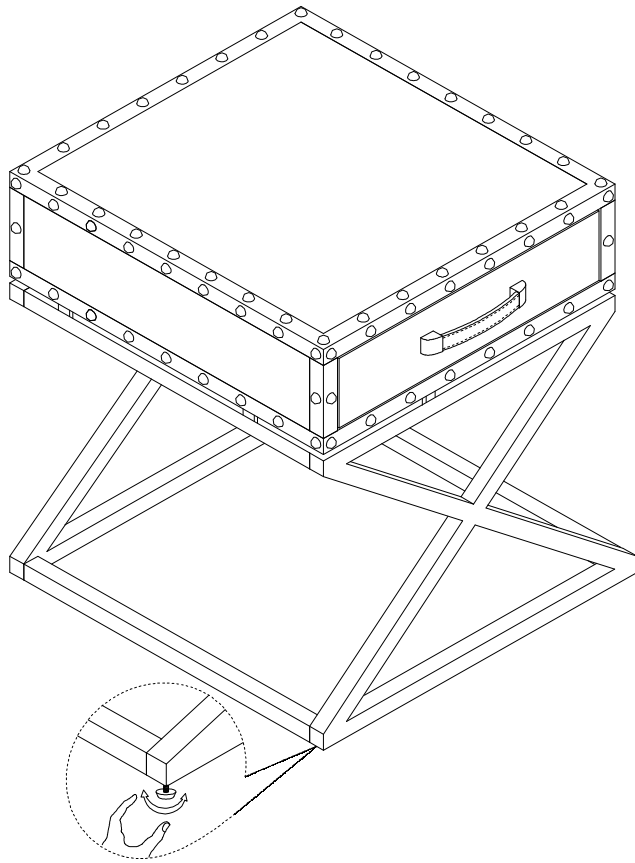

**Figure 5**

**Tip: If table is not level, adjust levelers on legs by hand as shown.**

Now your Lazio Mirrored End Table is ready to use!

# Parts Replacement Form

## Customer Information

Name \_\_\_\_\_

Address \_\_\_\_\_

City/State/Zip Code \_\_\_\_\_

Phone Number \_\_\_\_\_

Please indicate where you purchased this item: Store/Website/Catalog

\_\_\_\_\_

Please indicate color/size/style number:

\_\_\_\_\_

Style No	Parts Letter	Parts Description	Quantity Needed
_____	_____	_____	_____
_____	_____	_____	_____
_____	_____	_____	_____

Please immediately examine this product carefully. Any request for missing parts or damage replacement must be received within 90 days of your receipt of the product. Replacement, if available, will be honored within this time frame. Parts will not be available for items arriving fully assembled. We do not recommend modifying product(s) and we are not responsible for any damages due to product modification(s). If damages or missing parts are not reported within 90 days of your receipt, we are under no obligation to provide parts or replacement merchandise.

For product issues, please contact Southern Enterprises at 800-633-5096 (toll-free) / 972-869-0111 (Dallas), Mon-Fri 9am – 4pm CST, or email us at [service@seidal.com](mailto:service@seidal.com). Please ask for customer service representative for issues involving damages or replacement parts. Please ask for technical assistance representative for any issues with product and assembly/construction.

Please contact the retailer that you purchased from for returns.



**Southern**  
ENTERPRISES

Customer Service: 1-800-633-5096  
[service@seidal.com](mailto:service@seidal.com)

Southern Enterprises, Inc.  
600 Freeport Parkway, Suite 200  
Coppell, Texas 75019