

**KA327900TX**

**Morenci Kitchen Island  
Assembly Instructions**



**Southern  
ENTERPRISES**

For assistance with assembly contact:  
Southern Enterprises Inc.  
Customer Service 1-800-633-5096  
service@seidal.com  
www.seidal.com

**PO:13743**

Top supports up to 50 lb.

Shelf supports up to 30 lb.

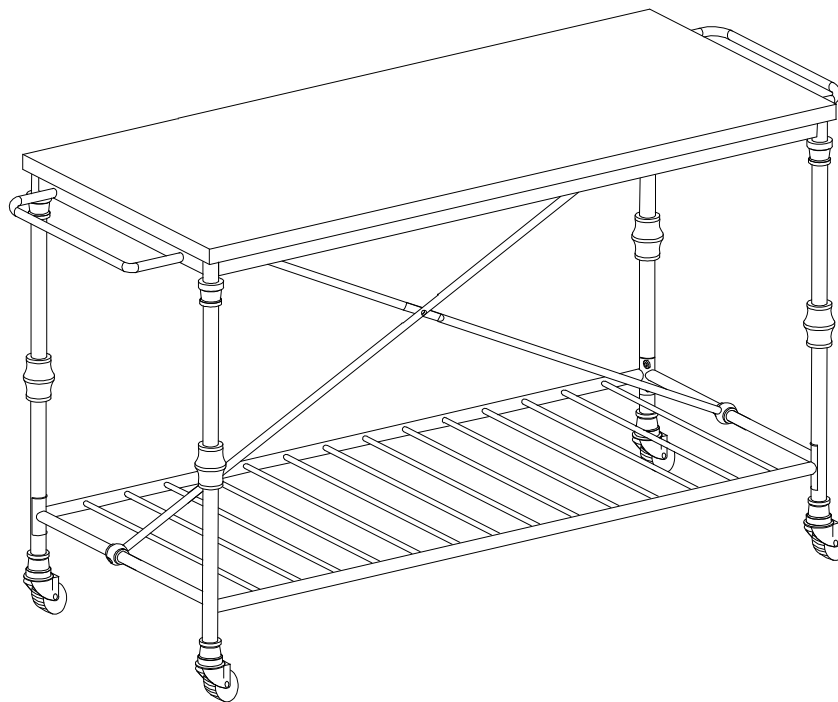





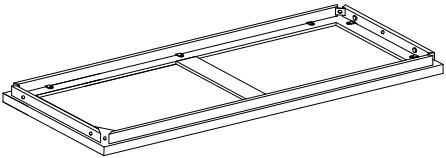
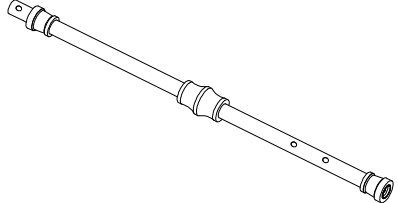
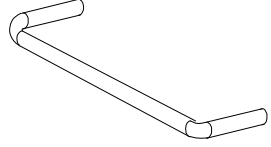
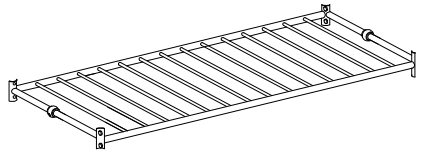
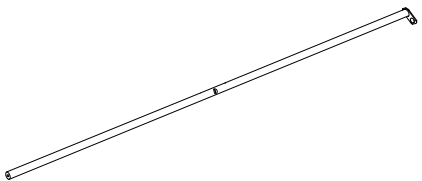
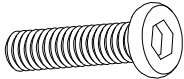
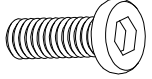
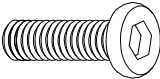

# KA327900TX

## Morenci Kitchen Island Parts List

Please review all parts and hardware before disposing of any packaging.

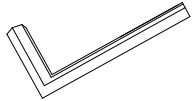
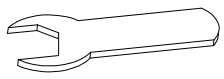
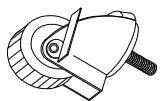
Before beginning assembly, separate each type of hardware. Carefully study the diagrams below and check that you have all parts indicated. Call Customer Service if missing hardware. Using the incorrect hardware will cause damage. You may receive extra hardware with your unit.

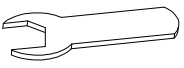
<p>A 1PC</p>  <p>Wood Top</p>	<p>B 4PCS</p>  <p>Supports</p>	<p>C 2PCS</p>  <p>Handles</p>	
<p>D 1PC</p>  <p>Bottom Shelf</p>	<p>E 2PCS</p>  <p>Crossbars</p>		
<p>1 10PCS</p>  <p>Bolts 1/4"x1"</p>	<p>2 10PCS</p>  <p>Bolts 1/4"x1/2"</p>	<p>3 1PC</p>  <p>Bolts 1/4"x3/4"</p>	<p>4 1PC</p>  <p>Nut</p>
<p>5 10PCS</p>  <p>Spring Washers</p>	<p>6 10PCS</p>  <p>Flat Washers</p>	<p>7 1PC</p>  <p>Wrench</p>	<p>8 1PC</p>  <p>Open Wrench</p>
<p>9 2PCS</p>  <p>Casters w/ Brake</p>	<p>10 2PCS</p>  <p>Casters w/o Brake</p>	<p>11</p>  <p>Small Open Wrench</p>	

**Care and Cleaning Instructions:**

Before using, wipe with a clean, dry cloth. Avoid rubbing or scratching the surface with rough or abrasive objects.

For replacement parts or questions, please Call Customer Service at 1-800-633-5096.

# KA327900TX

## Morenci Kitchen Island Assembly Instructions

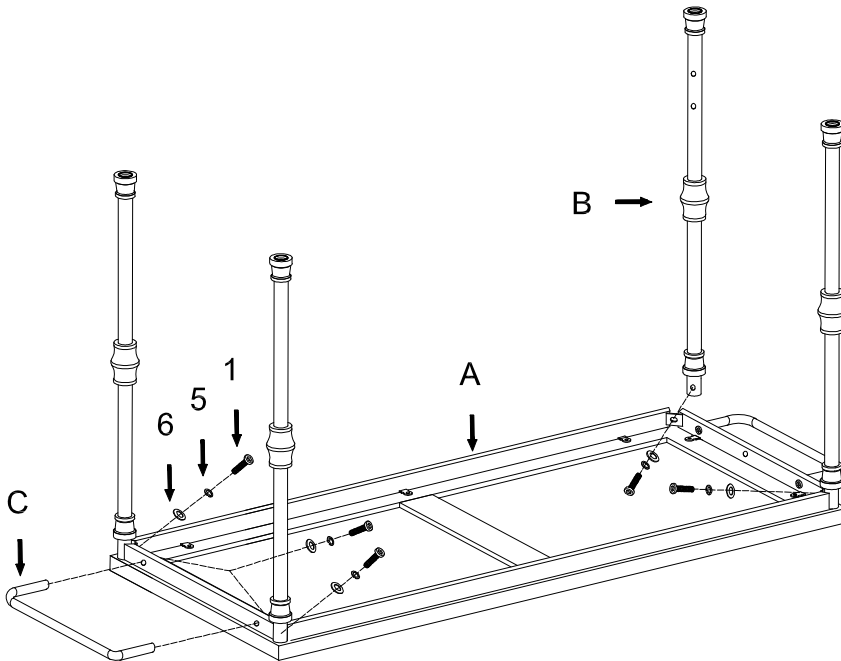

Figure 1

**Note:** Do not tighten bolts completely until step 3 is complete.

### Step 1:

Unit assembly should begin with parts turned upside down for Step 1.

Attach Supports (B) and Handles (C) to Wood Top (A) using Bolts (1), Spring Washers (5), and Flat Washers (6) as shown.

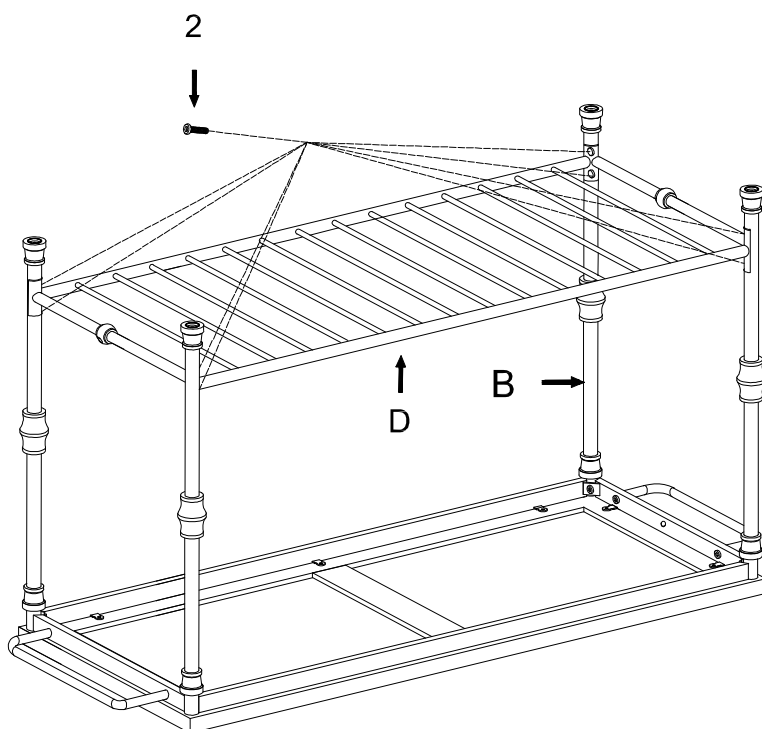
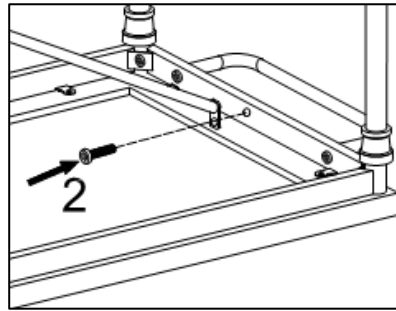
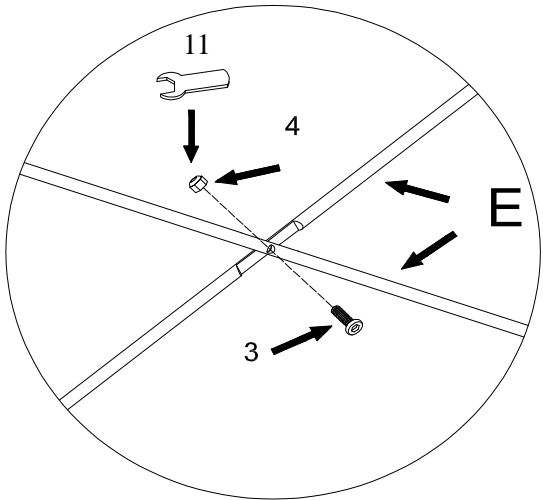
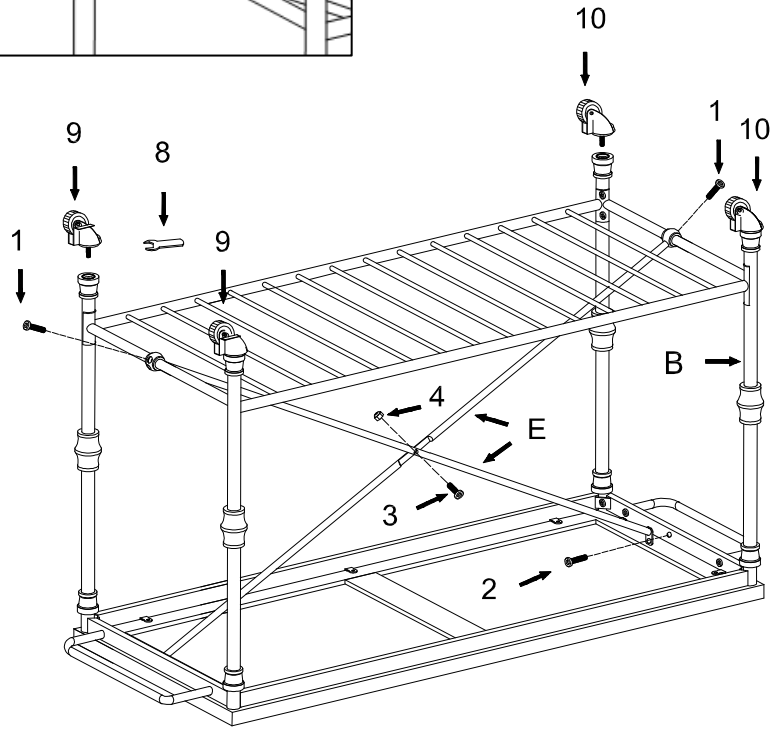
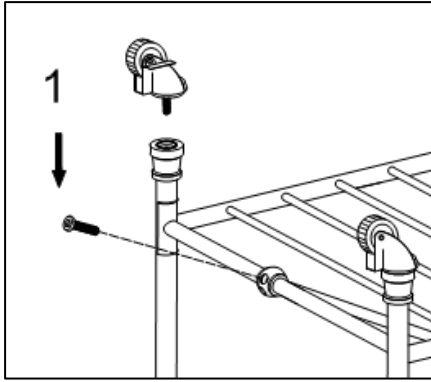

Figure 2

### Step 2:

Attach Bottom Shelf (D) to Supports (B) using Bolts (2) as shown.

**Note:** Assembly may be easier with the unit positioned on its side.



### Step 3

Insert Crossbars (E) into the holes on the short sides of Bottom Shelf (D) and fix Crossbars (E) with Bottom Shelf (D) using Bolts (1).

**Note: Please make sure the concave of Crossbars (E) face to each other**

Attach the other ends of Crossbars (E) to Wood Top (A) using Bolts (2), then, fix the X point using Bolt (3) and Nut (4) as shown.

Tighten Nut (4) with Small Open Wrench (11).

Tighten all bolts with Wrench (7).

Attach Casters w/Brake (9) and Casters w/o Brake (10) to Supports (B) with Open Wrench (8).

Turn the assembly unit upright.

Your Morenci Kitchen Island is ready to use.

Figure 3

# Parts Replacement Form

## Customer Information

Name \_\_\_\_\_

Address \_\_\_\_\_

City/State/Zip Code \_\_\_\_\_

Phone Number \_\_\_\_\_

Please indicate where you purchased this item: Store/Website/Catalog  
\_\_\_\_\_

Please indicate color/size/style number:  
\_\_\_\_\_

Style No

Parts Letter

Parts Description

Quantity Needed

Please immediately examine this product carefully. Any request for missing parts or damage replacement must be received within 90 days of your receipt of the product. Replacement, if available, will be honored within this time frame. Parts will not be available for items arriving fully assembled. We do not recommend modifying product(s) and we are not responsible for any damages due to product modification(s). If damages or missing parts are not reported within 90 days of your receipt, we are under no obligation to provide parts or replacement merchandise.

Please contact Southern Enterprises at 800-633-5096 or in Dallas 972-869-0111/ 9am – 4pm Mon-Fri Central time if you have product issues or email us at [service@seidal.com](mailto:service@seidal.com). Please ask for customer service representative for issues involving damages or replacement parts. Please ask for technical assistance representative for any issues with product and assembly/construction.

Please contact the retailer that you purchased from for returns.



**Southern**  
ENTERPRISES

Customer Service 1-800-633-5096  
[service@seidal.com](mailto:service@seidal.com)  
Southern Enterprises, Inc.  
600 Freeport Parkway, Suite 200  
Coppell, Texas 75019