

BC921800TX WHITE

BC931800TX DISTRESS BLACK

BC951800TX RED

BENCH WITH BROWN RATTAN BASKETS

Assembly Instructions



Southern
ENTERPRISES

For assistance with assembly contact:
Southern Enterprises, Inc.
Customer Service 1-800-633-5096
service@seidal.com
www.seidal.com

Max seat load: 300 lb.

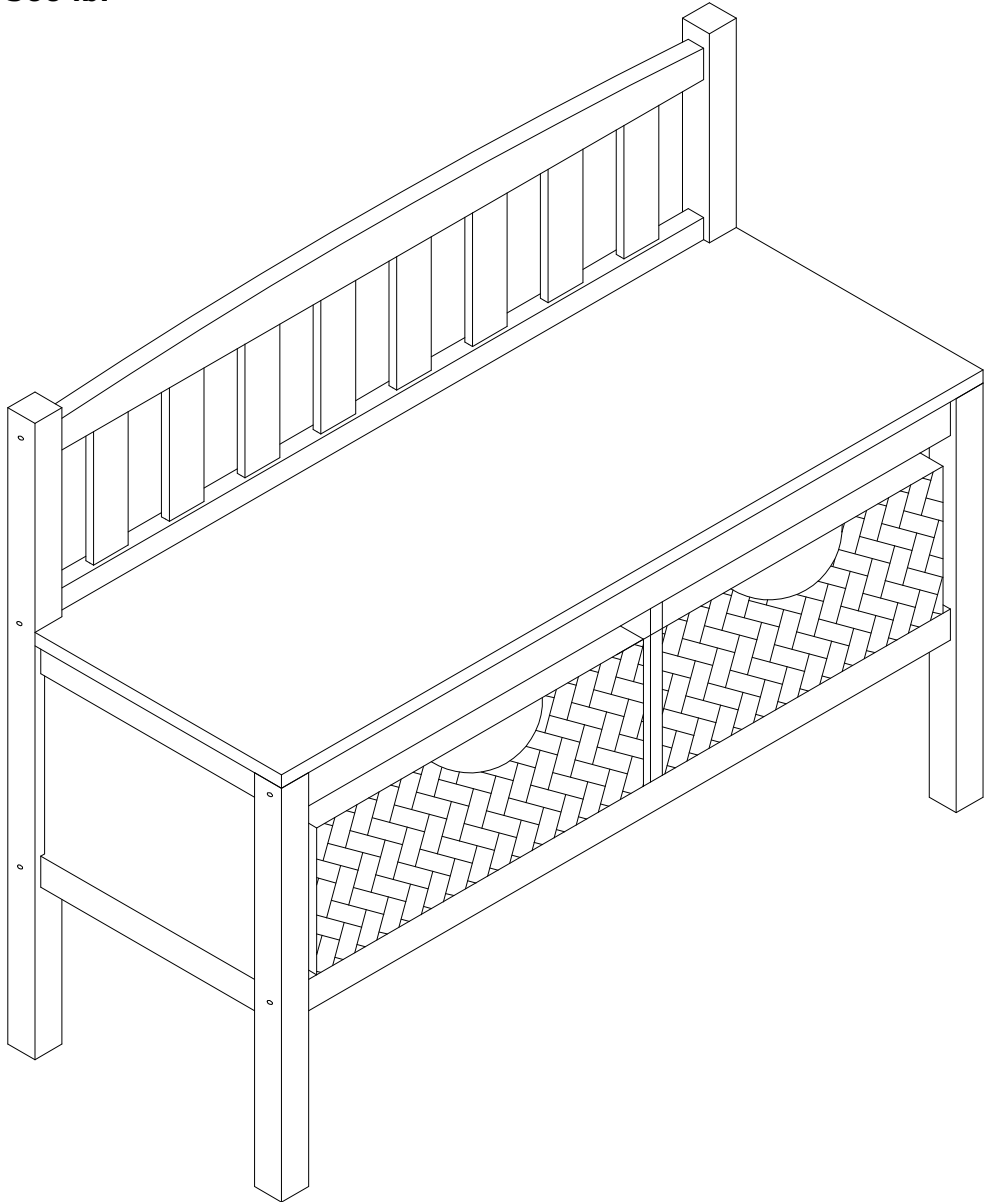

BENCH WITH BROWN RATTAN BASKETS

Parts List

Please review all parts and hardware before disposing of any packaging. Call Customer Service if missing hardware. Do not return to store/retailer. Using a screw that is too long will cause damage. Before beginning assembly, separate each type of screw. Carefully study the screw diagrams below. You may receive extra hardware with your unit.

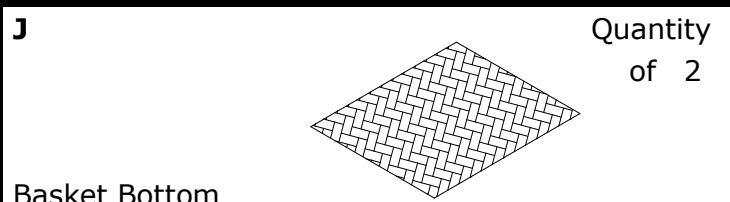
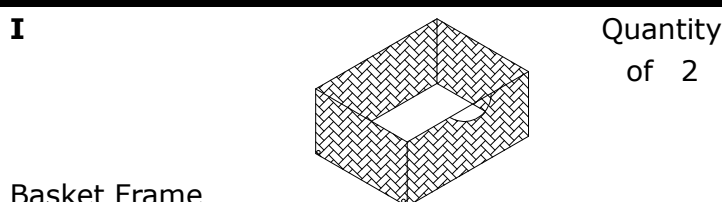
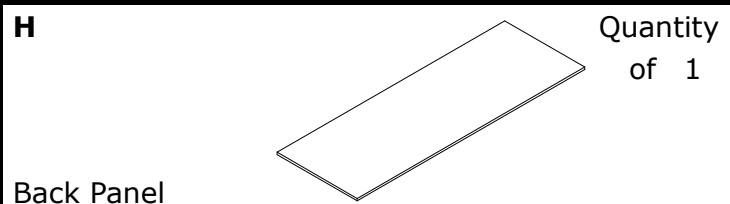
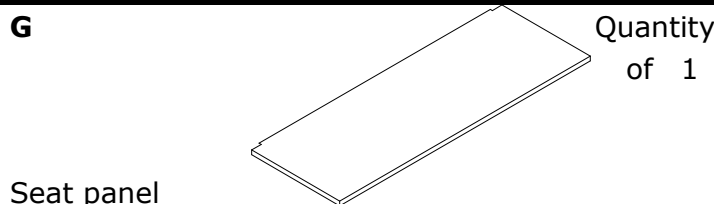
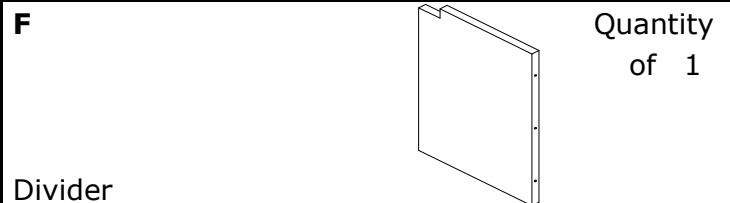
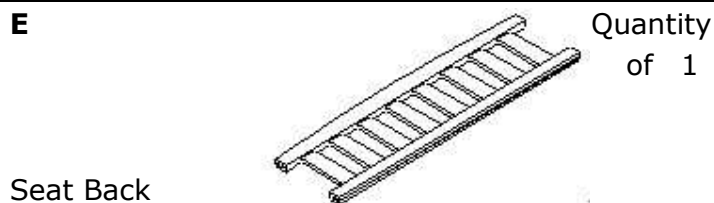
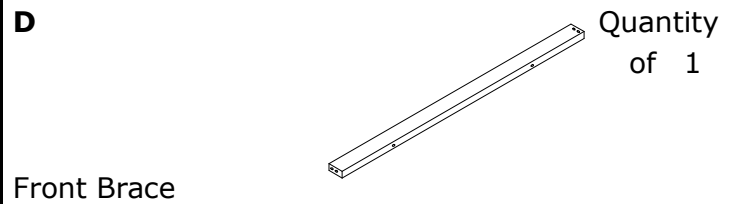
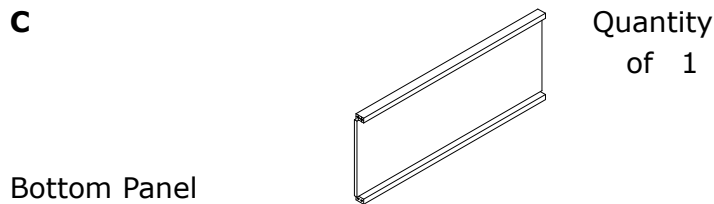
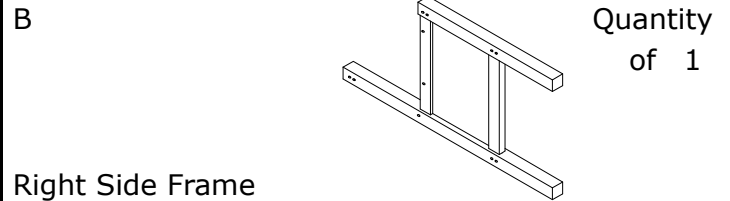
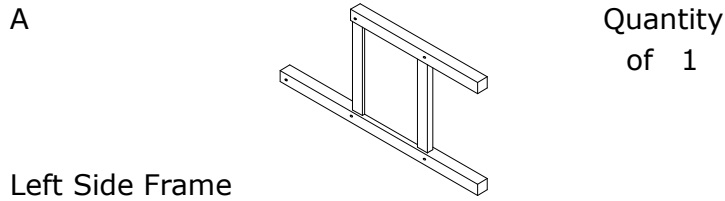

Care and Cleaning Instructions:
Before using, wipe with a clean, dry cloth. Periodically apply furniture wax to renew the finish. Avoid rubbing or scratching the surface with rough or abrasive objects.

For replacement parts or questions, please Call Customer Service at 1-800-633-5096 Do not return product to store, please call Manufacturer for assistance, questions or Parts.

Assembly Tool Required
No.2 Phillips Screwdriver (Not Included)

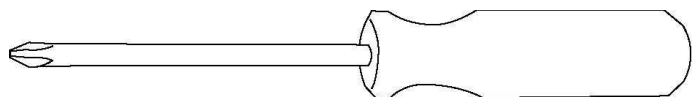

BENCH WITH BROWN RATTAN BASKETS

Parts List

Please review all parts and hardware before disposing of any packaging. Call Customer Service if missing hardware. Do not return to store/retailer. Using a screw that is too long will cause damage. Before beginning assembly, separate each type of screw. Carefully study the screw diagrams below. You may receive extra hardware with your unit.

1 Quantity of 10

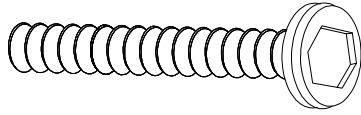

Bolt(1/4"*1-1/2")

2 Quantity of 12

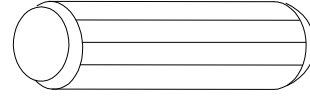

Wood Dowel (Ø8*40mm)

3 Quantity of 7

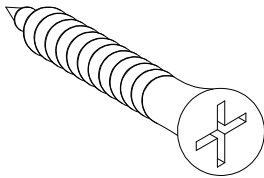

Wood Screw(8#*1-1/4")

4 Quantity of 10

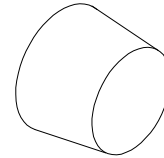

Wood Plug

5 Quantity of 8

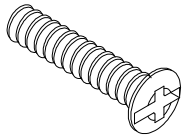

Small Bolt(Ø5/32*5/8")

6 Quantity of 1

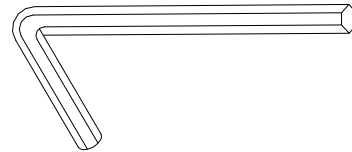

Allen Wrench

Care and Cleaning Instructions:

Before using, wipe with a clean, dry cloth. Periodically apply furniture wax to renew the finish. Avoid rubbing or scratching the surface with rough or abrasive objects.

For replacement parts or questions, please Call Customer Service at 1-800-633-5096 Do not return product to store, please call Manufacturer for assistance, questions or Parts.

Assembly Tool Required
No.2 Phillips Screwdriver (Not Included)

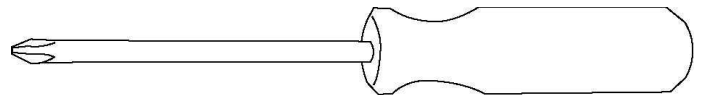

BENCH WITH BROWN RATTAN BASKETS

Assembly Instructions

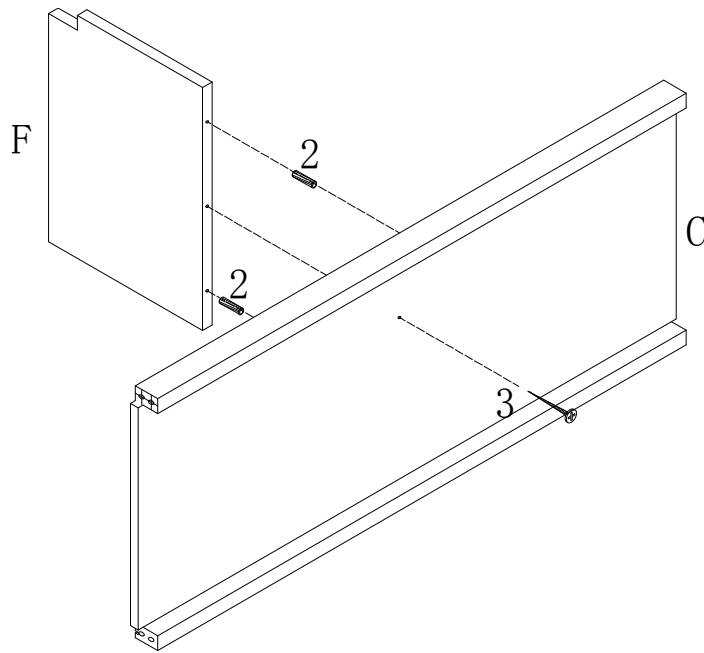

Figure 1

Assembly Instructions:

Wood may scratch easily, Be careful when assembling. Do not scratch.

Step 1 Unpack and lay parts on clean, padded surface like carpet or blanket. Check that you have all parts indicated on the front page.

Step 2 Connect the Bottom Panel (C) & the Divider (F) with 2pcs Wood Dowels (2) & 1pc Wood Screw (3) by using the screwdriver(not included in hardware list) as figure shown .

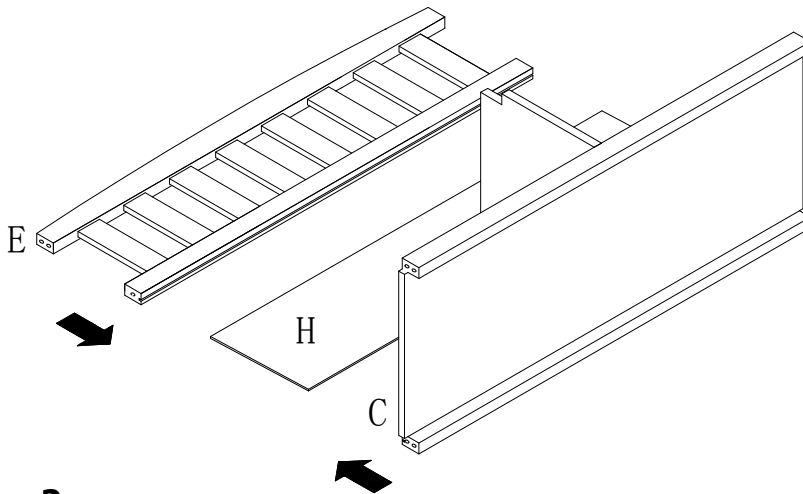

Figure 2

Insert the Back Panel (H) into the grooves in the Seat Back (E) and Bottom Panel (C) properly.

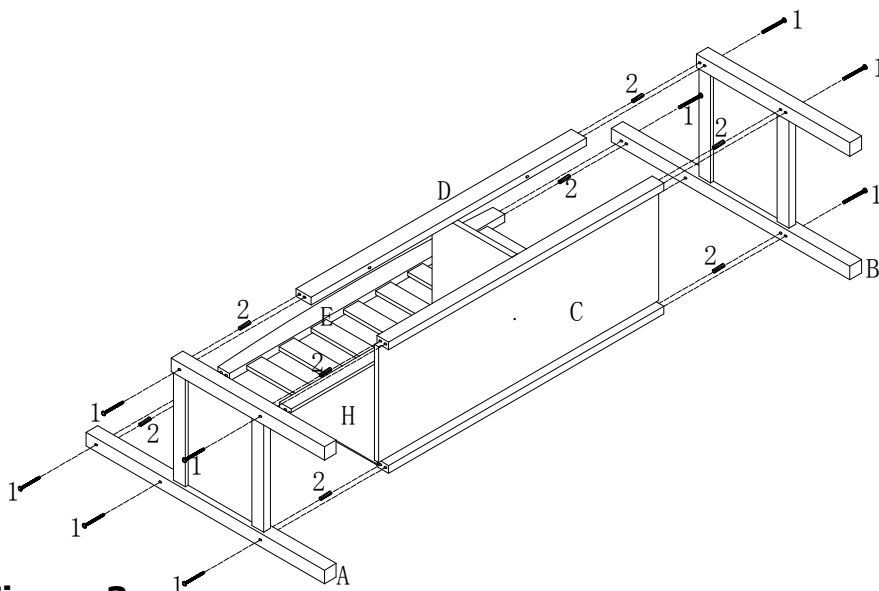

Figure 3

Attach the Left & Right Side Frame (A&B) , the Bottom Frame (C) to the well-assembled unit with 10pcs Bolts (1) & 8pcs Wood Dowels (2), tighten the bolts with Allen Wrench (6) as figure shown .

BENCH WITH BROWN RATTAN BASKETS

Assembly Instructions

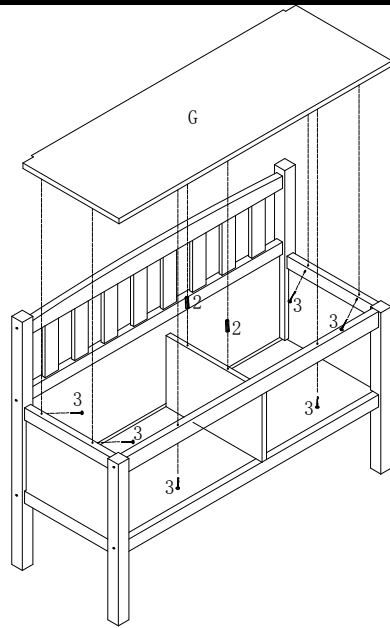

Figure 4

Connect the Seat Panel (G) with 2pcs Wood Dowels (2), 6pcs Wood Screws (3), tighten the screws with screwdriver (not included in hardware list) as figure shown.

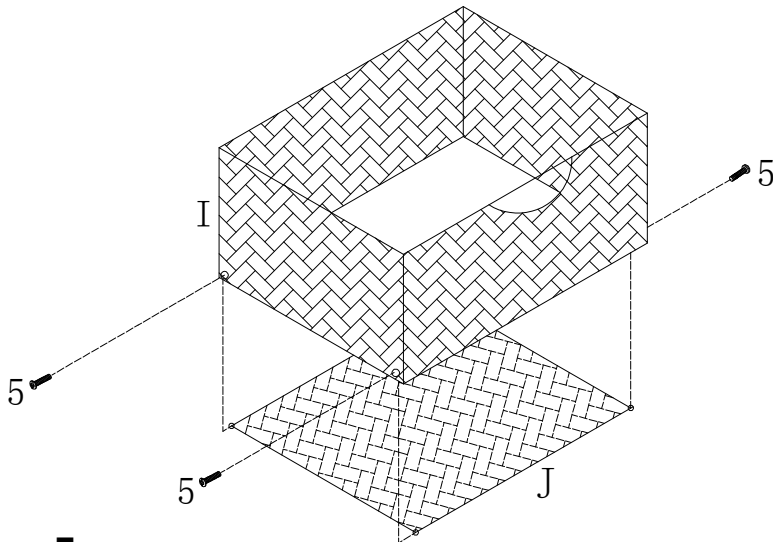

Figure 5

Attach the Basket Base (J) to the Basket Frame (I) with 4pcs Small Bolts (5) by using screwdriver (not included in hardware list) as figure shown.

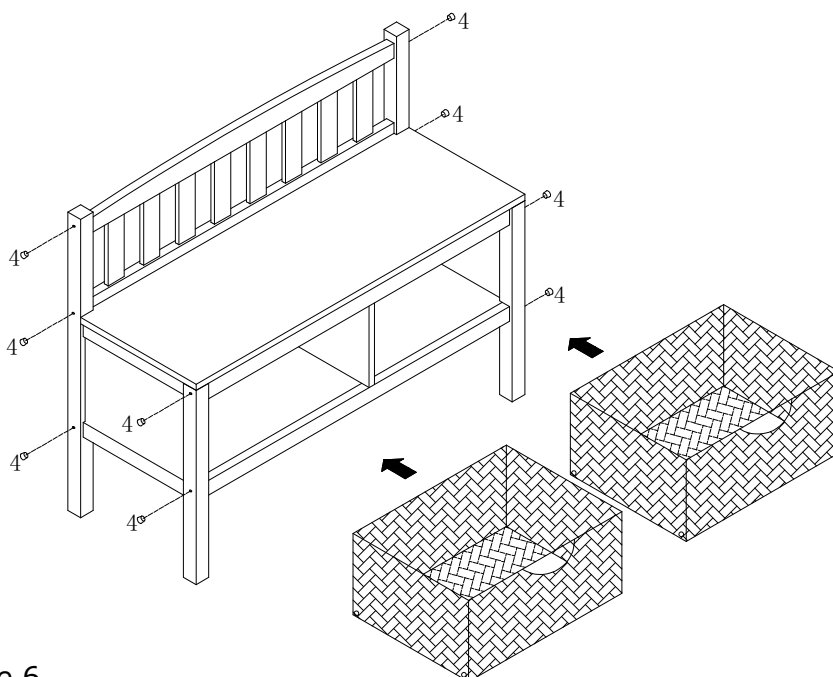

Figure 6

Cove the holes on the legs with 10pcs Wood Plugs (4) as figure shown, then put the baskets to the right position.

Parts Replacement Form

Customer Information

Name _____

Address _____

City/State/Zip Code _____

Phone Number _____

Please indicate where you purchased this item: Store/Website/Catalog

Please indicate color/size/style number:

Style No	Parts Letter	Parts Description	Quantity Needed
_____	_____	_____	_____
_____	_____	_____	_____
_____	_____	_____	_____

Please immediately examine this product carefully. Any request for missing parts or damage replacement must be received within 90 days of your receipt of the product. Replacement, if available, will be honored within this time frame. Parts will not be available for items arriving fully assembled. We do not recommend modifying product(s) and we are not responsible for any damages due to product modification(s). If damages or missing parts are not reported within 90 days of your receipt, we are under no obligation to provide parts or replacement merchandise.

Please contact Southern Enterprises at 800-633-5096 or in Dallas 972-869-0111/ 9am – 4pm Mon-Fri Central time if you have product issues or email us at service@seidal.com. Please ask for customer service representative for issues involving damages or replacement parts. Please ask for technical assistance representative for any issues with product and assembly/construction.

Please contact the retailer that you purchased from for returns.



Southern
ENTERPRISES

Customer Service 1-800-633-5096

service@seidal.com

Southern Enterprises, Inc.

600 Freeport Parkway, Suite 200

Coppell, Texas 75019