

KA327700TX  
MARTINVILLE KITCHEN  
CART - White  
Assembly Instructions

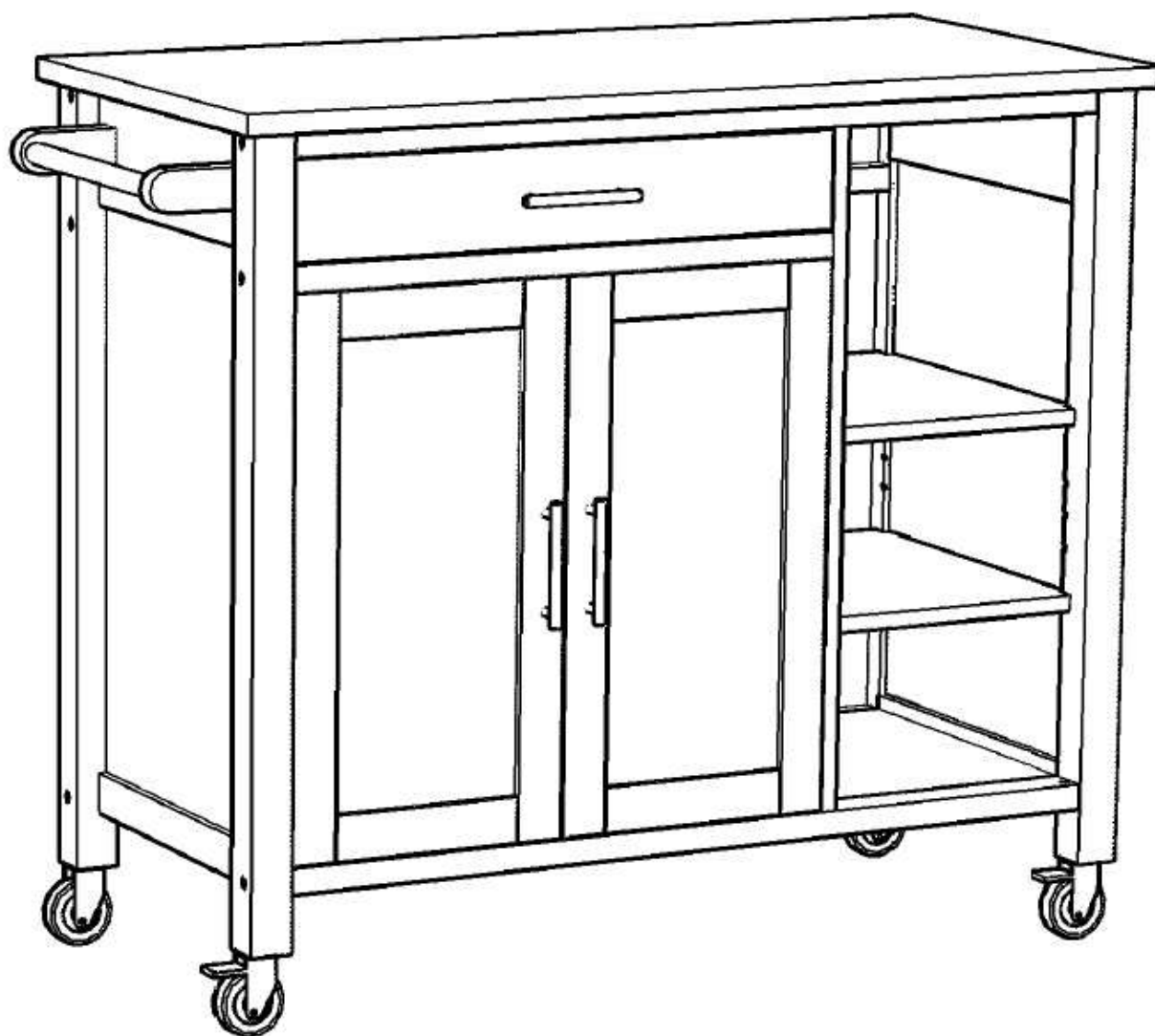

Southern  
ENTERPRISES

For assistance with assembly contact:  
Southern Enterprises Inc.  
Customer Service 1-800-633-5096  
[service@seidal.com](mailto:service@seidal.com)  
[www.seidal.com](http://www.seidal.com)









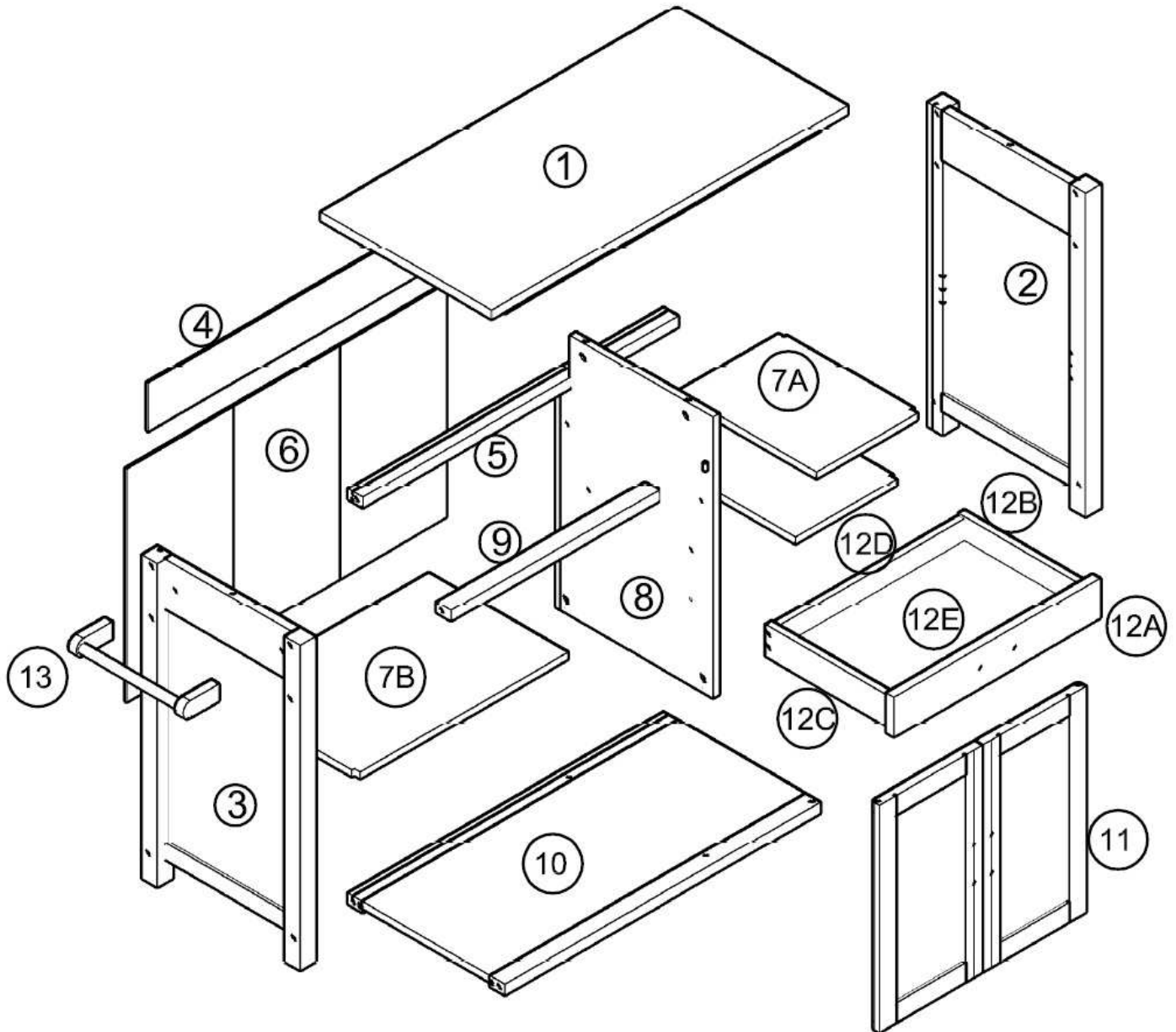



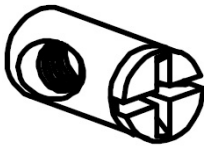

# MARTINVILLE KITCHEN CART - White

## Parts List

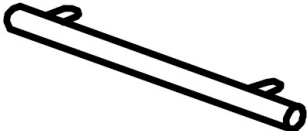
Please review all parts and hardware before disposing of any packaging. Call Customer Service if missing hardware. Using a screw that is too long will cause damage. Before beginning assembly, separate each type of screw. Carefully study the Screw diagrams below. You may receive extra hardware with your unit.



No.	Description	Qty	No.	Description	Qty
1	Table Top	1 pc	9	Front Apron	1 pc
2	Side Frame (R)	1 pc	10	Bottom Panel	1 pc
3	Side Frame (L)	1 pc	11	Door	2 pcs
4	Upper Back Panel	1 pc	12A	Drawer Front	1 pc
5	Back Apron	1 pc	12B	Drawer Side Apron (R)	1 pc
6	Back Panel	3 pcs	12C	Drawer Side Apron (L)	1 pc
7A	Shelf (R)	2 pcs	12D	Drawer Back Panel	1 pc
7B	Shelf (L)	1 pc	12E	Drawer Bottom Panel	1 pc
8	Center Panel	1 pc	13	Towel Bar	1 set

<p><b>A</b></p>  <p>Long Bolt ( M6 X 50 )</p>	<p>Quantity of 11</p> <p><b>B</b></p>  <p>Barrel Nut</p> <p>Quantity of 4</p>
<p><b>C</b></p>  <p>Small Bolt ( M6 X 40 )</p>	<p>Quantity of 3</p> <p><b>D</b></p>  <p>Spring Washer</p> <p>Quantity of 2</p>
<p><b>E</b></p>  <p>Flat Washer</p>	<p>Quantity of 2</p> <p><b>F</b></p>  <p>Cam Bolt</p> <p>Quantity of 4</p>
<p><b>G</b></p>  <p>Cam Lock</p>	<p>Quantity of 4</p> <p><b>H</b></p>  <p>Metal Pin</p> <p>Quantity of 12</p>
<p><b>I</b></p>  <p>Bar Handle</p>	<p>Quantity of 3</p> <p><b>J</b></p>  <p>Handle Screw X 22mm</p> <p>Quantity of 6</p>
<p><b>K</b></p>  <p>Door Spring</p>	<p>Quantity of 4</p> <p><b>L</b></p>  <p>Allen Key</p> <p>Quantity of 1</p>
<p><b>M</b></p>  <p>H-Profile</p>	<p>Quantity of 1</p> <p><b>N</b></p>  <p>Wood Screw X 32mm</p> <p>Quantity of 8</p>

**O** Quantity of 11



Wood Button

**P** Quantity of 2



Castor With Lock

**Q** Quantity of 2

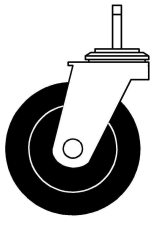

Castor Without Lock

Care and Cleaning Instructions:  
Before using, wipe with a clean, dry cloth.  
Periodically apply furniture wax to renew the finish. Avoid rubbing or scratching the surface with rough or abrasive objects.

For replacement parts or questions, please  
Call Customer Service at 1-800-633-5096.

**Assembly Tool Required**  
**No.2 Phillips Screwdriver (Not Included)**

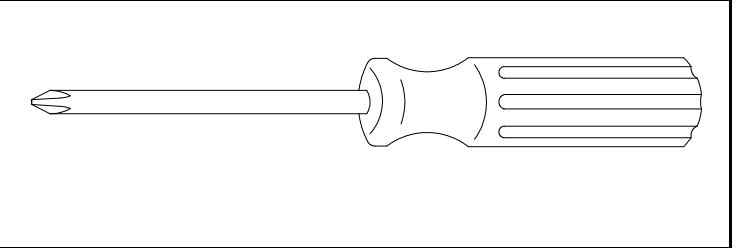

# Martinville Kitchen Cart - White

## Assembly Instructions

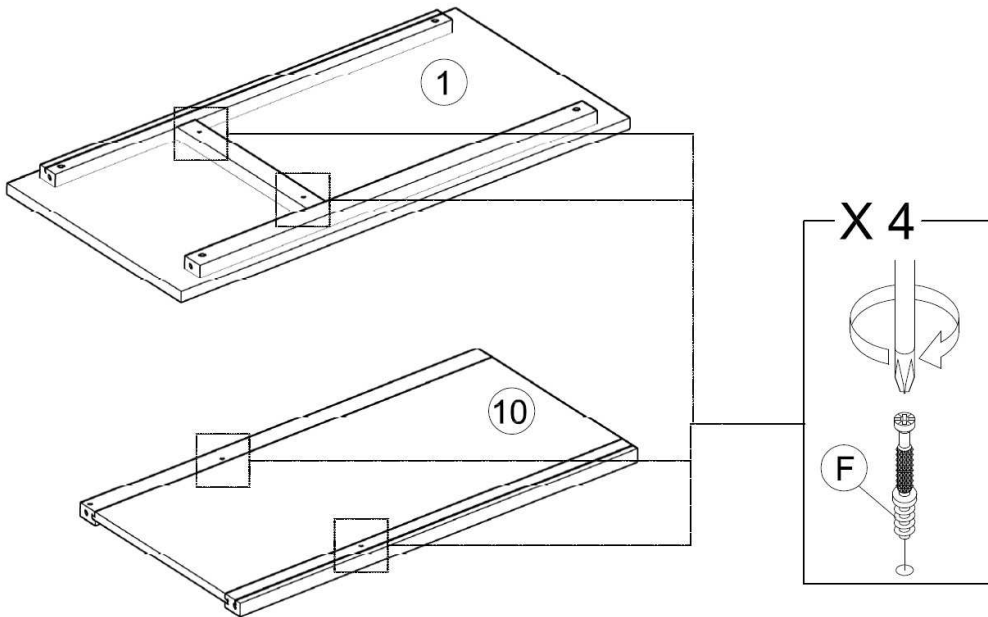

Figure 1

Attach Cam Bolts (F) into Table Top (1) and Bottom Panel (10) as shown. Tighten using Screwdriver.

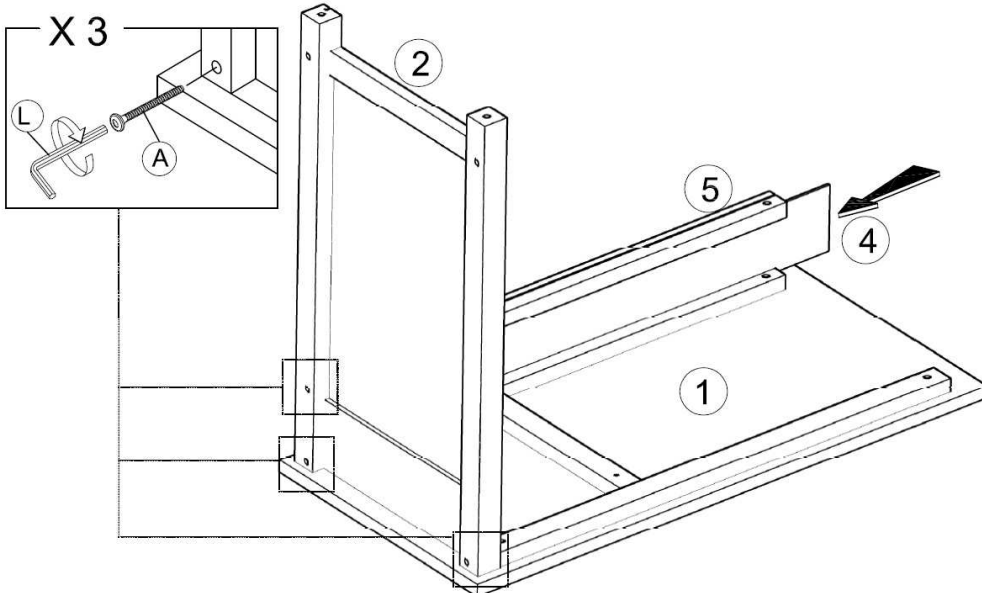
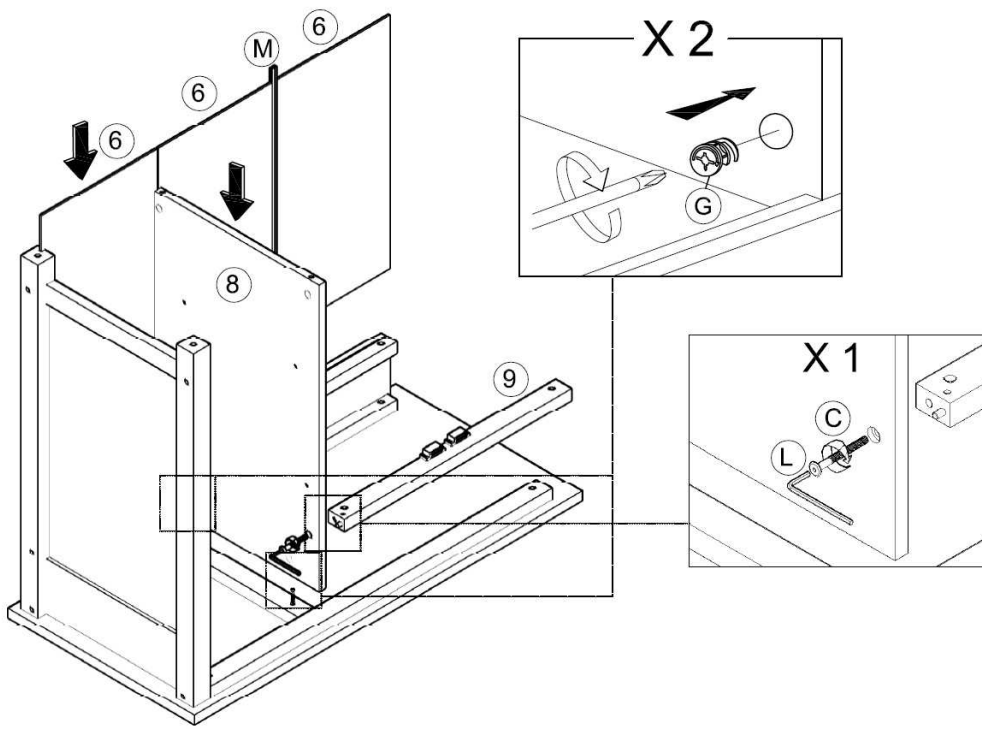

Figure 2

Attach Side Frame (R) (2) to Table Top (1) with Long Bolts (M6x50) (A). Tighten using Allen Wrench (L) provided.

Attach Back Apron (5) to the unit with Long Bolts (M6x50) (A). Tighten using Allen Wrench (L) provided.

Slide Upper Back Panel (4) into groove between the aprons as shown.



**Figure 3**

Insert Center Panel (8) onto the attached Cam Bolts (F) on the unit and secure using Cam Locks (G). Tighten Cam Locks (G) using Screwdriver.

Attach Front Apron (9) to Center Panel (8) as shown by using Short Bolt (M6 X 40) (C). Tighten using Allen Wrench (L) provided.

Slide 1 Pc Back Panel (6) between Side Frame (2) and Centre Panel (8).

Connect 2pcs of Back Panels (6) with H-Profile (M) as shown. Then slide into the grooves of Centre Panel (8) and Back Apron (5) as shown.

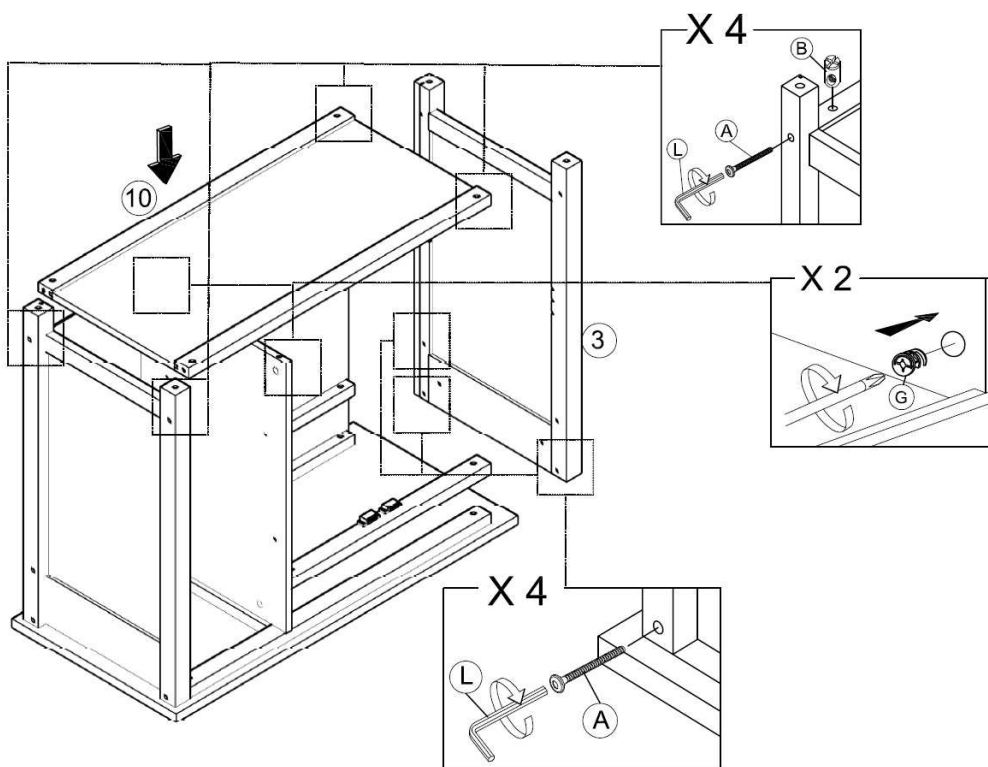

**Figure 4**

Attach Side Frame (L) (3) to the unit by inserting Long Bolts (M6x50) (A) into Top Panel (1). Tighten using Allen Wrench (L) provided.

Place Bottom Panel (10) onto the unit and align the Cam Bolt (which assembled in Figure 1) to the Center Panel (8). Tighten using Cam Locks (G) using Screwdriver.

Secure Bottom Panel (10) to Side Frames using Long Bolts (M6 X 5) (A) and insert Barrel Nut (B) into Bottom Panel (10).

**Note: Align the hole of the Barrel Nuts towards bolts direction. Tighten using Allen Wrench (L) provided**

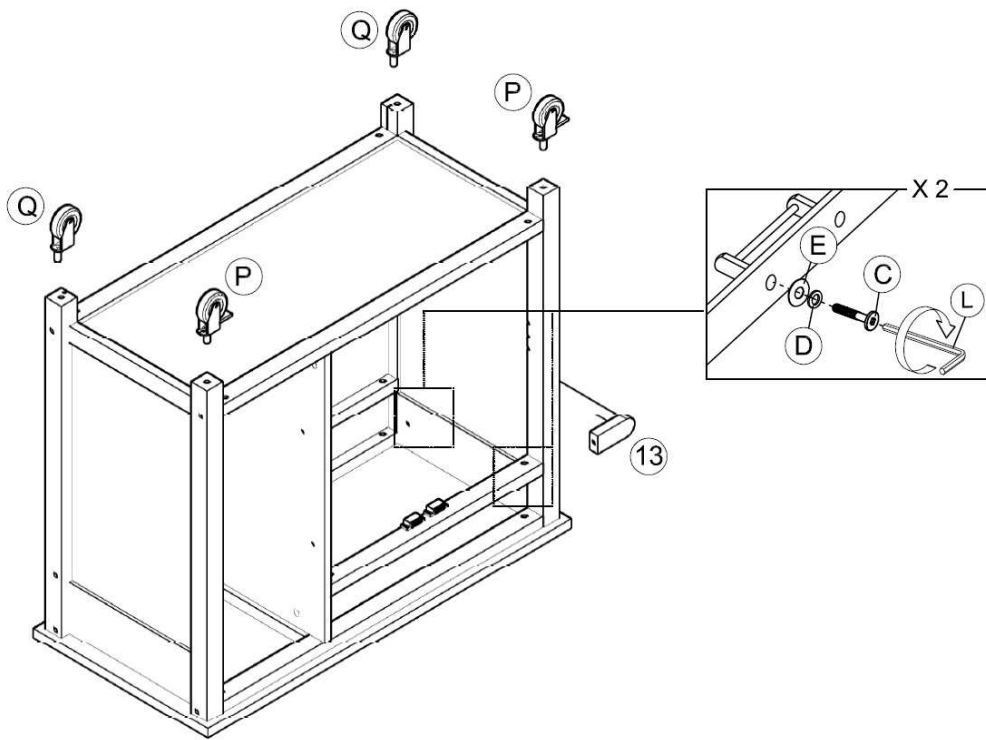

**Figure 5**

Attach Towel Bar **(13)** onto the unit as shown with Short Bolts (M6 X 40) **(C)**, Spring Washers **(D)** and Flat Washers **(E)**. Tighten using Allen Wrench **(L)** provided.

Attach Castors With Lock **(P)** and Castors Without Lock **(Q)** as shown.

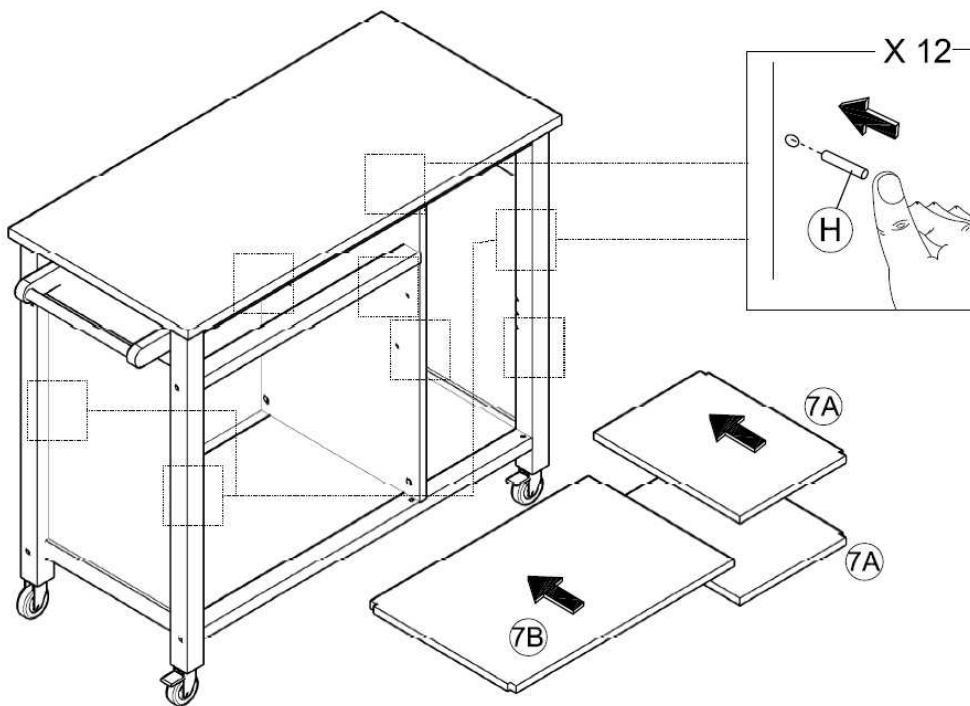

**Figure 6**

Insert Metal Pins **(H)** into the unit as shown.

Place Shelves **(R) (7A)** and Shelf **(L) (7B)** as shown.

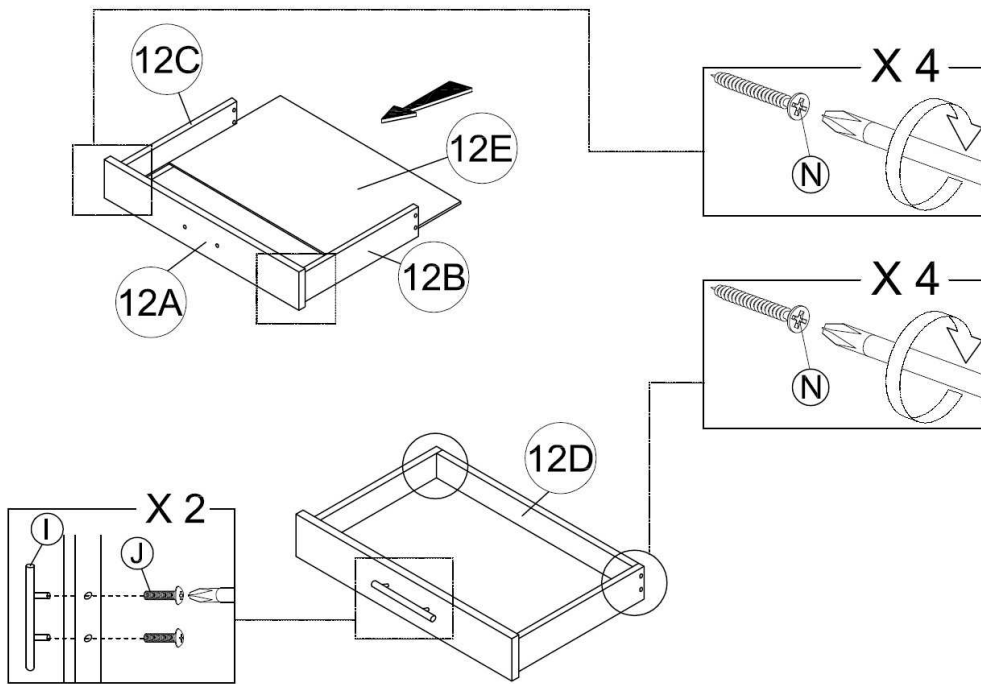

**Figure 7**

Attach Drawer Side Apron (R) (12B) and Drawer Side Apron (L) (12C) to Drawer Front (12A) as shown. Tighten using Wood Screw (N) with Screwdriver.

Slide Drawer Bottom Panel (12E) into assembled unit.

Place the Drawer Back Panel (12D) onto assembled unit. Tighten using Wood Screws (N) with Screwdriver.

Tighten Bar Handle (I) and Handle Screw (J) with Screwdriver.

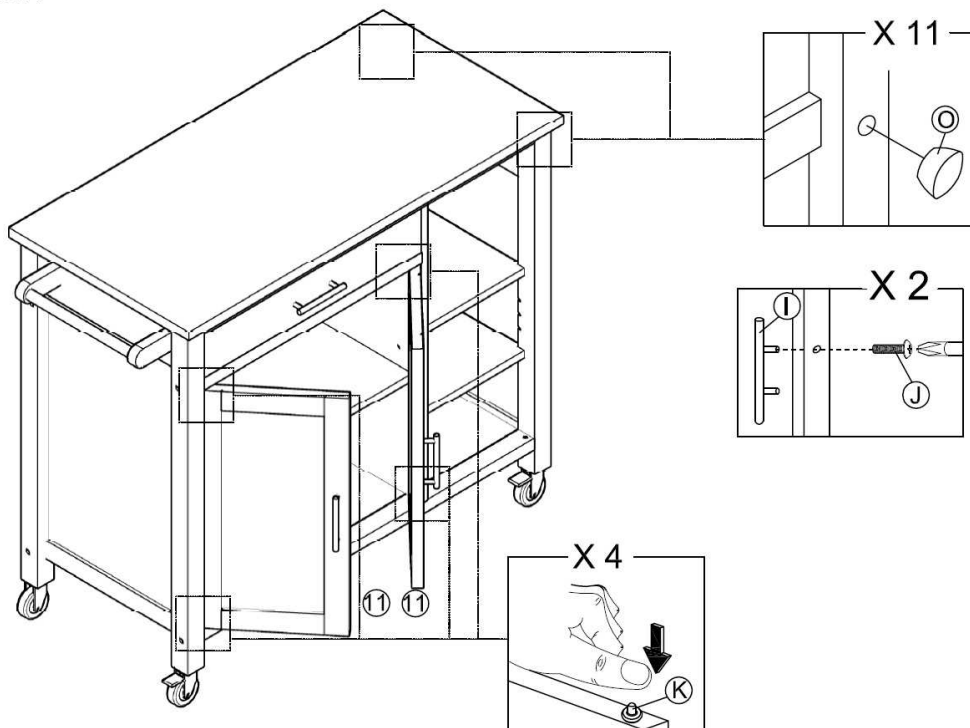

**Figure 8**

Insert Door Springs (K) into Doors (11) as shown. Place the doors onto the assembled unit by insert Door Spring into corresponding holes on Bottom Panel (10) then slide in the top Door Springs into the corresponding holes on Front Apron (9).

Attach Bar Handle (I) and Handle Screws (J) using Screwdriver.

Insert Wood Buttons (O) to cover all the holes for Bolts as shown.

Now your kitchen cart is ready to use



# Parts Replacement Form

## Customer Information

Name \_\_\_\_\_

Address \_\_\_\_\_

City/State/Zip Code \_\_\_\_\_

Phone Number \_\_\_\_\_

Please indicate where you purchased this item: Store/Website/Catalog

\_\_\_\_\_

Please indicate color/size/style number:

\_\_\_\_\_

Style No	Parts Letter	Parts Description	Quantity Needed
_____	_____	_____	_____
_____	_____	_____	_____
_____	_____	_____	_____

Please immediately examine this product carefully. Any request for missing parts or damage replacement must be received within 90 days of your receipt of the product. Replacement, if available, will be honored within this time frame. Parts will not be available for items arriving fully assembled. We do not recommend modifying product(s) and we are not responsible for any damages due to product modification(s). If damages or missing parts are not reported within 90 days of your receipt, we are under no obligation to provide parts or replacement merchandise. Please contact Southern Enterprises at 800-633-5096 or in Dallas 972-869-0111/ 9am – 4pm Mon-Fri Central time if you have product issues or email us at [service@seidal.com](mailto:service@seidal.com). Please ask for customer service representative for issues involving damages or replacement parts. Please ask for technical assistance representative for any issues with product and assembly/construction.

Please contact the retailer that you purchased from for returns.



**Southern**  
ENTERPRISES

Customer Service 1-800-633-5096  
[service@seidal.com](mailto:service@seidal.com)  
Southern Enterprises, Inc.  
600 Freeport Parkway, Suite 200  
Coppell, Texas 75019