

HO904600TX-BLACK/  
HO914600TX-WHITE/  
HO924600TX-ESPRESSO  
"LANGSTON" DESK  
Assembly Instruction



Southern  
ENTERPRISES

For assistance with assembly contact:  
Southern Enterprises Inc.  
Customer Service 1-800-633-5096  
[service@seidal.com](mailto:service@seidal.com)  
[www.seidal.com](http://www.seidal.com)

**Max top load 40 lb.**

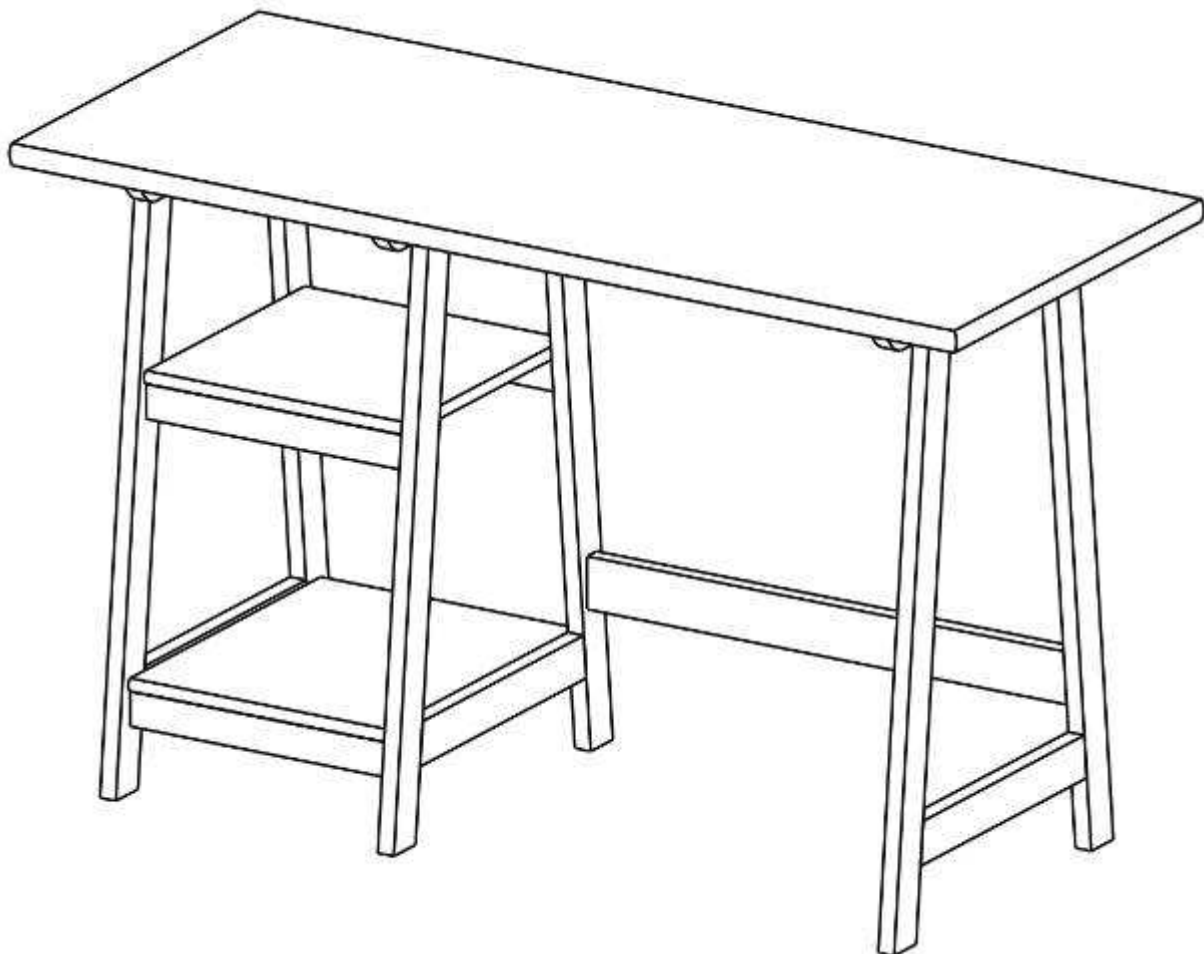

HO904600TX-BLACK



HO914600TX-WHITE/HO924600TX-ESPRESSO

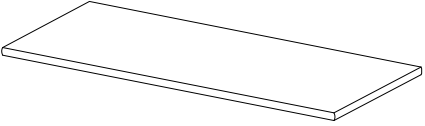
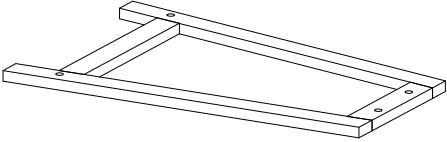
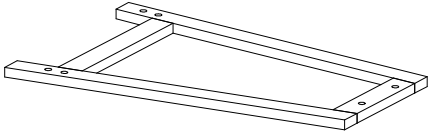
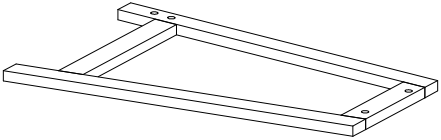
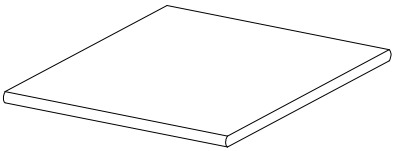
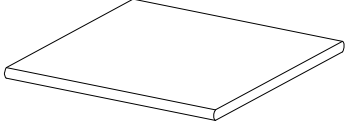
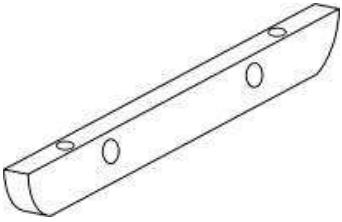
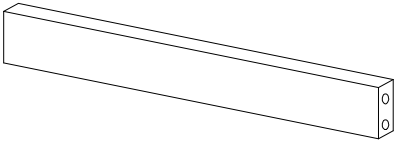
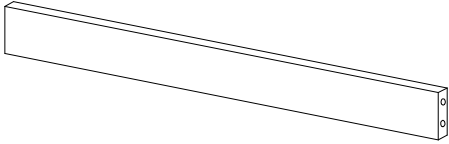

"LANGSTON" DESK

## Parts List

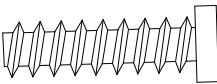
Please review all parts and hardware before disposing of any packaging.  
Call Customer Service if missing hardware. Do not return to store/retailer.  
Using a screw that is too long will cause damage. Before beginning assembly,  
separate each type of screw. Carefully study the screw diagrams below. You may  
receive extra hardware with your unit.

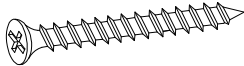
<p><b>A</b></p> <p>Quantity Of 1</p>  <p><b>Wood Top</b></p>	<p><b>B</b></p> <p>Quantity Of 1</p>  <p><b>Left Side Panel</b></p>	<p><b>C</b></p> <p>Quantity Of 1</p>  <p><b>Central panel</b></p>
<p><b>D</b></p> <p>Quantity Of 1</p>  <p><b>Right Side panel</b></p>	<p><b>E</b></p> <p>Quantity Of 1</p>  <p><b>Bottom Shelf</b></p>	<p><b>F</b></p> <p>Quantity Of 1</p>  <p><b>Top Shelf</b></p>
<p><b>G</b></p> <p>Quantity Of 3</p>  <p><b>Top Stretcher</b></p>	<p><b>H</b></p> <p>Quantity Of 4</p>  <p><b>Short Stretcher</b></p>	<p><b>I</b></p> <p>Quantity Of 1</p>  <p><b>Long Stretcher</b></p>

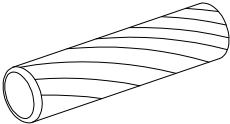
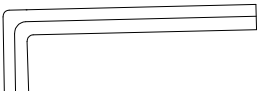
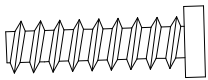
<p><b>1</b></p> <p style="text-align: center;">Quantity Of 10</p>  <p><b>Bolts 1/4"x 45mm</b></p>	<p><b>2</b></p> <p style="text-align: center;">Quantity Of 10</p>  <p><b>Barrel Nuts 1/4"</b></p>	<p><b>3</b></p> <p style="text-align: center;">Quantity Of 8</p>  <p><b>Screw 4 x 32mm</b></p>
--	--	---

<p><b>4</b></p> <p style="text-align: center;">Quantity Of 20</p>  <p><b>Dowel 8 x30 mm</b></p>	<p><b>5</b></p> <p style="text-align: center;">Quantity Of 1</p>  <p><b>Wrench 1/4"</b></p>	<p><b>6</b></p> <p style="text-align: center;">Quantity Of 6</p>  <p><b>Bolts 1/4" x 32mm</b></p> <hr/> <p><b>7</b></p> <p style="text-align: center;">Quantity Of 6</p>  <p><b>Bolts 1/4" x 25mm</b></p>
--	--	---

**Care and Cleaning Instructions:**  
 Before using, wipe with a clean, dry cloth.  
 Periodically apply furniture wax to renew the finish. Avoid rubbing or scratching the surface with rough or abrasive objects.

For replacement parts or questions, please call Customer Service at 1-800-633-5096. Do not return product to store. Please call manufacturer for assistance, questions or parts.

**Assembly Tool Required**  
**No.2 Phillips Screw Driver**



HO904600TX-BLACK/  
HO914600TX-WHITE/HO924600TX-ESPRESSO  
"LANGSTON" DESK  
Assembly Instruction

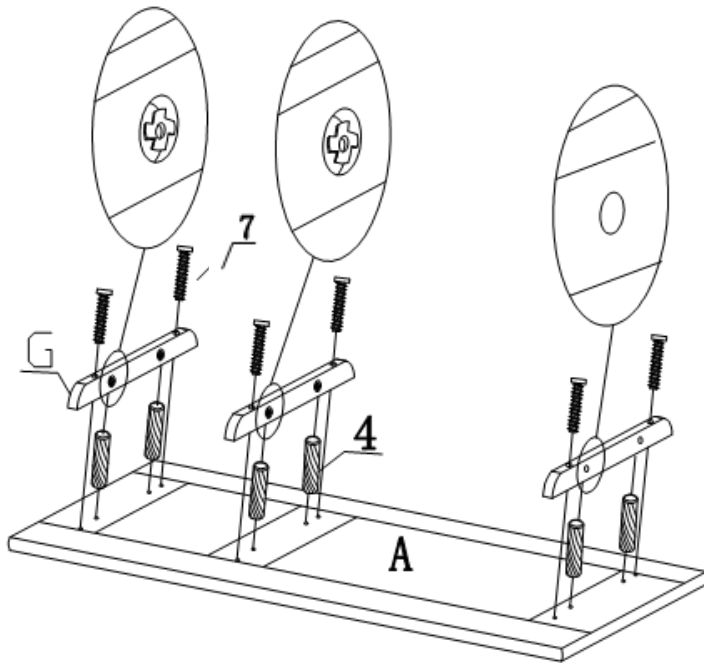

**Step 1:** Put all parts on a soft surface to prevent scratches.

Attach top stretcher (G) to wood top (A) by using bolts (7) and dowel (4) as shown.

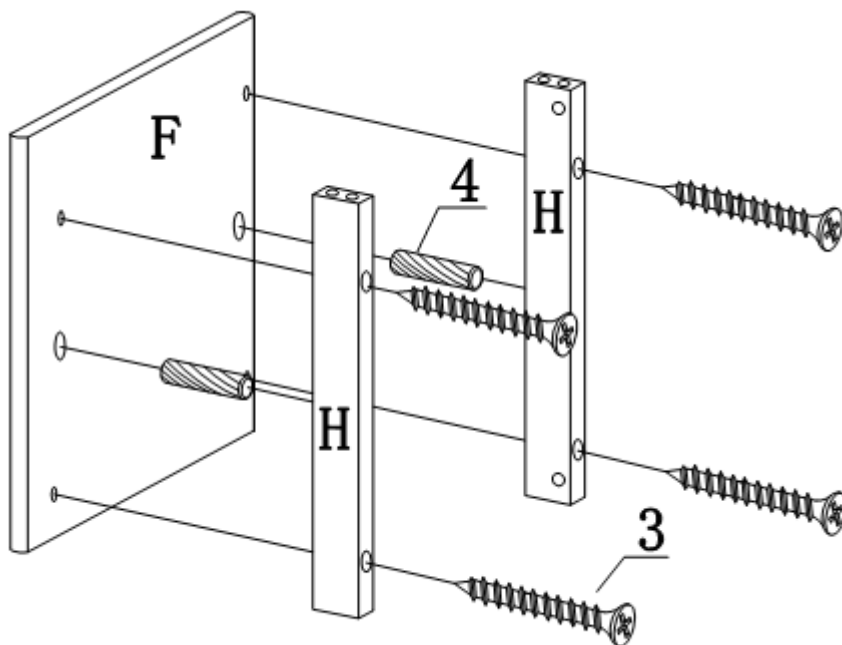

**Step 2:** Attach short stretcher (H) to top shelf (F) by using screw (3) and dowel (4) as shown.

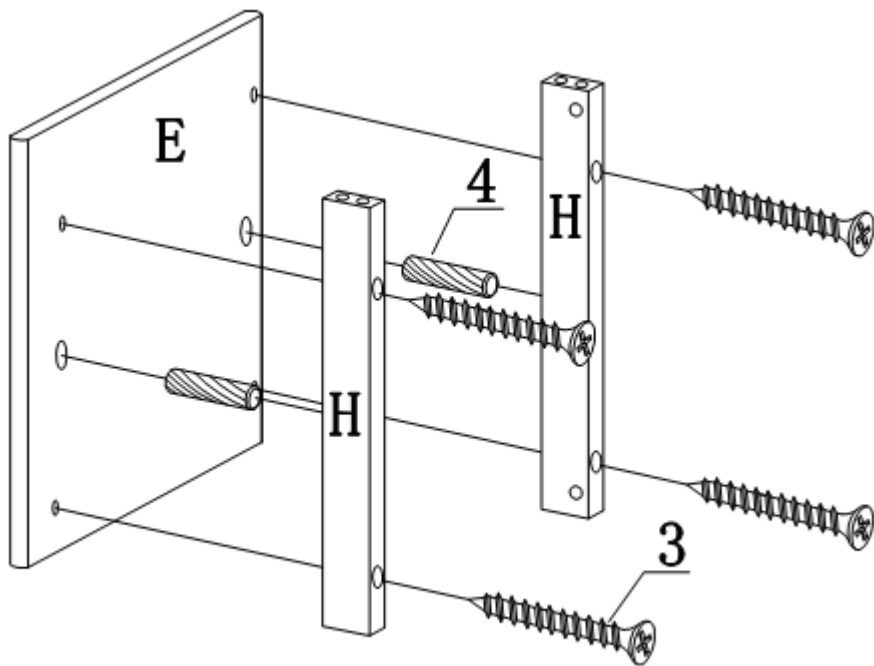

**Step 3:** Attach short stretcher (H) to bottom shelf (E) by using screw (3) and dowel (4) as shown.

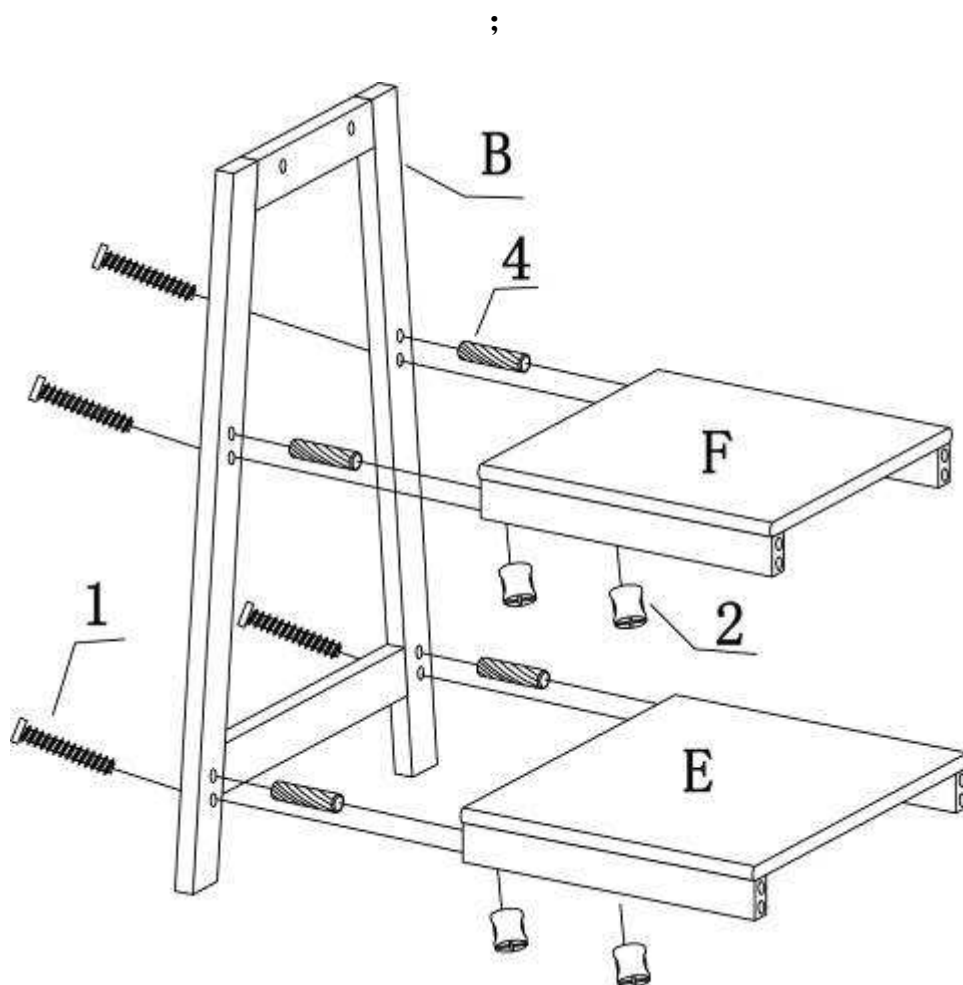

**Step 4:** Insert barrel nut (2) into short stretcher (H) and keep the hole of barrel nut (2) to be horizontal when assembly.

Then attach left side panel (B) to shelves (E) & (F) by using bolts (1), dowel (4) and barrel nut (2) as shown.

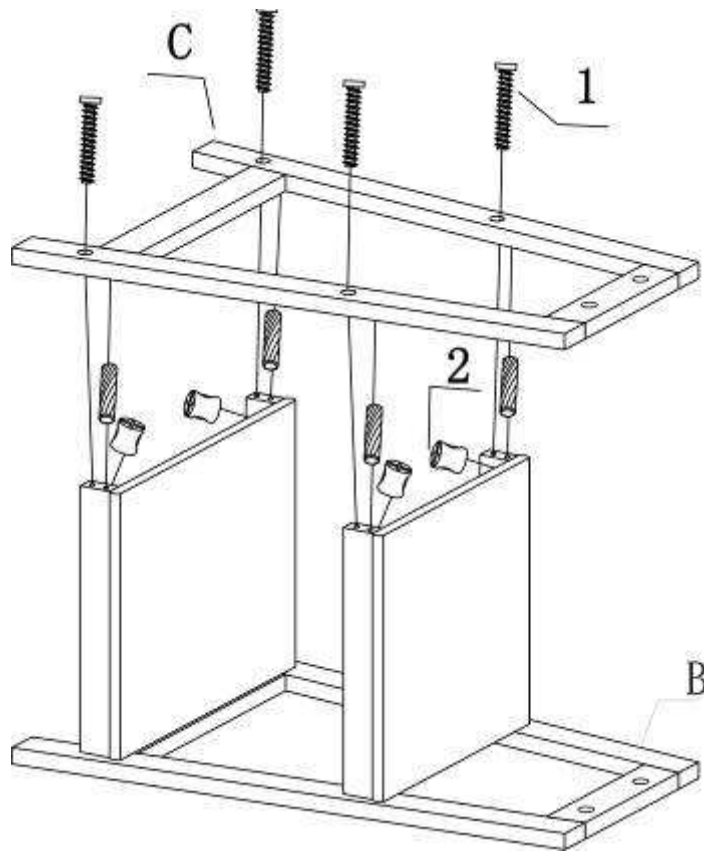

**Step 5:** Repeat same procedure as Step 4.

Attach central panel (C) to shelves (E) & (F) by using bolts (1), dowel (4) and barrel nut (2) as shown.

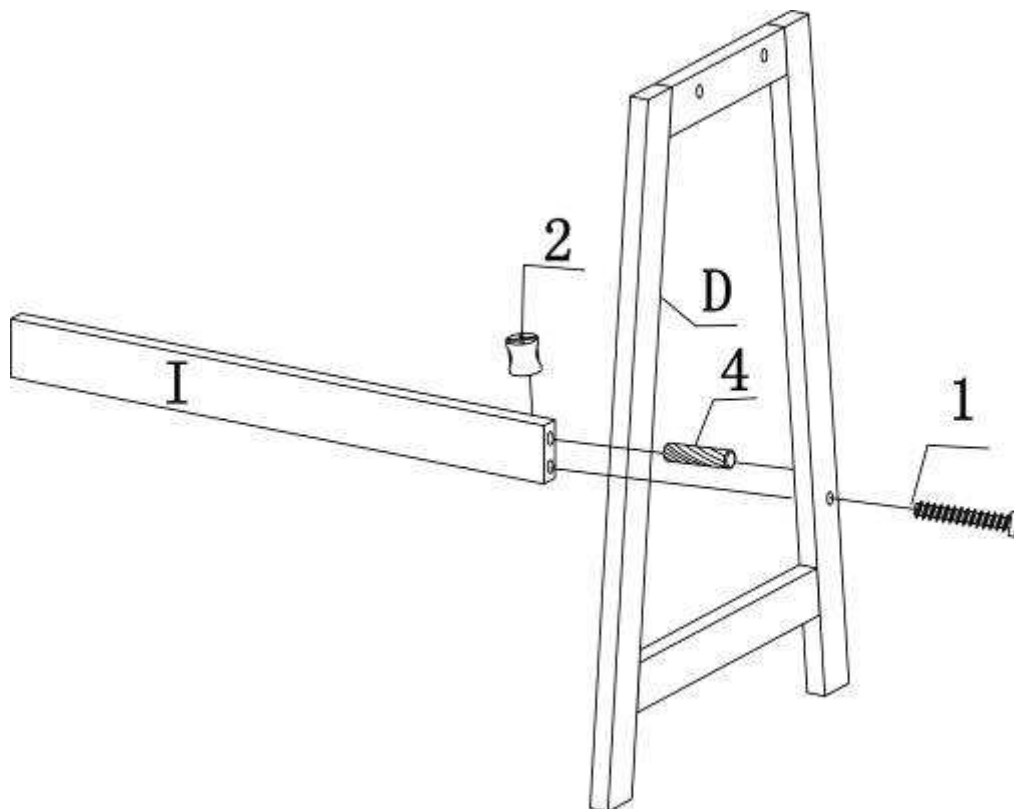

**Step 6:** Insert barrel nut (2) into long stretcher (I) and keep the hole of barrel nut (2) to be horizontal when assembly.

Attach long stretcher (I) to right side panel (D) by using bolt (1), dowel (4) and barrel nut (2) as shown.

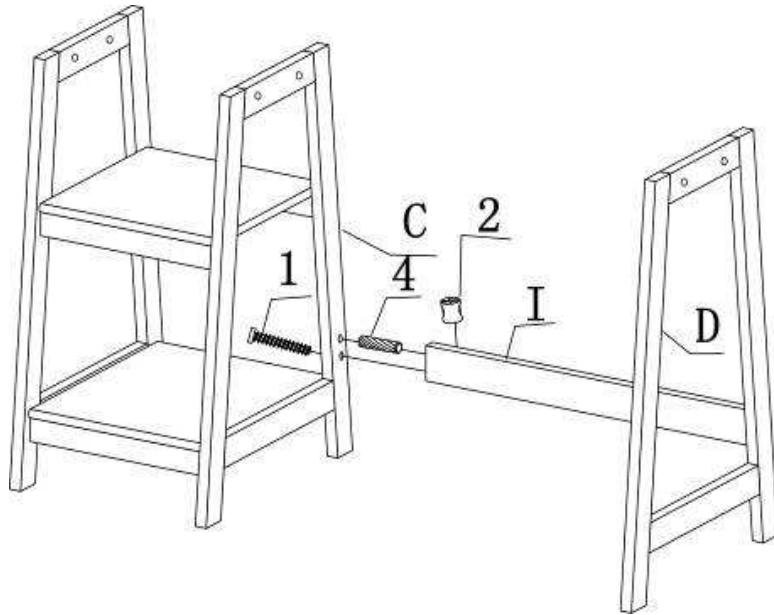

**Step 7:** Repeat same procedure as Step 6.

Attach long stretcher (I) to central panel (C) by using bolt (1), dowel (4) and barrel nut (2) as shown.

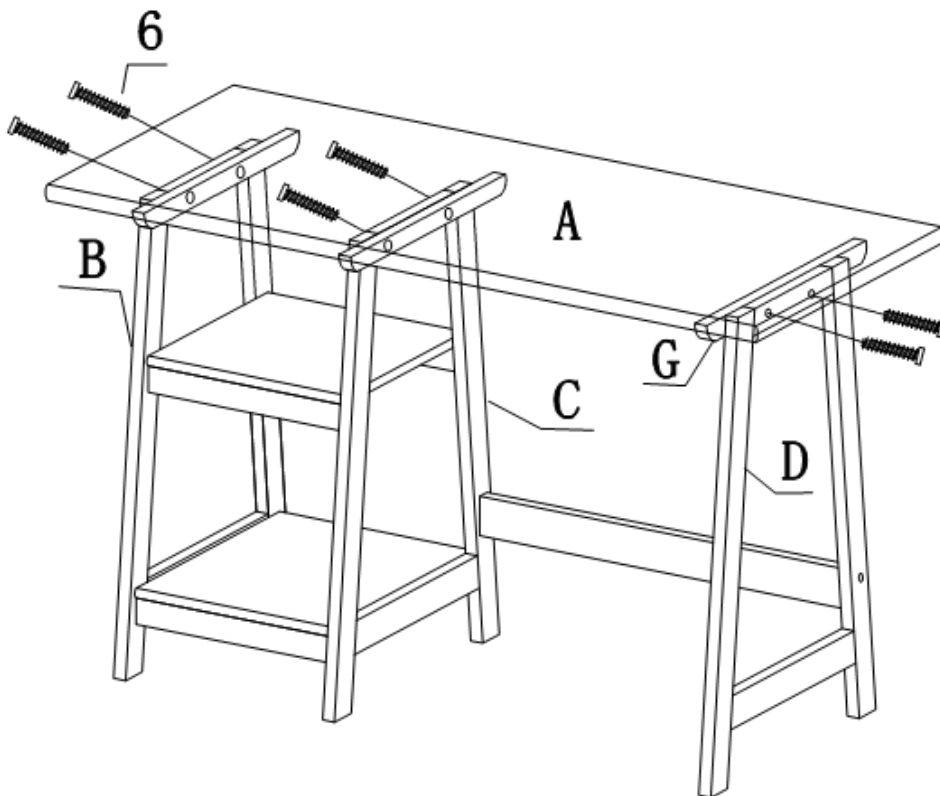

**Step 8:** Attach wood top (A) to panels (B), (C), (D) by using bolt (6) as shown.

Then your table is ready to use.

# Parts Replacement Form

## Customer Information

Name \_\_\_\_\_

Address \_\_\_\_\_

City/State/Zip Code \_\_\_\_\_

Phone Number \_\_\_\_\_

Please indicate where you purchased this item: Store/Website/Catalog  
\_\_\_\_\_

Please indicate color/size/style number:  
\_\_\_\_\_

Style No	Parts Letter	Parts Description	Quantity Needed
_____	_____	_____	_____
_____	_____	_____	_____
_____	_____	_____	_____

Please immediately examine this product carefully. Any request for missing parts or damage replacement must be received within 90 days of your receipt of the product. Replacement, if available, will be honored within this time frame. Parts will not be available for items arriving fully assembled. We do not recommend modifying product(s) and we are not responsible for any damages due to product modification(s). If damages or missing parts are not reported within 90 days of your receipt, we are under no obligation to provide parts or replacement merchandise.

Please contact Southern Enterprises at 800-633-5096 or in Dallas 972-869-0111/ 9am – 4pm Mon-Fri Central time if you have product issues or email us at [service@seidal.com](mailto:service@seidal.com). Please ask for customer service representative for issues involving damages or replacement parts. Please ask for technical assistance representative for any issues with product and assembly/construction.

Please contact the retailer that you purchased from for returns.



**Southern**  
ENTERPRISES

Customer Service

1-800-633-5096

[service@seidal.com](mailto:service@seidal.com)

Southern Enterprises, Inc.

600 Freeport Parkway, Suite 200