

BC282500 TX
CULTER STORAGE
BENCH - BLACK
ASSEMBLY INSTRUCTIONS

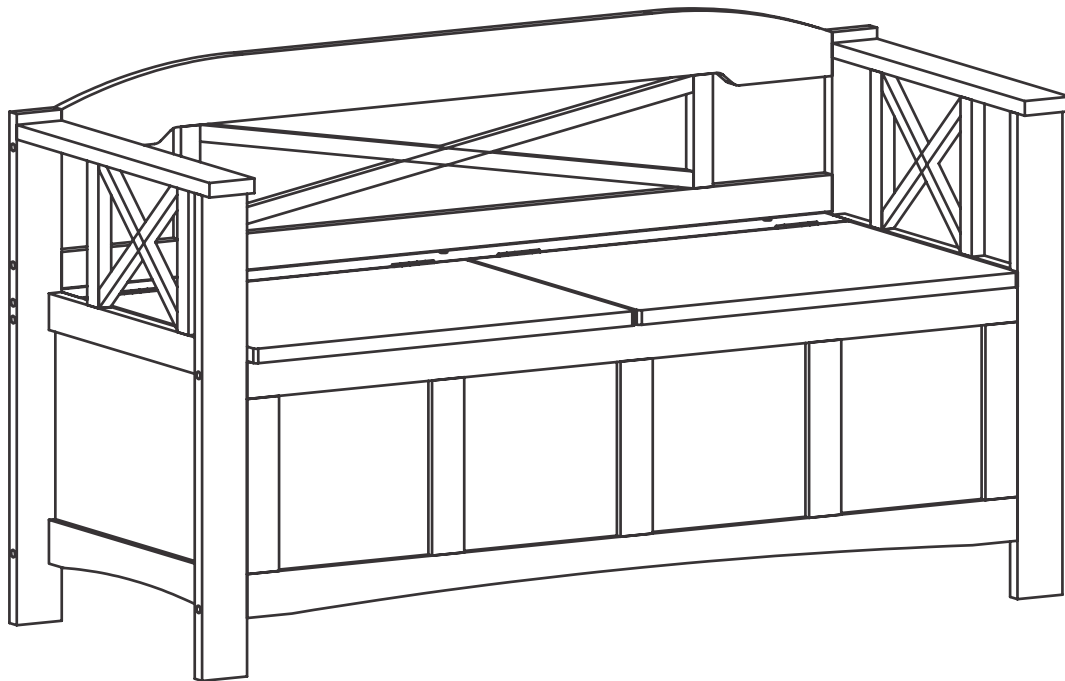

For assistance with assembly, contact:
Southern Enterprises Inc.
Customer Service 1-800-633-5096
service@seidal.com
www.seidal.com



BC282500 TX

CULTER STORAGE BENCH - BLACK

Parts List







Please review all parts and hardware before disposing of any packaging.

Call Customer Service if missing hardware. Do not return to store/retailer.

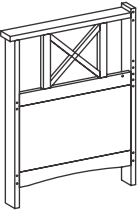
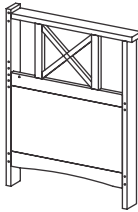
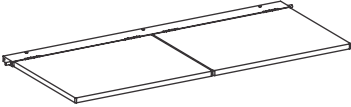
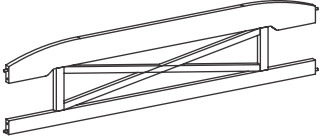
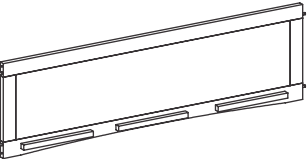
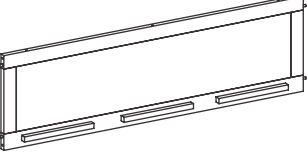
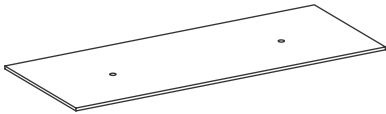
Using a screw that is too long will cause damage.

Before beginning assembly, separate each type of screw.

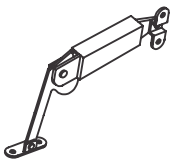
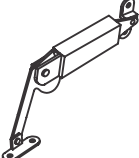
Carefully study the screw diagrams below. You may receive extra hardware with your unit.

<p>A</p>  <p>Quantity Of 1</p> <p>Left side frame</p>	<p>B</p>  <p>Quantity Of 1</p> <p>Right side frame</p>	<p>C</p>  <p>Quantity Of 1</p> <p>Top</p>	<p>D</p>  <p>Quantity Of 1</p> <p>Back rest</p>
<p>E</p>  <p>Quantity Of 1</p> <p>Front panel</p>	<p>F</p>  <p>Quantity Of 1</p> <p>Back panel</p>	<p>G</p>  <p>Quantity Of 1</p> <p>Bottom shelf</p>	
<p>1</p>  <p>Quantity Of 14</p> <p>Bolt M6x80mm</p>	<p>2</p>  <p>Quantity Of 3</p> <p>Bolt M6x38mm</p>	<p>3</p>  <p>Quantity Of 8</p> <p>Screw 3x15mm</p>	
<p>4</p>  <p>Quantity Of 1</p> <p>Left hinge</p>	<p>5</p>  <p>Quantity Of 1</p> <p>Right hinge</p>	<p>6</p>  <p>Quantity Of 14</p> <p>WOOD PLUGS</p>	

Care and Cleaning Instructions:

Before using, wipe with a clean, dry cloth. Periodically apply furniture wax to renew the finish. Avoid rubbing or scratching the surface with rough or abrasive objects.

For replacement parts or questions, please call Customer Service at 1-800-633-5096. Do not return product to store. Please call manufacturer for assistance, questions or parts.

Assembly Tool Required
Allen Key 4mm



Assembly Tool Required
No.2 Phillips Screw Driver

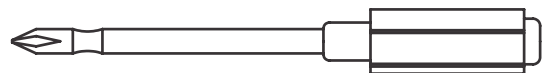

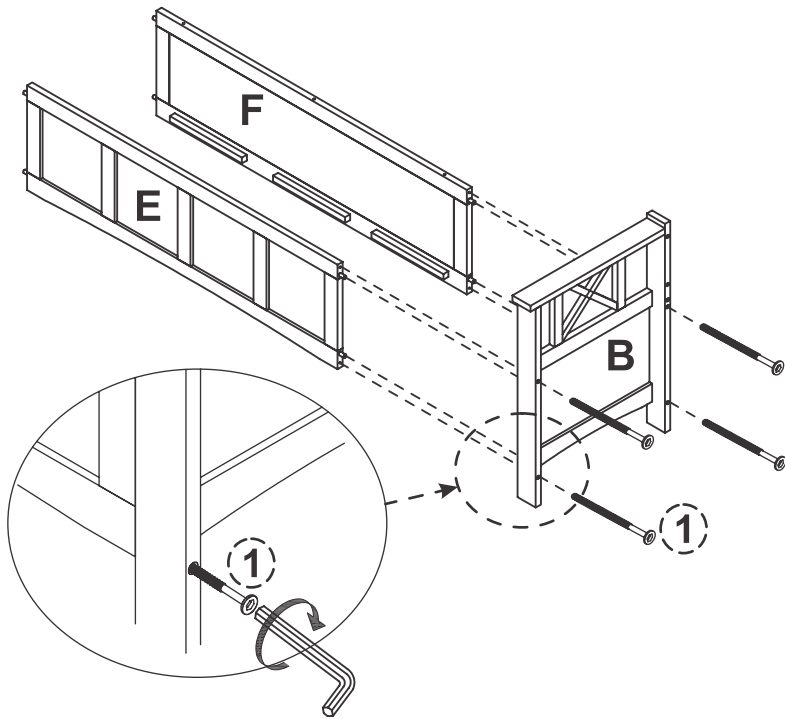

Step 1:

Attach front and back panel (E & F) to right side frame (B) by using bolt (1) and allen key as shown.

1		Quantity Of 4
BOLT M6x80mm		

	Quantity Of 1
Allen Key 4 mm	

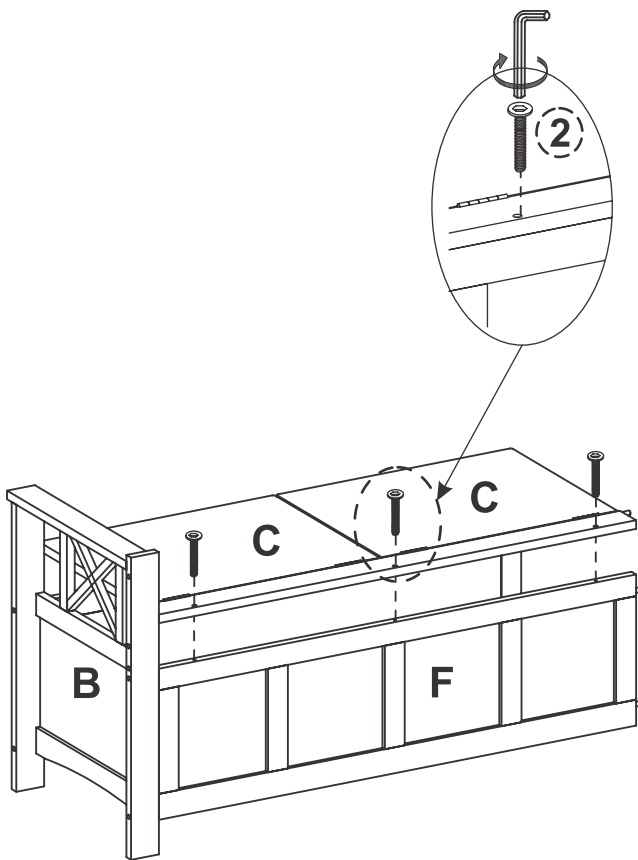

Step 2:

Attach top (C) to back panel (F) right side frame (B) by using bolt (2) and allen key as shown.

2		Quantity Of 3
BOLT M6x38mm		

	Quantity Of 1
Allen Key 4 mm	



Customer Service
 1-800-633-5096
service@seidal.com
 Southern Enterprises, Inc.
 600 Freeport Parkway Suite: 200

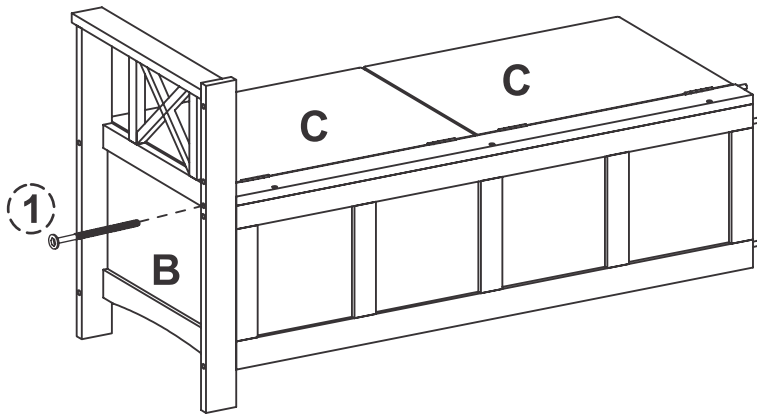

Step 3:

Attach right side frame (B) with top (C) by using bolt (1) and allen key.



Quantity
Of 1

BOLT M6x80mm



Quantity
Of 1

Allen Key 4 mm

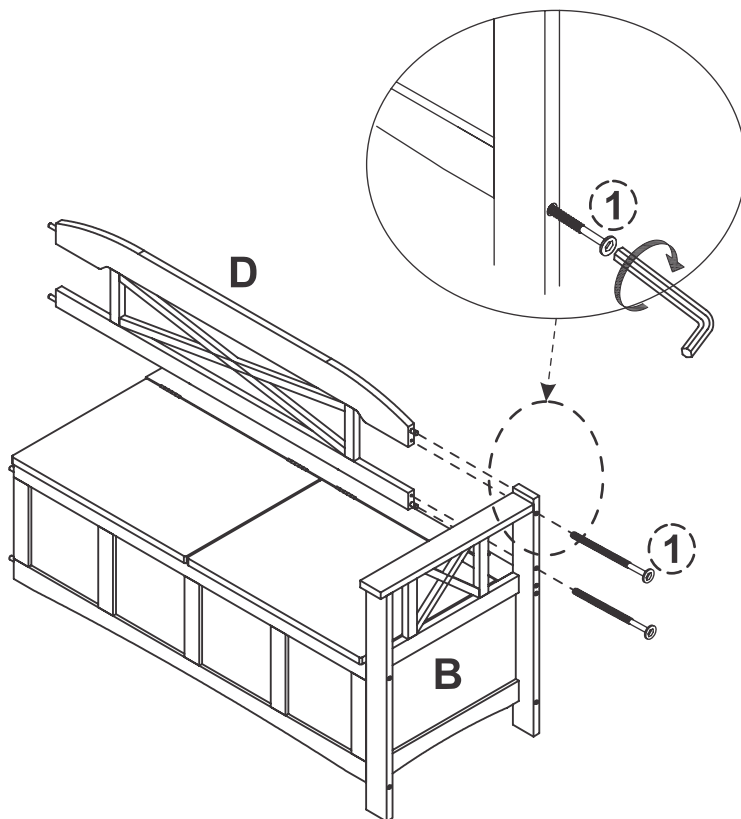

Step 4:

Attach backrest (D) to right side frame (B) by using bolt (1) and allen key to tight as shown.



Quantity
Of 2

BOLT M6x80mm



Quantity
Of 1

Allen Key 4 mm



Customer Service
1-800-633-5096
service@seidal.com
Southern Enterprises, Inc.
600 Freeport Parkway Suite: 200

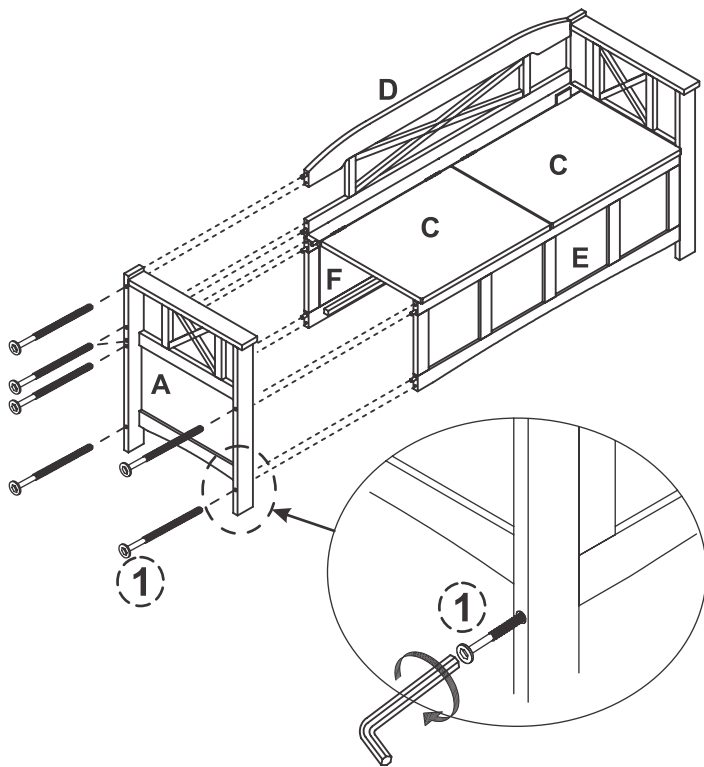

Step 5:

Attach left side frame (A) to the rest of assembled (C, D, E, F) by using long bolt (1) and allen key as shown.

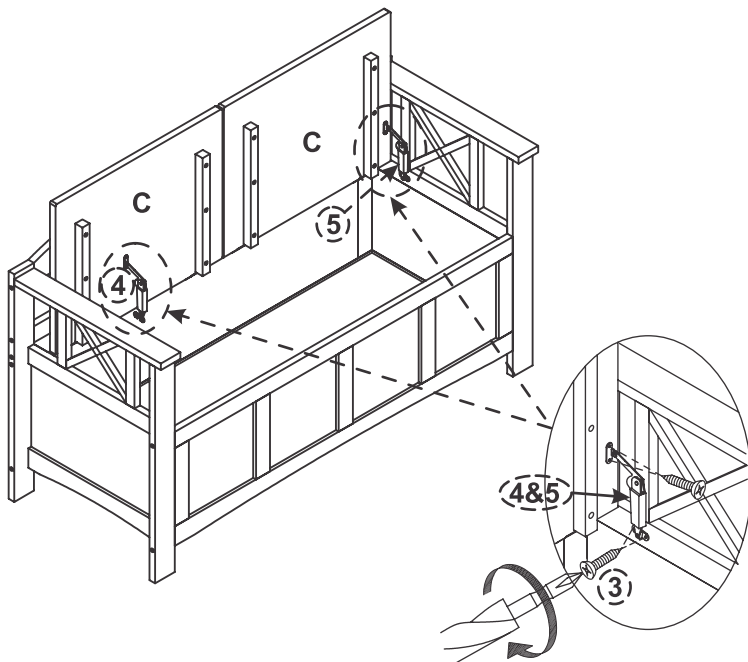
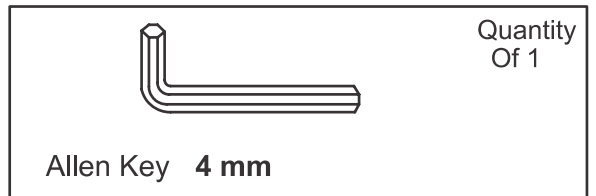
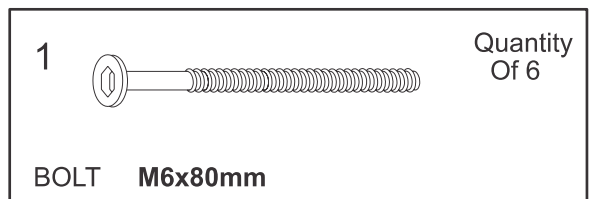

Step 6:

Attach left and right hinge (4, 5) to the top (C) by using screw (3) and tighten by hexhead screwdriver as shown.

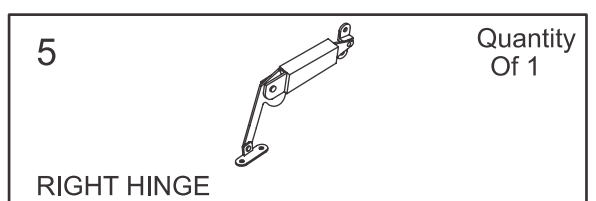
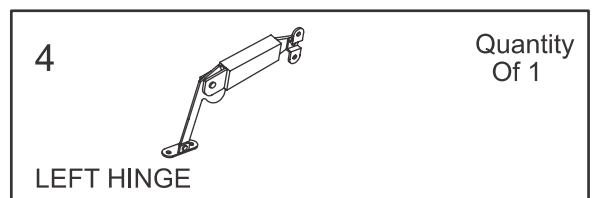
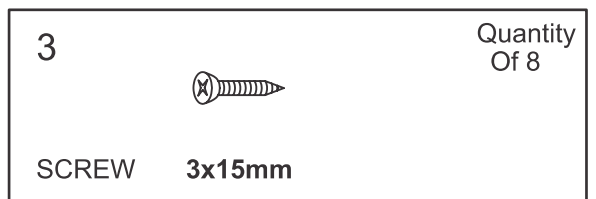

Customer Service
 1-800-633-5096
service@seidal.com
 Southern Enterprises, Inc.
 600 Freeport Parkway Suite: 200

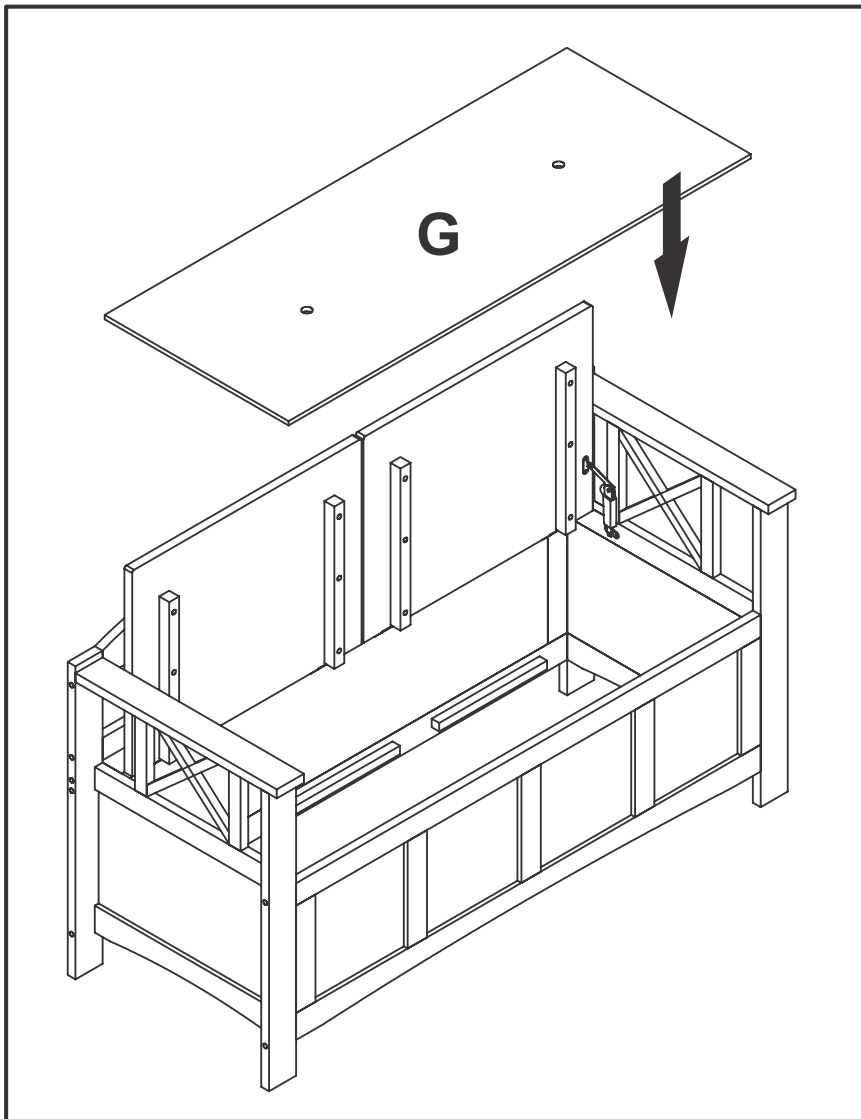

Step 7:
Attach bottom panel to the bench.

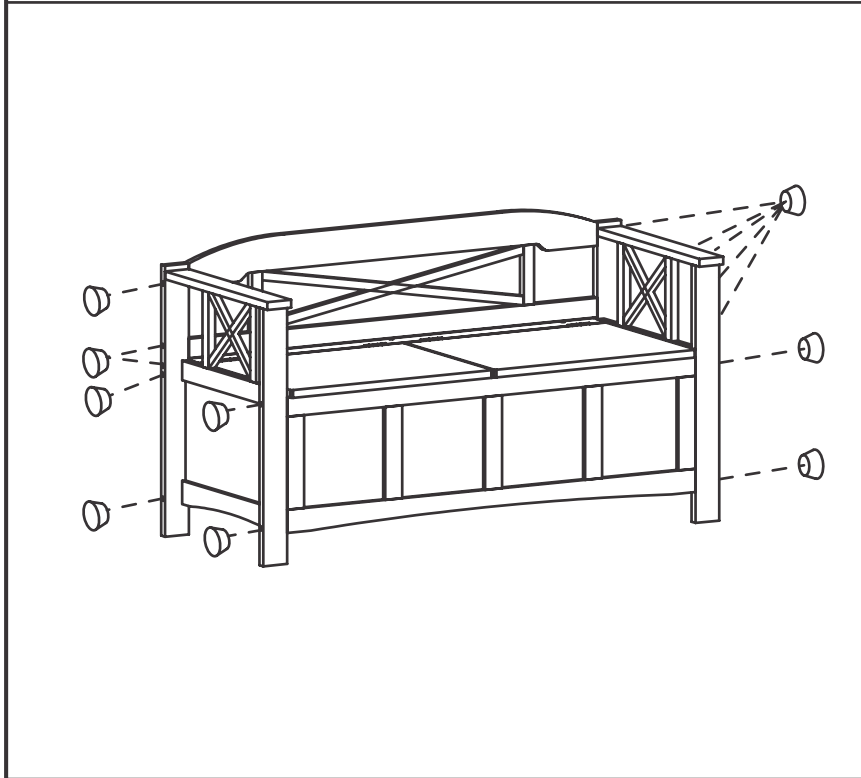

Step 8:
Use Wood plug (6) to cover the hole for both side as shown.

6		Quantity Of 14
WOOD PLUGS		



Customer Service
1-800-633-5096
service@seidal.com
Southern Enterprises, Inc.
600 Freeport Parkway Suite: 200

Parts Replacement From

Customer Information _____

Name _____

Address _____

City/State/Zip Code _____

Phone Number _____

Please indicate where you purchased this item: Store/Website/Catalog

Please indicate color/size/style number:

Style No	Parts Letter	Parts Description	Quantity Needed
_____	_____	_____	_____
_____	_____	_____	_____

Please immediately examine this product carefully. Any request for missing parts or damage replacement must be received within 90 days of your receipt of the product. Replacement, if available, will be honored within this time frame. Parts will not be available for items arriving fully assembled. We do not recommend modifying product(s) and we are not responsible for any damages due to product modification(s). If damages or missing parts are not reported within 90 days of your receipt, we are under no obligation to provide parts or replacement merchandise.

Please contact Southern Enterprises at 800-633-5096 or in Dallas 972-869-0111/ 9am – 4pm Mon-Fri Central time if you have product issues or email us at service@seidal.com. Please ask for customer service representative for issues involving damages or replacement parts. Please ask for technical assistance representative for any issues with product and assembly/construction

Please contact the retailer that you purchased from for returns.



Customer Service
1-800-633-5096
service@seidal.com
Southern Enterprises, Inc.
600 Freeport Parkway Suite: 200