

CK8773R0BP

METAL SOFA TABLE-BLACK

Assembly Instructions



For assistance with assembly contact:
Southern Enterprises Inc.
Customer Service 1-800-633-5096
service@seidal.com
www.seidal.com

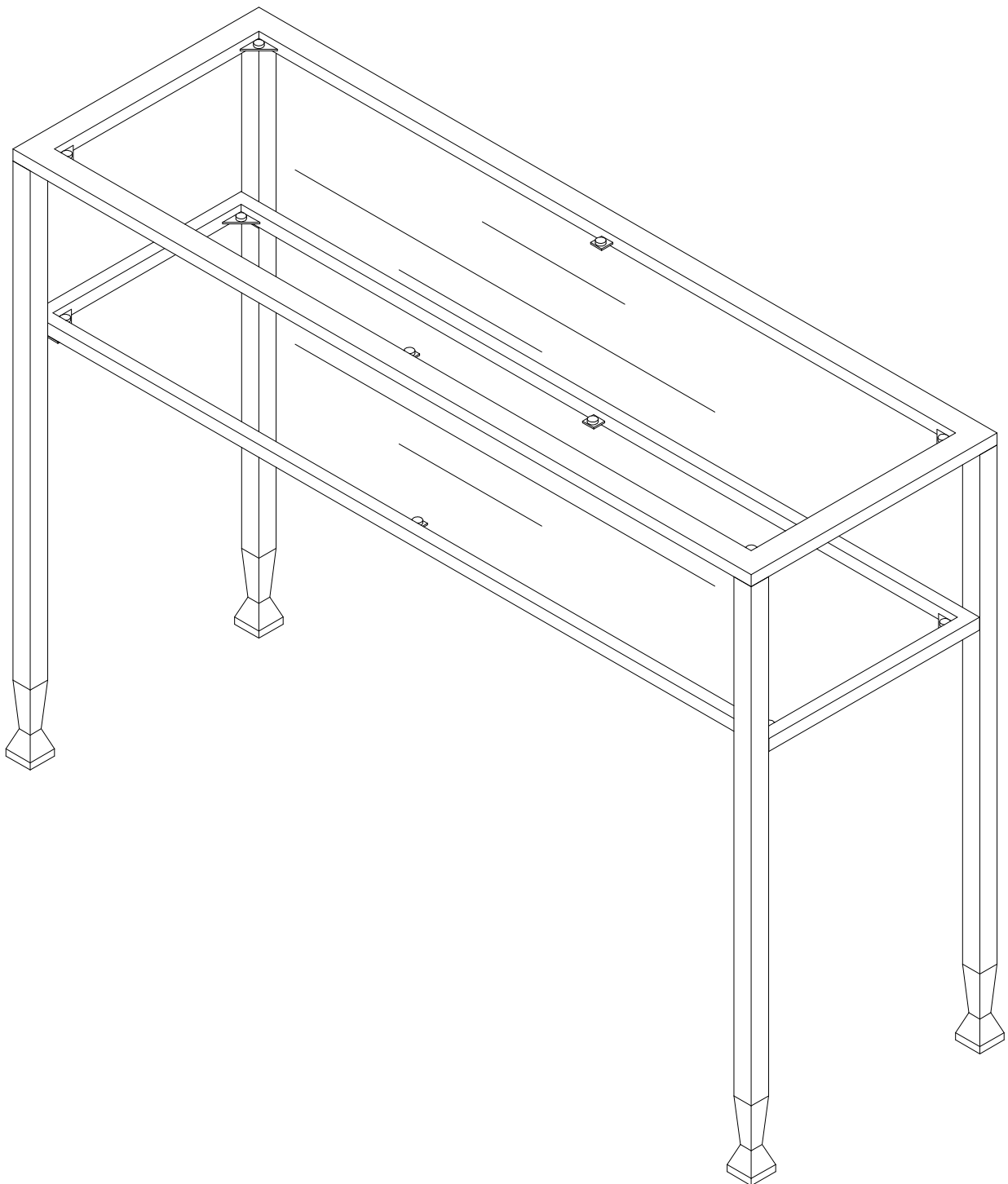

METAL SOFA TABLE-BLACK

Parts List

Please review all parts and hardware before disposing of any packaging. Call Customer Service if missing hardware. Do not return to store/retailer. Screws shown in actual size. Using a screw that is too long will cause damage. Before beginning assembly, separate each type of screw. Carefully study the screw diagrams below. You may receive extra hardware with your unit.

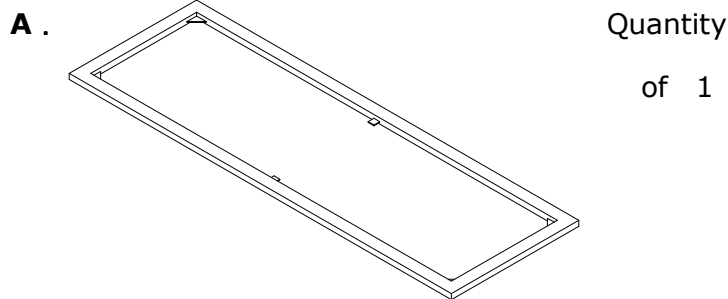

Quantity
of 1

TOP FRAME 42"x14"

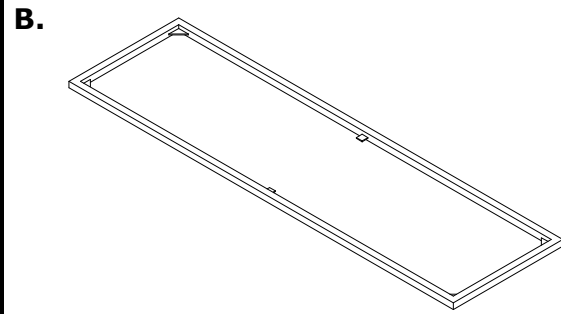

Quantity
of 1

SHELF FRAME 42"x12"

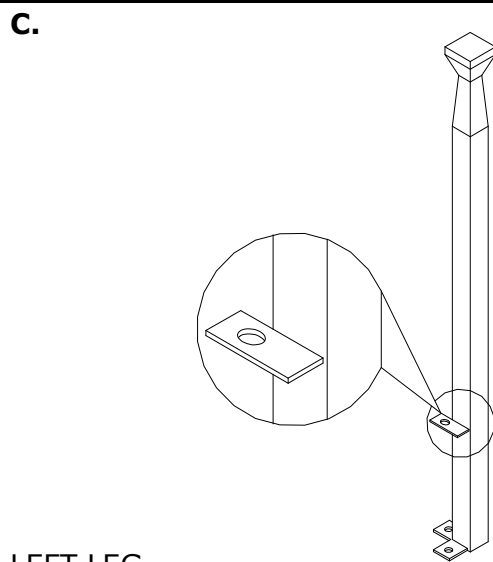

Quantity
of 2

LEFT LEG

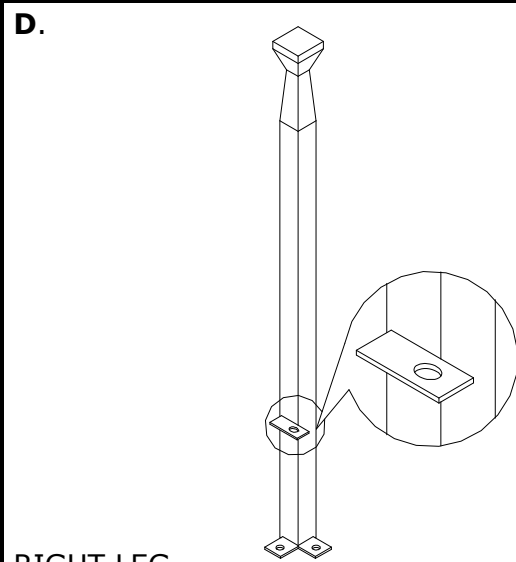

Quantity
of 2

RIGHT LEG

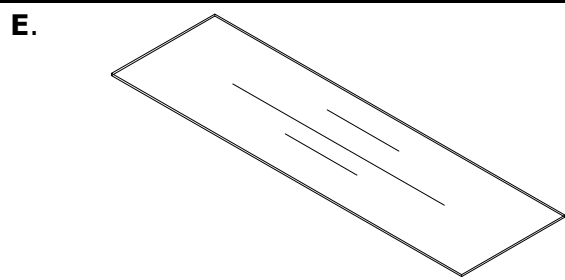

Quantity
of 1

TOP GLASS PANEL 39.5"x11.53"

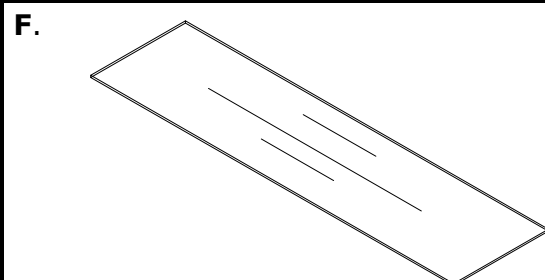

Quantity
of 1

GLASS Panel 40.63"x10.63"



Quantity
of 12

Bolt 1/4"*1/2"L



Quantity
of 12

GLASS PAD

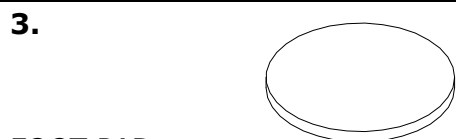

Quantity
of 4

FOOT PAD

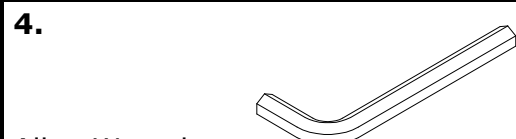

Quantity
of 1

Allen Wrench

Care and Cleaning Instructions:

Before using, wipe with a clean, dry cloth. Avoid rubbing or scratching the surface with rough or abrasive objects.

For replacement parts or questions, please Call Customer Service at 1-800-633-5096 Do not return product to store, please call Manufacturer for assistance, questions or Parts.

METAL SOFA TABLE-BLACK

Assembly Instructions

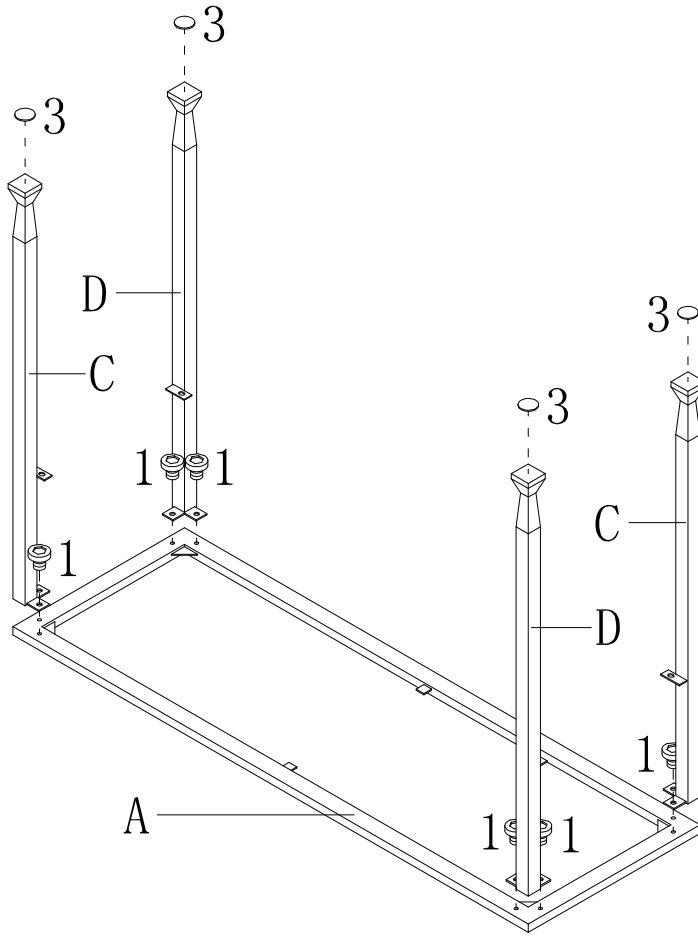

Figure 1

Assembly Instructions:

Unpack and lay parts on clean, padded surface like carpet or blanket. Check that you have all parts indicated on the front page.

Attach 4pcs Foot pads(3) on the ends of 4pcs Legs(C & D).

Insert 8pcs Bolts(1) through holes on Legs(C & D) to attach the 4pcs Legs(C & D) to Top Frame(A).

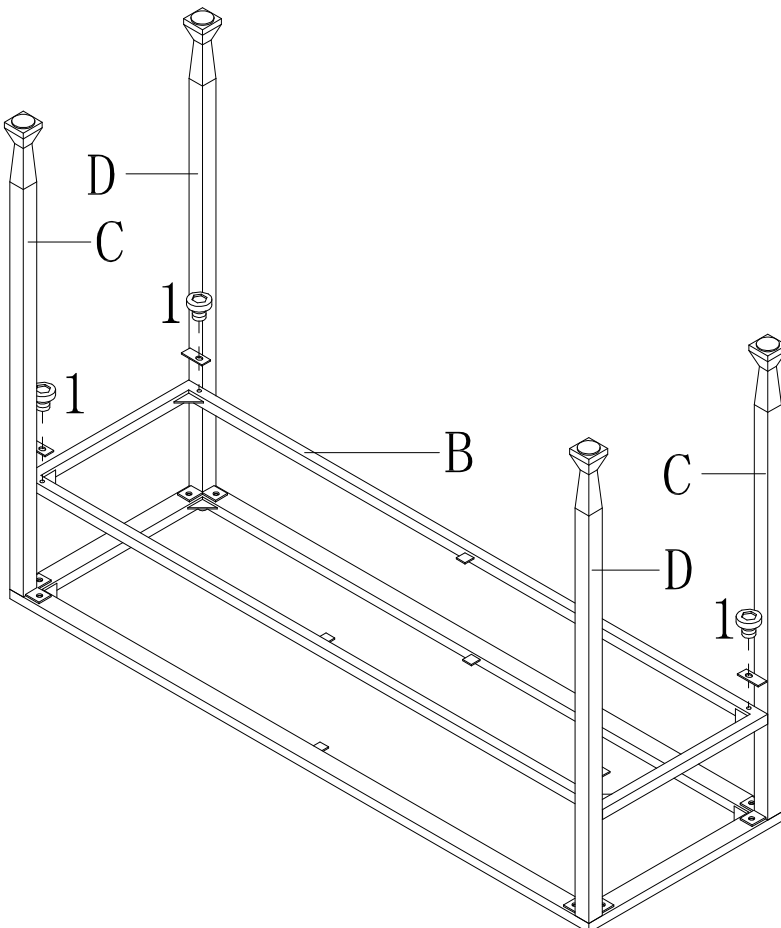

Figure 2

Insert 4pcs Bolts(1) through holes on Legs(C & D) to attach the 1pc Shelf Frame(B) to 4pcs Legs(C&D).

METAL SOFA TABLE-BLACK

Assembly Instructions

Add 12pcs Glass pads(2) onto 3pcs Frames(A & B).

Put Top Glass Panel(E) onto the Top Frame(A).

Put Glass panel(F) onto Shelf Frame(B).

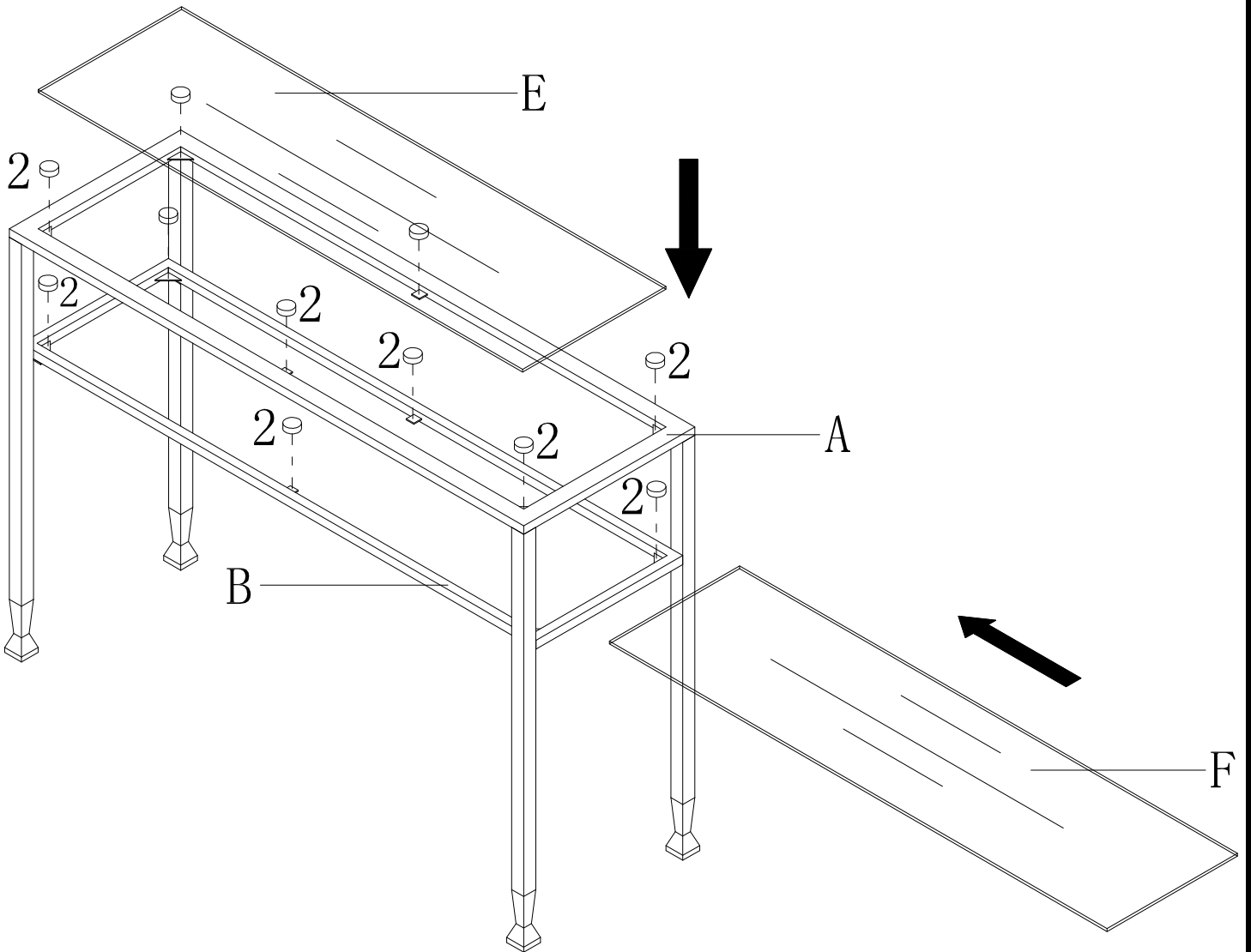

Figure 3



Customer Service 1-800-633-5096
service@seidal.com
Southern Enterprises Inc.
600 Freeport Parkway, Suite 200
Coppell, Texas, 75019

CK8773R0BP - Parts Replacement Form

Customer Information

Name _____

Address _____

City/State/Zip Code _____

Phone Number _____

Please indicate where you purchased this item: Store/Website/Catalog

Please indicate color/size/style number:

Style No	Parts Letter	Parts Description	Quantity Needed
_____	_____	_____	_____
_____	_____	_____	_____
_____	_____	_____	_____

Missing or damaged hardware and/or parts will be replaced free of charge. We do not sell parts. Southern Enterprises Inc. will provide replacement parts for only those items purchased within the last 9 months. If this product has not been purchased from our retail affiliates (within 9 months), we are under no obligation to provide parts or replacement merchandise. Parts will not be available for items arriving fully assembled.

Parts will be sent if available from SEI

Please contact Southern Enterprises at 800-633-5096 or in Dallas (972) 869-0111/ 9am – 4pm Mon-Fri Central time if you have product issues with your purchase. Please ask for a customer service representative for issues involving damages or replacement parts. Please ask for a technical assistance representative for any issues with product assembly and product construction.

Please contact the retailer that you purchased from for returns.

We'd love to hear from you! Email us photos of our products in your home at sei@seidal.com and we might feature it on our site or use it to model one of our inspirational photos.