

KA980300TX

"CELTIC" BISTRO WINE RACK

Assembly Instructions



For assistance with assembly contact:
Southern Enterprises Inc.
Customer Service 1-800-633-5096
service@seidal.com
www.seidal.com

PO# 12503

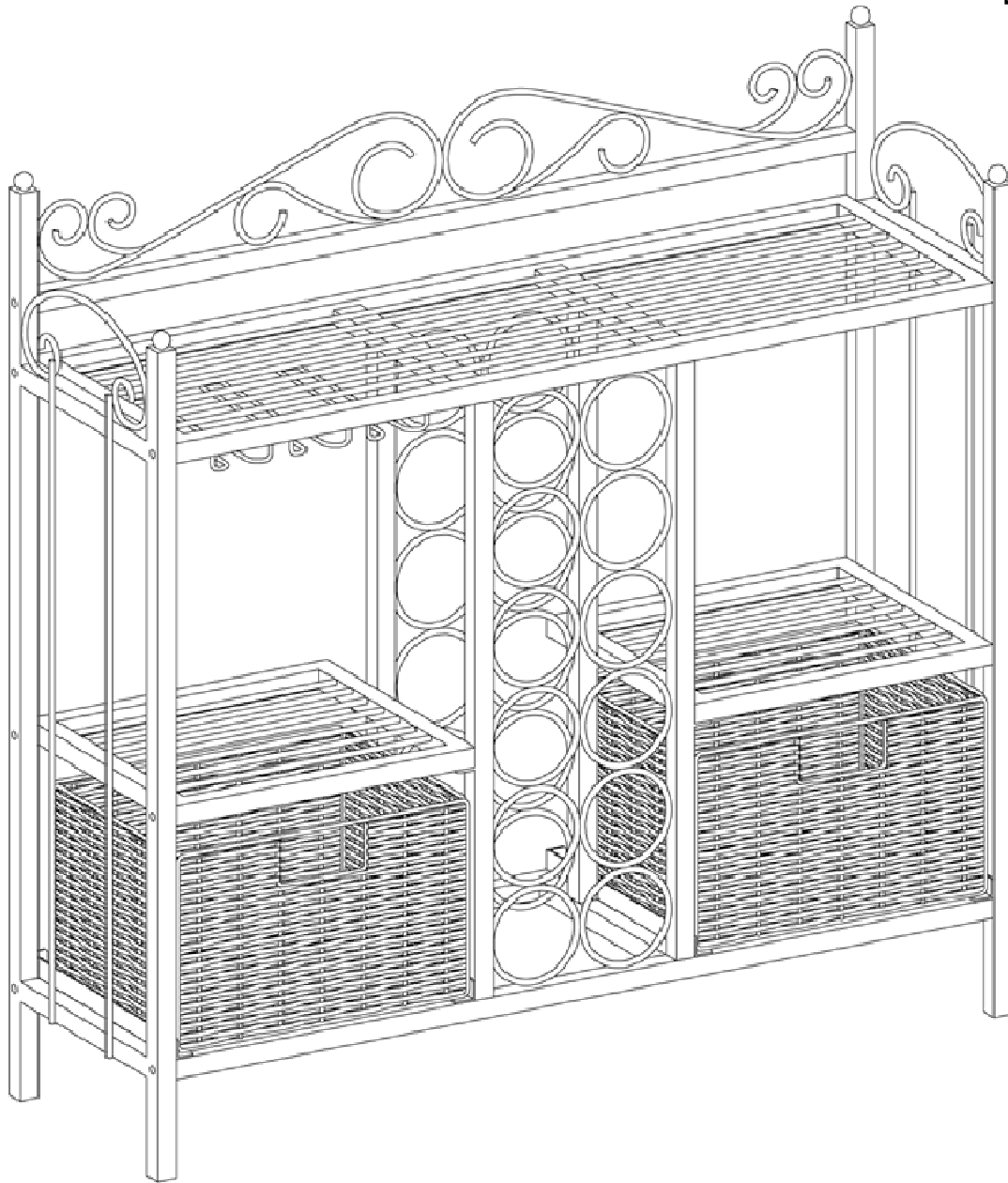

"CELTIC" BISTRO WINE RACK

Parts List

Please review all parts and hardware before disposing of any packaging. Call Customer Service if missing hardware. Do not return to store/retailer. Using a screw that is too long will cause damage. Before beginning assembly, separate each type of screw. Carefully study the screw diagrams below. You may receive extra hardware with your unit.

A. Left side frame Quantity
 of 1

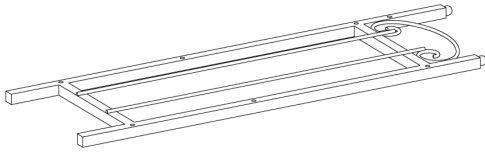

B. Right side frame Quantity
 of 1

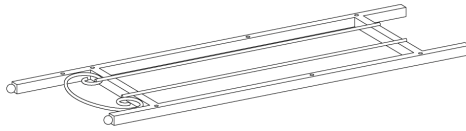

C. Bottom frame Quantity
 of 1

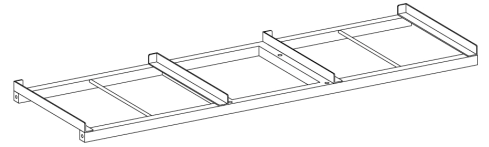

D. Top shelf frame Quantity
 of 1

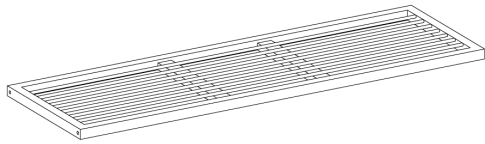

E. Back decorative panel Quantity
 of 1

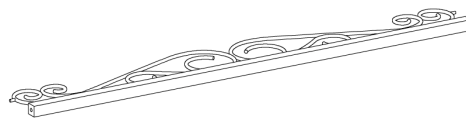

F. Wine frame Quantity
 of 2

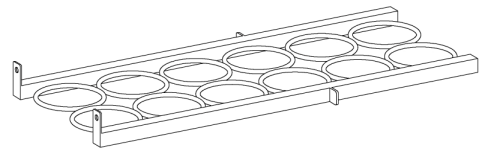

G. Small shelf frame Quantity
 of 2

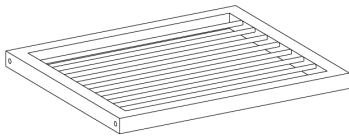

H. Cup holder Quantity
 of 3

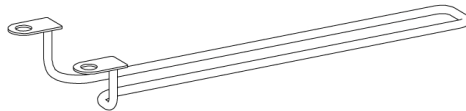

J. Wicker basket Quantity
 of 2

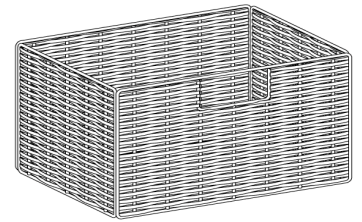

K. Basket bottom panel Quantity
 of 2

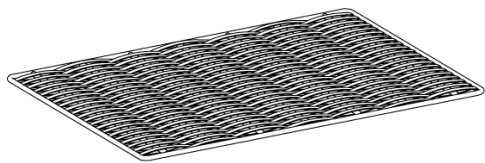

1. Long Bolt Quantity
 of 14

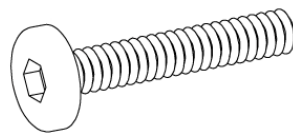

1/4"*1"L

2. Short Bolt Quantity
 of 4

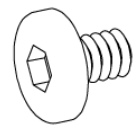

1/4"*1/2"L

3. Allen Wrench Quantity
 of 1

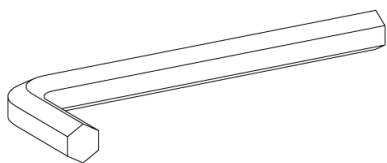

4. Long Bolt Quantity
 of 4

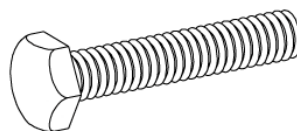

M5*1"L

5. Short Bolt Quantity
 of 6



M5"*3/8"L

6. Allen Wrench Quantity
 of 1

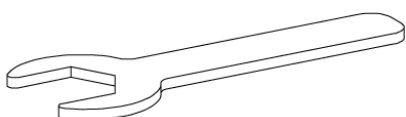

Care and Cleaning Instructions:

Before using , wipe with a clean , dry cloth. Avoid rubbing or scratching the surface with rough or abrasive objects.

For replacement parts or questions, please Call Customer Service at 1-800-633-5096
Do not return product to store, please call Manufacturer for assistance, questions or Parts.

"CELTIC" BISTRO WINE RACK

Assembly Instructions

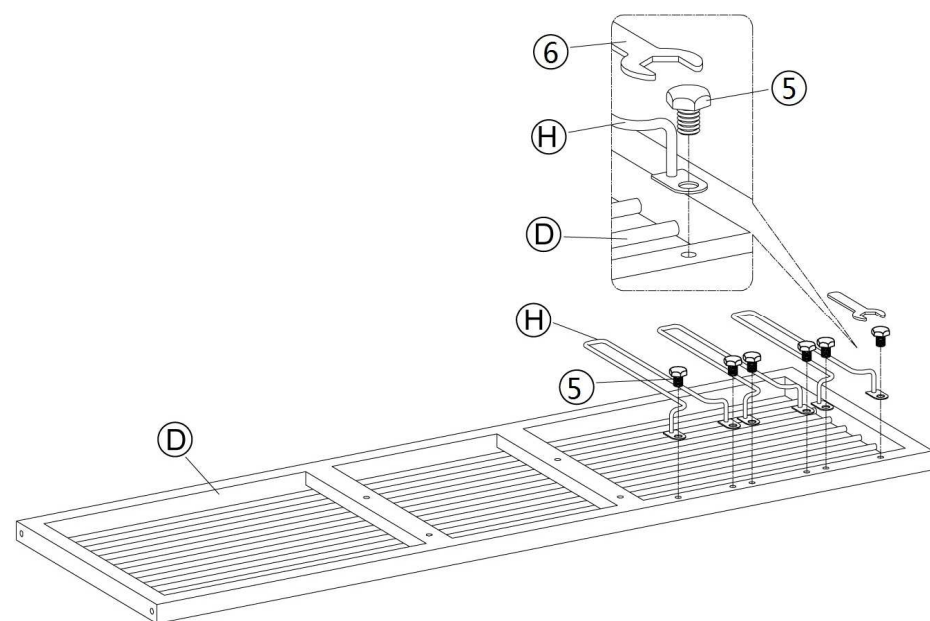

Figure 1

Assembly Instructions:

Unpack and lay parts on clean, padded surface like carpet or blanket. Check that you have all parts indicated on the front page.

Turn over the top shelf frame(D), then Insert 6pcs short bolt (5) through holes on cup holder(H) to attach 3pcs cup holder (H) to top shelf frame(D), by Wrench (6).

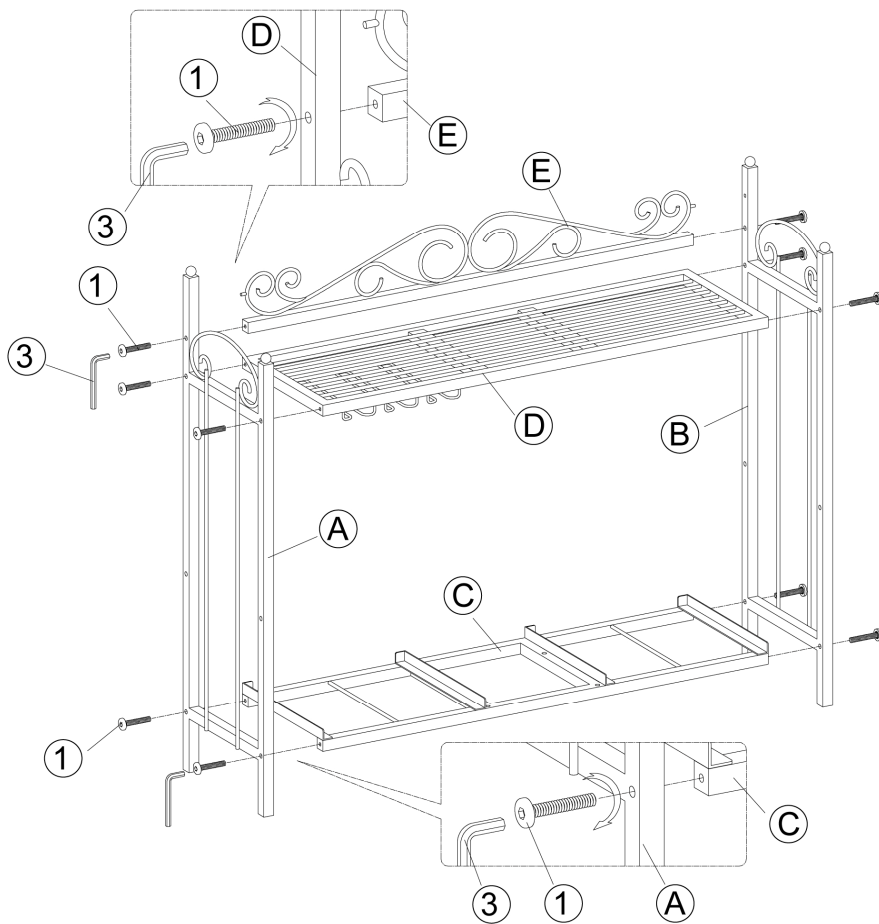

Figure 2

Please insert back decorative panel(E) into the holes on 2pcs side frame(A & B) and then insert 2pcs bolt (1) through holes on side Frame(A & B) to attach back decorative panel (E) to side frame (A & B), by Wrench (3).

Insert 4pcs bolt (1) through holes on side Frame(A & B) to attach 1pc top shelf frame(D) to side frame (A & B) , by Allen Wrench (3).

Insert 4pcs bolt (1) through holes on side Frame(A & B) to attach 1pc Bottom frame(C) to side frame (A & B) , by Allen Wrench (3).

"CELTIC" BISTRO WINE RACK

Assembly Instructions

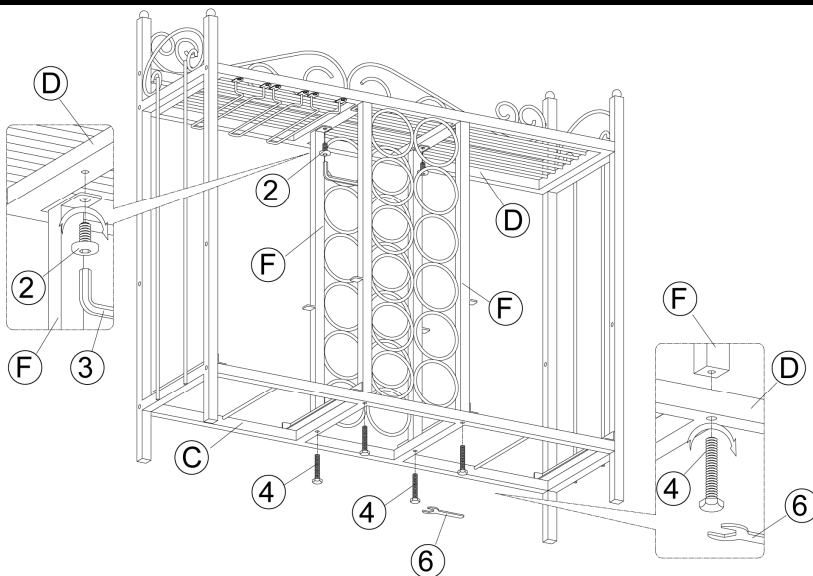

Figure 3

Insert 4pcs short bolt (2) through holes on Wine frame(F) to attach 2pcs Wine frame(F) to top shelf frame (D) , by Allen Wrench (3).

Insert 4pcs Long bolt (4) through holes on bottom Frame(C) to attach 2pcs Wine frame(F) to bottom frame (C) , by Wrench (6).

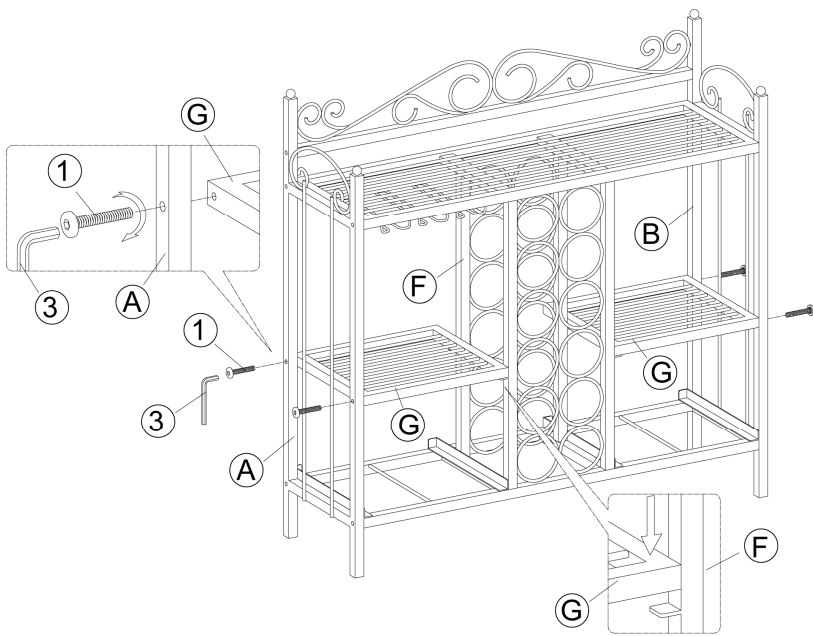

Figure 4

Please put the small shelf frame (G) onto wine frame (F) and Insert 4pcs long bolt (1) through holes on side Frame(A & B) to attach 2pcs small shelf(G) to side frame (A & B) , by Allen Wrench (3).

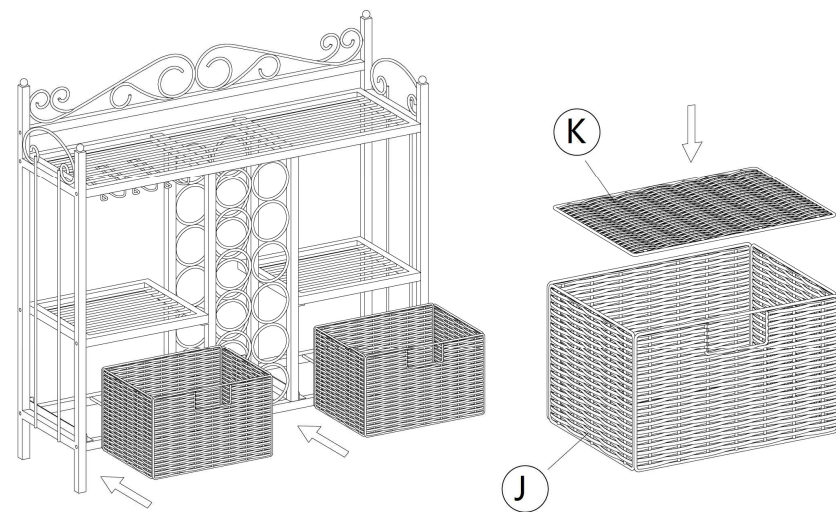

Figure 5

Please put Basket Bottom Panels (K) into Wicker Baskets (J) by hands.

Then put the 2pcs complete baskets onto Bottom frame (C).

Now your drawer wicker storage is ready to use

Parts Replacement Form

Customer Information

Name _____

Address _____

City/State/Zip Code _____

Phone Number _____

Please indicate where you purchased this item: Store/Website/Catalog

Please indicate color/size/style number:

Style No	Parts Letter	Parts Description	Quantity Needed
----------	--------------	-------------------	-----------------

Please immediately examine this product carefully. Any request for missing parts or damage replacement must be received within 90 days of your receipt of the product. Replacement, if available, will be honored within this time frame. Parts will not be available for items arriving fully assembled. We do not recommend modifying product(s) and we are not responsible for any damages due to product modification(s). If damages or missing parts are not reported within 90 days of your receipt, we are under no obligation to provide parts or replacement merchandise.

Please contact Southern Enterprises at 800-633-5096 or in Dallas 972-869-0111/ 9am – 4pm Mon-Fri Central time if you have product issues or email us at service@seidal.com. Please ask for customer service representative for issues involving damages or replacement parts. Please ask for technical assistance representative for any issues with product and assembly/construction.

Please contact the retailer that you purchased from for returns.



Customer Service 1-800-633-5096
service@seidal.com
Southern Enterprises, Inc.
600 Freeport Parkway, Suite 200
Coppell, Texas 75019