

HZ763100TX

Phone Booth Media Cabinet  
Assembly Instructions



Southern  
ENTERPRISES

For assistance with assembly, contact:  
Southern Enterprises Inc.  
Customer Service: 1-800-633-5096  
service@seidal.com  
www.seidal.com

PO#:13639

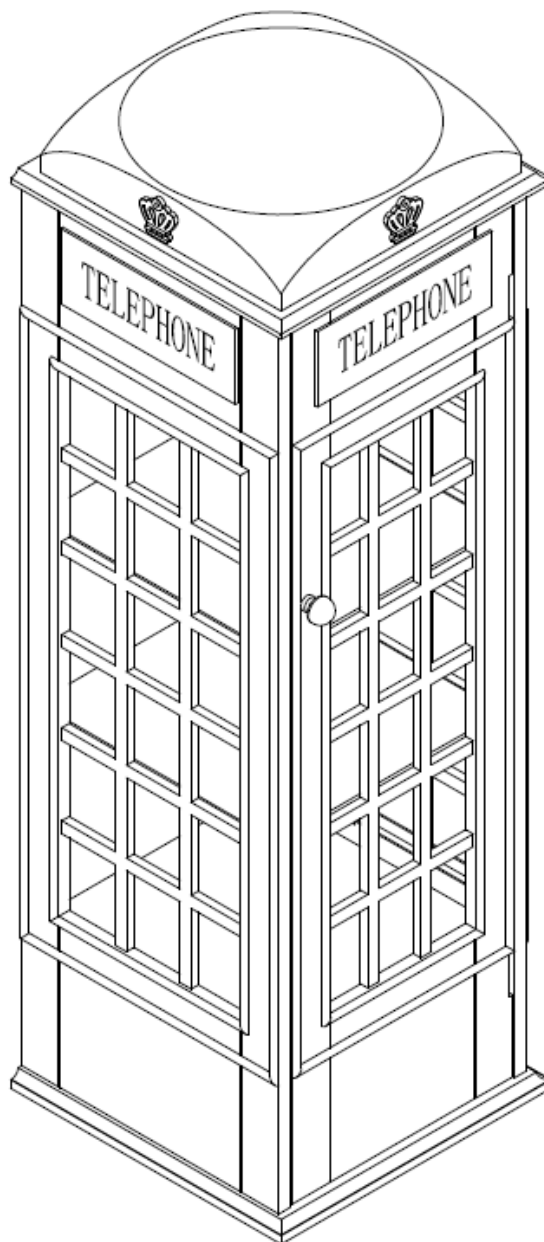

# Phone Booth Media Cabinet

HZ763100TX

## Hardware List

Please check packaging for all parts and hardware before discarding.

Call Customer Service if hardware is missing. Do not return to store/retailer.

Before beginning assembly, carefully study the diagrams below and sort your hardware according to the pictures. Using the incorrect hardware will cause damage.

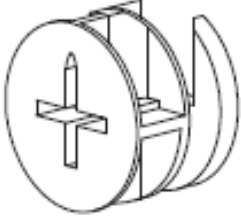
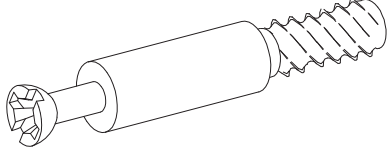
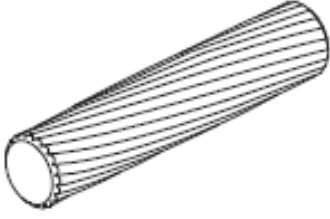
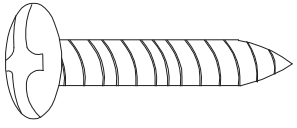
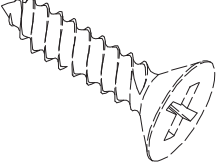
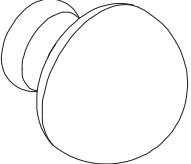
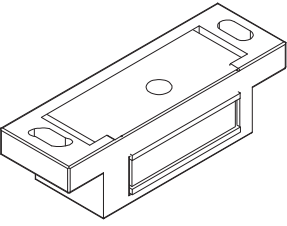
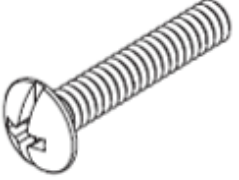

<b>A</b>  Cam Lock Ø 15x10MM	<b>B</b>  Cam Bolt Ø 7x38MM
<b>C</b>  Wood Dowel Ø 8x30MM	<b>D</b>  Round Head Screw Ø 7x14MM
<b>E</b>  Flat Head Screw Ø 6x12MM	<b>F</b>  Wooden Knob Ø 28x38MM
<b>G</b>  Magnet 45x16x12MM	<b>H</b>  Round Head Bolt Ø 8x19MM

# Phone Booth Media Cabinet

HZ763100TX

## Parts List

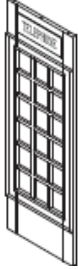
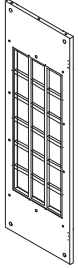
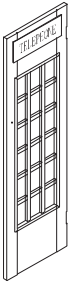
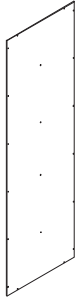
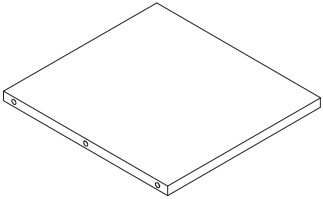
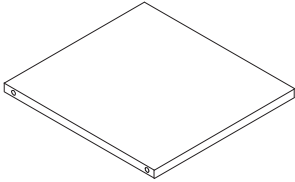
Please check packaging for all parts and hardware before discarding.  
Call Customer Service if hardware is missing. Do not return to store/retailer.  
Before beginning assembly, carefully study the diagrams below and sort your hardware according to the pictures. Using the incorrect hardware will cause damage.

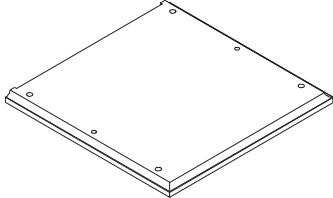
<p>(1)</p>  <p>Quantity of 1</p> <p>Left Side Panel</p>	<p>(2)</p>  <p>Quantity of 1</p> <p>Right Side Panel</p>
<p>(3)</p>  <p>Quantity of 1</p> <p>Door</p>	<p>(4)</p>  <p>Quantity of 1</p> <p>Back Panel</p>
<p>(5)</p>  <p>Quantity of 2</p> <p>Shelf</p>	<p>(6)</p>  <p>Quantity of 2</p> <p>Shelf</p>
<p>(7)</p>  <p>Quantity of 1</p> <p>Top</p>	<p>(8)</p>  <p>Quantity of 1</p> <p>Base</p>

Care and Cleaning Instructions:  
Before using, wipe with a clean, dry cloth.  
Periodically apply furniture wax to renew the finish. Avoid rubbing or scratching the surface with rough or abrasive objects.

For replacement parts or questions, please  
Call Customer Service at 1-800-633-5096.

**Assembly Tool Required**

**No.2 Phillips Screwdriver (Not Included)**

# Phone Booth Media Cabinet

HZ763100TX

## Assembly Instructions

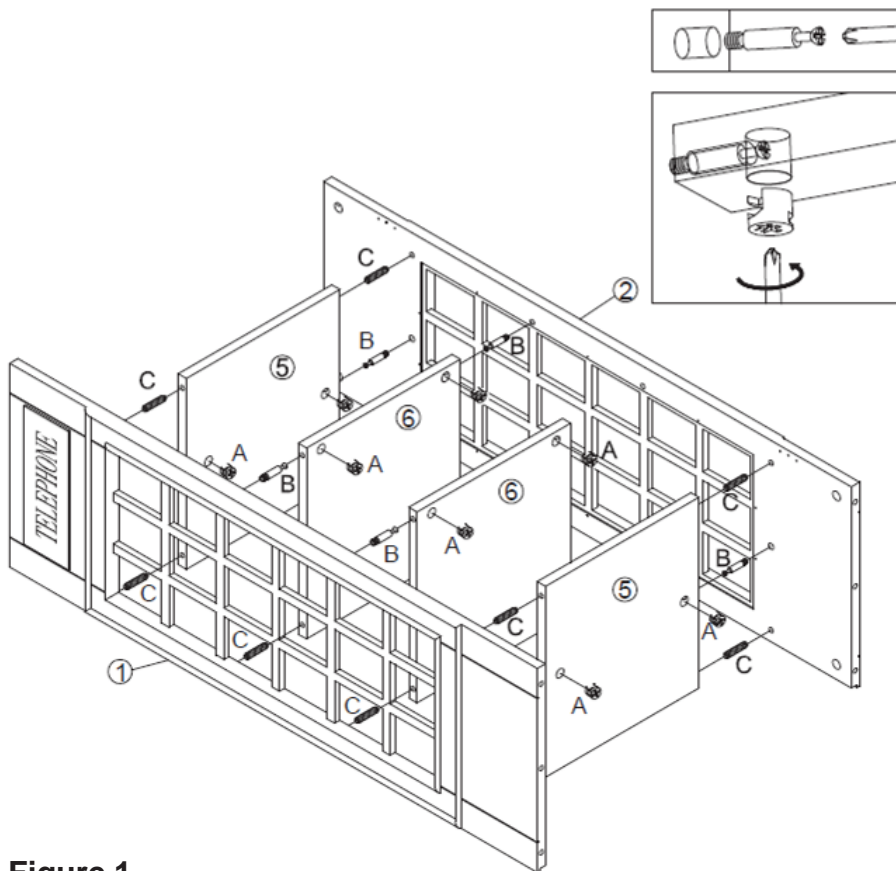

Figure 1

Insert Cam Locks **(A)** into corresponding holes on Shelves **(5/6)**.

Screw Cam Bolts **(B)** into threaded holes on Left Side Panel **(1)** & Right Side Panel **(2)**.

Attach Left Side Panel **(1)** & Right Side Panel **(2)** to Shelves **(5/6)** by inserting Wood Dowels **(C)** & Cam Bolts **(B)** into corresponding holes until all panels meet.

Secure by rotating Cam Locks **(A)** clockwise with Phillips screwdriver.

Note: Panels **(5)** are attached at the very top and very bottom of the unit.

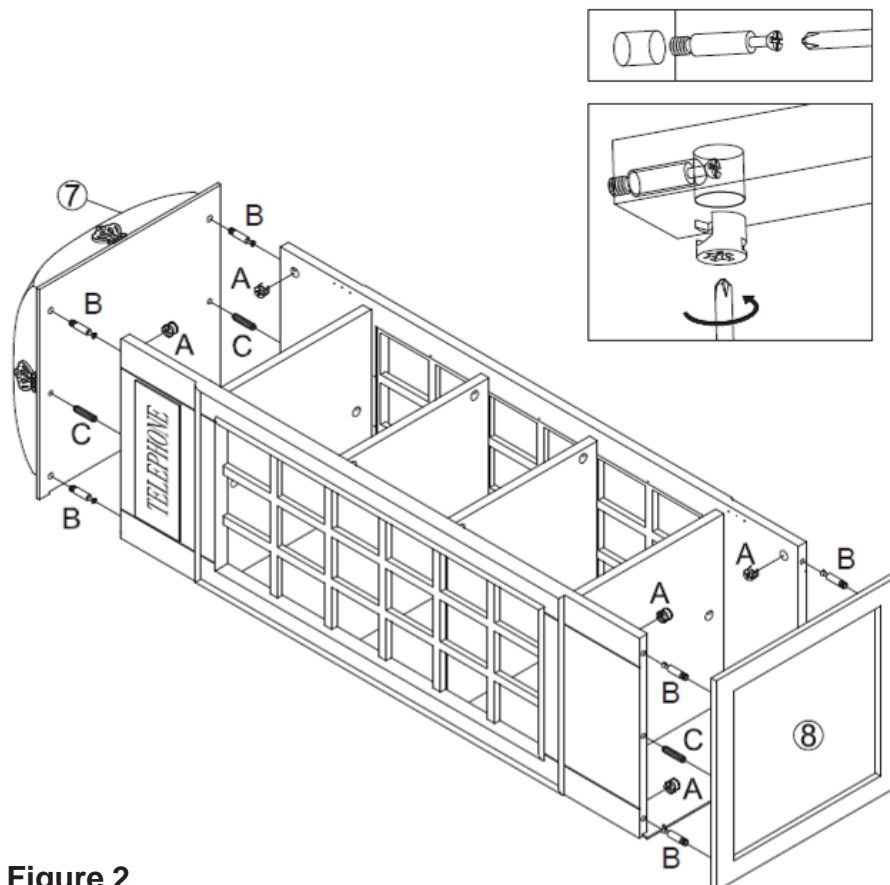

Figure 2

Insert Cam Locks **(A)** into corresponding holes on Left Side Panel **(1)** and Right Side Panel **(2)**.

Screw Cam Bolts **(B)** into threaded holes on Top **(7)** and Base **(8)**.

Attach Top **(7)** to the top of the assembled unit by inserting Cam Bolts **(B)** and Wood Dowels **(C)** into corresponding holes until all panels meet.

Rotate Cam Locks **(A)** clockwise to secure panels.

Repeat steps to attach Base **(8)** to the bottom of the assembled unit.

# Phone Booth Media Cabinet

HZ763100TX

## Assembly Instructions

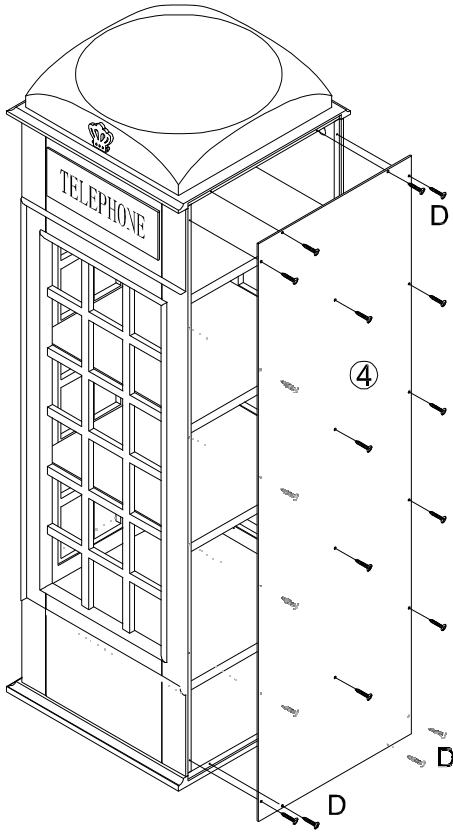

Figure 3

Attach Back Panel (4) by inserting Round Head Screws (D) into corresponding predrilled holes and tightening with Phillips screwdriver.

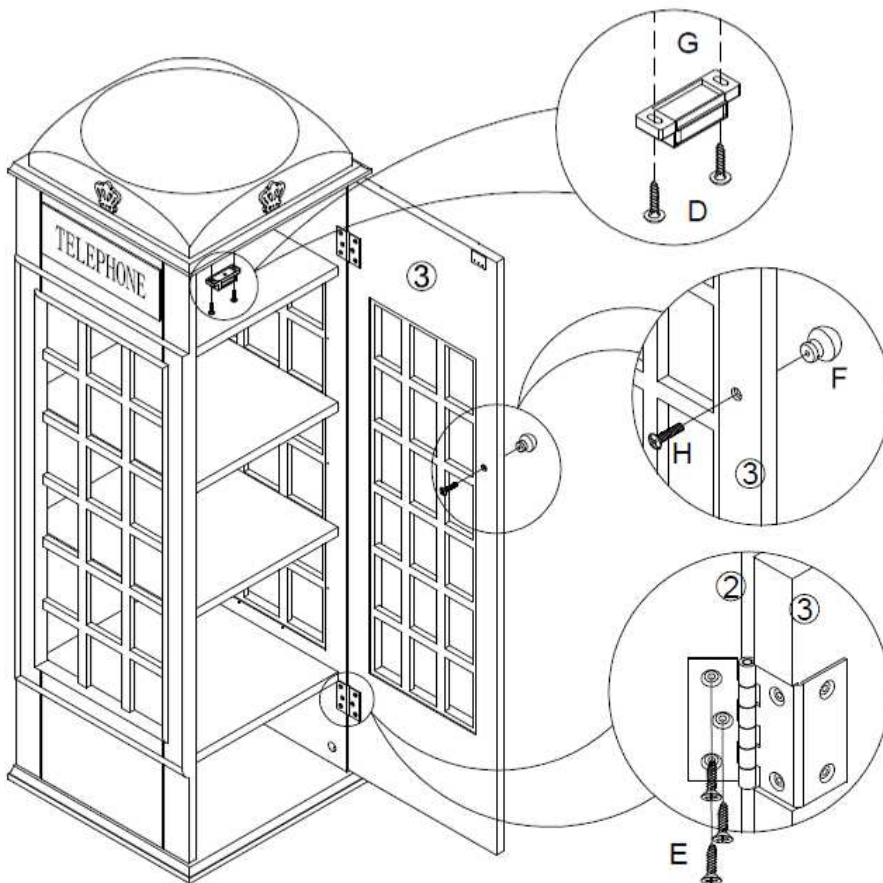

Figure 4

Use Round Head Screws (D) connect Magnet (G) to Top (7).  
Attach Door (3) to assembled unit with Flat Head Screws (E).  
Use Round Head Bolt (H) to attach Wooden Knob (F) to Door (3).

# Phone Booth Media Cabinet

HZ763100TX

## Assembly Instructions

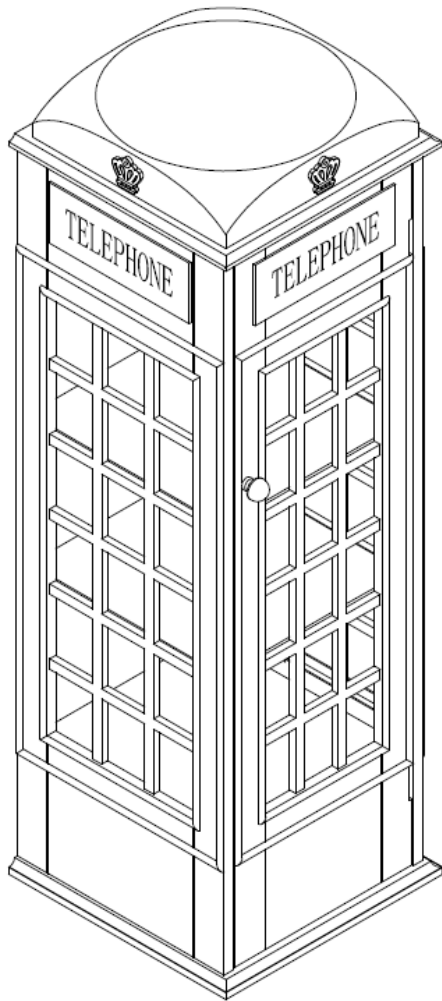

Now your new phone booth is ready to use.

**Figure 5**

# Parts Replacement Form

## Customer Information

Name \_\_\_\_\_

Address \_\_\_\_\_

City/State/Zip Code \_\_\_\_\_

Phone Number \_\_\_\_\_

Please indicate where you purchased this item: Store/Website/Catalog

\_\_\_\_\_

Please indicate color/size/style number

\_\_\_\_\_

Style No	Parts Letter	Parts Description	Quantity Needed
_____	_____	_____	_____
_____	_____	_____	_____
_____	_____	_____	_____

Please immediately examine this product carefully. Any request for missing parts or damage replacement must be received within 90 days of your receipt of the product. Replacement, if available, will be honored within this time frame. Parts will not be available for items arriving fully assembled. We do not recommend modifying product(s) and we are not responsible for any damages due to product modification(s). If damages or missing parts are not reported within 90 days of your receipt, we are under no obligation to provide parts or replacement merchandise. Please contact Southern Enterprises at 800-633-5096 or in Dallas 972-869-0111/ 9am – 4pm Mon-Fri Central time if you have product issues or email us at [service@seidal.com](mailto:service@seidal.com). Please ask for customer service representative for issues involving damages or replacement parts. Please ask for technical assistance representative for any issues with product and assembly/construction.

Please contact the retailer that you purchased from for returns.



**Southern**  
ENTERPRISES

Customer Service 1-800-633-5096  
[service@seidal.com](mailto:service@seidal.com)  
Southern Enterprises, Inc.  
600 Freeport Parkway, Suite 200  
Coppell, Texas 75019