

KA980100TX "CELTIC" BAKERS RACK

Assembly Instructions

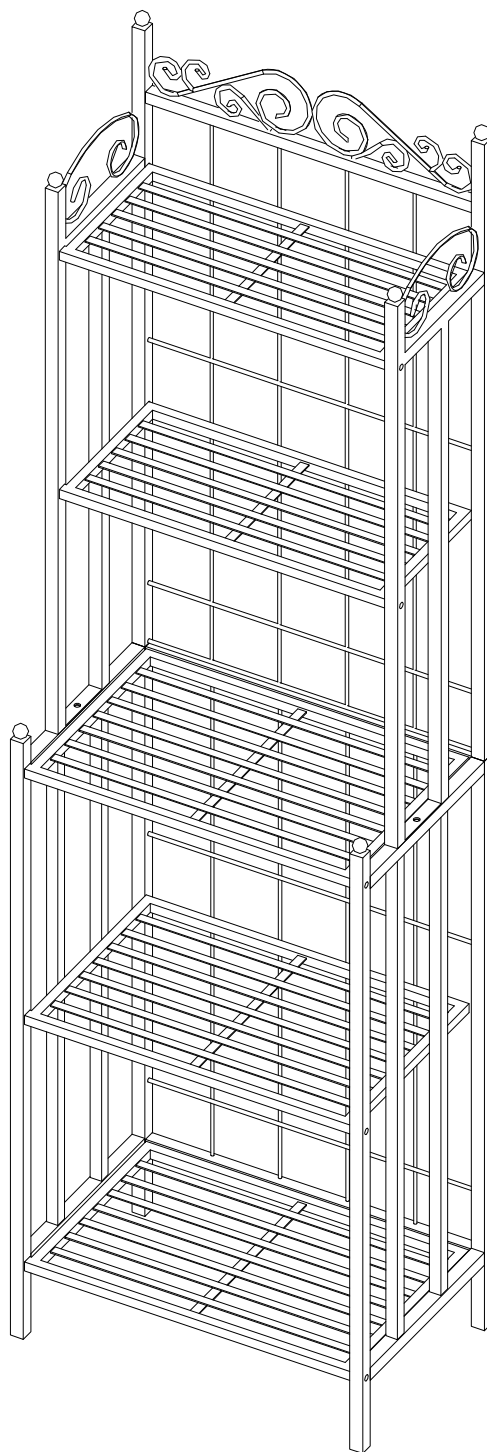

For assistance with assembly contact:
Southern Enterprises Inc.
Customer Service 1-800-633-5096
service@seidal.com
www.seidal.com



"CELTIC" BAKERS RACK

Parts List

Please review all parts and hardware before disposing of any packaging. Call Customer Service if missing hardware. Do not return to store/retailer. crews shown in actual size. Using a screw that is too long will cause damage. Before beginning assembly, separate each type of screw. Carefully study the screw diagrams below (SHOWN ACTUAL SIZE). You may receive extra hardware with your unit.

A Upper Back Frame

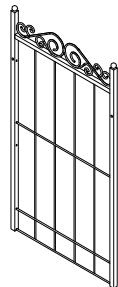

Quantity
of 1

B Lower back Frame

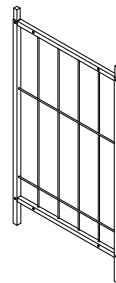

Quantity
of 1

C Lower side panel

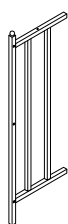

Quantity
of 2

D Upper side panel

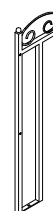

Quantity
of 2

E Lower shelf frame

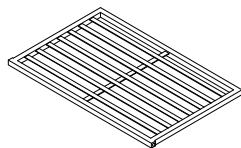

Quantity
of 2

F Lower middle shelf frame

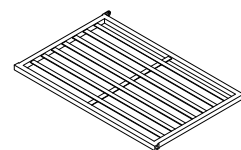

Quantity
of 1

G Upper shelf frame

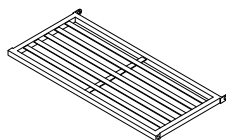

Quantity
of 2

1 . Long Bolt

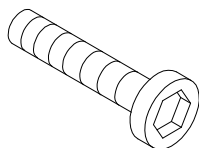

Quantity
of 16

1/4"*1-1/4"

2 . Middle Bolt

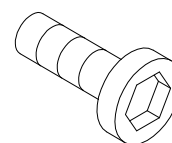

Quantity
of 4

1/4"*3/4"

3 . Short Bolt

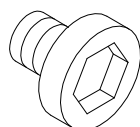

Quantity
of 10

1/4"*1/2"

4 . Allen Wrench



Quantity
of 1

Care and Cleaning Instructions:

Before using, wipe with a clean, dry cloth. Periodically apply furniture wax to renew the finish . Avoid rubbing or scratching the

For replacement parts or questions, please Call Customer Service at 1-800-633-5096 Do not return product to store, please call Manufacturer for assistance, questions or Parts.

Assembly Tool Required
No.2 Phillips Screwdriver (Not Included)

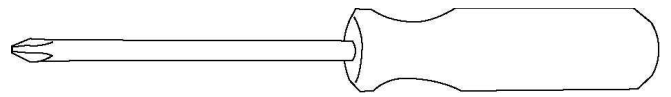

"CELTIC" BAKERS RACK

Assembly Instructions

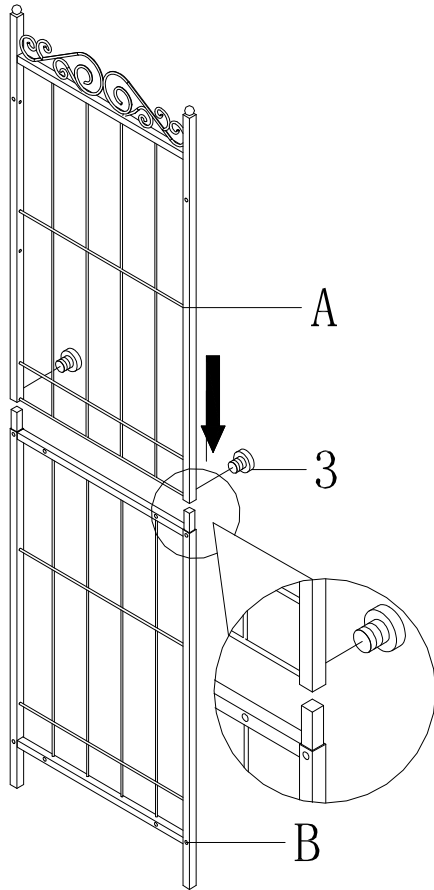
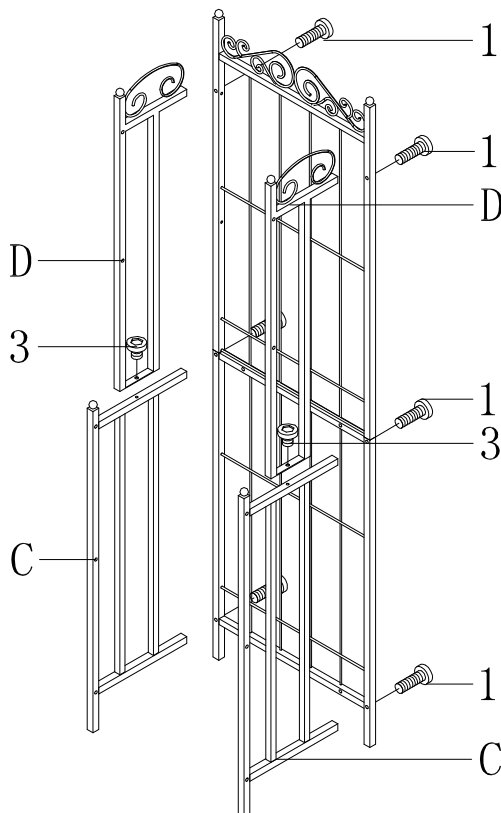

Figure 1

Assembly Instructions:

Unpack and lay parts on clean, padded surface like carpet or blanket. Check that you have all parts indicated on the front page.

Please insert Upper back panel(A) into lower back panel(B) and then Insert 2pcs Short bolt (3) through holes on back Frame(A) to attach bottom back Frame(B)



Insert 4pcs long bolt (1) through holes on lower back frame (B) to attach 2pcs lower side panel(C)

Insert 2pcs long bolt (1) through holes on Upper back frame (A) to attach 2pcs Upper side panel(D), then inser 2pcs short bolt(3) through holes on Upper side panel(D) to attach 2pcs Bottom side panel(C)

Figure 2

"CELTIC" BAKERS RACK

Assembly Instructions

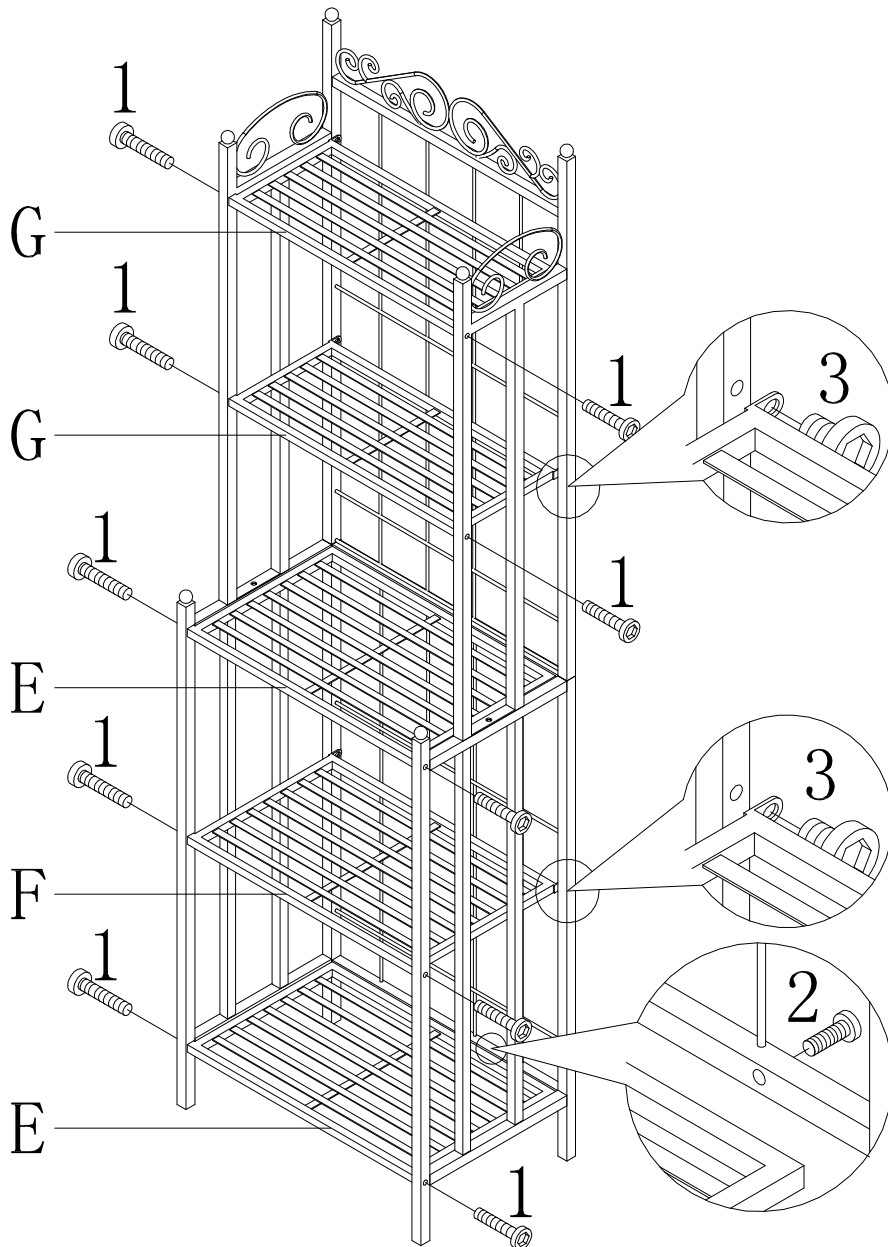

Insert 4pcs long bolt (1) through holes on lower side panel (C) to attach the 2pcs lower shelf (E), and insert 4pcs Middle bolt (2) through holes on lower back Frame (B) to attach the 2pcs lower shelf (E)

Insert 2pcs long bolt (1) through holes on lower side panel (C) to attach the lower middle shelf(F) and Insert 2pcs short bolt (3) through holes on middle shelf (F) to attach the lower back Frame(B)

Insert 4pcs long bolt (1) through holes on upper side panel (D) to attach the 2pcs upper shelf (G) and Insert 4pcs short bolt (3) through holes on small wire shelf (G) to attach the Upper back Frame(A)

Figure 3



Customer Service 1-800-633-5096

service@seidal.com

Southern Enterprises Inc.

2915 Merrell Road

Dallas, Texas 75229

KA980100TX - Parts Replacement Form

Customer Information

Name

Address

City/State/Zip Code

Phone Number

Please indicate where you purchased this item: Store/Website/Catalog

Please indicate color/size/style number:

Style No

Parts Letter

Parts Description

Quantity Needed

Missing or damaged hardware and/or parts will be replaced free of charge. We do not sell parts. Southern Enterprises Inc. will provide replacement parts for only those items purchased within the last 9 months. If this product has not been purchased from our retail affiliates (within 9 months), we are under no obligation to provide parts or replacement merchandise. Parts will not be available for items arriving fully assembled. Parts will be sent if available from SEI