

CK927000TX

MIRRORED COCKTAIL TABLE

Assembly Instructions



Southern
ENTERPRISES

For assistance with assembly contact:
Southern Enterprises Inc.
Customer Service 1-800-633-5096
service@seidal.com
www.seidal.com

PO:12813

Top supports up to 50 lb.







CK927000TX

MIRRORED COCKTAIL TABLE

Parts List

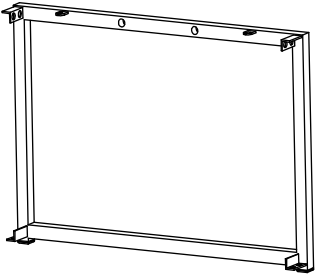
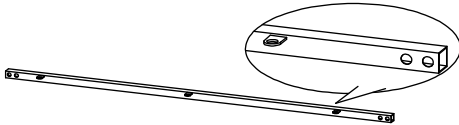
Please review all parts and hardware before disposing of any packaging.
Call Customer Service if missing hardware.

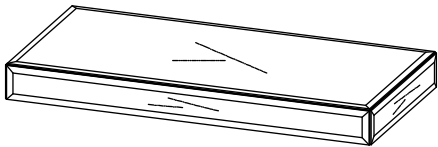
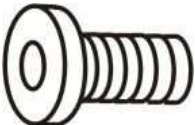
Using a screw that is too long will cause damage. Before beginning assembly, separate each type of screw. Carefully study the screw diagrams below.

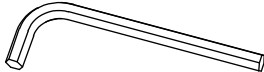
<p>1 2PCS</p>  <p style="text-align: center;">SIDE PANEL</p>	<p>2 2PCS</p>  <p style="text-align: center;">TOP STRETHCER</p>	<p>3 2PCS</p>  <p style="text-align: center;">BOTTOM STRETCHER</p>
<p>4 1PC</p>  <p style="text-align: center;">CENTER PANEL</p>	<p>5 1PC</p>  <p style="text-align: center;">MIRRORED TOP</p>	
<p>A 26PCS</p>  <p style="text-align: center;">SCREW 1/4"x 5/8"</p>	<p>B 4PCS</p>  <p style="text-align: center;">SCREW 1/4"x 1-1/4"</p>	<p>C 1PC</p>  <p style="text-align: center;">WRENCH</p>

Care and Cleaning Instructions:
Before using, wipe with a clean, dry cloth.

Avoid rubbing or scratching the surface with rough or abrasive objects.

For replacement parts or questions, please
Call Customer Service at 1-800-633-5096

Do not return product to store, please call manufacturer for assistance, questions or parts.

Assembly Tool Required
No.2 Phillips Screwdriver

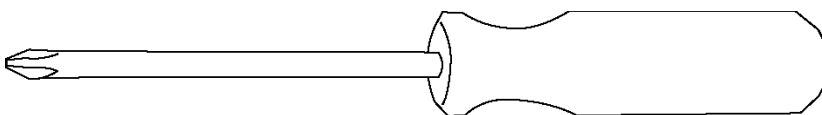

CK927000TX

MIRRORED COCKTAIL TABLE

Assembly Instructions

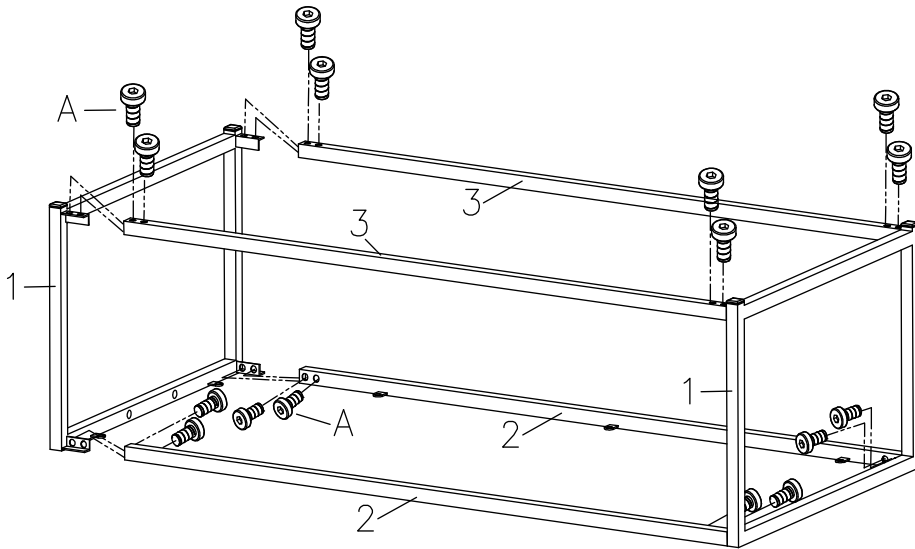

Figure 1

Step 1:

Notice: Please do not tighten screws completely until all the screws are in place.

Unit assembly should begin with parts turned upside down for Step 1.

Attach top stretcher (2) and bottom stretcher (3) to side panels (1) using screws (A) as shown

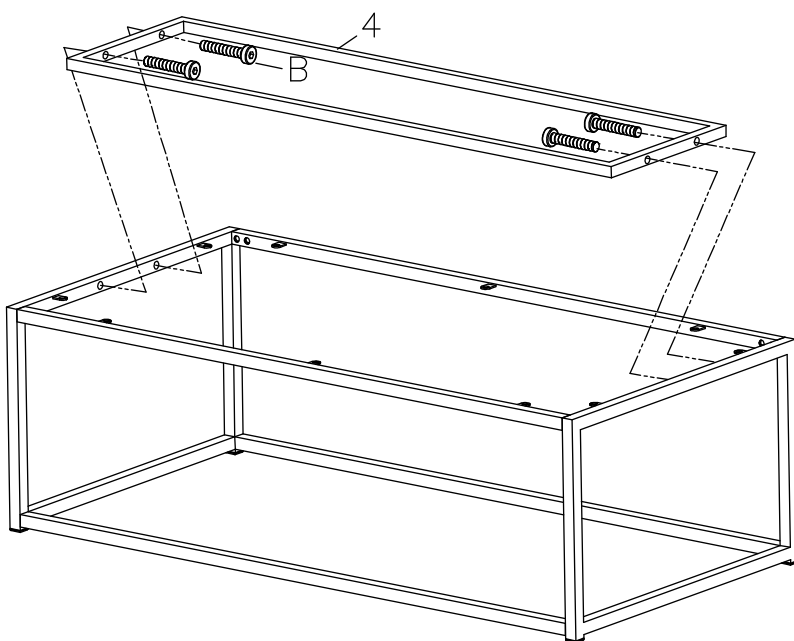

Figure 2

Step 2:

Turn the assembled metal base upright and attach center panel (4) using screws (B), then fully tighten all screws.

Step 3:

Carefully attach mirrored top (5) to the metal base using screws (A) as shown.

Your mirrored cocktail table assembly is now complete.

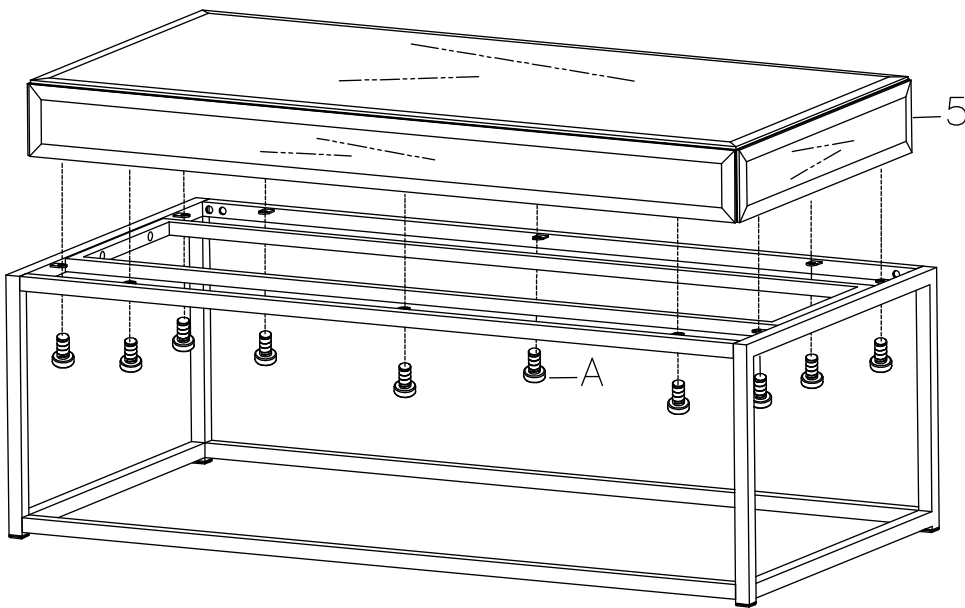

Figure 3



Southern
ENTERPRISES

Customer Service 1-800-633-5096
service@seidal.com
Southern Enterprises, Inc.
600 Freeport Parkway, Suite 200
Coppell, Texas 75019

Parts Replacement Form

Customer Information

Name

Address

City/State/Zip Code

Phone Number

Please indicate where you purchased this item: Store/Website/Catalog

Please indicate color/size/style number:

Please immediately examine this product carefully. Any request for missing parts or damage replacement must be received within 90 days of your receipt of the product. Replacement, if available, will be honored within this time frame. Parts will not be available for items arriving fully assembled. We do not recommend modifying product(s) and we are not responsible for any damages due to product modification(s). If damages or missing parts are not reported within 90 days of your receipt, we are under no obligation to provide parts or replacement merchandise.

Please contact Southern Enterprises at 800-633-5096 or in Dallas 972-869-0111/ 9am – 4pm Mon-Fri Central time if you have product issues or email us at service@seidal.com. Please ask for customer service representative for issues involving damages or replacement parts. Please ask for technical assistance representative for any issues with product and assembly/construction.

Please contact the retailer that you purchased from for returns.



Southern
ENTERPRISES

Customer Service 1-800-633-5096
service@seidal.com
Southern Enterprises, Inc.
600 Freeport Parkway, Suite 200
Coppell, Texas 75019