

BC117000TX / BC117500TX
SWIVEL BARSTOOL /
COUNTERSTOOL - HANOVER
Assembly Instructions

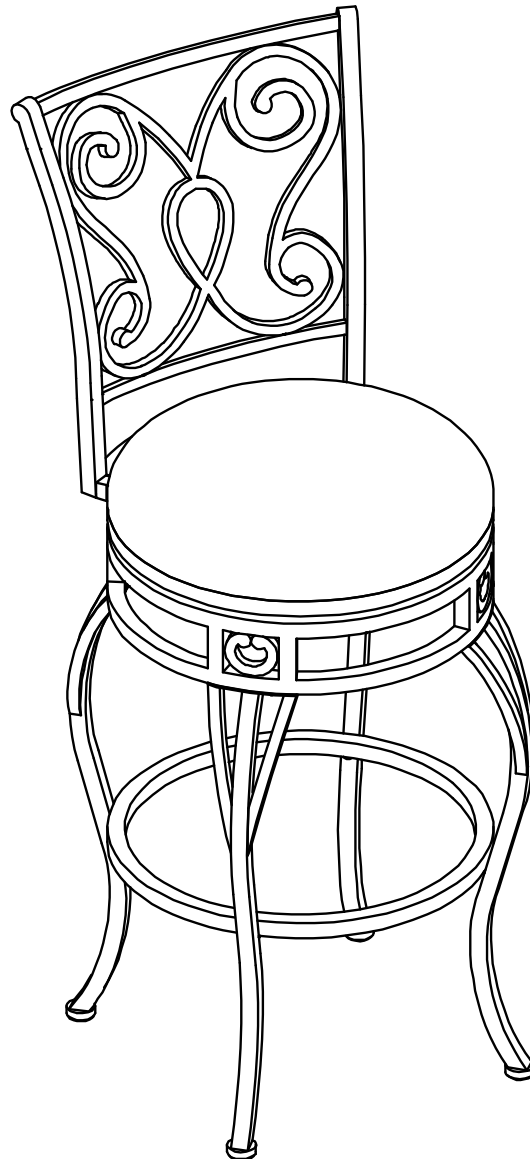







For assistance with assembly contact:
Southern Enterprises, Inc.
Customer Service 1-800-633-5096
service@seidal.com
www.seidal.com

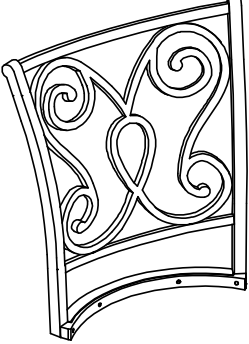
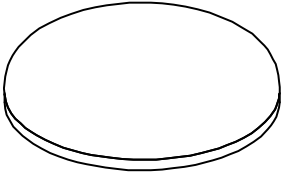

SWIVEL BARSTOOL / COUNTERSTOOL - HANOVER

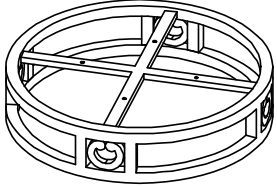
Parts List

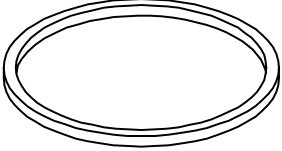
Please review all parts and hardware before disposing of any packaging. Call Customer Service if missing hardware. Do not return to store/retailer. Using a screw that is too long will cause damage. Before beginning assembly, separate each type of screw. Carefully study the screw diagrams below. You may receive extra hardware with your unit.

<p>A</p>  <p>Backrest</p>	<p>B</p>  <p>Seat Cushion With Frame</p>
<p>C</p>  <p>Swivel</p>	<p>D</p>  <p>Seat Frame</p>
<p>E</p>  <p>Legs</p>	<p>F</p>  <p>Foot-Ring</p>
<p>G</p>  <p>Φ1/4"X 1/2"L Bolts</p>	<p>H</p>  <p>Φ1/4"X 5/8"L Bolts</p>

I

4pcs



Φ1/4"X 1-3/8"L Bolts

J

24pcs



Lock Washers

K

24pcs



Washers

L

1pc



Allen Wrench

Care and Cleaning Instructions:

Before using, wipe with a clean, dry cloth.
Avoid rubbing or scratching the
surface with rough or abrasive objects.

For replacement parts or questions, please
Call Customer Service at 1-800-633-5096
Do not return product to store, please call
Manufacturer for assistance, questions or
Parts.

SWIVEL BARSTOOL / COUNTERSTOOL - HANOVER

Assembly Instructions

Figure 1

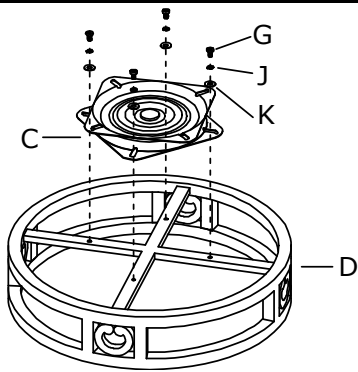

1. Place seat frame (D) upright with crossbar for swivel unit (C) on top as shown.
2. Turn swivel unit (C) so that the two swivel plates are now off-set and are in a star pattern, as shown.
3. Place swivel unit (C) on the crossbar of seat frame (D). Fasten using four bolts (G), four lock washers (J) and four washers (K) as shown. Tighten securely.

Figure 2

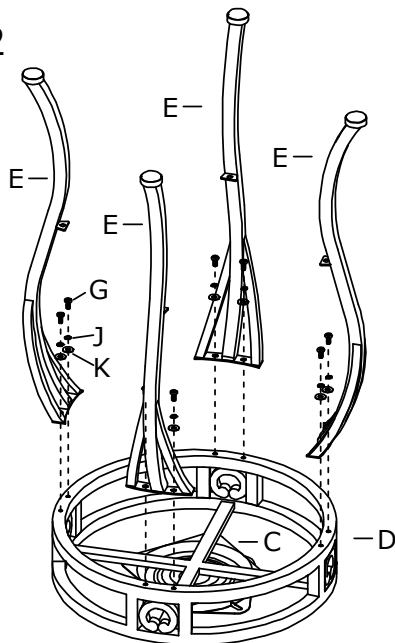

1. Reverse seat frame (D) so that swivel unit (C) is facing down, as shown.
2. Attach four legs (E) to seat frame (D) using eight bolts (G), eight lock washers (J) and eight washers (K). Make sure that each leg (E) is positioned exactly as shown, and that you only tighten the bolts halfway, using the Allen wrench (L).

Figure 3

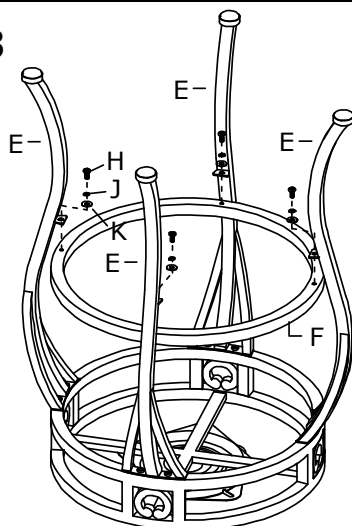

1. Position the foot-ring (F) as shown. Fasten it to the four legs (E) using four bolts (H), four lock washers (J), four washers (K) and Allen wrench (L) exactly as shown.
2. Tighten all bolts from steps 2 & 3 securely.

Figure 4

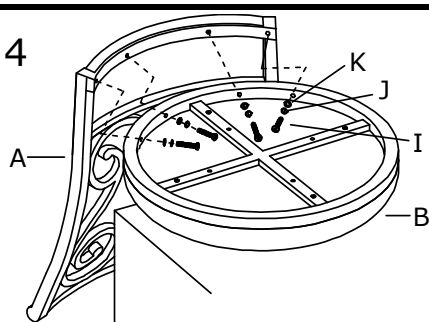

1. Place seat cushion (B) upside down on protected work surface.
2. Place backrest (A) upside down and fasten the backrest (A) to frame of seat cushion (B) securely using a bolt (I), a lock washer (J) and a washer (K) for each hole with the Allen wrench (L), as shown.

Figure 5

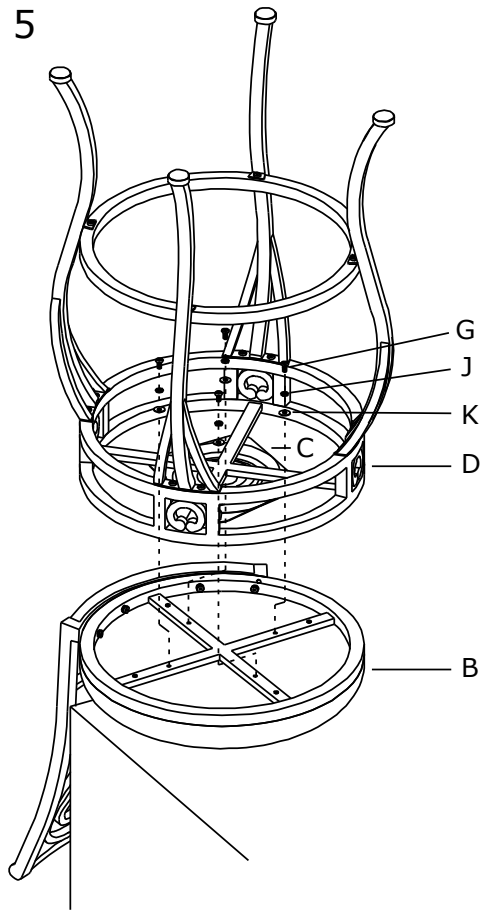

1. Please note that barstool base is still upside-down.
2. Secure seat frame (D) to seat cushion (B) by fastening swivel unit (C) to seat cushion (B) using four bolts (G), four lock washers (J) and four washers (K), using Allen wrench (L).

Figure 6

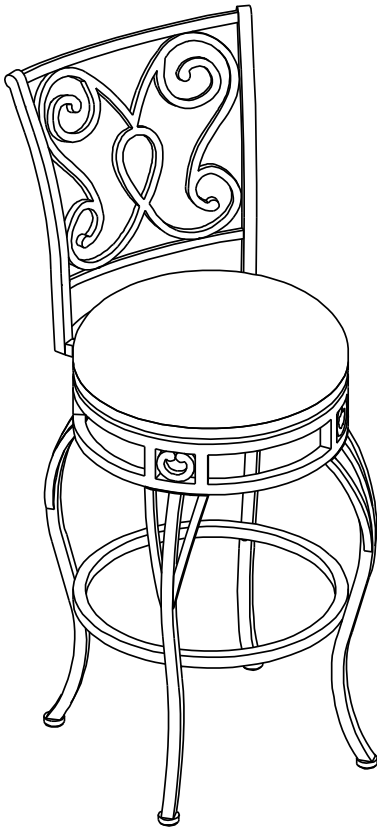

Place barstool upright on the floor.

** We recommend that you save the Allen wrench (L) and periodically tighten all bolts. Please make sure all bolts are placed in their proper positions and then are tightened securely to ensure your safety.

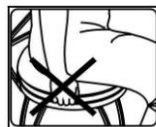

** Warning: to prevent injury, do not insert fingers between the seat and the frame.

** Weight restriction: 250 lbs.

** Intended for indoor use only.

Parts Replacement Form

Customer Information

Name _____

Address _____

City/State/Zip Code _____

Phone Number _____

Please indicate where you purchased this item: Store/Website/Catalog

Please indicate color/size/style number:

Style No	Parts Letter	Parts Description	Quantity Needed
_____	_____	_____	_____
_____	_____	_____	_____
_____	_____	_____	_____

Please immediately examine this product carefully. Any request for missing parts or damage replacement must be received within 90 days of your receipt of the product. Replacement, if available, will be honored within this time frame. Parts will not be available for items arriving fully assembled. We do not recommend modifying product(s) and we are not responsible for any damages due to product modification(s). If damages or missing parts are not reported within 90 days of your receipt, we are under no obligation to provide parts or replacement merchandise. Please contact Southern Enterprises at 800-633-5096 or in Dallas 972-869-0111/ 9am – 4pm Mon-Fri Central time if you have product issues or email us at service@seidal.com. Please ask for customer service representative for issues involving damages or replacement parts. Please ask for technical assistance representative for any issues with product and assembly/construction.

Please contact the retailer that you purchased from for returns.



Customer Service 1-800-633-5096

service@seidal.com

Southern Enterprises, Inc.

600 Freeport Parkway, Suite 200

Coppell, Texas 75019