

CK502000TX

BARROW COCKTAIL

Assembly Instructions



Southern
ENTERPRISES

For assistance with assembly, contact.
Southern Enterprises Inc.
Customer Service 1-800-633-5096
service@seidal.com
www.seidal.com

PO:13876

Top supports up to lb.

Shelf supports up to lb.

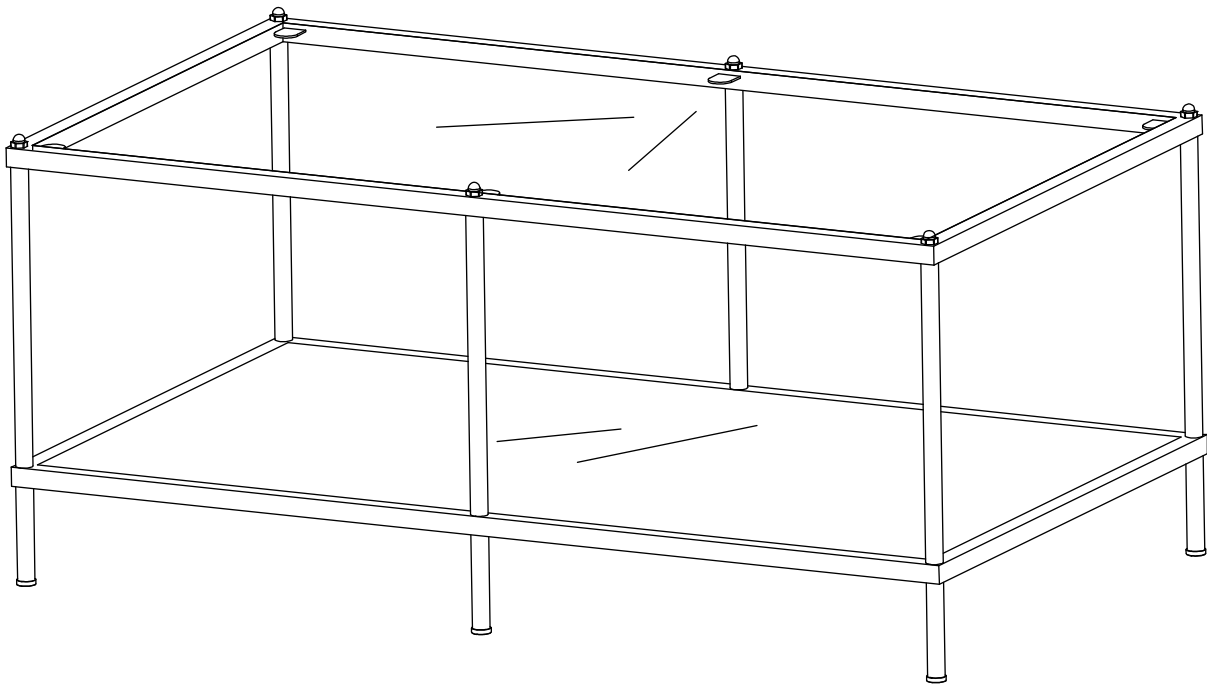

CK502000TX

BARROW COCKTAIL

Parts List

Please review all parts and hardware before disposing of any packaging.

Call Customer Service if missing hardware.

Carefully study the diagrams below.

You may receive extra hardware with your unit.

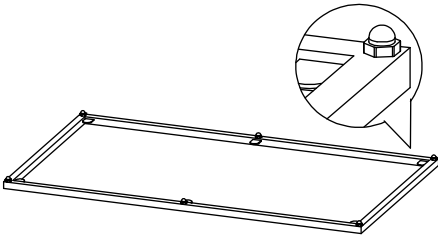
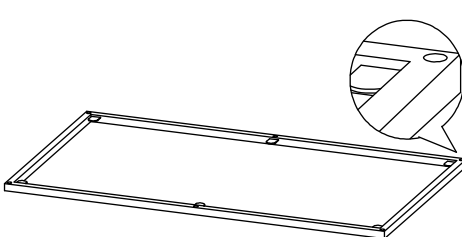
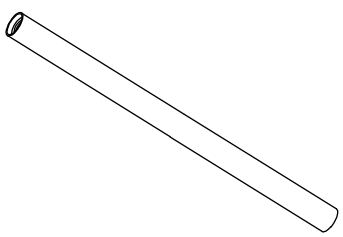
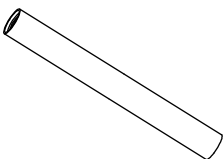
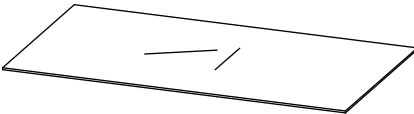
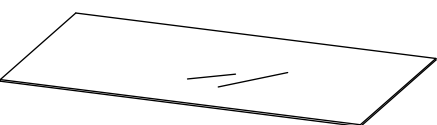
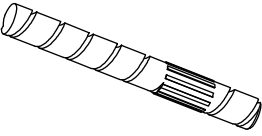
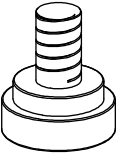
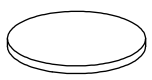
1 1PC  Top Frame	2 1PC  Shelf Frame	3 6PCS  Supports
4 6PCS  Legs	5 1PC  Glass Top	6 1PC  Mirror Shelf
A 12PCS  Screws 1/4"x1-1/2"	B 6PCS  Levelers	C 12PCS  Glass Pads

Care and Cleaning Instructions:

Before using, wipe with a clean, dry cloth.
Avoid rubbing or scratching the surface with rough or abrasive objects.

For replacement parts or questions, please call customer service at 1-800-633-5096.

Assembly Tool Required
No.2 Phillips Screwdriver

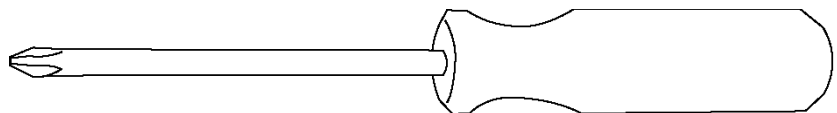

CK502000TX

BARROW COCKTAIL

Assembly Instructions

Step 1:

Unit assembly should begin with parts turned upside down for Step 1.

Attach Screws **(A)** to Top Frame **(1)** and twist Screws **(A)** clockwise to tighten them as shown.

Note: Make sure you're inserting the Screws as they are shown on Figure 1.

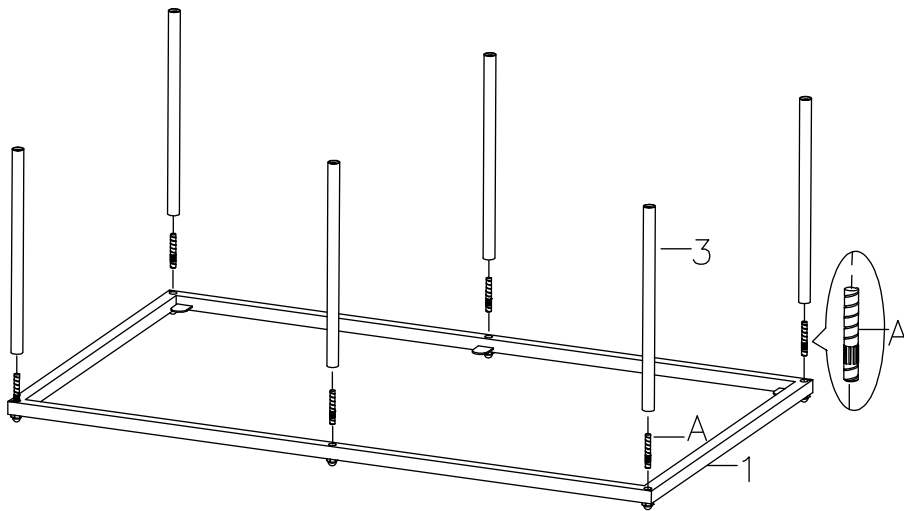

Figure 1

Step 2:

Screw Supports **(3)** onto Screws **(A)** already attached to Top Frame **(1)** from Figure, then, insert Screws **(A)** into Supports **(3)** and tighten by hand.

Attach Shelf Frame **(2)** connecting with Screws **(A)** as shown.

Please make sure the labels reading **BOTTOM** under Shelf Frame **(2)** is facing upwards.

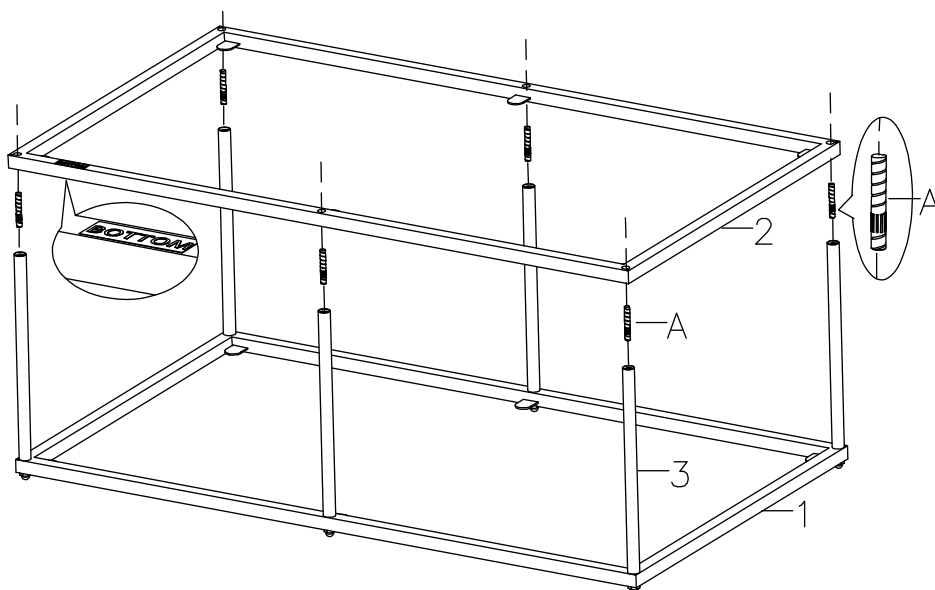

Figure 2

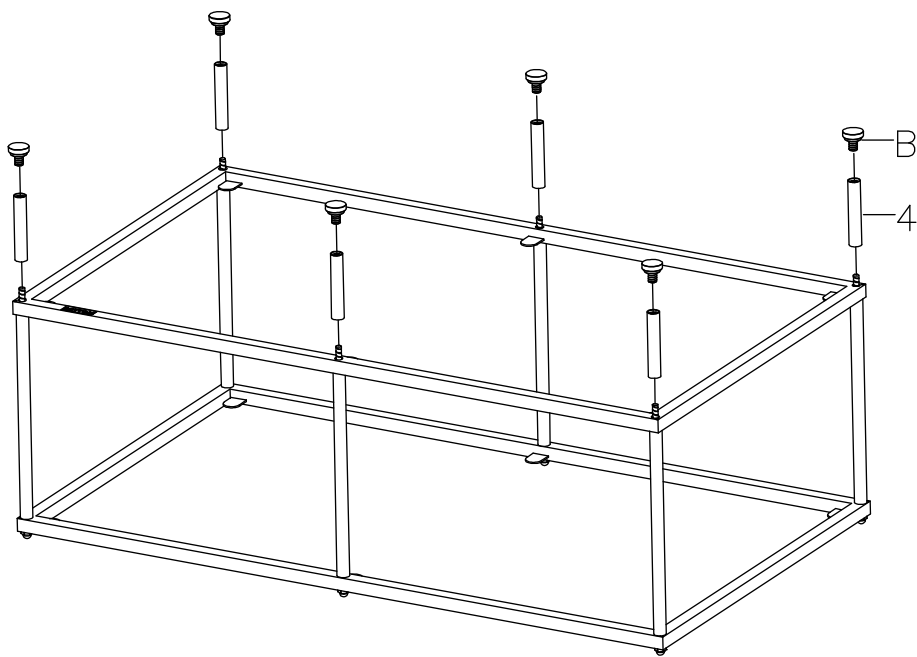

Figure 3

Step 3:

Attach Legs (4) to Screw (A) and attach Levelers (B) to Legs (4) as shown.

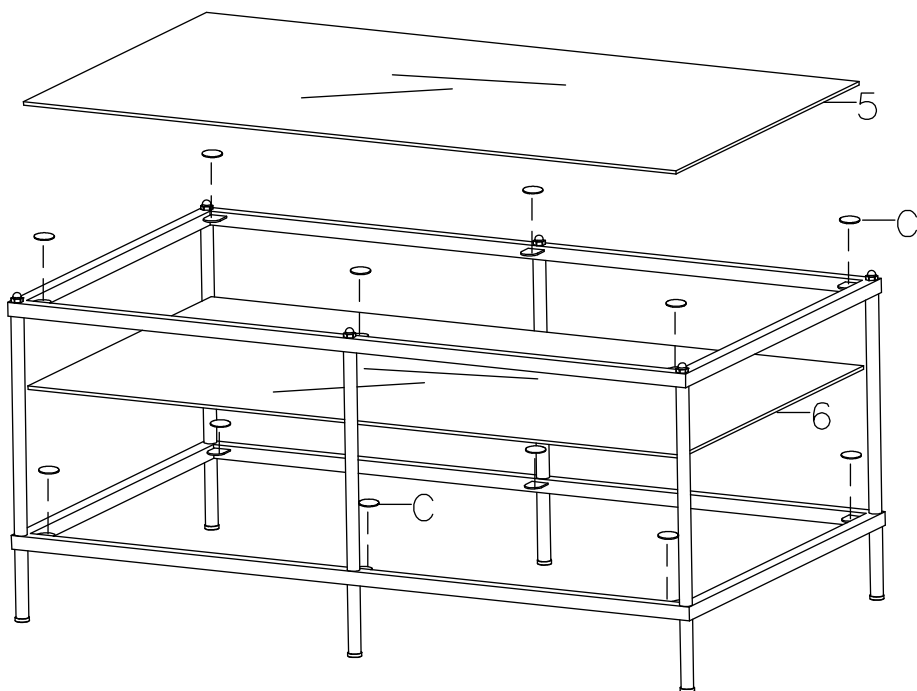

Figure 4

Step 4:

Turn the assembled parts upright.

Attach Glass Pads (C) onto brackets of Top Frame (1) and Shelf Frame (2).

Place Glass Top (5) onto Top Frame (1).

Insert Mirror Shelf (6) onto Shelf Frame (2) as shown.

Now, your Barrow Cocktail is ready to use.

Parts Replacement Form

Customer Information

Name _____

Address _____

City/State/Zip Code _____

Phone Number _____

Please indicate where you purchased this item: Store/Website/Catalog

Please indicate color/size/style number:

Style No	Parts Letter	Parts Description	Quantity Needed
_____	_____	_____	_____
_____	_____	_____	_____
_____	_____	_____	_____

Please immediately examine this product carefully. Any request for missing parts or damage replacement must be received within 90 days of your receipt of the product. Replacement, if available, will be honored within this time frame. Parts will not be available for items arriving fully assembled. We do not recommend modifying product(s) and we are not responsible for any damages due to product modification(s). If damages or missing parts are not reported within 90 days of your receipt, we are under no obligation to provide parts or replacement merchandise.

Please contact Southern Enterprises at 800-633-5096 or in Dallas 972-869-0111/ 9am – 4pm Mon-Fri Central time if you have product issues or email us at service@seidal.com. Please ask for customer service representative for issues involving damages or replacement parts. Please ask for technical assistance representative for any issues with product and assembly/construction.

Please contact the retailer that you purchased from for returns.



Southern
ENTERPRISES

Customer Service 1-800-633-5096

service@seidal.com

Southern Enterprises, Inc.

600 Freeport Parkway, Suite 200

Coppell, Texas 75019