

O2+
Air Purifiers

REVIVE

OWNER'S MANUAL

Revive PR50-W, PR50-B
True HEPA Air Purifier & Humidifier

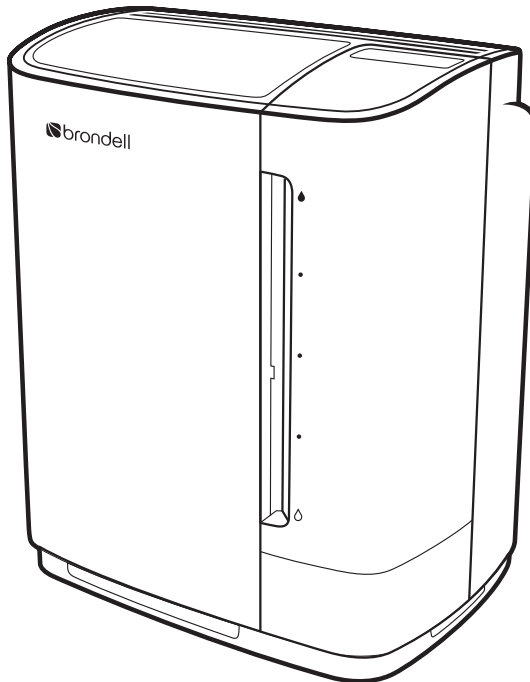

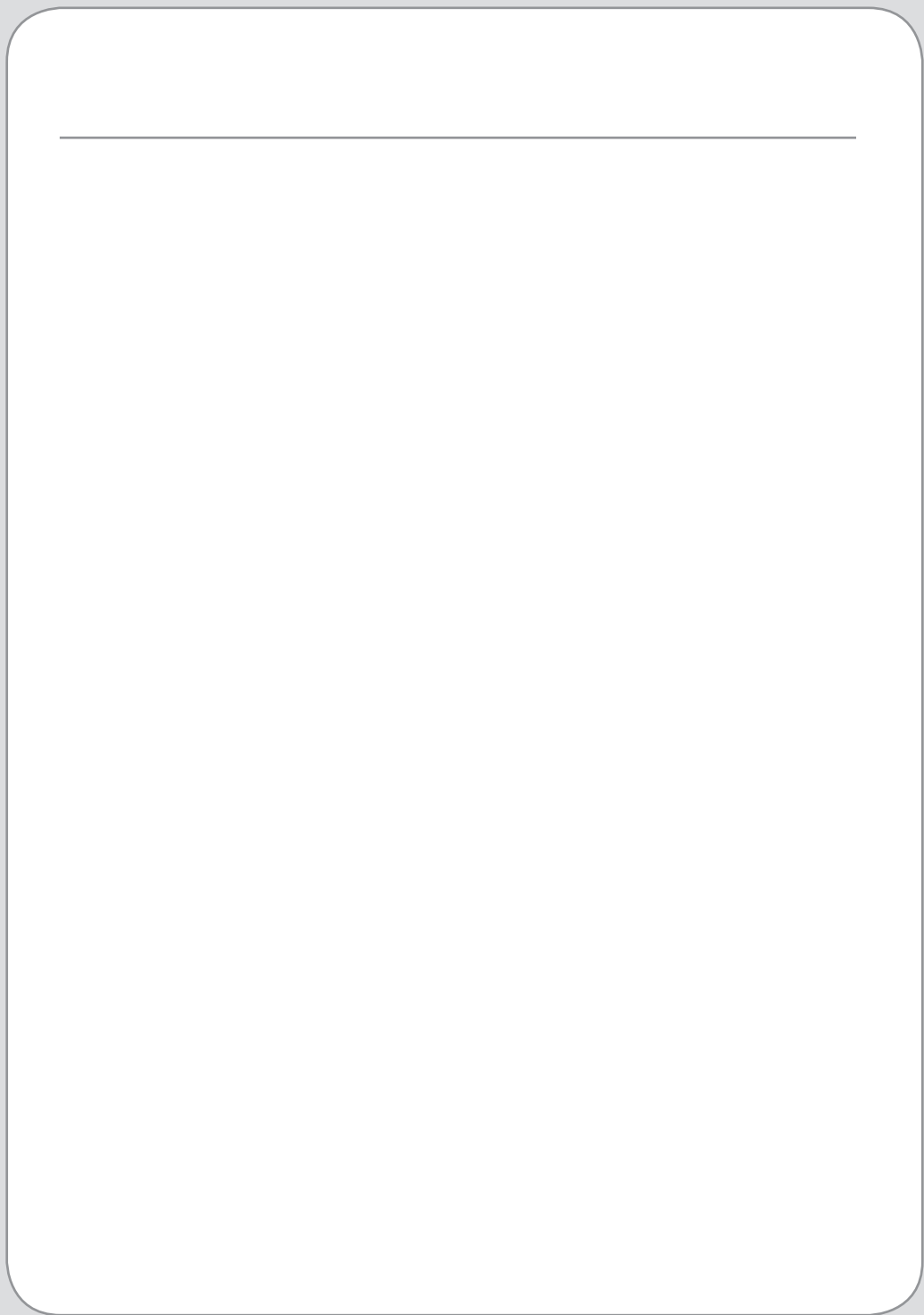

CONTENTS

Read this Owner's Manual for correct installation, use, and maintenance of this product. After reading and completing installation, keep this manual in a place that is easily accessible.

GENERAL INFORMATION

- 2 SAFETY INFORMATION**
- 6 PRODUCT FEATURES**
 - Main Features
 - Evaporative Humidification
- 8 PRODUCT COMPONENTS**
 - Front View
 - Top View
 - Rear View
 - Air Filters
 - Humidifier Components

OPERATION

- 12 CONTROL PANEL**
 - Buttons
 - Indicators
- 14 PREPARING FOR FIRST USE**
 - Installing the Filters
 - Preparing the Humidifier
- 16 PRODUCT OPERATION**
 - Powering the Revive On
 - Operating Modes
 - Automatic Humidity Control
 - Auto-Off Timer
 - Adjusting the Seasonal Allergy Setting

MAINTENANCE

- 20 FILTER CHANGE INDICATOR**
- 21 AIR FILTER MAINTENANCE**
 - Air Filter Care Overview
 - Cleaning the Air Filters
 - Replacing the Air Filters
- 25 HUMIDIFIER MAINTENANCE**
 - Cleaning the Humidifier Components
- 27 ADDITIONAL MAINTENANCE**
 - Cleaning the Exterior
 - Cleaning the Air Quality Sensor

TECHNICAL INFO

- 29 TROUBLESHOOTING**
- 31 PRODUCT SPECIFICATIONS**
- 32 WARRANTY**
- 33 CONTACT BRONDELL**

TRANSLATIONS

- 34 SPANISH VERSION**
- 68 FRENCH (CANADIAN) VERSION**

SAFETY INFORMATION (IMPORTANT SAFEGUARDS)

Be careful to keep this safety information. Please read this information to prevent property loss and ensure safety.

READ ALL INSTRUCTIONS BEFORE USING

⚠ DANGER: If not observed, serious injury or even death may occur as a result.

- Do not use a damaged power plug or plug into a loose electric outlet.
- Please connect the power plug to a grounded electrical outlet rated for 120 V ~ 60 Hz.
- Do not move the product by pulling on the power cord.
- Do not handle the product or power plug with wet hands.
- Do not forcefully bend the power cord or place heavy objects on it to prevent it from being damaged or deformed.
- Do not connect and pull out the power plug or cord repeatedly.
- If the electric outlet is wet, carefully unplug the product and let the electric outlet dry completely before subsequent use.
- Unplug the product before cleaning, repairing, inspecting, or replacing parts.
- Remove any dust or water from the power plug prior to plugging in.
- Do not plug the product into an electrical outlet or power strip that is being used by too many other products. Use an electrical outlet adequate for the wattage of the product.
- Unplug the system if it is not going to be used for a long time.
- If the power cord is damaged – do not operate the product and do not attempt to repair, modify, or replace the cord yourself. Contact the Brondell Service Center toll free at 888-542-3355 or email us through our website.
- If the product produces a strange noise, a burning smell, or emits smoke, unplug it immediately from the electrical outlet and contact Brondell. Failure to do so may result in electric shock or fire.
- Do not insert any wires or sharp objects into the air sensor or any product gaps. This may result in electric shock, fire, or product damage.

SAVE THESE INSTRUCTIONS

SAFETY INFORMATION (cont.) (IMPORTANT SAFEGUARDS)

⚠ DANGER: If not observed, serious injury or even death may occur as a result.

- Do not place an electronic or gas heater near the product or place near heating vent. This may result in fire or product deformation. Do not place any containers filled with water or other liquids, food, metallic objects, or any flammable material on top of the product. If foreign material enters the product, this may result in electric shock or fire.
- Do not use the product in locations exposed to excessive moisture or rain and do not splash water onto the product. Never place the product in or near water.
- Do not use the product in areas where flammable gases or combustible materials are used or stored.
- Do not spray any flammable materials such as insecticides or air fragrances near or into the air inlet.
- Do not disassemble, repair, or modify the product yourself. If repair is needed please contact the Brondell Service Center toll free at 888-542-3355 or email us through our website.
- Clean the exterior with a damp cloth. Do not clean the product using benzene, thinner, or abrasives.
- Do not use the air cleaner in a factory or industrial setting where machine oil may be present in the air.
- Do not drink or ingest any of the water or material from the Water Tray.
- Avoid external impacts to the water tank. A strong impact may damage the water tank.
- Empty the water tray and the water tank before moving the product.

SAVE THESE INSTRUCTIONS

SAFETY INFORMATION (cont.)

(IMPORTANT SAFEGUARDS)

⚠ WARNING: To reduce the risk of fire, electric shock or injury, read and understand this user guide before operating this appliance.

- To reduce the risk of fire, electric shock or injury, read and understand this user guide before operating this appliance.
- Do not insert fingers or foreign objects into the air quality sensor, air inlet or air outlet.
- Do not let children play with the product or climb on it. Children should be supervised to ensure that they do not play with the appliance.
- When removing the front cover, exercise caution that no clothing or body parts become stuck in the top vent of the product.
- This appliance can be used by children, age 8 years and up, and persons with reduced physical or mental capabilities if they have been given supervision or instruction concerning use of the appliance in a safe way and understand the hazards involved.
- Cleaning and user maintenance shall not be performed by children without supervision.
- Do not run cord under carpeting. Do not cover cord with throw rugs, runners, or similar coverings. Do not route cord under furniture or appliances. Arrange cord away from traffic area and where it will not be tripped over.
- Lack of proper cleaning and maintenance may result in fire, electric shock, or injury.
- Unplug or disconnect the appliance from the power supply before servicing.
- This appliance has a polarized plug (one blade is wider than the other). To reduce the risk of electric shock, this plug is intended to fit in a polarized outlet only one way. If the plug does not fit fully in the outlet, reverse the plug. If it still does not fit, contact a qualified electrician. Do not attempt to defeat this safety feature.

SAVE THESE INSTRUCTIONS

SAFETY INFORMATION (cont.) (IMPORTANT SAFEGUARDS)



CAUTION: If not observed, minor physical injury or property damage may occur as a result.

- Do not install the product on a sloped or uneven surface.
- Do not apply force or impact to the product.
- Install the product so that no obstacles block the circulation of air around the product.
- Install the air cleaner away from strong artificial lighting or direct sunlight. Do not install the air cleaner in a location exposed to direct sunlight.
- Replace the filters according to the filter replacement cycles.
- Clean the Mesh Pre-Filter with water regularly and dry it completely before reinstallation or use.
- Drain all the water from the product before moving it. Move the unit by using the handle only.

SAVE THESE INSTRUCTIONS

PRODUCT FEATURES

MAIN FEATURES

Dual True HEPA Air Filtration

Both of the Revive's True HEPA filters capture 99.97% of particles 0.3 μ and larger. The filter system has been optimized to quickly remove pollutants from the air.

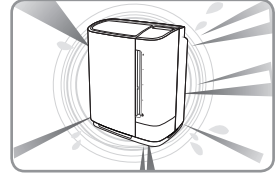

Efficient Double Suction System

The Revive utilizes a dual-filter system, with filters in the front and in the rear. With two fans and two air inlets, the Revive cleans the air quickly and efficiently.

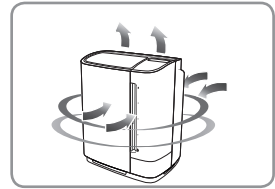

Auto-Adjusting Humidifier

Both a Humidifier Filter and a Humidity Sensor work together to control the amount of moisture released based on the room's temperature and humidity level.

The Revive also features Evaporative Humidification. See page 7 for more details.

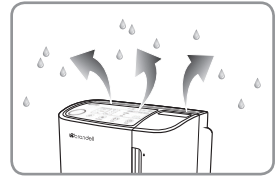

Four Operating Modes

In **Auto Mode** and **Eco Mode**, the air flow speed is automatically controlled based on the air quality in the room.

In **Allergen Mode**, the fan speed automatically goes to maximum, quickly removing pollutants in the room.

In **Fan Speed Mode**, or **Manual Mode**, the fan speed is set to your liking, regardless of the air quality in the room.

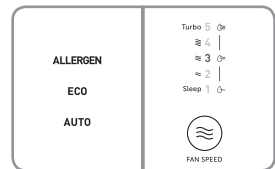

Air Quality Indicator

The Air Quality Indicator is a light that changes color in real time to indicate the air quality of the room, as measured by the Air Quality Sensor.

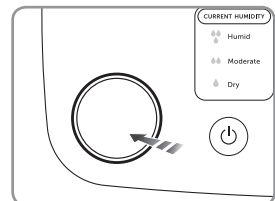

EVAPORATIVE HUMIDIFICATION

Humidification Method

The humidifying method used in the Revive is the Evaporative Humidification method. This method uses three parts: water tank, water tray and wick filter. The water tank supplies water to the water tray as the wick filter absorbs water. Air is drawn into the Revive and passes through the wick filter humidifying the air and expelling it back into the room.

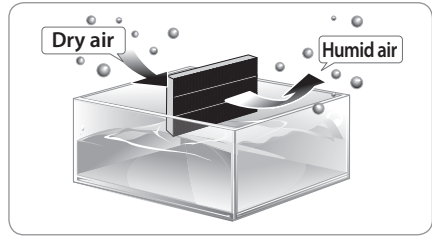

The expelled air temperature may feel cooler than the current room temperature. This is due to the air picking up moisture through the wick filter and losing heat. Depending on the room size this may have a cooling effect on the room's temperature.

Be aware that the humidifying effect on the room may be affected by the surrounding humidity or temperature. If the humidity is high or the temperature is low, the amount of moisture supplied by the humidifier may be low.

Evaporative Method Advantages

With the Evaporative Humidification Method, the water particles used to humidify the room's atmosphere are small and light-weight. The smaller particle size can travel through the air more easily and efficiently, providing an even humidity throughout the room instead of over-saturating the immediately-surrounding area.

Evaporative Humidification is self-regulating, as the room's atmosphere determines how much water evaporates from the humidifier into the air.

Coverage

The Revive's Humidifying feature is designed for optimum performance for a room of 350 square feet. If the Revive is used in a larger room, the humidifier may be less effective. To humidify a larger space set the fan speed to 3 in Humidifying Air Purifier Mode.

PRODUCT COMPONENTS

FRONT VIEW

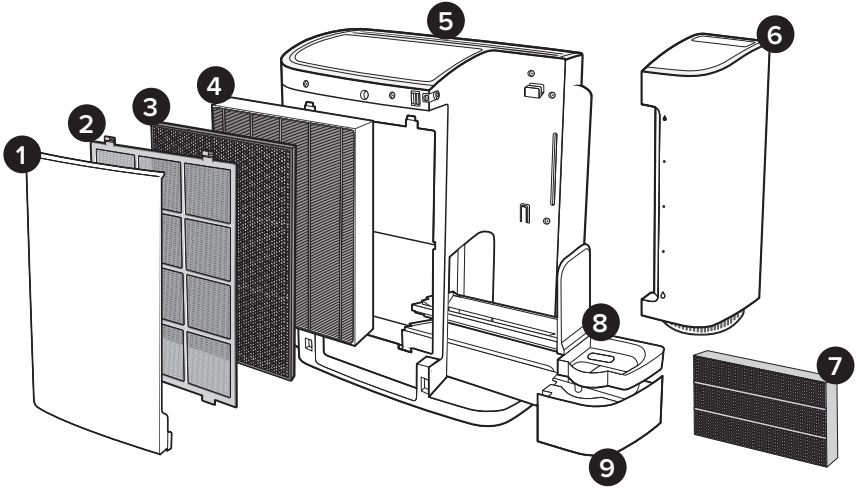

- | | |
|-------------------------|---------------------------|
| 1. Front Cover | 6. Water Tank |
| 2. Mesh Pre-Filter | 7. Humidifier Filter |
| 3. Active Carbon Filter | 8. Humidifier Filter Tray |
| 4. True HEPA Filter | 9. Water Tray |
| 5. Control Panel | |

TOP VIEW

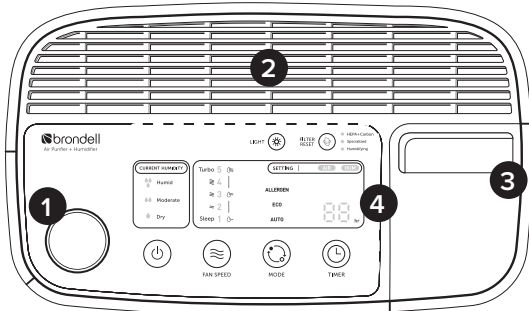

1. Air Quality Indicator
2. Air Outlet Vents
3. Water Tank Handle
4. Control Panel
(see pages 12-13 for more details)

REAR VIEW

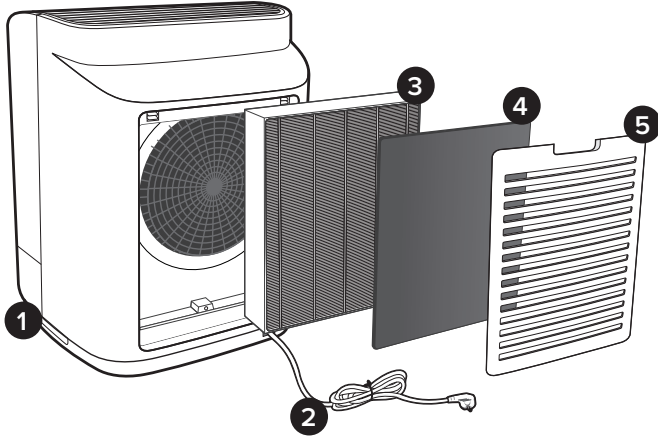

- 1. Handle
- 2. Power Cord
- 3. True HEPA Filter

- 4. Specialized Filter
- 5. Rear Cover

PRODUCT COMPONENTS (cont.)

AIR FILTERS

FRONT

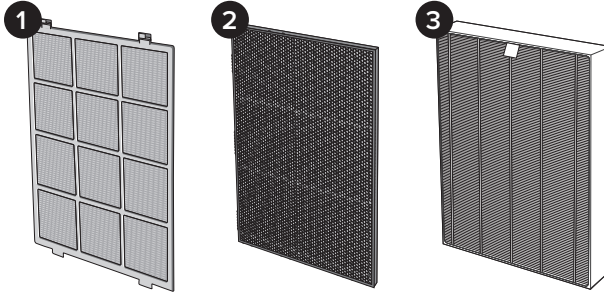

1. Mesh Pre-Filter

The Mesh Pre-Filter removes dust, mold, human hair, pet hair, and other large particles.

2. Active Carbon Filter

This filter contains granulated carbon, which traps and removes odors, harmful gases, and VOCs.

3. True HEPA Filter

Our True HEPA Filter removes 99.97% of particles 0.3 microns and larger, like dust, cigarette smoke, and pollen. It also reduces airborne bacteria and mold spores.

REAR

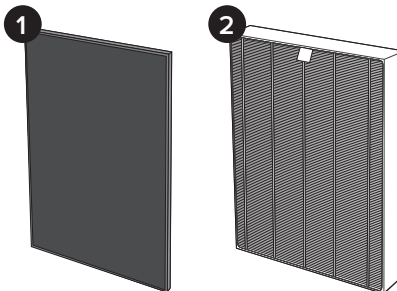

1. Specialized Filter

The Revive comes with an Off-Gassing Reduction filter. Using a proprietary catalyst, this filter effectively removes invisible substances like formaldehyde and VOCs (volatile organic compounds that include benzene and toluene) that contribute to “Sick House Syndrome” and can cause health and respiratory issues. Other Specialized Filters can be purchased separately.

2. True HEPA Filter

This filter is exactly the same as the HEPA filter in the front of the Revive in order to give you twice the filtration power.

HUMIDIFIER COMPONENTS

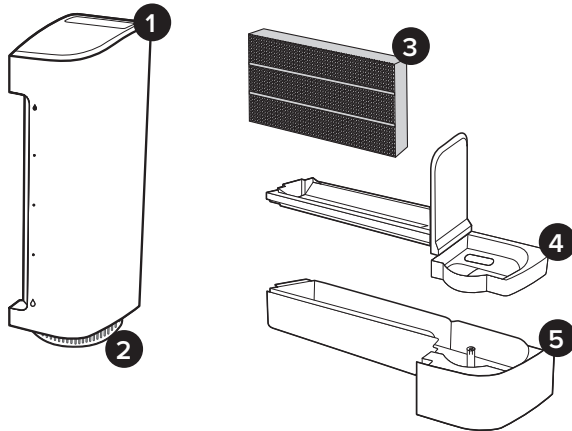

1. Water Tank

Stores 3.5 Liters of water and supplies water to the Water Tray.

2. Water Tank Cap

Secures water inside the Water Tank.

3. Humidifier Filter

The Humidifier Filter absorbs water. As the purified air from the air outlet passes through the Humidifier Filter, naturally-humidified air is released.

4. Humidifier Filter Tray

Holds the Humidifier Filter in place. This tray sits on top of the Water Tray.

5. Water Tray

Supplies an appropriate amount of water from the water tank to the Humidifier Filter.

CONTROL PANEL

BUTTONS

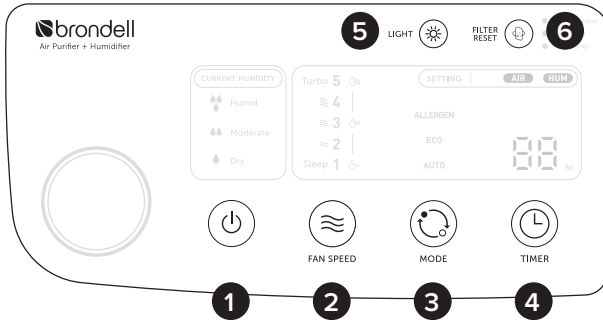

1. Power Button

Powers the Revive on and off. To turn off the power, press and hold the power button for approximately one second.



2. Fan Speed Button

Use it to select the desired fan speed. When you touch the button, the fan speed indicator changes in ascending order from 1 to 5. 1 is the lowest fan speed, and 5 is the highest.



3. Mode Button

This button toggles between the three “automatic” Operating Modes: Auto, Eco, and Allergen. See pages 16–17 for more detail on the individual operating modes.



4. Timer Button

This activates the Auto-Off Timer. Pressing this button increases the duration of the timer from 1 to 12 hours, in one-hour increments (indicated by #7 on the diagram on page 13). Once the timer has expired, the Revive will power off.

To cancel the auto-off timer, press and hold the Timer Button for two seconds.



5. Light On/Off Button

All displays except Air Purification indicator (AIR) and Humidifying indicator (HUM) are turned off. These are indicated by #6 on the diagram on page 13.



6. Filter Reset Button

Press this button to reset the Filter Change Timer after you have replaced filters in the Revive (see page 20 for more details).

INDICATORS

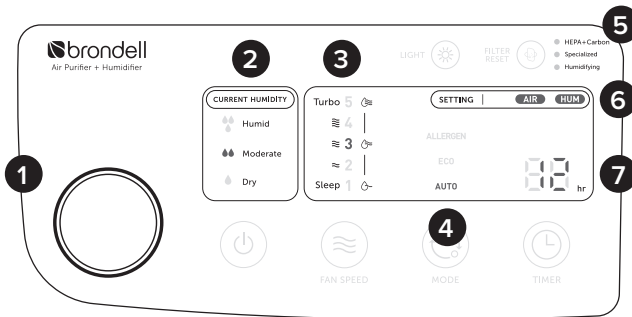

1. Air Quality Indicator

Indicates the air quality in the room with three colors:
Blue = Good air. Violet = Fair air. Red = Poor air.

2. Current Humidity Indicator

Indicates the humidity level in the room. See pages 17–18 for more details.

3. Fan Speed Indicator

This shows the current fan speed. The indicator changes in ascending order from 1–5. 1 is the lowest fan speed, and 5 is the highest.

4. Mode Indicator

This shows which of the three “automatic” Operating Mode is currently active: Auto, Eco, or Allergen. See pages 16–17 for more detail on the individual operating modes.

5. Filter Change Indicator

This shows which of the filters needs changing.

6. Air Purification / Humidifying Indicators

When the Water Tank has water in it, both the “AIR” and “HUM” symbols are displayed. This indicates that the Revive is cleaning and humidifying the air. When the Water Tank is empty, only the “AIR” symbol will be illuminated, meaning the Revive is not humidifying the air.

7. Timer Indicator

This displays the amount of time set for the Auto-Off Timer. The duration of the timer changes from 1 to 12 hours, in one-hour increments.

PREPARING FOR FIRST USE

INSTALLING THE FILTERS



Be sure to remove the plastic wrapping from the filters in the front and back of the Revive before turning it on.

This product is for indoor use only.

When the unit is not in use, unplug it from the electrical outlet.

1. Remove the Front Cover by pulling the top of the cover towards you. Lift up to disengage the bottom hinges.
2. Remove the Mesh Pre-Filter by pressing down on the two tabs at the top of the filter, then pull the filter out of the machine. Remove the other two filters.
3. Remove the plastic wrapping from the Active Carbon and True HEPA filters.
4. Put the filters back into the machine in the following order, ensuring that the pull-tabs on the True HEPA and Active Carbon Filters face forward:
 - a. True HEPA Filter (this goes in first)
 - b. Active Carbon Filter
 - c. Mesh Pre-Filter
5. Put the Front Cover on the Revive. Be sure it is seated correctly, as the unit will not power on if the Front Cover is not secure.
6. Remove the Back Cover by pulling down on the indentation at the top and lifting it away from the body of the machine.
7. Remove the Specialized and True HEPA Filters from the machine and remove the plastic wrapping from both filters.
8. Put the filters back into the machine in the following order, ensuring that the pull-tabs on the True HEPA and Specialized Filters face forward:
 - a. True HEPA Filter (this goes in first)
 - b. Specialized Filter
9. Put the Back Cover on the Revive and ensure it is securely in place.

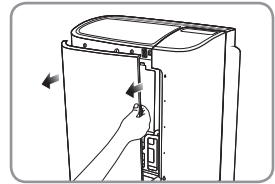

Step 1

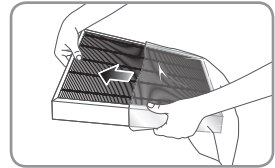

Step 3

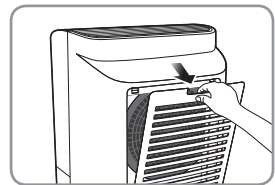

Step 6

PREPARING THE HUMIDIFIER



If you do not want to use the Humidifier function, do not perform the steps below. Instead, remove the Humidifier Filter and store it in a cool, dry location.

If the Water Tank or Water Tray are not properly seated, the Revive will not power on.

1. Remove the Water Tank by pulling the handle up. Then move the tank away from the machine.
2. Lift the Water Tray slightly and slide it out of the machine.
3. Remove the Humidifier Filter from the Water Tray, remove the plastic wrapping from the filter, and place back into the Water Tray.
4. Slide the Water Tray back into the machine, ensuring that it is seated correctly.
5. Fill the Water Tank:
 - a. Flip the tank over to access the Water Tank Cap.
 - b. Remove the Water Tank Cap by turning it counter-clockwise.
 - c. Fill the Tank with cold water to the specified fill line.
 - d. Screw the Water Tank Cap back onto the Tank by turning it clockwise until tight.
6. Put the Water Tank back onto the machine, ensuring that it is seated correctly.

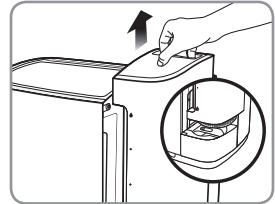

Step 1

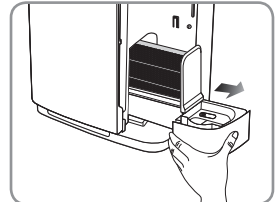

Step 2

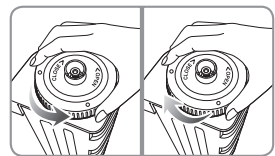

Step 5

If the Water Tank is not properly tightened and seated, leaking and product malfunction may occur.

Do not fill the Water Tank with water over 104°F.

Do not add disinfectants, essential oils, fragrances, or any other additives to the water in the Water Tank.

NOTE: The amount of moisture supplied by the Humidifier Filter may decrease when there is scale build-up. Check the Humidifier Filter periodically and clean it when necessary (refer to Step 3 on page 26 for instructions).

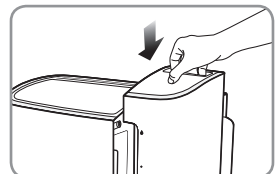

Step 6

PRODUCT OPERATION

POWERING THE REVIVE ON

1. To power the Revive on, press the Power Button. The Operating Mode and Fan Speed setting will automatically resume with the settings from when the unit was previously powered on.

NOTE: If the Revive was previously in Auto Mode, it will begin sensing the air quality in the room when powered on. During this time, the Fan Speed will be set to 2, and the Air Quality Indicator will show Violet. After 10 seconds, the Revive will adjust the fan speed and Air Quality Indicator according to the air quality in the room.

2. Also, when the Revive is powered on, the Humidity Indicator turns on after a period of five seconds, reflecting the humidity level in the room.

Dry = 40% humidity or less

Moderate = 40–60% humidity

Humid = 60% humidity or more

NOTE: During the five-second waiting period, the Humidity Indicator lights will flash in sequence from Dry to Humid

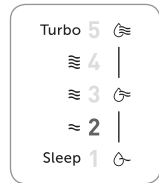

Step 1

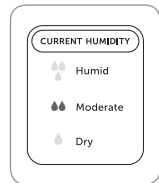

Step 2

OPERATING MODES

1. Once the Revive has powered on and performed the air quality and humidity auto-sensing, you are free to choose between the four different Operating Modes:

Auto Mode

During Auto Mode, the Revive checks the air quality in the room every 10 seconds and adjusts the Fan Speed accordingly. The Air Quality Indicator will also change depending on the air quality:

Blue = Good air. Violet = Fair air. Red = Poor air.

Eco Mode

In Eco Mode, the Revive will run on Fan Speed 2 for ten minutes, and then power the fan off for thirty minutes. This cycle will alternate until you change to a new Operating Mode.



OPERATING MODES (cont.)

Allergen Mode

Allergen Mode is a three-step process by which the Revive's fan speed is maximized and then throttled-down over a period of time in order to purify a large amount of air in the least amount of time. Below are the steps and their durations:

- Step 1: Ten minutes at Fan Speed 5
- Step 2: Five minutes at Fan Speed 4
- Step 3: Five minutes at Fan Speed 3

The timing and fan speed are pre-determined and do not change with a change in air quality, unless you intervene to change to a new Operating Mode.

After these steps have concluded, the Revive will switch to Auto Mode.

Fan Speed Mode

This can also be referred to as Manual Mode. Select the Fan Speed at which you want the Revive to operate, and the fan speed will stay constant, regardless of changes to the air quality in the room.

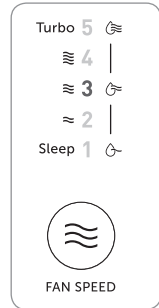

AUTOMATIC HUMIDITY CONTROL

1. In Auto Mode and Eco Mode, the fan speed will change according to a combination of humidity and air quality sensor readings. These combinations, and their resulting fan speeds, are outlined below.

NOTE: Automatic Humidity Control will only work if the Water Tank contains water and is seated correctly.

HUMIDITY	AIR QUALITY & INDICATOR COLOR	FAN SPEED
Humid or Moderate	Level 1 – Blue	2
	Level 2 – Violet	3
	Level 3 – Red	4
Dry	Level 1 – Blue	3
	Level 2 or 3 – Violet or Red	4

PRODUCT OPERATION (cont.)

AUTOMATIC HUMIDITY CONTROL (cont.)

2. When the Revive is actively evaluating the air quality and humidity levels, the “AIR” and “HUM” indicators will be illuminated. This is also an indication that the Water Tank has a sufficient amount of water for the humidifier to function.

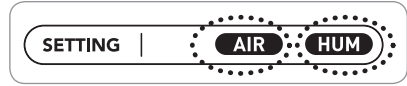

Step 2

3. When the Water Tank is empty, or no longer contains a sufficient amount of water, the Revive will stop Humidifying. In this instance, only the “AIR” indicator will be illuminated.

To ensure that the Revive always has the humidifier active, ensure that the Water Tank contains sufficient water.



Step 3

AUTO-OFF TIMER

1. You can set the Revive to power off entirely after a set amount of time. Press the Timer Button until the desired duration appears. The Revive will power off when the timer expires.
2. The Auto-Off Timer can be set for 1–12 hours, in one-hour increments
3. To cancel the Auto-Off Timer, press and hold the Timer Button for two seconds.



Step 1

ADJUSTING THE SEASONAL ALLERGY SETTING

During “allergy season”, or periods when pollen and other allergens are more prevalent in your area, you may opt to increase the sensitivity of the Air Quality Sensor so that the Revive increases the fan speed more frequently in Auto or Eco Mode.

Conversely, if you live in an area where allergens are not common, you can decrease the sensitivity of the air quality sensor so that the Revive stays at a low fan speed more often in Auto or Eco Mode.

NOTE: There are three levels for the Seasonal Allergy Setting:

Level 1: Low Sensitivity (for low allergen levels)

Level 2: Standard Sensitivity

Level 3: High Sensitivity (for high allergen levels)

The default Seasonal Allergy Setting is Level 2. To adjust the Revive's Seasonal Allergy Setting, follow the steps below.

1. Touch and hold both the Fan Speed Button and the Mode Button for two seconds to enter the Seasonal Allergy Setting Mode. The fan speed numbers will blink while you are making your selection.
2. Press the Fan Speed button to adjust the Seasonal Allergy Setting. Each of the first three fan speed settings corresponds to the sensitivity setting in Seasonal Allergy Setting Mode.

FAN SPEED	SENSITIVITY LEVEL
1	Level 1: Low
2	Level 2: Standard
3	Level 3: High

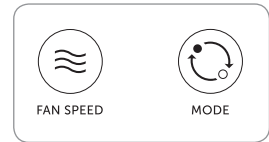

Step 1

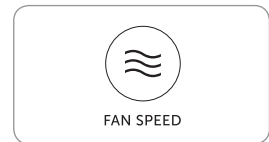

Step 2

3. If no button is pressed for 10 seconds after entering into Seasonal Allergy Setting Mode, the previous sensitivity level is automatically selected, and the Revive will return to the last Operating Mode it was in.

FILTER CHANGE INDICATOR

FILTER CHANGE INDICATOR

When the filter replacement cycle has been reached for one or more of the filters, the Filter Change Indicator becomes illuminated. A light will come on next to the name of the filter (or filters) that needs to be replaced.

1. Follow the steps on page 24 to replace the affected filter(s).
2. Once that process is complete, press the Filter Reset Button for two seconds to reset the Filter Change Indicator.
3. Forced reset of the Filter Change Indicator:

If you change any one of the filters before the corresponding Filter Change Indicator has illuminated, you will need to force the timer for that filter to reset.

- a. Press and hold the Filter Reset Button for two seconds. The “HEPA+Carbon” indicator will begin to blink.
- b. Once the “HEPA+Carbon” indicator is blinking, press the Filter Reset Button until the filter (or filters) you replaced are blinking.
- c. Press and hold the Filter Reset Button for two seconds to reset the timer. If you replaced multiple filters, repeat this process until all the filter timers have been reset for the filters you replaced.

NOTE: If there is no activity for ten seconds after completing step a, this reset mode will be cancelled and the “HEPA+Carbon” indicator will stop blinking.

● HEPA+Carbon

● Specialized

● Humidifying

**FILTER
RESET**



AIR FILTER MAINTENANCE

AIR FILTER CARE OVERVIEW

Below is a recommended cleaning and replacement schedule for all of the Revive's air filters. This is only a guideline, however, as time of use and prevailing air quality will have the greatest effect on how often the filters need to be cleaned or replaced.

In addition, it is highly recommended that you also adhere to the cleaning schedule for the Humidifying Components on page 25.

LOCATION	FILTER	METHOD	CLEANING CYCLE
Front	Mesh Pre-Filter	Clean	Every 2-4 weeks
Front	Active Carbon Filter	Replace	Every 12 months
Front	True HEPA Filter	Replace	Every 12 months
Rear	True HEPA Filter	Replace	Every 12 months
Rear	Specialized Filter	Clean	Every 2-4 weeks
		Replace	Every 4 months



Always unplug the power cord before cleaning or replacing the filters.

AIR FILTER MAINTENANCE (cont.)

CLEANING THE AIR FILTERS

The Revive uses several filters. Some of them should be cleaned on a regular basis, and others must be replaced. Please see page 21 for the complete air filter cleaning and replacement schedule.

Below is a recommended cleaning schedule for the Mesh Pre-Filter and the Specialized Filter. This is only a guideline, however, as time of use and prevailing air quality will have the greatest effect on how often the filters need to be cleaned or replaced.

LOCATION	FILTER	METHOD	CLEANING CYCLE
Front	Mesh Pre-Filter	Clean	Every 2-4 weeks
Rear	Specialized Filter	Clean	Every 2-4 weeks
		Replace	Every 4 months



Always unplug the power cord before cleaning the filter(s).

The Mesh Pre-Filter is reusable and does not need to be replaced. If the Mesh Pre-Filter is not kept clean, the Revive's performance may deteriorate.

The Specialized Filter can be cleaned as well, but is also scheduled to be replaced every four months.

The Active Carbon and True HEPA filters are not reusable. Do not attempt to clean them with water.

1. Cleaning the Mesh Pre-Filter

- a. Remove the Front Cover by pulling the top of the cover towards you. Lift up to disengage the bottom hinges.
- b. Push down on the tabs at the top of the Mesh Pre-Filter and pull the filter towards you to remove it.
- c. Clean the Mesh Pre-Filter with a vacuum cleaner first. If the mesh is still dirty, wash with warm water and air dry before you put it back into the Revive.
- d. Once it is clean, snap the Mesh Pre-Filter back into place and put the Front Cover back onto the Revive. Ensure that it is securely in place. If the Front Cover is not seated properly, the Revive will not power on.

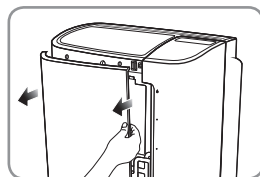

Step 1a

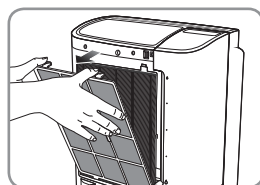

Step 1b

CLEANING THE AIR FILTERS (cont.)

2. Cleaning the Specialized Filter

- a. Remove the Back Cover by pulling down on the indentation at the top and lifting it away from the body of the machine.
- b. Pull out the Specialized Filter.
- c. Clean the Specialized Filter with a vacuum cleaner first. If the filter is still dirty, replace the filter. Do not clean the Specialized Filter with water.
- d. Once it is clean, put the Specialized Filter back into place and put the Back Cover onto the Revive. Ensure that it is securely in place.

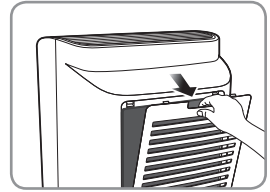

Step 2a



Step 2b

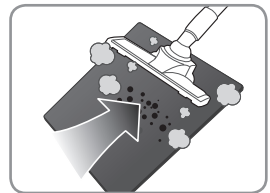

Step 2c

AIR FILTER MAINTENANCE (cont.)

REPLACING THE AIR FILTERS

1. Remove the Front Cover by pulling the top of the cover towards you and then lifting up to disengage the bottom hinges.
2. Remove the Mesh Pre-Filter by pressing down on the two tabs at the top of the filter and pulling the filter out of the machine. Remove the used Active Carbon and True HEPA filters.
3. Remove the plastic wrapping from the new Active Carbon and True HEPA filters.
4. Put the filters back into the machine in the following order, ensuring that the pull-tabs on the True HEPA and Active Carbon Filters face towards you:
 - a. True HEPA Filter (this goes in first)
 - b. Active Carbon Filter
 - c. Mesh Pre-Filter
5. Put the Front Cover back on the Revive. Be sure it is seated correctly, as the unit will not power on if the Front Cover is not secure.
6. Remove the Back Cover by pulling down on the indentation at the top and lifting it away from the body of the machine.
7. Remove the used Specialized and True HEPA Filters from the back of the Revive and remove the plastic wrapping from the new filters.
8. Put the filters back into the machine in the following order, ensuring that the pull-tabs on the True HEPA and Specialized Filters face towards you:
 - a. True HEPA Filter (this goes in first)
 - b. Specialized Filter
9. Put the Back Cover back on the Revive and ensure it is securely in place.
10. Follow the instructions in Step 3 on page 26 to clean the Humidifier Filter.

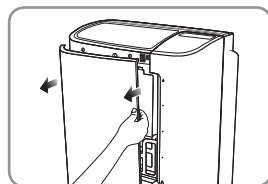

Step 1

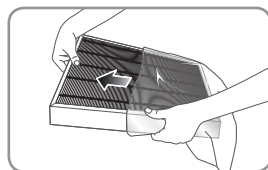

Step 3

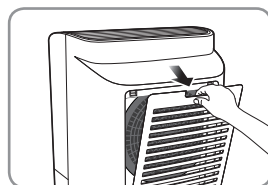

Step 6

HUMIDIFIER MAINTENANCE

CLEANING THE HUMIDIFIER COMPONENTS

Below is a recommended cleaning schedule for the Revive's Humidifier Components. The frequency is designed to avoid the build-up of scale, mold and/or mildew in the Water Tank, the Water Tray, and the Humidifier Filter. The frequency of scale build-up depends on the hardness of the water put into the system. For maximum effectiveness, use a Brondell H2O+ Water Filtration unit in combination with the Revive.

LOCATION	FILTER/PART	METHOD	CLEANING CYCLE
Right Side	Water Tank	Clean	Every 2 weeks
Right Side	Water Tray	Clean	Every 2 weeks
Right Side (Water Tray)	Humidifier Filter	Clean	Every 2 weeks
		Replace	Every 4 months



Always unplug the power cord before cleaning the Humidifier Components.
Do not use bleach, chlorine, abrasives, or soaps/detergents that contain solvents.

1. Cleaning the Water Tank

- Remove the Water Tank by pulling the handle up. Then move the tank away from the machine. Remove the Water Tank Cap by turning it counter-clockwise.
- Fill the Water Tank one-third of the way and add a small amount of neutral detergent. Replace the Water Tank Cap and shake the Water Tank vigorously to wash the inside of the tank. Do not use abrasives.
- Remove the Water Tank Cap and rinse the inside of the Water Tank thoroughly, ensuring that there is no leftover soap inside. While rinsing out the inside, wash down the exterior of the tank. Do not use abrasives.
- Dry off the exterior of the Water Tank completely. Fill the Water Tank with cold water and replace the Water Tank Cap. Reinstall the Water Tank, ensuring that it is seated correctly.

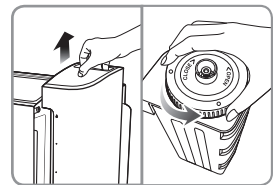

Step 1a

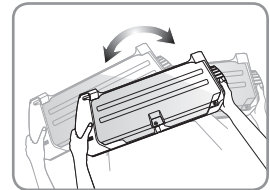

Step 1b

NOTE: If you do not want the Revive to humidify the air, do not fill the Water Tank before you re-install it.

HUMIDIFIER MAINTENANCE (cont.)

CLEANING THE HUMIDIFIER COMPONENTS (cont.)

2. Cleaning the Water Tray

- a. Remove the Water Tank and set it aside. If you also need to clean the tank, follow the steps on page 25.
- b. Remove the Humidifier Filter from the Water Tray and set it aside (see Step 3 below if you need to also clean the Humidifier Filter).
- c. Lift the Humidifier Filter Tray from the Water Tray, and clean them both with a soft cloth under running water. Use a neutral detergent. Do not use abrasives.
- d. Ensure that the Water Tray and Humidifier Filter Tray are completely dry before reassembling. Place the Humidifier Filter Tray back onto the Water Tray.

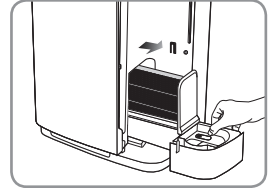

Step 2b

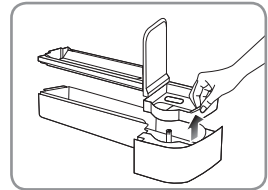

Step 2c

⚠ If the Humidifier Filter Tray is not properly seated, leaking and product malfunction may occur.

3. Cleaning the Humidifier Filter

- a. Fill a large bowl with lukewarm water. It will be used as a bath for Humidifier Filter.
- b. Remove the Humidifier Filter from the Water Tray and place it in the water bowl from the previous step.
- c. Leave the Humidifier Filter in the water bath for 20 minutes, and then gently wash it with a soft brush, cloth, or sponge.

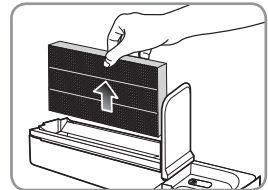

Step 3b

NOTE: If there is a white build-up of scale on the Humidifier Filter, run it under warm water while you wash it with the a soft brush or cloth.

- d. Place the Humidifier Filter Tray back onto the Water Tray. Ensure that the Water Tray and Humidifier Filter Tray are completely dry before reassembling.

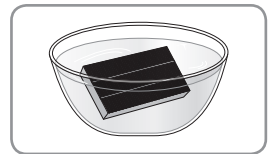

Step 3c

⚠ If proper cleanliness of the Humidifier Filter is not maintained, the Revive may start giving off an odor. Proper maintenance of all the Humidifying Components is vital to the Revive's performance and sanitation.

ADDITIONAL MAINTENANCE

CLEANING THE EXTERIOR

Below is a recommended cleaning schedule for the Revive's exterior and Air Quality Sensor. This is only a guideline, however, as time of use and prevailing air quality will have the greatest effect on how often these components need to be cleaned.

COMPONENT	CLEANING CYCLE
Back Cover	Every 4 weeks
Body Panels	Every 4 weeks
Air Outlet Vents	Every 8 weeks
Air Quality Sensor	Every 8 weeks

Always unplug the power cord before cleaning the Revive.
Do not use bleach, chlorine, abrasives, or soaps/detergents that contain solvents.
Do not spray water into or on the Revive to clean it.

1. Cleaning the Back Cover

- Remove the Back Cover by pulling down on the indentation at the top and lifting it away from the body of the machine.
- Clean off the Back Cover with a soft brush or cloth and put the Back Cover onto the Revive. You can also use a vacuum cleaner if desired.

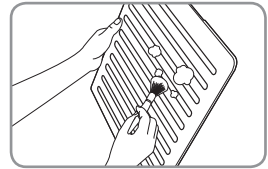

Step 1b

2. Cleaning the Body Panels

- Use a soft, dry cloth to sweep dust and loose particles off of the Revive's body.
- Use a damp cloth to remove additional dirt. Do not use abrasives.

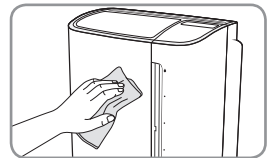

Step 2a

3. Cleaning the Air Outlet Vents

- Clean off the Air Outlet Vents with a soft brush or cloth. You can also use a vacuum cleaner if desired.

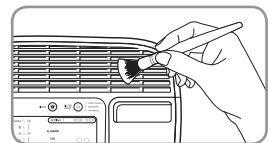

Step 3a

ADDITIONAL MAINTENANCE (cont.)

CLEANING THE EXTERIOR (cont.)

4. Cleaning the Air Quality Sensor

- As you are facing the unit, locate the Air Quality Sensor on the left side. Open the cover by pulling down on the indentation at the top and lowering it to a 90° angle. The cover is not removable, and will stay in place while opened.
- Clean the Air Quality Sensor Cover with a soft brush or cloth. You can also use a vacuum cleaner if desired.
- Using the diagram to the right as a guide, lightly moisten a cotton swab and clean the Lens (a), Air Inlet (b), and Air Outlet (c). Wipe off all moisture with a dry cotton swab.

NOTE: Without regular cleaning, the Air Quality Sensor's performance will deteriorate.

In areas with a higher concentration of pollutants, clean the Air Quality Sensor more often.

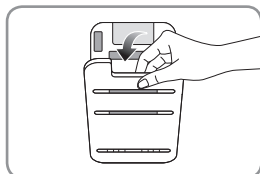

Step 4a

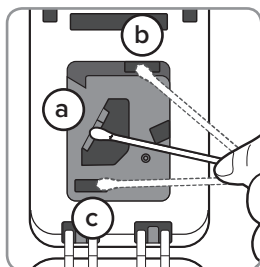

Step 4c

TROUBLESHOOTING

CONDITION	POSSIBLE CAUSE	POSSIBLE SOLUTION
No air is blowing.	Plastic packaging on filters was not removed.	Remove the plastic packaging and put the filters back in.
	The power cord is not plugged in or properly inserted into the electrical outlet.	Plug the power cord into an electric outlet rated for 120V.
	Power plug or cord is damaged.	Contact the Brondell Service Center at 888-542-3355.
	The Revive is not powered on.	Press the Power Button.

CONDITION	POSSIBLE CAUSE	POSSIBLE SOLUTION
1. Fan speed does not automatically adjust when in Auto Mode. 2. The color of the Air Quality Indicator never changes.	Manual Mode is selected. ¹	Press the Mode Button until "Auto" is illuminated.
	Air Quality Sensor is dirty. ^{1,2}	Follow the steps on page 28 to clean the Air Quality Sensor.
	Air Quality Sensor sensitivity is inadequate for the air quality in the room. ^{1,2}	Follow the steps on page 19 to set a different Seasonal Allergy Setting: <ul style="list-style-type: none"> • If the Air Quality indicator is Blue, use a higher sensitivity. • If the Air Quality Indicator is Purple or Red, use a lower sensitivity.
	Air Quality Sensor is broken or is malfunctioning. ^{1,2}	Contact the Brondell Service Center at 888-542-3355.

CONDITION	POSSIBLE CAUSE	POSSIBLE SOLUTION
Only the Air Purification (AIR) and Humidifying (HUM) indicators are illuminated.	The Light Off Button has been pressed.	Press the Light Off Button again to restore the control panel to full illumination.

TROUBLESHOOTING (cont.)

CONDITION	POSSIBLE CAUSE	POSSIBLE SOLUTION
Airflow has diminished, even at high fan speeds.	Plastic packaging on filters was not removed.	Remove the plastic packaging and put the filters back in.
	Blockage at Air Inlet or Air Outlet.	Contact the Brondell Service Center at 888-542-3355.
	Filters are due for replacement.	Replace with a new filter set.
	Clearance around air purifier is not adequate for air ventilation.	Ensure that there is clearance of 20 inches on each side and 4 inches behind the air purifier.
	Missing filters or filters were inserted in the wrong order.	Ensure the filters are placed in the correct order (see pages 8–9).
	Recommended room size has been exceeded.	Suggested coverage area is a medium-to-large room.

CONDITION	POSSIBLE CAUSE	POSSIBLE SOLUTION
The Revive runs only in Fan Speed 3 or 4 while humidifying is active.	The air quality in the room is poor, or the humidity level is low.	Put the Revive into Fan Speed Mode, or Manual Mode. You can also empty the Water Tank to stop the Revive from humidifying (see page 15).

CONDITION	POSSIBLE CAUSE	POSSIBLE SOLUTION
There is an odor emanating from the Revive.	The Humidifying Components have not been properly cleaned or maintained.	See pages 25–26 for instructions on proper care of the Humidifying Components.

CONDITION	POSSIBLE CAUSE	POSSIBLE SOLUTION
The Air Quality Indicator is blinking.	The Revive requires service.	Contact the Brondell Service Center at 888-542-3355.

PRODUCT SPECIFICATIONS

Model	Revive PR50-W, PR50-B
Rated power source	120 V ~ 60 Hz
Power consumption	65 W
CADR	225
Maximum recommended room size	350 sq. ft.
Maximum airflow volume*	251 cu. ft. / min
Water tank capacity	0.92 gal / 3.5 L
Maximum Humidifying capacity	350 ml/hr
Dimensions	15.6" x 12.5" x 19" 396 mm x 318mm x 482 mm
Weight	20 lbs. / 9.1 kg

* The Maximum Airflow Volume was measured without installing the Humidifier Filter.
All the technical details above are made by the internal tests and some of the testing values could be different depending on the testing condition



This air cleaner complies with the Federal Ozone Emissions Limit.
ARB CERTIFIED

WARRANTY

Brondell products are backed by some of the most comprehensive warranties in the industry. Brondell warrants that the O2+ air purifier shall be free from defects in material and workmanship under normal use and service.

Residential Warranty for O2+ Air Purifiers – 3 year limited warranty

100% Coverage of defects or malfunctions of all electronic parts and labor for the entire product excluding consumable filters for the first three years from original date of purchase.

Commercial Warranty for O2+ Air Purifiers – 1 year limited warranty

Warranty period 1 year from original purchase date for O2+ Air Purifiers. Warranties may not apply to products that are used for heavy commercial, hospital, or other high-use non-residential applications.

Exclusions and Limitations

1. BRONDELL warrants its products to be free from manufacturing defects under normal use and service. This warranty is extended only to the ORIGINAL PURCHASER.
2. BRONDELL's obligations under this warranty are limited to repairs or replacement, at BRONDELL's option, of products or parts found to be defective, provided that such products were properly installed and used in accordance with instructions. BRONDELL reserves the right to make such inspections as may be necessary in order to determine the cause of the defect. BRONDELL will not charge for labor or parts in connection with warranty repairs for the first full year from date of purchase on all products except those that may be subject to commercial use limitations.
3. BRONDELL is not responsible for the cost of removal, return (shipping) and/or reinstallation of products. This warranty does NOT apply to:
 - Damage or loss which occurs during shipment.
 - Damage or loss sustained through any natural or man-made causes beyond the control of BRONDELL, including but not limited to fire, earthquake, floods, etc.
 - Damage or loss resulting from sediments or foreign matter contained in a water system.
 - Damage or loss resulting from negligent or improper installation including installation of a unit in a harsh or hazardous environment.
 - Damage or loss resulting from removal, improper repair, modification of the product, or improper maintenance including damage caused by chlorine or chlorine related products
 - Damage or loss resulting from acts which are not the fault of Brondell or which the Product is not specified to tolerate.
4. This warranty gives you specific legal rights. You may have other rights which vary from state to state.

THIS WRITTEN WARRANTY IS THE ONLY WARRANTY MADE BY BRONDELL. REPAIR OR REPLACEMENT AS PROVIDED UNDER THIS WARRANTY SHALL BE THE EXCLUSIVE REMEDY AVAILABLE TO THE PURCHASER. BRONDELL SHALL NOT BE RESPONSIBLE FOR LOSS OF USE OF THE PRODUCT OR FOR OTHER INCIDENTAL, SPECIAL, FOR CONSEQUENTIAL DAMAGES OR EXPENSES INCURRED BY THE PURCHASER OR FOR LABOR OR OTHER COSTS DUE TO INSTALLATION OR REMOVAL OR COSTS OF REPAIRS BY OTHERS, OR FOR ANY OTHER EXPENSE NOT SPECIFICALLY STATED ABOVE. EXCEPT TO THE EXTENT PROHIBITED BY APPLICABLE LAW, ANY IMPLIED WARRANTIES, INCLUDING THAT OF MERCHANTABILITY, ARE EXPRESSLY LIMITED TO THE DURATION OF THIS WARRANTY. SOME STATES DO NOT ALLOW LIMITATIONS, SO THE ABOVE LIMITATION AND EXCLUSION MAY NOT APPLY TO YOU.

How to Obtain Service

To obtain repair service under this warranty, you must contact an authorized BRONDELL Service Center to obtain an RMA (Return Merchandise Authorization) number. Proof of purchase in the form of a copy of the original receipt must accompany the returned unit for the warranty to be valid. Take or ship the unit pre-paid to the closest Brondell authorized service center along with the RMA number and proof of purchase. *To obtain an RMA number, contact the BRONDELL Service Center at 1-888-542-3355.*



a healthy home experience

CONTACT:

Brondell, Inc.

PO Box 470085

San Francisco, CA 94147-0085

Phone: 1-888-542-3355

Email: support@brondell.com

Web: www.brondell.com

For questions, contact Brondell Customer Service: 1-888-542-3355

MANUFACTURED BY:

Brondell, Inc.

PO Box 470085

San Francisco, CA 94147-0085

REPLACEMENT FILTERS:

PRF-51 Standard Annual Replacement Filter Set

1 Active Carbon Filter

2 True HEPA Filters

PRF-52 Annual Replacement Humidity Filter Set

3 Humidity Filters

PRF-58 Annual Replacement Off-Gassing Reduction Filter Set

3 Off-Gassing Reduction Filters